

# YZ-4 SF

## SETTING SHEET Ver.01

### CIRCUIT EOS-Carpet starting setup

- INDOOR  OUTDOOR
- DIRT  ASTROTURF  CARPET  GRASS  WOOD
- WET  DRY  DUSTY  SMOOTH  BUMPY
- HARD PACKED  CLAY  BLUE GROOVE  \_\_\_\_\_
- LOW TRACTION  MED TRACTION  HIGH TRACTION

DRIVER Raoul Nebelung

DATE \_\_\_\_\_

## FRONT

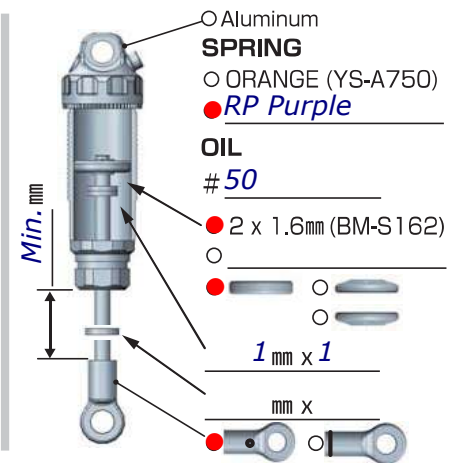
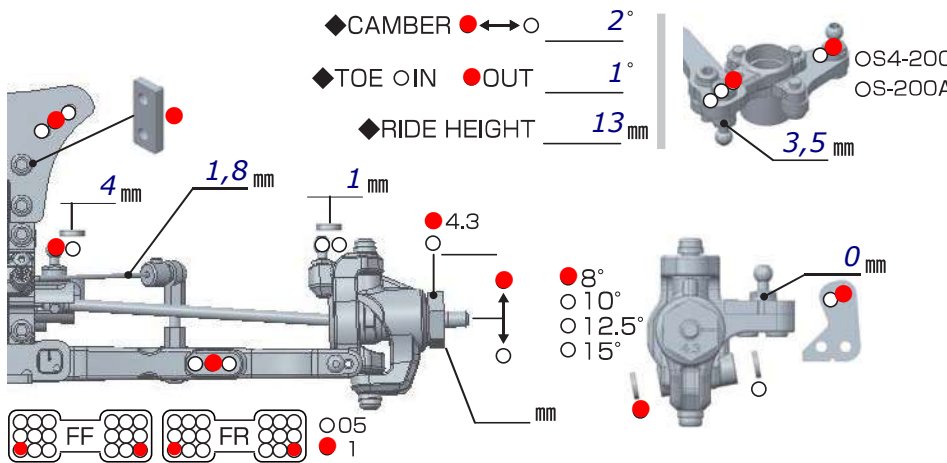

## REAR

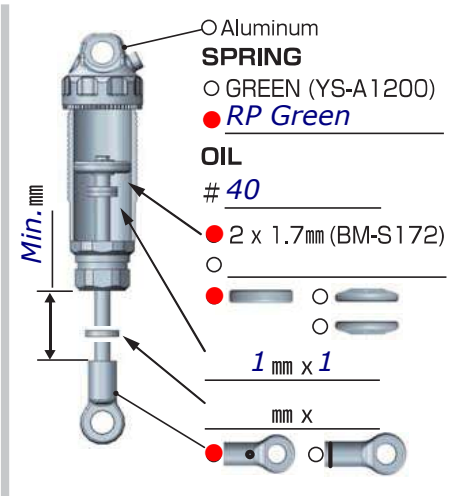
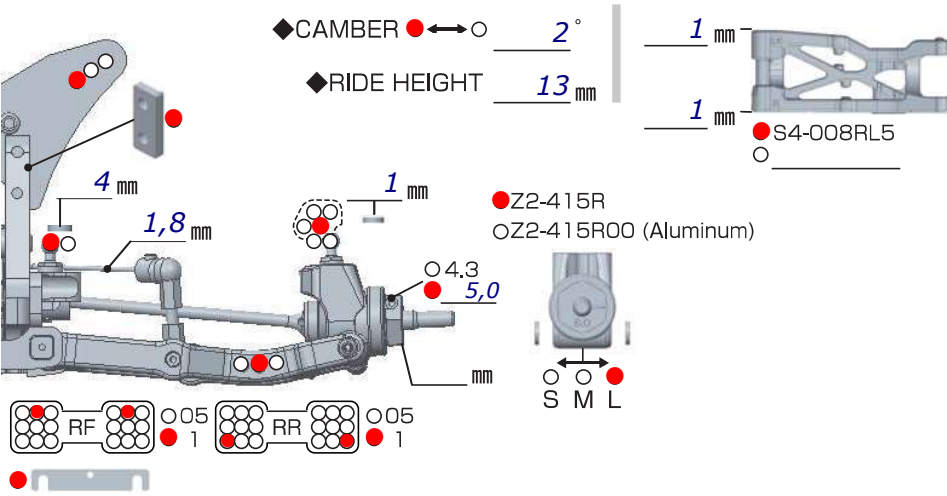

## DRIVE

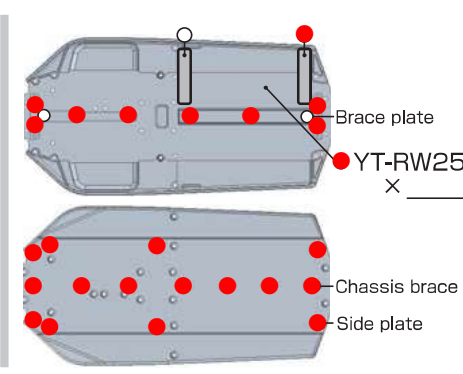
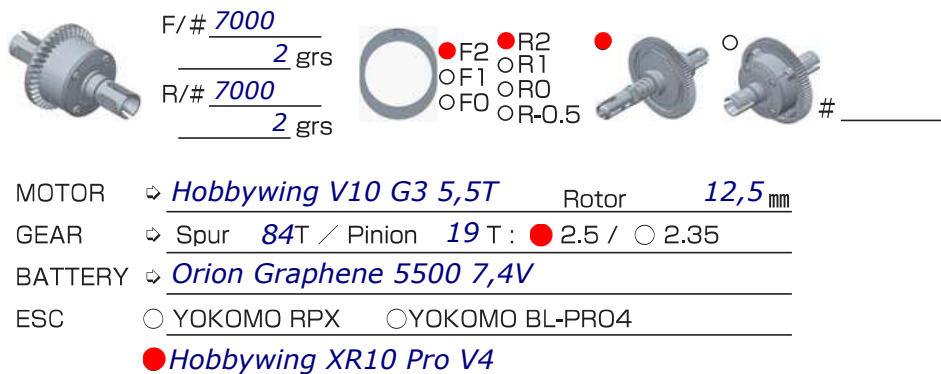

## TIRE

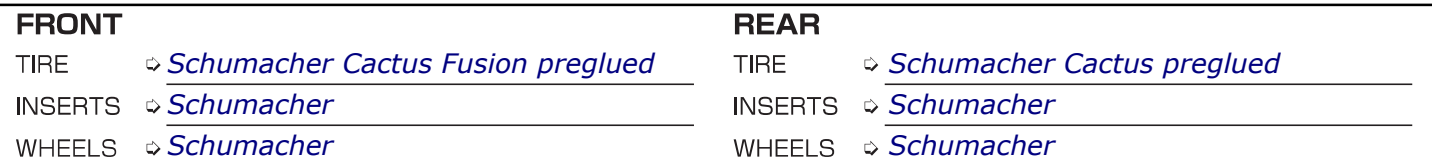

## OTHER

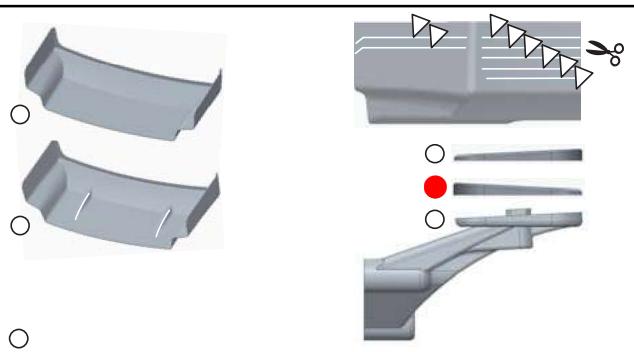

- RDRP Steeringrack
  - RDRP 27g weight behind motor
  - Loose Slipper
  - Rear tires cut one row in- and outside
  - Rear shocks spaced out 2MM at top
- COMMENT \_\_\_\_\_