



SETTING SHEET Ver.02

CIRCUIT

EOS Rd3

- INDOOR ○ OUTDOOR
- WET ○ DRY ○ DUSTY ○ OTHER
- LOW TRACTION ○ MED TRACTION ● HIGH TRACTION
- SMOOTH ○ BUMPY ○ BLUE GROOVE ○ ASTROTURF
- CARPET ○ WOOD

DRIVER Mark Rheinard

DATE 2016/01/30

FRONT

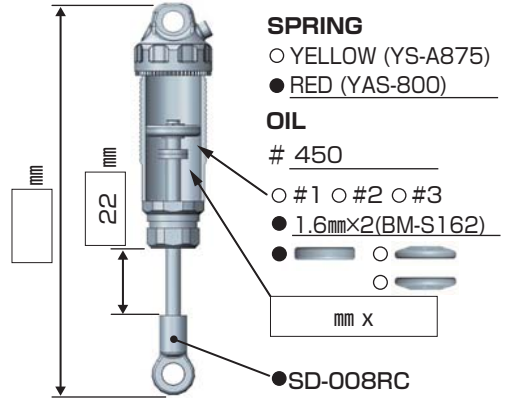
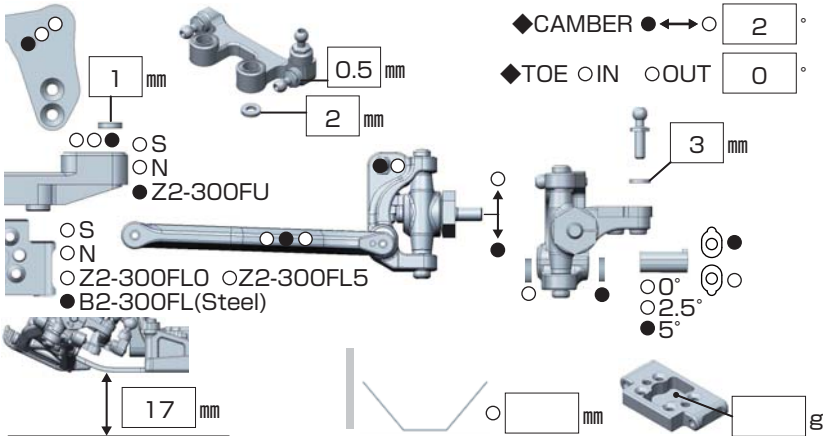

REAR

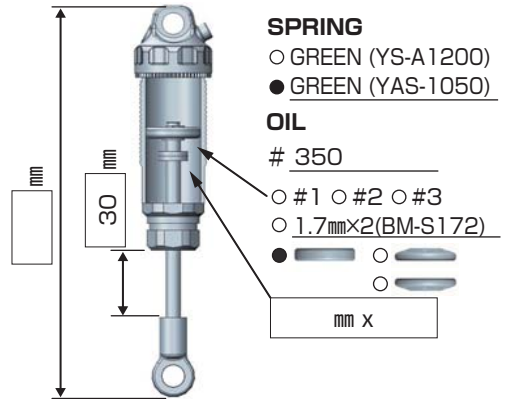
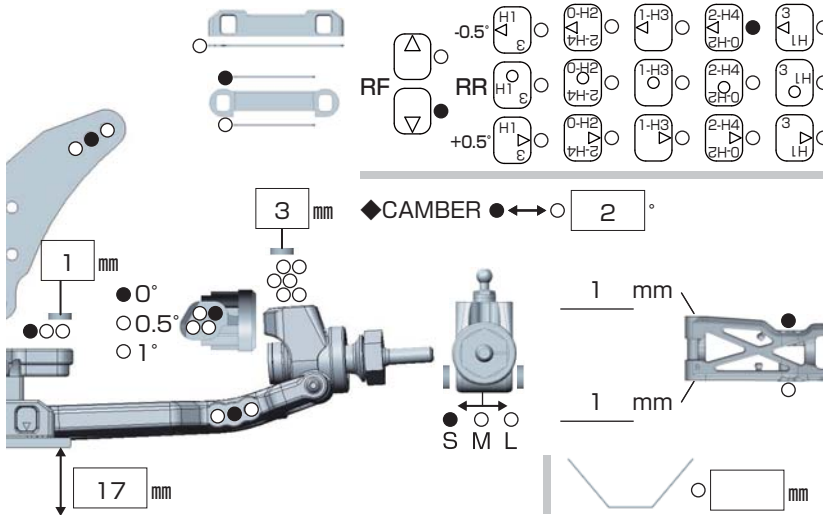

DRIVE



- MOTOR ⇨ Much more 6.5T ○ Bonded ○ Sintered mm
- GEAR ⇨ Spur 80 T / Pinion 22 T : 2.6
- BATTERY ⇨ Much more shorty
- ESC ○ Racing Performer X Series
- Much more

Battery placement

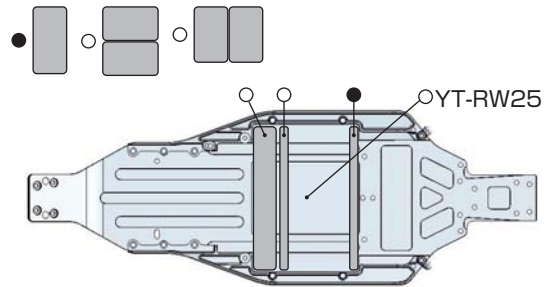

TIRE

- | | |
|-------------------------------|-----------------------------|
| FRONT | REAR |
| TIRE ⇨ Schumacher cut stagger | TIRE ⇨ Schumacher Mini pin |
| INSERTS ⇨ None | INSERTS ⇨ Schumacher medium |
| WHEELS ⇨ Schumacher | WHEELS ⇨ Schumacher |

OTHER

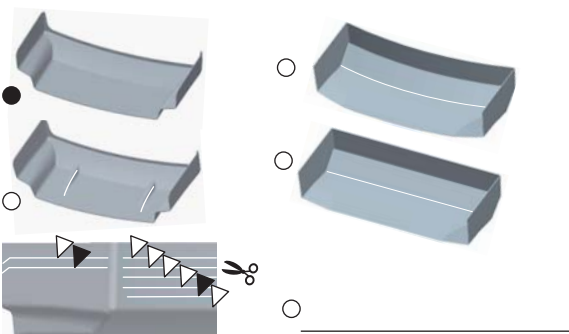

COMMENT

- | | | | |
|----------|----------|-----------|---------|
| B4-008R | B2-010RB | Z2-008GF | Z2-413A |
| Z2-415GS | Z2-101L | Z2-415R00 | Z2-S2SD |
| Z2-S2LD | Z2-670VP | BM-S162 | BM-S172 |
| Z2-TSS | Z2-TBS | YS-8BH | Z2-110 |
- Steering ackerman ball stud use short neck(ZC-206SHS) under the battery wight 100g
5.0mm front wheel hex(B4-011R)