

B-MAX4 II

Arn0

SETTING SHEET

Ver.01

DRIVER _____

DATE _____

CIRCUIT

- INDOOR OUTDOOR
 WET DRY DUSTY SMOOTH BUMPY OTHER
 LOW TRACTION MED TRACTION HIGH TRACTION
 CLAY GRASS BLUE GROOVE ASTROTURF DIRT CARPET WOOD

FRONT

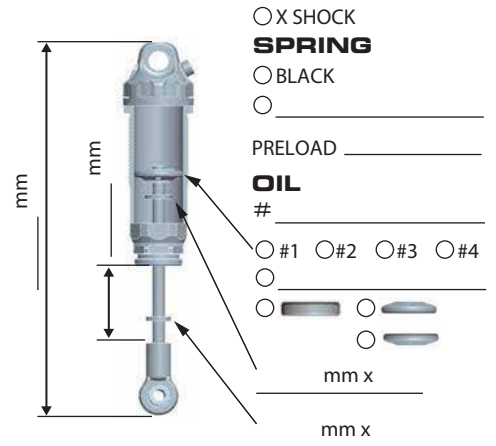
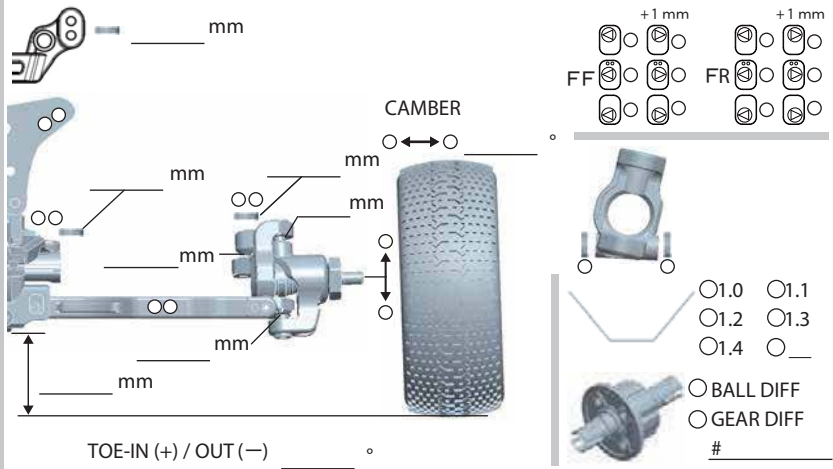

REAR

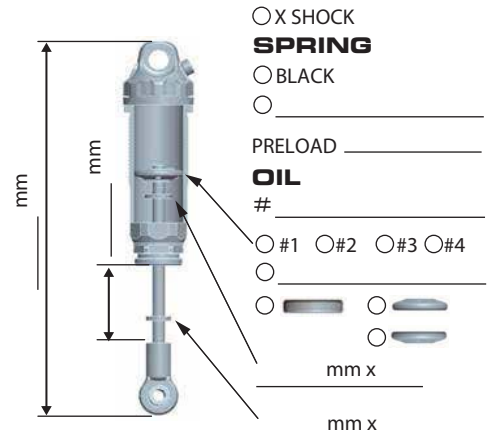
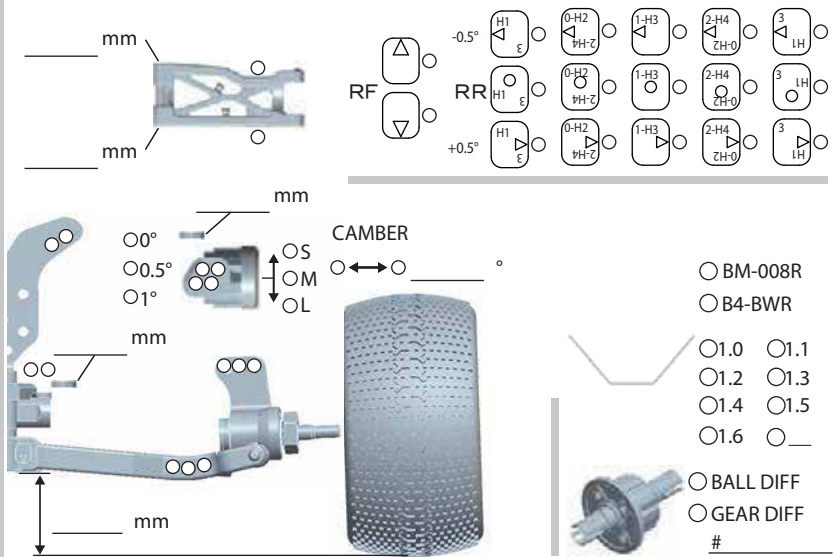

DRIVE

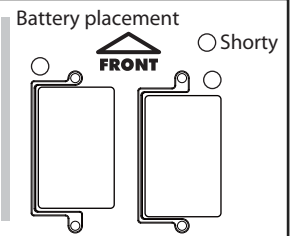
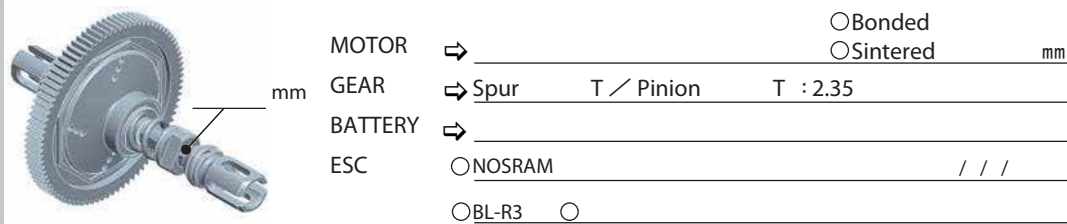

TIRE

FRONT

- TIRE _____
 INSERTS _____
 WHEELS _____

REAR

- TIRE _____
 INSERTS _____
 WHEELS _____

OTHER

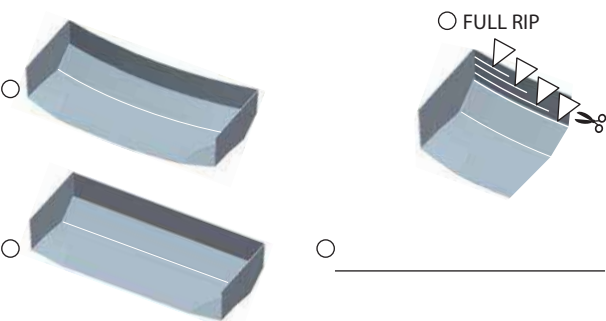

COMMENT
