

1/10 LUXURY ELECTRIC OFF-ROAD BUGGY 4WD

XTRAY XB4

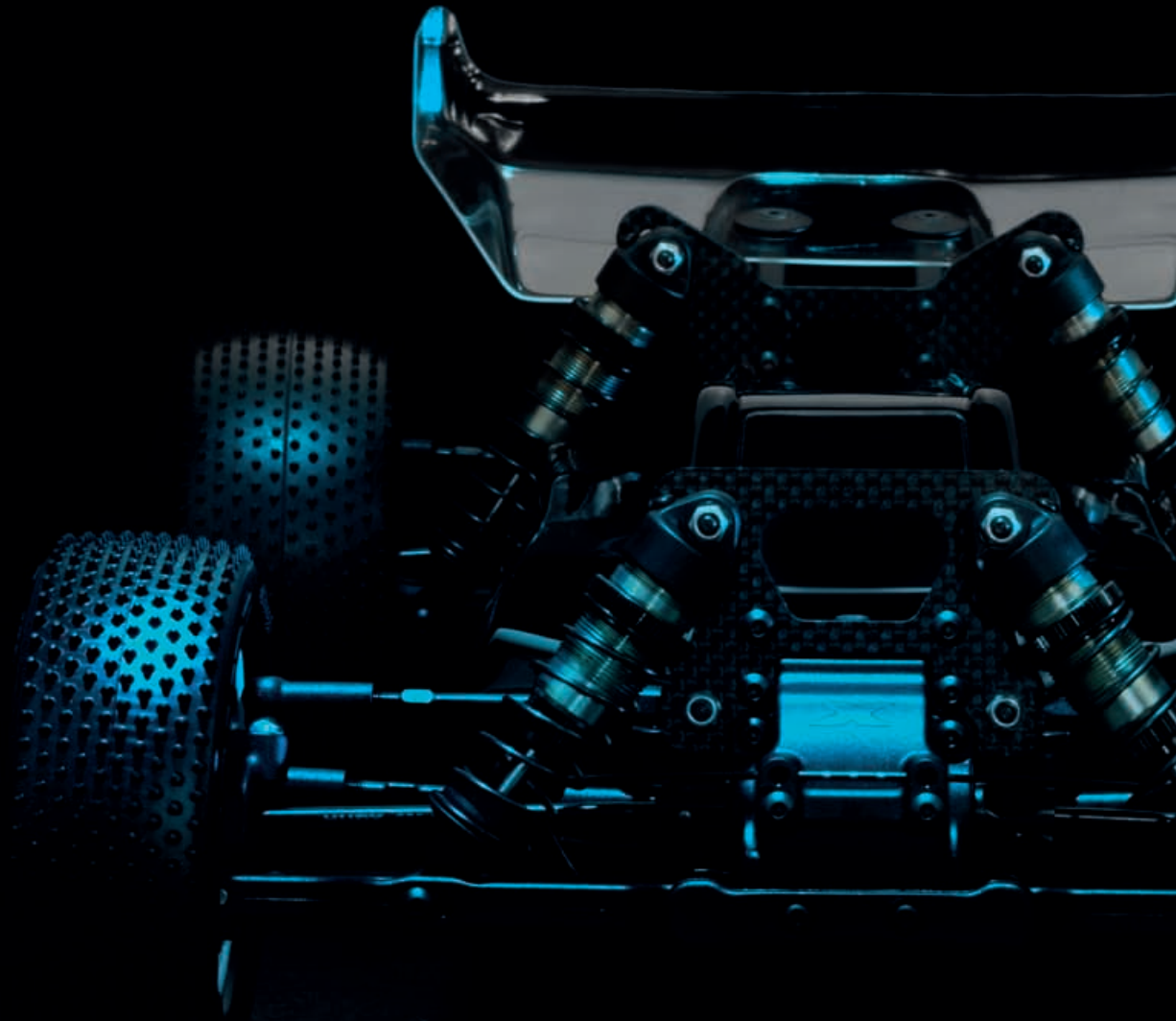

INSTRUCTION MANUAL
FOR XB4C'24 & XB4D'24 EDITION

BEFORE YOU START

This is a high-competition, high-quality RC car intended for persons aged 16 years and older with previous experience building and operating RC model racing cars. This is not a toy; it is a precision racing model. This model racing car is not intended for use by beginners, inexperienced customers, or by children without direct supervision of a responsible, knowledgeable adult. If you DO NOT fulfill these requirements, please return the kit in unused and unassembled form back to the shop where you have purchased it.

Before building and operating your XRAY, YOU MUST read through all of the operating instructions and instruction manual and fully understand them to get the maximum enjoyment and prevent unnecessary damage.

CUSTOMER SUPPORT

We have made every effort to make these instructions as easy to understand as possible. However, if you have any difficulties, problems, or questions, please DO NOT hesitate to contact the XRAY support team at info@teamxray.com. Also, please visit our Web site at www.teamxray.com to find the latest updates, set-up information, option parts, and many other goodies. We pride ourselves on taking excellent care of our customers.

You can join thousands of XRAY fans and enthusiasts in our online community at: www.teamxray.com

Read carefully and fully understand the instructions before beginning assembly.

Make sure you review this entire manual, download and use set-up book from the web, and examine all details carefully. If for some reason you decide this is not what you wanted or expected, DO NOT continue any further. Your hobby dealer can not accept your kit for return or exchange after it has been partially or fully assembled.

Contents of the box may differ from pictures. In line with our policy of continuous product development, the exact specifications of the kit may vary without prior notice.

XRAY Europe

K Vystavisku 6992
91101 Trenčín
Slovakia, EUROPE
Phone: 421-32-7401100
Fax: 421-32-7401109
E-mail: info@teamxray.com

XRAY USA

RC America, 2030 Century Center Blvd #15
Irving, TX 75062
USA
Phone: (214) 744-2400
Fax: (214) 744-2401
E-mail: xray@rcamerica.com

FAILURE TO FOLLOW THESE INSTRUCTIONS WILL BE CONSIDERED AS ABUSE AND/OR NEGLECT.

SAFETY PRECAUTIONS

Contains:

LEAD (CAS 7439-92-1) ANTIMONY (CAS 7440-36-0)

WARNING: This product contains a chemical known to the state of California to cause cancer and birth defects or other reproductive harm.

CAUTION: CANCER HAZARD

Contains lead, a listed carcinogen. Lead is harmful if ingested. Wash thoroughly after using. DO NOT use product while eating, drinking or using tobacco products. May cause chronic effects to gastrointestinal tract, CNS, kidneys, and blood. MAY CAUSE BIRTH DEFECTS.

When building, using and/or operating this model always wear protective glasses and gloves.

Take appropriate safety precautions prior to operating this model. You are responsible for this model's assembly and safe operation! Please read the instruction manual before building and operating this model and follow all safety precautions. Always keep the instruction manual at hand for quick

reference, even after completing the assembly. Use only genuine and original authentic XRAY parts for maximum performance. Using any third party parts on this model will void guaranty immediately.

Improper operation may cause personal and/or property damage. XRAY and its distributors have no control over damage resulting from shipping, improper construction, or improper usage. XRAY assumes and accepts no responsibility for personal and/or property damages resulting from the use of improper building materials, equipment and operations. By purchasing any item produced by XRAY, the buyer expressly warrants that he/she is in compliance with all applicable federal, state and local laws and regulation regarding the purchase, ownership and use of the item. The buyer expressly agrees to indemnify and hold harmless XRAY for all claims resulting directly or indirectly from the purchase, ownership or use of the product. By the act of assembling or operating this product, the user accepts all resulting liability. If the buyer is not prepared to accept this liability, then he/she should return this kit in new, unassembled, and unused condition to the place of purchase.



IMPORTANT NOTES - GENERAL

- This product is not suitable for children under 16 years of age without the direct supervision of a responsible and knowledgeable adult.
- Carefully read all manufacturers warnings and cautions for any parts used in the construction and use of your model.
- Assemble this kit only in places away from the reach of very small children.
- First-time builders and users should seek advice from people who have building experience in order to assemble the model correctly and to allow the model to reach its performance potential.
- Exercise care when using tools and sharp instruments.
- Take care when building, as some parts may have sharp edges.
- Keep small parts out of reach of small children. Children must not be allowed to put any parts in their mouth, or pull vinyl bag over their head.
- Read and follow instructions supplied with paints and/or cement, if used (not included in kit).
- Immediately after using your model, DO NOT touch equipment on the model such as the motor and speed controller, because they generate high temperatures. You may seriously burn yourself seriously touching them.
- Follow the operating instructions for the radio equipment at all times.
- DO NOT put fingers or any objects inside rotating and moving parts, as this may cause damage or serious injury as your finger, hair, clothes, etc. may get caught.
- Be sure that your operating frequency is clear before turning on or running your model, and never share the same frequency with somebody else at the same time. Ensure that others are aware of the operating frequency you are using and when you are using it.
- Use a transmitter designed for ground use with RC cars. Make sure that no one else is using the same frequency as yours in your operating area. Using the same frequency at the same time, whether it is driving, flying or sailing, can cause loss of control of the RC model, resulting in a serious accident.
- Always turn on your transmitter before you turn on the receiver in the car. Always turn off the receiver before turning your transmitter off.
- Keep the wheels of the model off the ground when checking the operation of the radio equipment.
- Disconnect the battery pack before storing your model.
- When learning to operate your model, go to an area that has no obstacles that can damage your model if your model suffers a collision.
- Remove any sand, mud, dirt, grass or water before putting your model away.
- If the model behaves strangely, immediately stop the model, check and clear the problem.
- To prevent any serious personal injury and/or damage to property, be responsible when operating all remote controlled models.
- The model car is not intended for use on public places and roads or areas where its operation can conflict with or disrupt pedestrian or vehicular traffic.
- Because the model car is controlled by radio, it is subject to radio interference from many sources that are beyond your control. Since radio interference can cause momentary loss of control, always allow a safety margin in all directions around the model in order to prevent collisions.
- DO NOT use your model:
 - Near real cars, animals, or people that are unaware that an RC car is being driven.
 - In places where children and people gather
 - In residential districts and parks
 - In limited indoor spaces
 - In wet conditions
 - In the street
 - In areas where loud noises can disturb others, such as hospitals and residential areas.
 - At night or anytime your line of sight to the model may be obstructed or impaired in any way.

To prevent any serious personal injury and/or damage to property, please be responsible when operating all remote controlled models.

IMPORTANT NOTES - ELECTRICAL

- Insulate any exposed electrical wiring (using heat shrink tubing or electrical tape) to prevent dangerous short circuits. Take maximum care in wiring, connecting and insulating cables. Make sure cables are always connected securely. Check connectors for if they become loose. And if so, reconnect them securely. Never use RC models with damaged wires. A damaged wire is extremely dangerous, and can cause short-circuits resulting in fire. Please have wires repaired at your local hobby shop.
- Low battery power will result in loss of control. Loss of control can occur due to a weak battery in either the transmitter or the receiver. Weak running battery may also result in an out of control car if your car's receiver power is supplied by the running battery. Stop operation immediately if the car starts to slow down.
- When not using RC model, always disconnect and remove battery.
- DO NOT disassemble battery or cut battery cables. If the running battery short-circuits, approximately 300W of electricity can be discharged, leading to fire or burns. Never disassemble battery or cut battery cables.
- Use a recommended charger for the receiver and transmitter batteries and follow the instructions correctly. Over-charging, incorrect charging,

or using inferior chargers can cause the batteries to become dangerously hot. Recharge battery when necessary. Continual recharging may damage battery and, in the worst case, could build up heat leading to fire. If battery becomes extremely hot during recharging, please ask your local hobby shop for check and/or repair and/or replacement.

- Regularly check the charger for potential hazards such as damage to the cable, plug, casing or other defects. Ensure that any damage is rectified before using the charger again. Modifying the charger may cause short-circuit or overcharging leading to a serious accident. Therefore DO NOT modify the charger.
- Always unplug charger when recharging is finished.
- DO NOT recharge battery while battery is still warm. After use, battery retains heat. Wait until it cools down before charging.
- DO NOT allow any metal part to short circuit the receiver batteries or other electrical/electronic device on the model.
- Immediately stop running if your RC model gets wet as may cause short circuit.
- Please dispose of batteries responsibly. Never put batteries into fire.

R/C & BUILDING TIPS

- Make sure all fasteners are properly tightened. Check them periodically.
- Make sure that chassis screws DO NOT protrude from the chassis.
- For the best performance, it is very important that great care is taken to ensure the free movement of all parts.
- Clean all ball-bearings so they move very easily and freely.
- Tap or pre-thread the plastic parts when threading screws.
- Self-tapping screws cut threads into the parts when being tightened. DO NOT use excessive force when tightening the self-tapping screws because you may strip out the thread in the plastic. We recommended you stop tightening a screw when you feel some resistance.
- Ask your local hobby shop for any advice.

Please support your local hobby shop. We at XRAY Model Racing Cars support all local hobby dealers. Therefore we ask you, if at all possible, to purchase XRAY products at your hobby dealer and give them your support like we do. If you have difficulty finding XRAY products, please check out www.teamxray.com to get advice, or contact us via email at info@teamxray.com, or contact the XRAY distributor in your country.

WARRANTY

XRAY guarantees this model kit to be free from defects in both material and workmanship within 30 days of purchase. The total monetary value under warranty will in no case exceed the cost of the original kit purchased. This warranty DOES NOT cover any components damaged by use or modification or as a result of wear. Part or parts missing from this kit must be reported within 30 days of purchase. No part or parts will be sent under warranty without proof of purchase. Should you find a defective or missing part, contact the local distributor. Service and customer support will be provided through local hobby store where you have purchased the kit, therefore make sure to purchase any XRAY products at your local hobby store. This model racing car is considered to be a high-performance racing vehicle. As such this vehicle will be used in an extreme range of conditions and situations, all which may cause premature wear or failure of any component. XRAY has no control over usage of vehicles once they leave the dealer, therefore XRAY can only offer warranty against all manufacturer's defects in materials, workmanship, and assembly at point of sale and before use. No warranties are expressed or implied that cover damage caused by what is considered normal use, or cover or imply how long any model cars' components or electronic components will last before requiring replacement.

Due to the high performance level of this model car you will need to periodically maintain and replace consumable components. Any and all warranty coverage will not cover replacement of any part or component damaged by neglect, abuse, or improper or unreasonable use. This includes but is not limited to damage from crashing, chemical and/or water damage, excessive moisture, improper or no maintenance, or user modifications which

compromise the integrity of components. Warranty will not cover components that are considered consumable on RC vehicles. XRAY DOES NOT pay nor refund shipping on any component sent to XRAY or its distributors for warranty. XRAY reserves the right to make the final determination of the warranty status of any component or part.

Limitations of Liability

XRAY makes no other warranties expressed or implied. XRAY shall not be liable for any loss, injury or damages, whether direct, indirect, special, incidental, or consequential, arising from the use, misuse, or abuse of this product and/or any product or accessory required to operate this product. In no case shall XRAY's liability exceed the monetary value of this product.

Take adequate safety precautions prior to operating this model. You are responsible for this model's assembly and safe operation.

Disregard of the any of the above cautions may lead to accidents, personal injury, or property damage. XRAY MODEL RACING CARS assumes no responsibility for any injury, damage, or misuse of this product during assembly or operation, nor any additions that may arise from the use of this product.

All rights reserved.

QUALITY CERTIFICATE

XRAY MODEL RACING CARS uses only the highest quality materials, the best compounds for molded parts and the most sophisticated manufacturing processes of TQM (Total Quality Management). We guarantee that all parts of a newly-purchased kit are manufactured with the highest regard to quality. However, due to the many factors inherent in model racecar competition, we

cannot guarantee any parts once you start racing the car. Products which have been worn out, abused, neglected or improperly operated will not be covered under warranty.

We wish you enjoyment of this high-quality and high-performance RC car and wish you best success on the track!

In line with our policy of continuous product development, the exact specifications of the kit may vary. In the unlikely event of any problems with your new kit, you should contact the model shop where you purchased it, quoting the part number.

We do reserve all rights to change any specification without prior notice. All rights reserved.

TOOLS REQUIRED



Combination Pliers
(HUDY #189020)



Side Cutters
(HUDY #189010)



Pocket Hobby Knife (HUDY #188981)



Special Tool for turnbuckles, nuts (HUDY #181090)



Turnbuckle Wrench 3mm (HUDY #181030)



HUDY Tweezers Straight (HUDY #188970)



HUDY Tweezers Curved (HUDY #188971)



Allen 1.5mm (#111545 - HUDY EXCLUSIVE Limited Edition)



Allen 2.0mm (#112045 - HUDY EXCLUSIVE Limited Edition)



Arm Reamer 3.0mm (#107643 - HUDY EXCLUSIVE Limited Edition)



Socket 5.5mm (#175535 - HUDY EXCLUSIVE Limited Edition)



Socket 7.0mm (#177035 - HUDY EXCLUSIVE Limited Edition)



Reamer (#107602 - HUDY EXCLUSIVE Limited Edition)



Scissors (HUDY #188990)



Professional Multi Tool
(HUDY #183011)

EQUIPMENT INCLUDED * Kit includes smaller but sufficient amount of oil and grease to build the car.

300cSt (#106330)
HUDY Premium
Silicone Oils



400cSt (#106340)
HUDY Premium
Silicone Oils



550cSt (#106355)
HUDY Premium
Silicone Oils



10.000cSt (#106510)
HUDY Premium
Silicone Oils



7.000cSt (#106470)
HUDY Premium
Silicone Oils



100.000cSt (#106610)
HUDY Premium
Silicone Oils



(HUDY #106210)
Premium
Graphite Grease



EQUIPMENT REQUIRED

Transmitter



Receiver



Speed Controller



Steering Servo



Electric Motor & Pinion Gear
with Setscrew

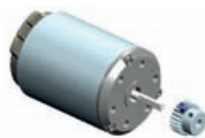

LiPo Battery



Battery Charger



Double-sided Tape
(HUDY #107875)



Lexan™ Paint



4x Tires & Inserts



Bearing Oil
(HUDY #106230)



Threadlock



CA glue



NOT INCLUDED



Follow Set-Up Book:

To ensure that you always have access to the most up-to-date version of the Set-up Book you can download the HUDY Set-up Book from their web site at [www.hudy.net] By offering this online version instead of including a hardcopy printed version in kits, you will always be assured of having the most current updated version.



SAMPLE OF OPTIONAL PARTS

#36XXXX	TYPE1	OPTION 1
#36XXXX	TYPE2	OPTION 2
#36XXXX	TYPE	INCLUDED
#36XXXX	TYPE3	OPTION 3

XRAY offers wide range of optional tuning parts which are listed in a table like this. Please refer to the exploded view of each main section to verify which part is included in the kit while all other parts are available only as an optional part and must be purchased separately.

COLOR INDICATIONS

At the beginning of each section is an exploded view of the parts to be assembled. There is also a list of all the parts and part numbers that are related to the assembly of that section.

The part descriptions are color-coded to make it easier for you to identify the source of a part. Here are what the different colors mean:

361201

STYLE A - indicates parts that are included in the bag marked for the section.

361113

STYLE B - indicates parts that are included in the box.

364903

STYLE C - indicates parts that are already assembled from previous steps.

365100

STYLE D - indicates parts that are optional.

TECH TIPS

TIP DRIVE SHAFT PIN SERVICING

To enjoy the longest possible lifespan of the drive shafts and diff outdrives, it is extremely important to properly service the drive shaft pins. Inspect the pins after every 3 hours of runtime. If the pins show any wear, replace them with new pins.



DO NOT use drive shafts when the pins are worn.

Press out the worn pins.

Press in new pins and regularly inspect for wear.



For quick & easy drive pin replacements use #106000 HUDY Drive Pin Replacement Tool together with #106036 Ejector Pivot Pin & Alternating Pivot 2.5mm.



To replace the worn pins use only premium HUDY drive pins (#106053 2.5mm dia x 10mm length)

TIP GRAPHITE PARTS PREPARATION

Follow this Tech Tip to prepare the graphite parts. Sand the edges with sandpaper, and then seal the edges with CA glue to reinforce them and help prevent delamination.

Prepare all Graphite Parts:

- Front shock tower
- Rear shock tower

Fine sandpaper

Use fine sandpaper to sand smooth the edges of all graphite parts.

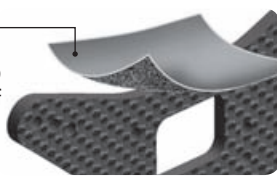

Apply CA glue to all edges of the graphite parts.

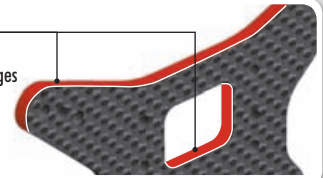

MANUAL STEPS ONLY FOR DIRT

1. BALL DIFFERENTIAL **DIRT**

MANUAL STEPS ONLY FOR CARPET

1. GEAR DIFFERENTIAL **CARPET**

MANUAL DUAL STEPS FOR CARPET AND DIRT

3. REAR DRIVETRAIN **CARPET** **DIRT**

1. FRONT & REAR DIFFERENTIAL

CARPET DIRT

#364941
OPTION
 STEEL DIFFERENTIAL BEVEL GEAR FOR LARGE VOLUME DIFF 41T



#335080
OPTION
 STEEL DIFFERENTIAL PIN HARDCOATED (2)

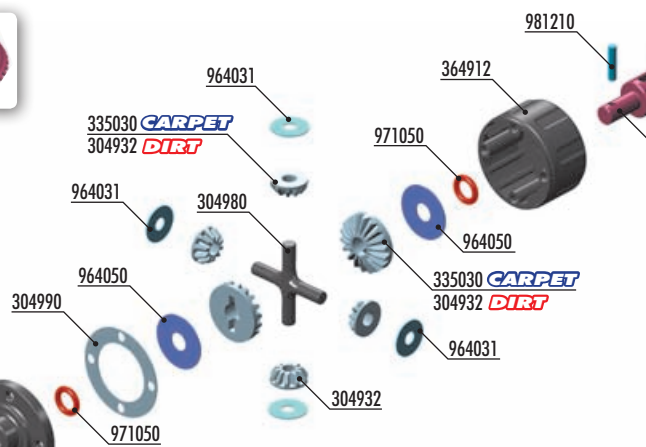

#335081
OPTION
 ALU DIFFERENTIAL PIN HARDCOATED (2)

#365100
OPTION
 XRAY XB4 ACTIVE DIFFERENTIAL FRONT/REAR - SET



ACTIVE DIFF SEGMENTS			
#325123	60°		OPTION
#325125	90°		INCLUDED
#325127	120°		OPTION

#364912-G
OPTION
 GEAR DIFFERENTIAL CASE - LARGE VOLUME - GRAPHITE



#364920-G
OPTION
 GEAR DIFFERENTIAL COVER - LARGE VOLUME - GRAPHITE



BAG
01
2x
 Gear Differentials

- 304980 COMPOSITE GEAR DIFF CROSS PIN
- 304990 DIFF GASKET (4)
- 364903 GEAR DIFFERENTIAL - LARGE VOLUME - SET
- 364912 COMPOSITE GEAR DIFFERENTIAL CASE - LARGE VOLUME
- 364920 COMPOSITE GEAR DIFFERENTIAL COVER - LARGE VOLUME
- 364940 STEEL DIFFERENTIAL BEVEL GEAR FOR LARGE VOLUME DIFF 40T
- 364962 GEAR DIFF OUTDRIVE ADAPTER FOR LARGE VOLUME DIFF (2)
- 903258 HEX SCREW SFH M2.5x8 (10)
- 941014 BALL-BEARING 10x15x4 RUBBER SEALED - GREASE (2)

- 964031 WASHER S 3.5x10x0.2 (10)
 - 964050 WASHER S 5x15x0.3 (10)
 - 971050 SILICONE O-RING 5x1.5 (10)
 - 981210 PIN 2x10 (10)
- DIRT**
 304932 GRAPHITE GEAR DIFF BEVEL & SATELLITE GEARS (2+4)
- CARPET**
 335030 STEEL DIFF BEVEL & SATELLITE GEARS (2+4)

2x

1x 964050
S 5x15x0.3

1x 971050
O 5x1.5

1x 981210
P 2x10

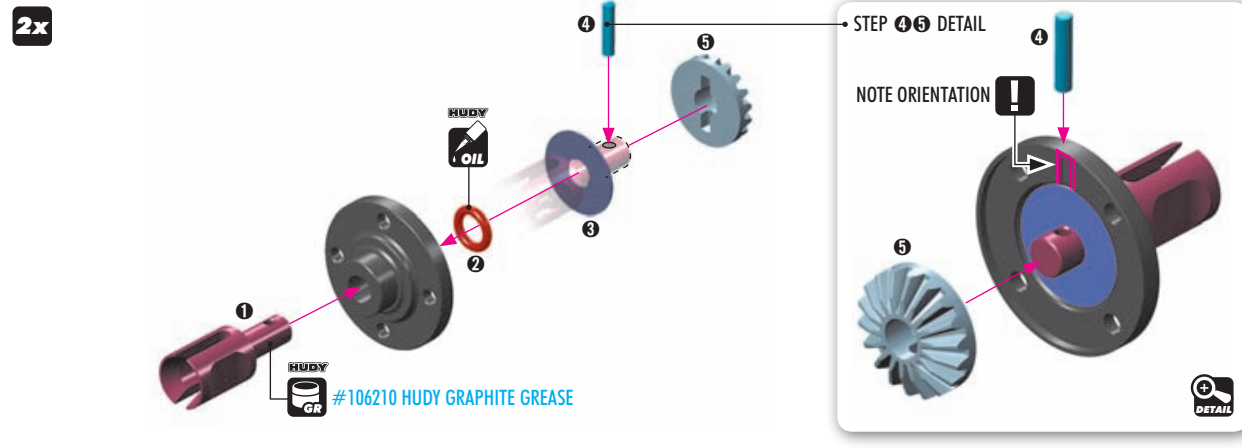

2x

1x 964050
S 5x15x0.3

1x 971050
O 5x1.5

1x 981210
P 2x10

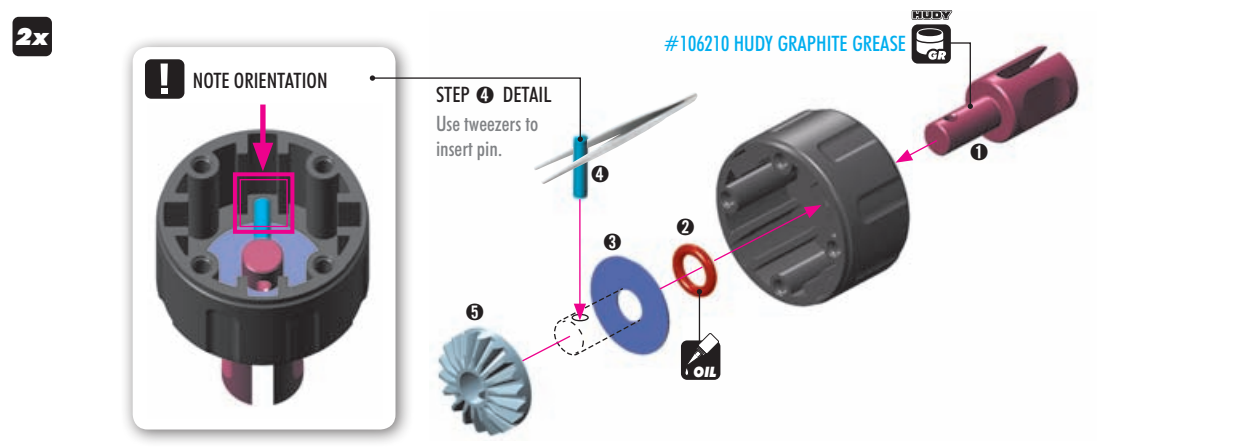

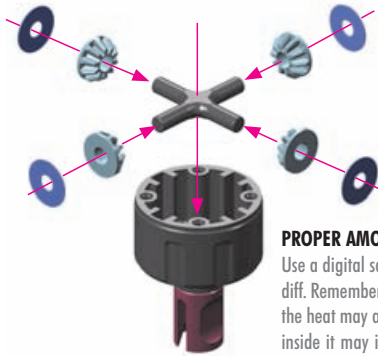

PROPER AMOUNT OF OIL IN THE DIFFS

Use a digital scale to measure the exact amount of oil in the diff. Remember that during operation the diff gets hotter and the heat may allow the oil to expand. If there is too much oil inside it may interfere with the diff operation and damage the internal gears.

Front diff Silicone oil
CARPET 10.000cSt
DIRT 7.000cSt
 Fill just above the cross-pins.

Rear diff Silicone oil
CARPET 10.000cSt
DIRT 7.000cSt
 Fill just above the cross-pins.

⌚ Wait 5min

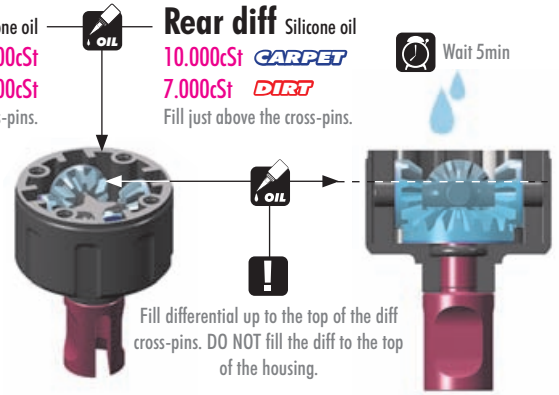

TO ENSURE YOU HAVE THE SAME AMOUNT OF OIL FROM REBUILD TO REBUILD, DO THE FOLLOWING:



1 Put the diff (without oil) on the scale and check the weight.

$$16.97g + 1.80g = 18.77g$$

$$11.47g + 1.80g = 13.27g$$

2 Slowly pour oil into the diff and watch the weight. Add 1.80g of oil into the diff.

#107865
 OPTION HUDY Professional Digital Pocket Scale 300g/0.01g

#107866
 OPTION HUDY Professional Digital Pocket Scale 3000g/0.1g

TIPS FOR DIFFERENTIALS

TIP	FRONT DIFFERENTIAL	REAR DIFFERENTIAL	TIP
	LOW TRACTION 7.000cSt (HUDY #106470)	LOW TRACTION 7.000cSt (HUDY #106470)	
	MEDIUM-HIGH TRACTION 10.000cSt (HUDY #106510)	MEDIUM-HIGH TRACTION 10.000cSt (HUDY #106510)	
	SUPER-HIGH TRACTION 15.000cSt (HUDY #106515)	SUPER-HIGH TRACTION 15.000cSt (HUDY #106515)	
NOTE:	Softer oil increases steering, harder oil increases stability.	NOTE:	Softer oil increases rear traction, harder oil increases on-power steering.

SET-UP BOOK

DIFFERENTIAL OIL



2x 941014 BB 10x15x4

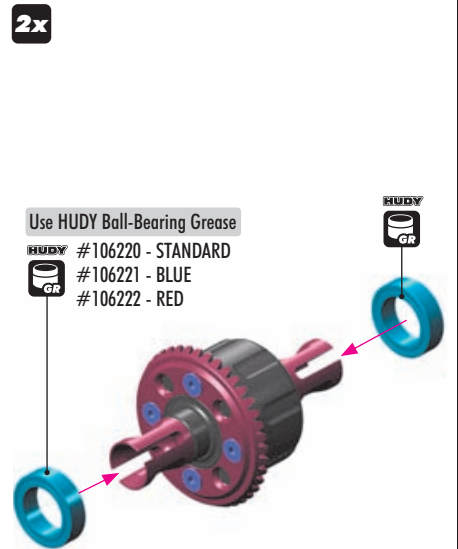
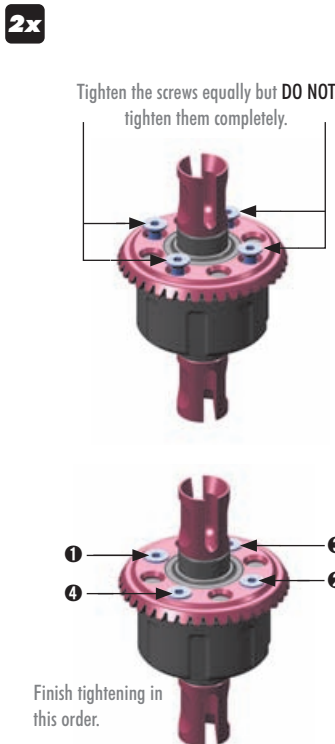
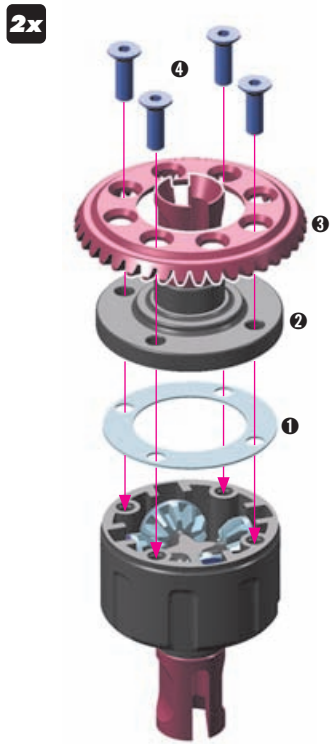

1. CENTER GEAR DIFFERENTIAL

DIRT

#365101 XRAY XB4 ACTIVE DIFFERENTIAL - CENTER - SET
OPTION



ACTIVE DIFF SEGMENTS			
#325123	60°		OPTION
#325125	90°		INCLUDED
#325127	120°		OPTION

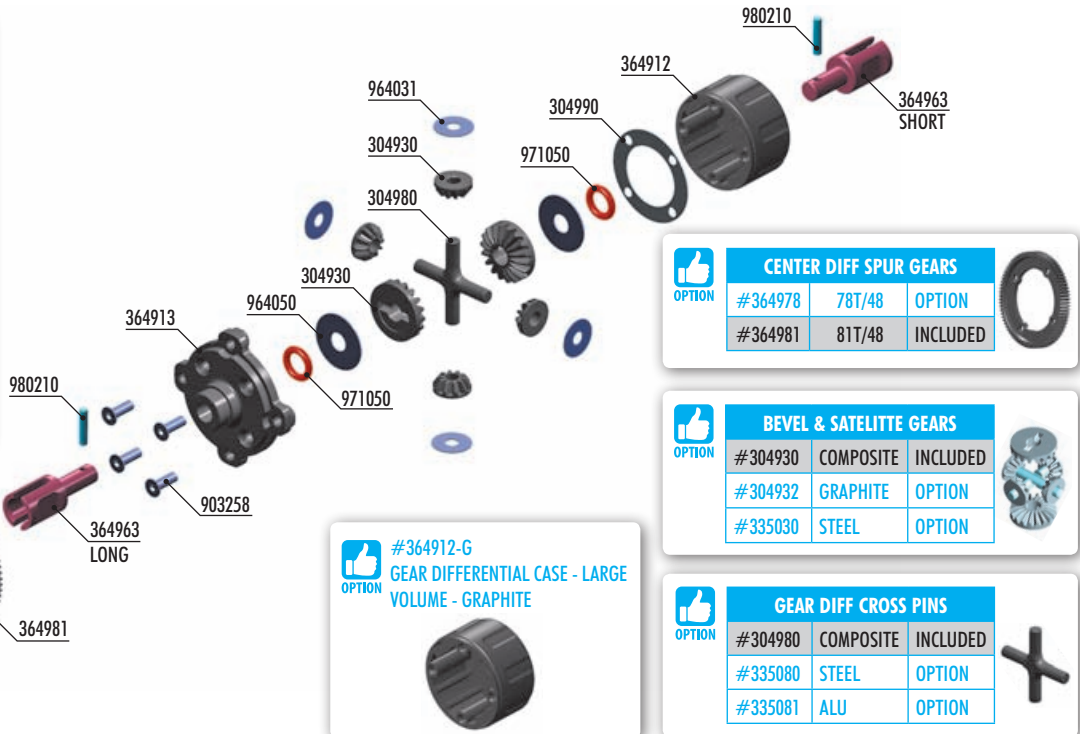

CENTER DIFF SPUR GEARS			
#364978	78T/48	OPTION	
#364981	81T/48	INCLUDED	

BEVEL & SATELLITE GEARS			
#304930	COMPOSITE	INCLUDED	
#304932	GRAPHITE	OPTION	
#335030	STEEL	OPTION	

#364912-G
GEAR DIFFERENTIAL CASE - LARGE VOLUME - GRAPHITE
OPTION

GEAR DIFF CROSS PINS			
#304980	COMPOSITE	INCLUDED	
#335080	STEEL	OPTION	
#335081	ALU	OPTION	

BAG
01.3

- 304930 COMPOSITE GEAR DIFF BEVEL & SATELLITE GEARS (2+4)
- 304980 COMPOSITE GEAR DIFF CROSS PIN
- 304990 DIFF GASKET (4)
- 364904 GEAR CENTER DIFFERENTIAL - LARGE VOLUME - SET
- 364912 COMPOSITE GEAR DIFFERENTIAL CASE - LARGE VOLUME
- 364913 COMPOSITE CENTER GEAR DIFF ADAPTER - LARGE VOLUME
- 364963 CENTER GEAR DIFF OUTDRIVE ADAPTER FOR LARGE VOLUME DIFF (1+1)
- 364981 COMPOSITE CENTER DIFF SPUR GEAR 81T / 48

- 902306 HEX SCREW SH M3x6 (10)
- 903258 HEX SCREW SFH M2.5x8 (10)
- 964031 WASHER S 3.5x10x0.2 (10)
- 964050 WASHER S 5x15x0.3 (10)
- 971050 SILICONE O-RING 5x1.5 (10)
- 980210 PIN 2x10 (10)

- 1x 964050 S 5x15x0.3
- 1x 971050 O 5x1.5
- 1x 980210 P 2x10

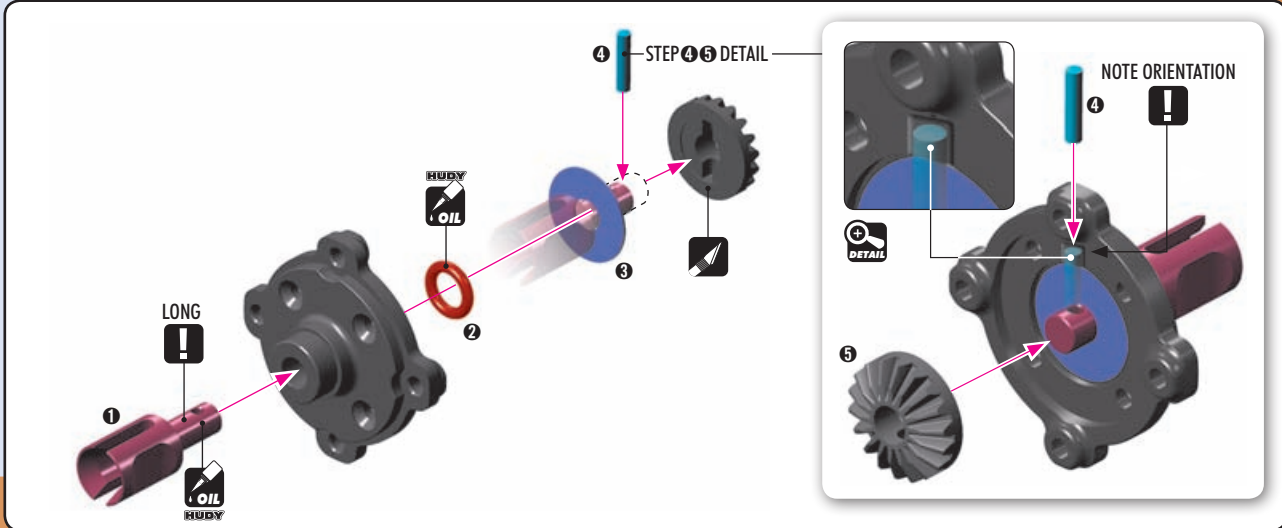

- 1x 964050 S 5x15x0.3
- 1x 971050 O 5x1.5
- 1x 980210 P 2x10

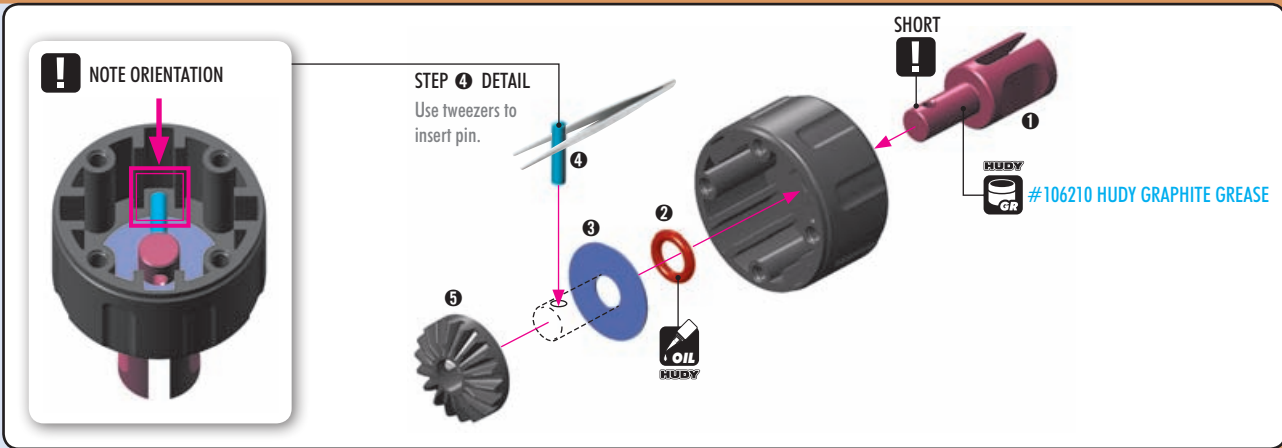

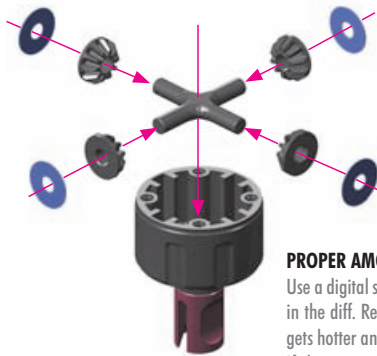

PROPER AMOUNT OF OIL IN THE DIFFS

Use a digital scale to measure the exact amount of oil in the diff. Remember that during operation the diff gets hotter and the heat may allow the oil to expand. If there is too much oil inside it may interfere with the diff operation and damage the internal gears.



TO ENSURE YOU HAVE THE SAME AMOUNT OF OIL FROM REBUILD TO REBUILD, DO THE FOLLOWING:



1 Put the diff (without oil) on the scale and check the weight (approximately 11.72g)



2 Slowly pour oil into the diff and watch the weight.

$$\text{CENTER Diff. } 11.72\text{g} + 1.50\text{g} = 13.22\text{g}$$

#107865
OPTION HUDY Professional Digital Pocket Scale 300g/0.01g

#107866
OPTION HUDY Professional Digital Pocket Scale 3000g/0.1g

TIP FOR CENTER DIFFERENTIAL

LOW TRACTION	50.000cSt (HUDY #106550)
MEDIUM TRACTION	100.000cSt (HUDY #106610)
HIGH TRACTION	500.000cSt (HUDY #106650)

NOTE:
Softer oil increases steering, harder oil increases stability.

SET-UP BOOK

DIFFERENTIAL OIL

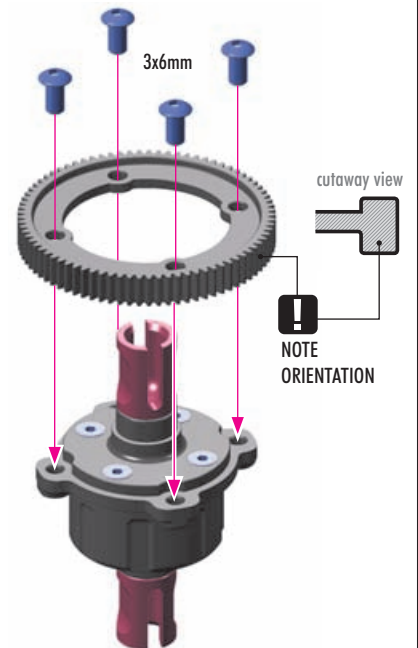
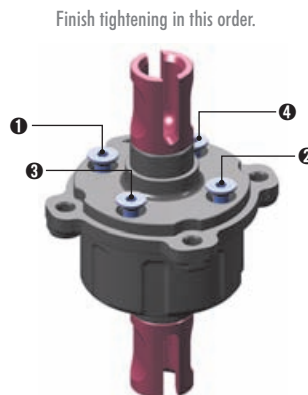
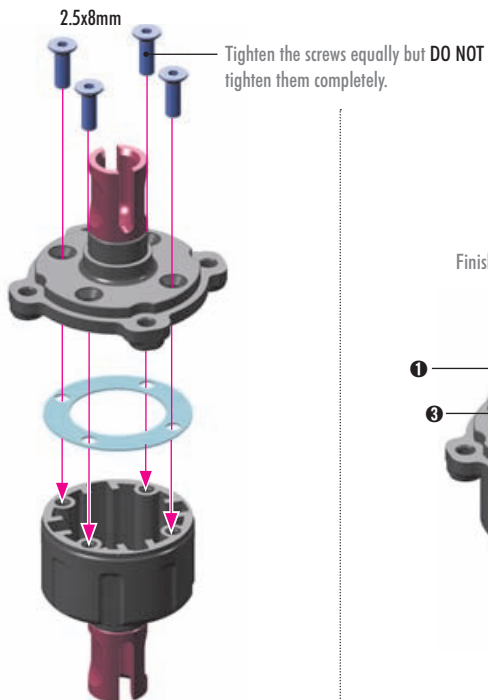
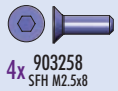

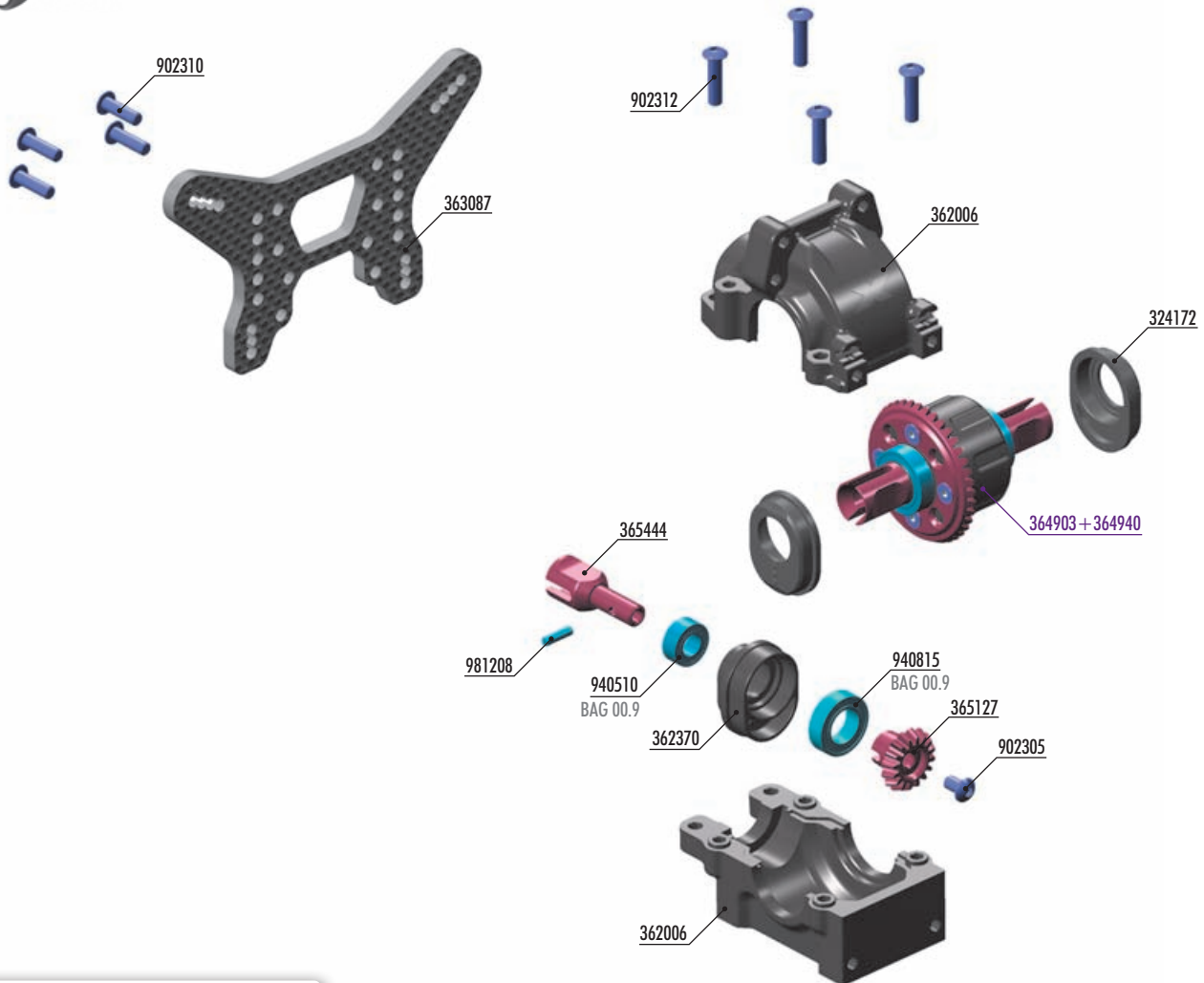
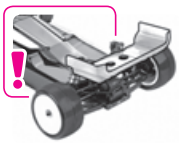

XRAY BALL-BEARINGS			
OPTION	#359050	5x10x4	GREASE OPTION
	#940510	5x10x4	OIL INCLUDED
	#940814	8x14x4	GREASE OPTION
	#940815	8x14x4	OIL INCLUDED

BALL-BEARING HUBS			
OPTION	#324172	1 DOT	OPTION
	#324172	2 DOTS	OPTION
	#324172	3 DOTS	INCLUDED

INLINE HUBS - REAR			
OPTION	#362370	1 DOT	OPTION
	#362370	2 DOTS	OPTION
	#362370	3 DOTS	INCLUDED

OPTION #365100 XRAY XB4 ACTIVE DIFFERENTIAL FRONT/REAR - SET



ACTIVE DIFF SEGMENTS			
OPTION	#325123	60°	OPTION
	#325125	90°	INCLUDED
	#325127	120°	OPTION



324172 COMPOSITE ADJUSTMENT BALL-BEARING HUB (2)
 362006 DIFF BULKHEAD - HORIZONTAL SPLIT DESIGN (HS) - FRONT/REAR - SET
 362370 INLINE HUB FOR BEVEL DRIVE GEAR - REAR HS BULKHEAD - 1+2+3 DOTS
 363087 GRAPHITE SHOCK TOWER FOR HS BULKHEAD - REAR - 3.5MM - LOWER
 365127 STEEL BEVEL DRIVE GEAR - FOR HS BULKHEAD - CNC-MACHINED - 16T
 365444 CENTRAL DOGBONE SHAFT UNIVERSAL JOINT - HUDY SPRING STEEL™

902305 HEX SCREW SH M3x5 (10)
 902310 HEX SCREW SH M3x10 (10)
 902312 HEX SCREW SH M3x12 (10)
 940510 BALL-BEARING 5x10x4 RUBBER SEALED - OIL (2)
 940815 BALL-BEARING 8x14x4 RUBBER SEALED - OIL (2)
 981208 PIN 2x8 (10)

364903 GEAR DIFFERENTIAL - LARGE VOLUME - SET
 364940 STEEL DIFFERENTIAL BEVEL GEAR FOR LARGE VOLUME DIFF 40T

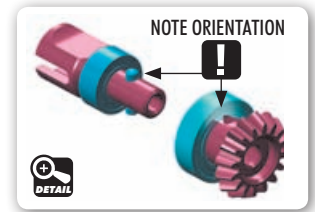
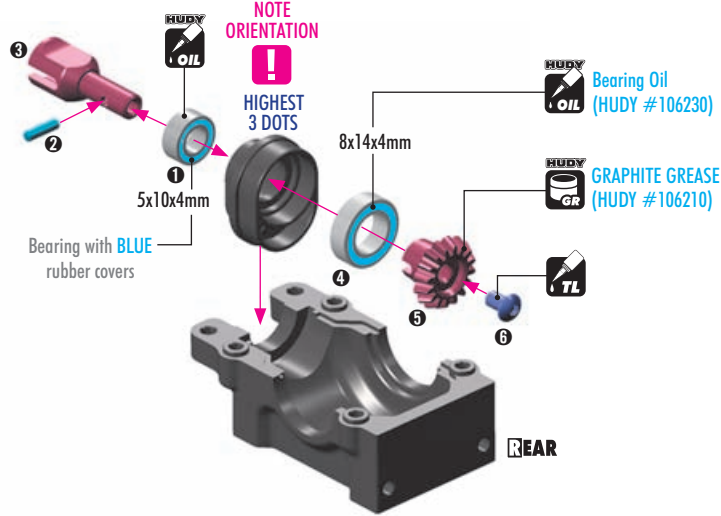

CARPET BEVEL DRIVE GEAR & DIFFERENTIAL HEIGHT ADJUSTMENT INITIAL SETTING

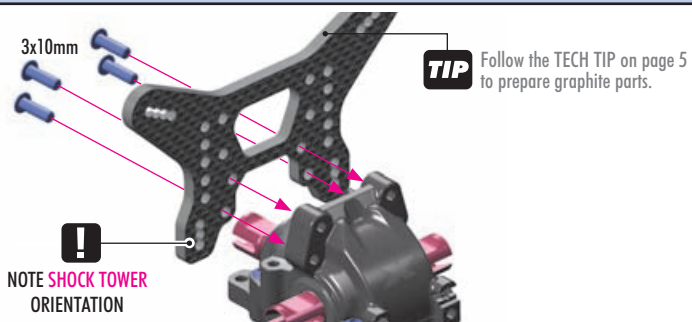
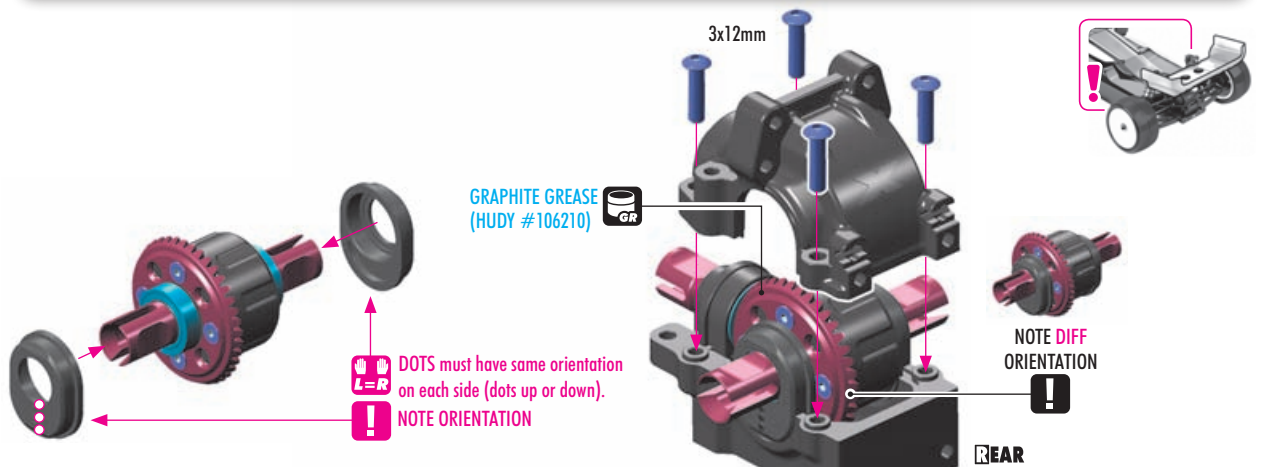
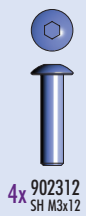
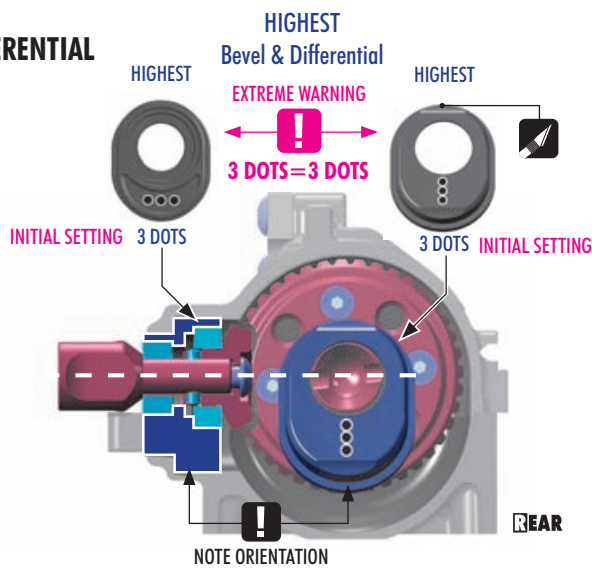

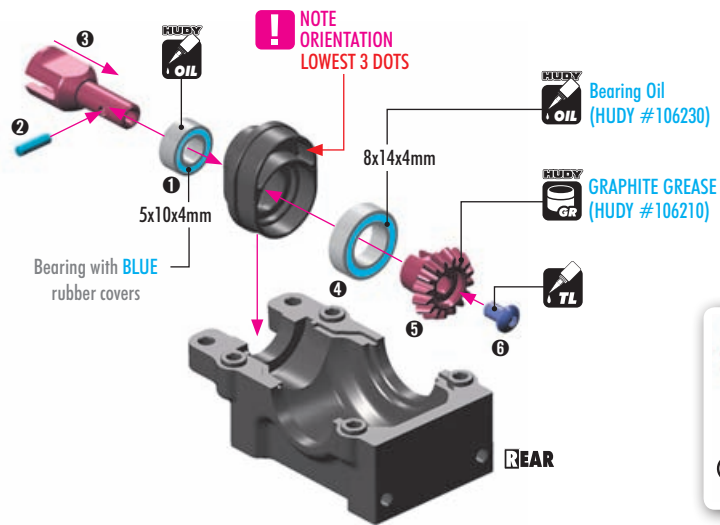
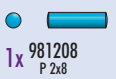
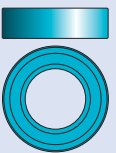
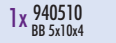
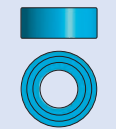

DIRT REAR BEVEL DRIVE GEAR & DIFFERENTIAL HEIGHT ADJUSTMENT

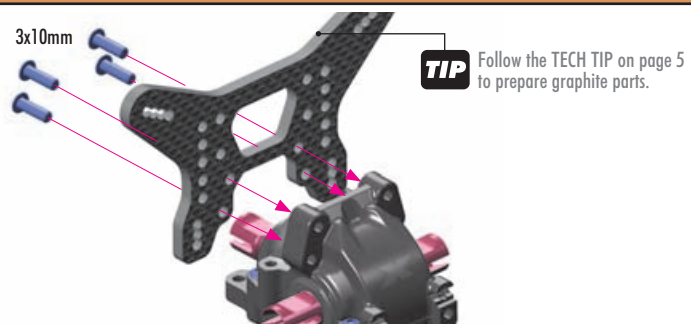
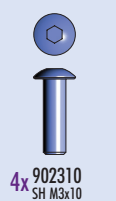
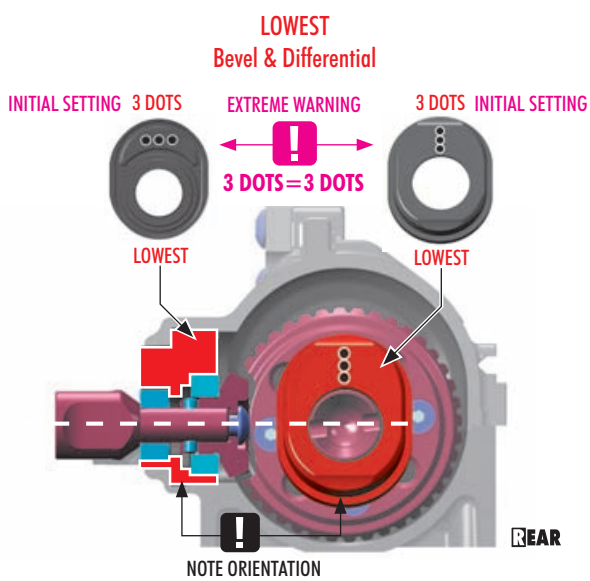

2. FRONT CENTRAL TRANSMISSION

CARPET **DIRT**

 **#365100**
OPTION XRAY XB4 ACTIVE DIFFERENTIAL
FRONT/REAR - SET



ACTIVE DIFF SEGMENTS

#325123	60°		OPTION
#325125	90°		INCLUDED
#325127	120°		OPTION

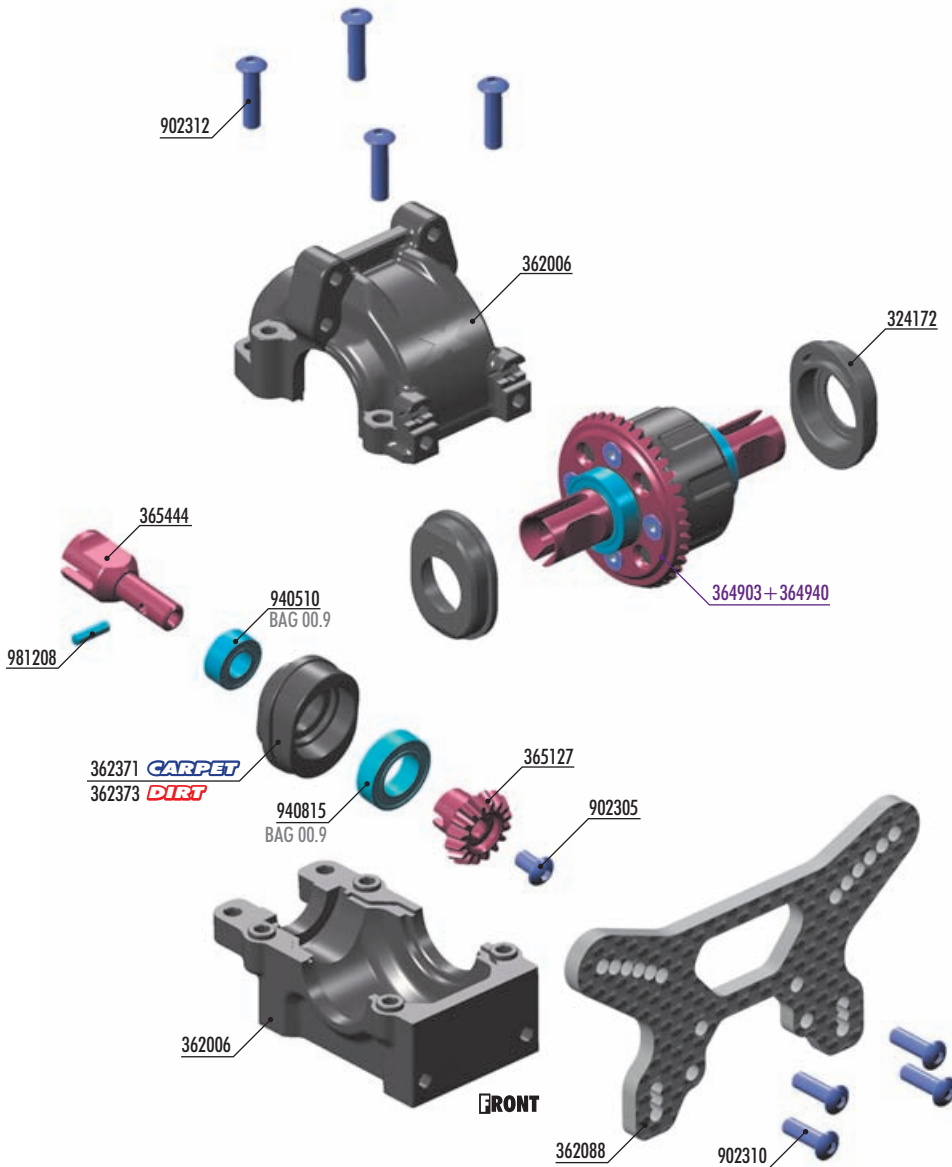

 **BALL-BEARING HUBS**
OPTION

#324172	1 DOT	INCLUDED	
#324172	2 DOTS	OPTION	
#324172	3 DOTS	INCLUDED	

 **ANGLE HUBS - FRONT**
OPTION

#362371	1 DOT	INCLUDED	
#362372	2 DOTS	OPTION	
#362373	3 DOTS	INCLUDED	

 **XRAY BALL-BEARINGS**
OPTION

#359050	5x10x4	GREASE	OPTION
#940510	5x10x4	OIL	INCLUDED
#940814	8x14x4	GREASE	OPTION
#940815	8x14x4	OIL	INCLUDED

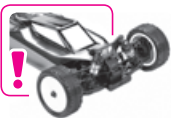

BAG

02.2

324172 COMPOSITE ADJUSTMENT BALL-BEARING HUB (2)
362006 DIFF BULKHEAD BLOCK SET
362088 GRAPHITE SHOCK TOWER FOR HS BULKHEAD - FRONT - 3.5MM - WIDER
365127 STEEL BEVEL DRIVE GEAR - FOR HS BULKHEAD - CNC-MACHINED - 16T
365444 CENTRAL DOGBONE SHAFT UNIVERSAL JOINT - HUDY SPRING STEEL™

902305 HEX SCREW SH M3x5 (10)
902310 HEX SCREW SH M3x10 (10)
902312 HEX SCREW SH M3x12 (10)
940510 BALL-BEARING 5x10x4 RUBBER SEALED - OIL (2)
940815 BALL-BEARING 8x14x4 RUBBER SEALED - OIL (2)
981208 PIN 2x8 (10)

364903 GEAR DIFFERENTIAL - LARGE VOLUME - SET
364940 STEEL DIFFERENTIAL BEVEL GEAR FOR LARGE VOLUME DIFF 40T

CARPET

362371 ANGLED HUB FOR BEVEL DRIVE GEAR - FRONT HS BULKHEAD - 1 DOT

DIRT

362373 ANGLED HUB FOR BEVEL DRIVE GEAR - FRONT HS BULKHEAD - 3 DOTS



1x 902305 SH M3x5



1x 940510 BB 5x10x4



1x 940815 BB 8x14x4

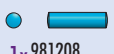

1x 981208 P 2x8

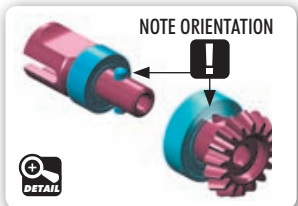
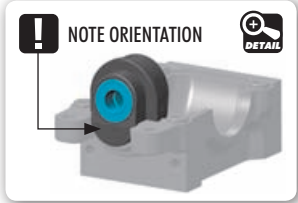
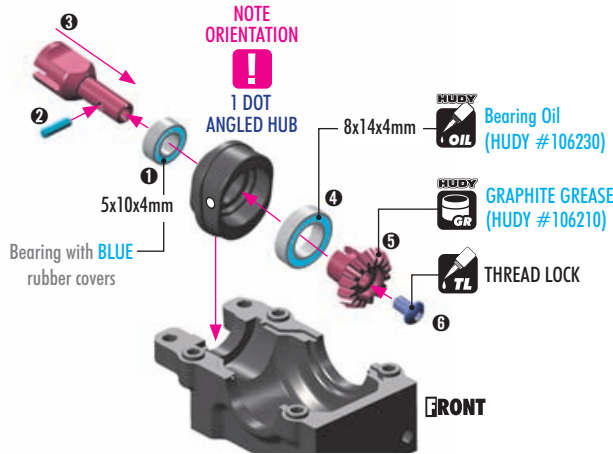
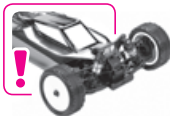

FRONT BEVEL DRIVE GEAR & DIFFERENTIAL HEIGHT ADJUSTMENT

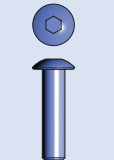
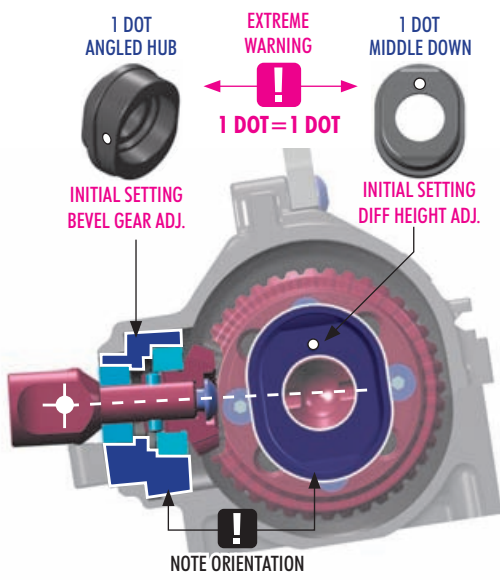

4x 902312 SH M3x12

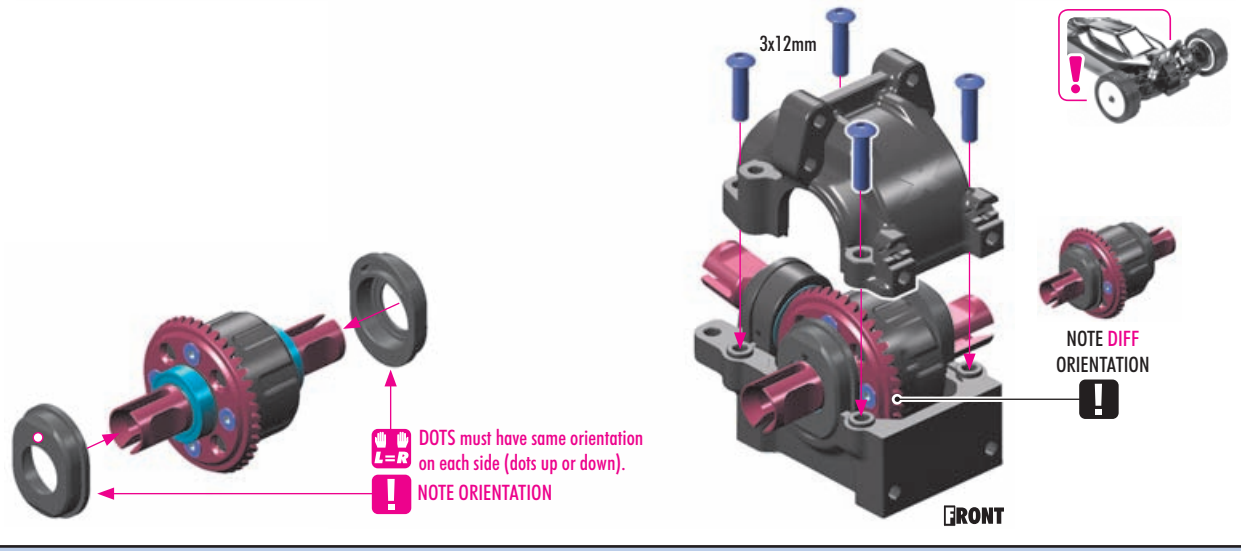

L=R DOTS must have same orientation on each side (dots up or down).
NOTE ORIENTATION

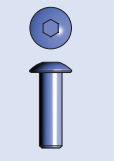

4x 902310 SH M3x10

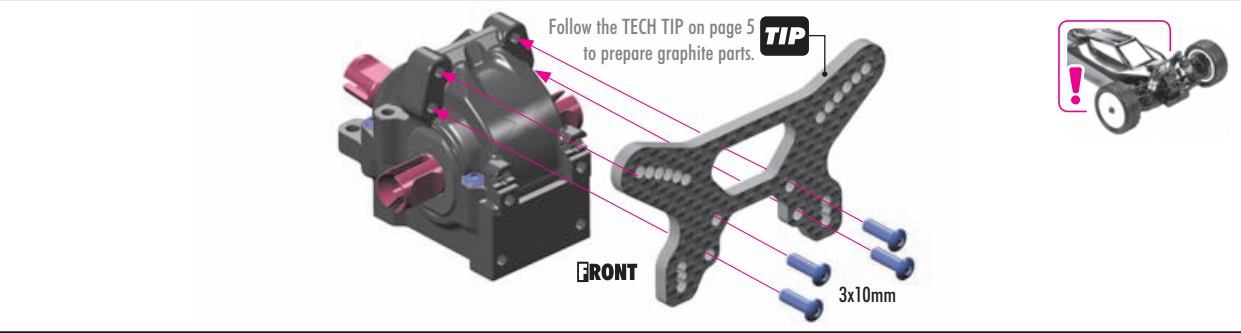

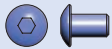

1x 902305
SH M3x5



1x 940510
BB 5x10x4



1x 940815
BB 8x14x4



1x 981208
P 2x8

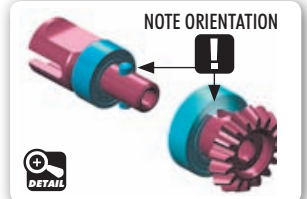
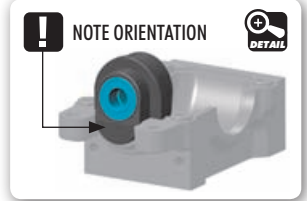
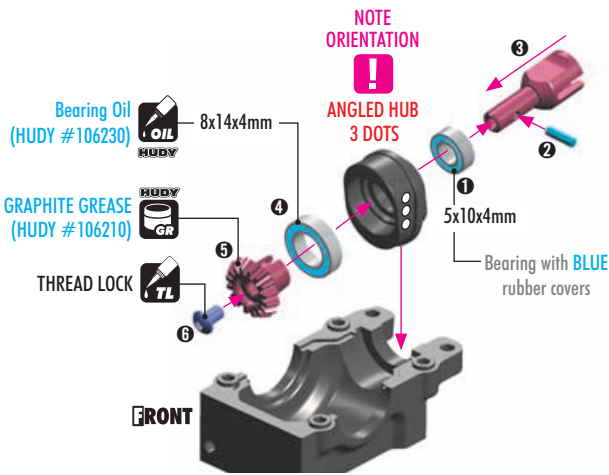
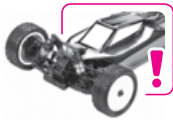

DIRT

FRONT BEVEL DRIVE GEAR & DIFFERENTIAL HEIGHT ADJUSTMENT

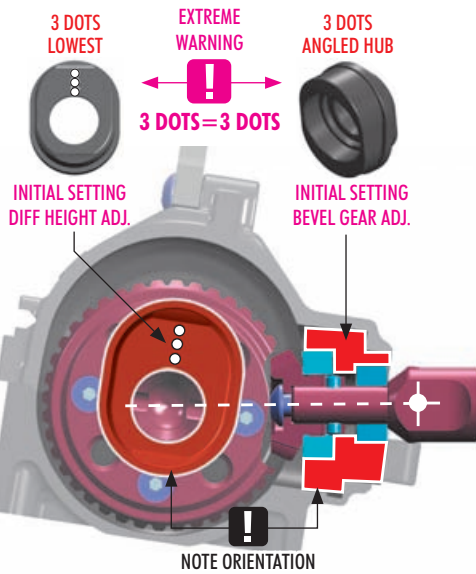

1x 902312
SH M3x12

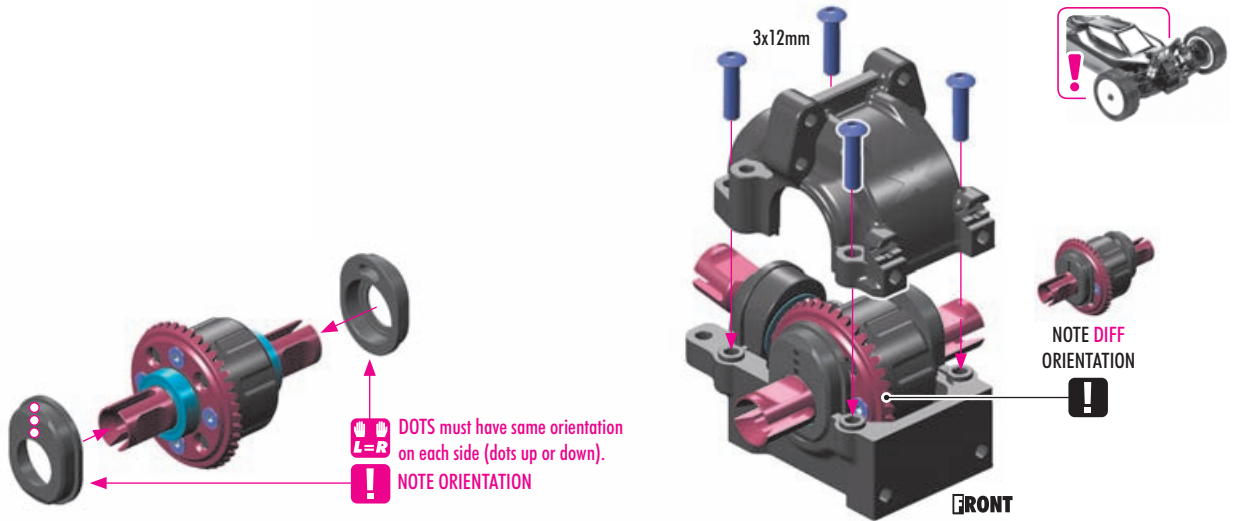

1x 902310
SH M3x10

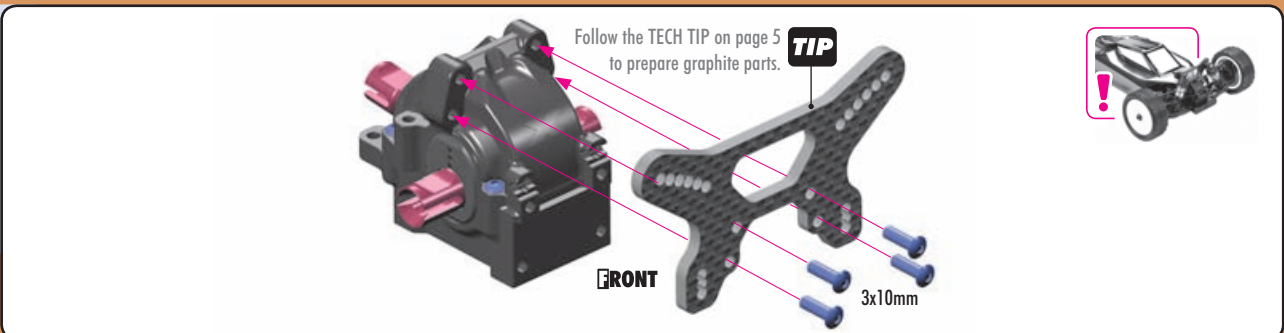

3. REAR SUSPENSION

REAR 903312, 363325, 362315, 48mm, 367210

LEFT 363123-M (LONG)

RIGHT 363113-M (LONG), 363113-M, 363123-M, 362315, 363316, 903312

902308, 362006, 362478 **CARPET DIRT**, 362473 **DIRT**

901304, 901303, 303431-K, 303454, 303454, 901308

OPTION #363317 ALU LOWER SUSPENS. HOLDER WIDE FOR HS BULKHEAD - RF

OPTION #363326 ALU LOWER SUSPENSION HOLDER WIDE FOR HS BULKHEAD - RR

Remove the 3x6.5x2mm shim from each rear arm.

OPTION	ANTI-ROLL BARS	THICKNESS	STATUS
	#362470	1.0mm	OPTION
	#362471	1.1mm	OPTION
	#362472	1.2mm	OPTION
	#362473	1.3mm	INCLUDED
	#362474	1.4mm	OPTION
	#362476	1.6mm	OPTION
	#362478	1.8mm	INCLUDED
	#362478	1.8mm	INCLUDED
	#362480	2.0mm	OPTION

OPTION	SHORT REAR SUSPENSION ARMS			
	#363112-M	RIGHT	MEDIUM	OPTION
	#363122-M	LEFT	MEDIUM	OPTION
	#363112-H	RIGHT	HARD	OPTION
	#363122-H	LEFT	HARD	OPTION
	#363112-G	RIGHT	GRAPHITE	OPTION
	#363122-G	LEFT	GRAPHITE	OPTION

OPTION	LONG REAR SUSPENSION ARMS			
	#363113-M	RIGHT	MEDIUM	INCLUDED
	#363123-M	LEFT	MEDIUM	INCLUDED
	#363113-H	RIGHT	HARD	OPTION
	#363123-H	LEFT	HARD	OPTION
	#363113-G	RIGHT	GRAPHITE	OPTION
	#363123-G	LEFT	GRAPHITE	OPTION



BAG

03

- 303431-K ALU 4.9MM BALL END - BLACK (2)
- 303454 BALL JOINT 4.9MM - OPEN (4)
- 362006 DIFF BULKHEAD BLOCK SET
- 362315 ECCENTRIC BUSHING SET (2)
- 363113-M COMPOSITE LONG SUSPENSION ARM REAR LOWER RIGHT - MEDIUM
- 363123-M COMPOSITE LONG SUSPENSION ARM REAR LOWER LEFT - MEDIUM
- 363316 ALU SUSPENSION HOLDER FOR HS BULKHEAD - REAR-FRONT
- 363325 ALU SUSPENSION HOLDER 2° FOR HS BULKHEAD - REAR-REAR
- 367210 SUSPENSION PIVOT PIN (2)

- 901303 HEX SCREW SB M3x3 (10)
- 901304 HEX SCREW SB M3x4 (10)
- 901308 HEX SCREW SB M3x8 (10)
- 902308 HEX SCREW SH M3x8 (10)
- 903312 HEX SCREW SFH M3x12 (10)

DIRT

- 362473 ANTI-ROLL BAR 1.3mm
- 362478 ANTI-ROLL BAR 1.8mm

CARPET

- 362478 ANTI-ROLL BAR 1.8mm

- 10**
- 2x From Rear Arm SHIM 3x6.5x2
- 4x 903312 SFH M3x12

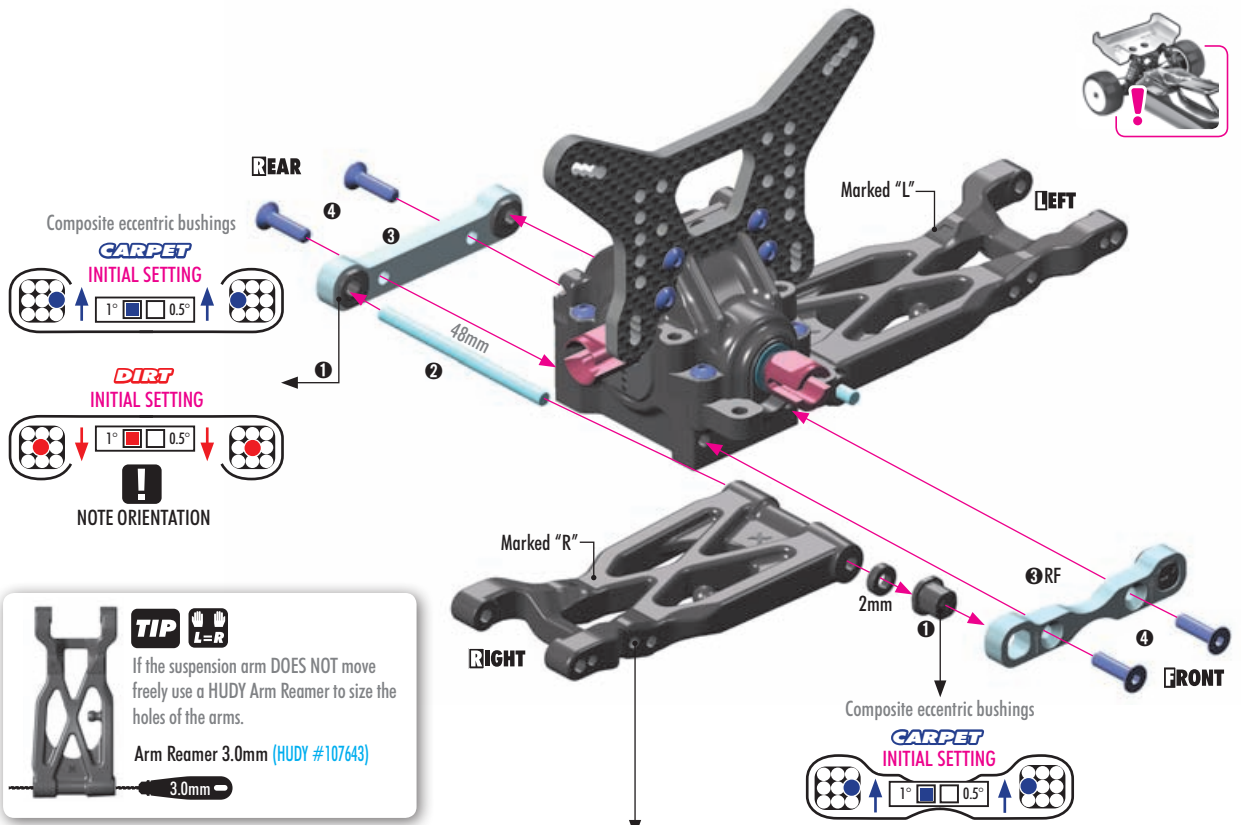

TIP If the suspension arm DOES NOT move freely use a HUDY Arm Reamer to size the holes of the arms.
Arm Reamer 3.0mm (HUDY #107643)

SHORT REAR SUSPENSION ARMS

OPTION	Part #	Side	Material	Option
	#363112-M	RIGHT	MEDIUM	OPTION
	#363122-M	LEFT	MEDIUM	OPTION
	#363112-H	RIGHT	HARD	OPTION
	#363122-H	LEFT	HARD	OPTION
	#363112-G	RIGHT	GRAPHITE	OPTION
	#363122-G	LEFT	GRAPHITE	OPTION

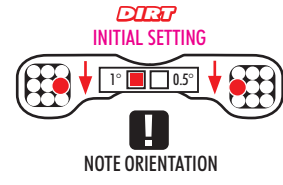
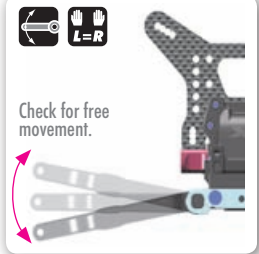

SET-UP BOOK
TOE-IN
ANTI-SQUAT
ROLL CENTER
TRACK-WIDTH

LONG REAR SUSPENSION ARMS

OPTION	Part #	Side	Material	Included
	#363113-M	RIGHT	MEDIUM	INCLUDED
	#363123-M	LEFT	MEDIUM	INCLUDED
	#363113-H	RIGHT	HARD	OPTION
	#363123-H	LEFT	HARD	OPTION
	#363113-G	RIGHT	GRAPHITE	OPTION
	#363123-G	LEFT	GRAPHITE	OPTION



ECCENTRIC BUSHINGS HAVE TWO DIFFERENT OFFSETS FROM THE CENTER.



The XRAY rear alu lower suspension holders provide great range of adjustment for the rear suspension. Using different combinations of eccentric bushings, fine adjustment of rear anti-squat, rear toe-in, rear roll center, and rear track-width can be obtained. For more information about the influence of rear anti-squat, rear toe-in, rear roll center and rear track width on car handling, please refer to HUDY Set-up Book (#209100).

ANTI-SQUAT

RR	RF	(°)
		=2°
		=3°
		=1°
		=3°
		=2°
		=4°
		=1°
		=2°
		=0°

ROLL CENTER

RR	RF	(mm)
		=+0.75mm
		=0mm
		=-0.75mm

TRACK-WIDTH

RR	RF	(mm)
		=+1.5mm
		=0mm
		=-1.5mm

The track-width is directly influenced by the size of the wheels and tires used.

The tables describe the amounts of adjustment using the center and outside positions of the eccentric bushings. The middle position eccentric bushings allow for finer adjustment increments.

TOE-IN

RR	RF	(°)
		=2°
		=3°
		=1°
		=3°
		=1°
		=2°
		=0°
		=3°
		=4°
		=2°

- 2x 901308 SB M3x8

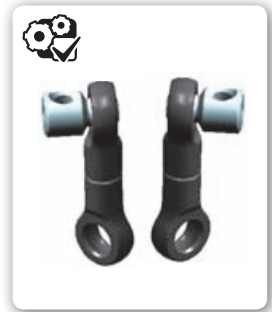
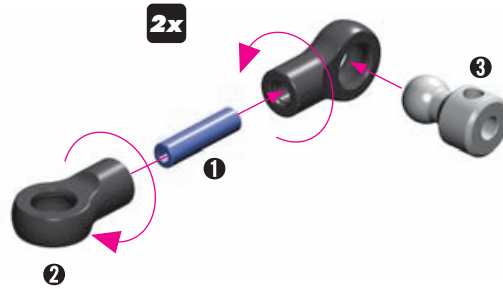
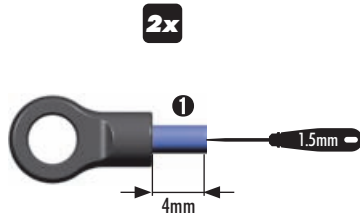

- 2x 901303 SB M3x3
- 2x 901304 SB M3x4
- 2x 902308 SH M3x8

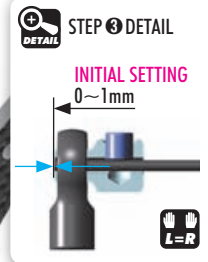

OPTION	ANTI-ROLL BARS	OPTION
#362470	1.0mm	OPTION
#362471	1.1mm	OPTION
#362472	1.2mm	OPTION
#362473	1.3mm	INCLUDED
#362474	1.4mm	OPTION
#362476	1.6mm	OPTION
#362478	1.8mm	INCLUDED
#362478	1.8mm	INCLUDED
#362480	2.0mm	OPTION

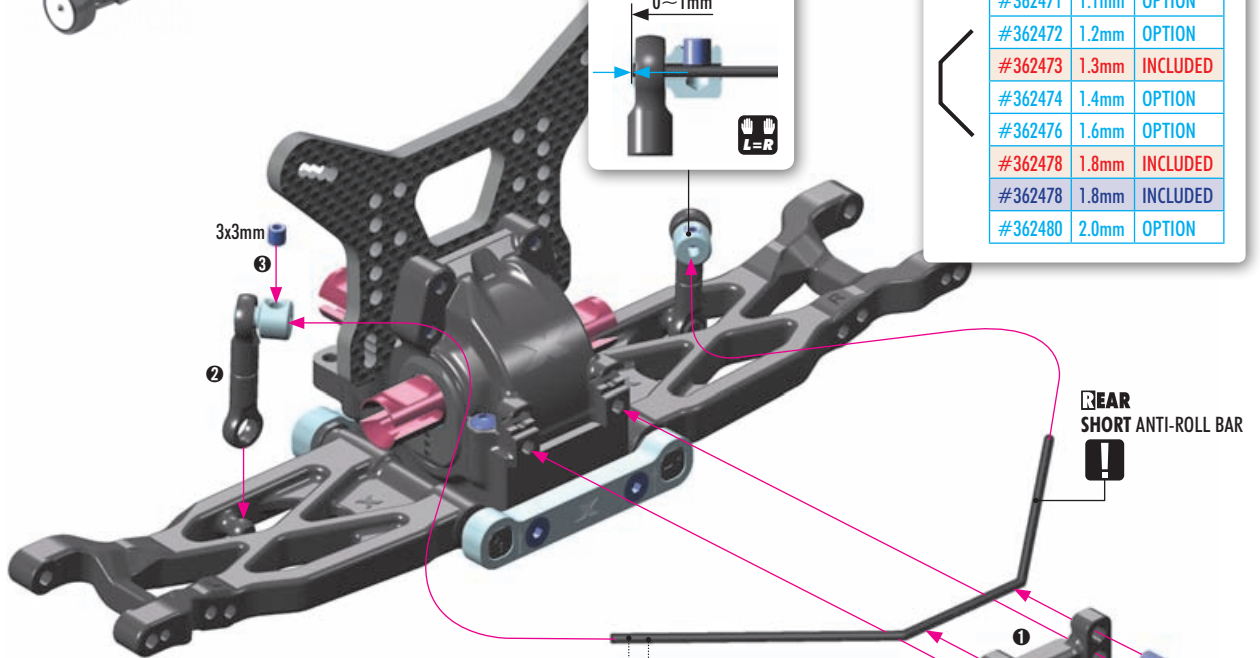

REAR ANTI-ROLL BAR

We recommend for these types of surfaces and traction levels:

DIRT
1.3mm for DIRT low & high traction

1.8mm for ASTRO

CARPET
1.8mm for CARPET & ASTRO

! In case the anti-roll bar wire is long and will touch the shock absorber then you have to cut approximately 3mm from each end of the wire.

CUT approx. 3mm

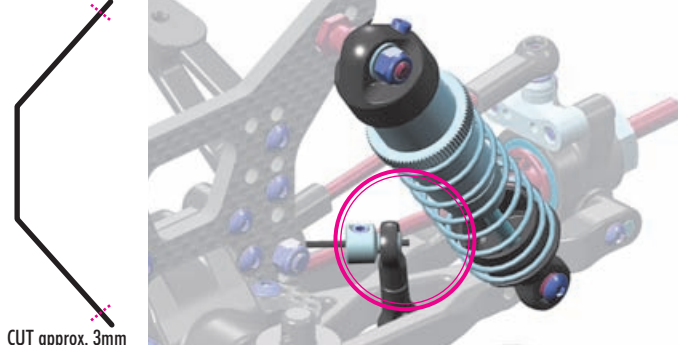

CUT approx. 3mm

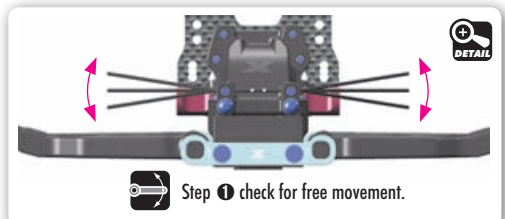
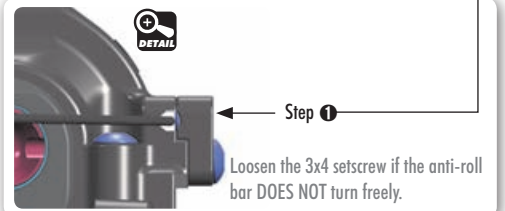

SET-UP BOOK

ANTI-ROLL BAR

3. FRONT SUSPENSION

CARPET DIRT

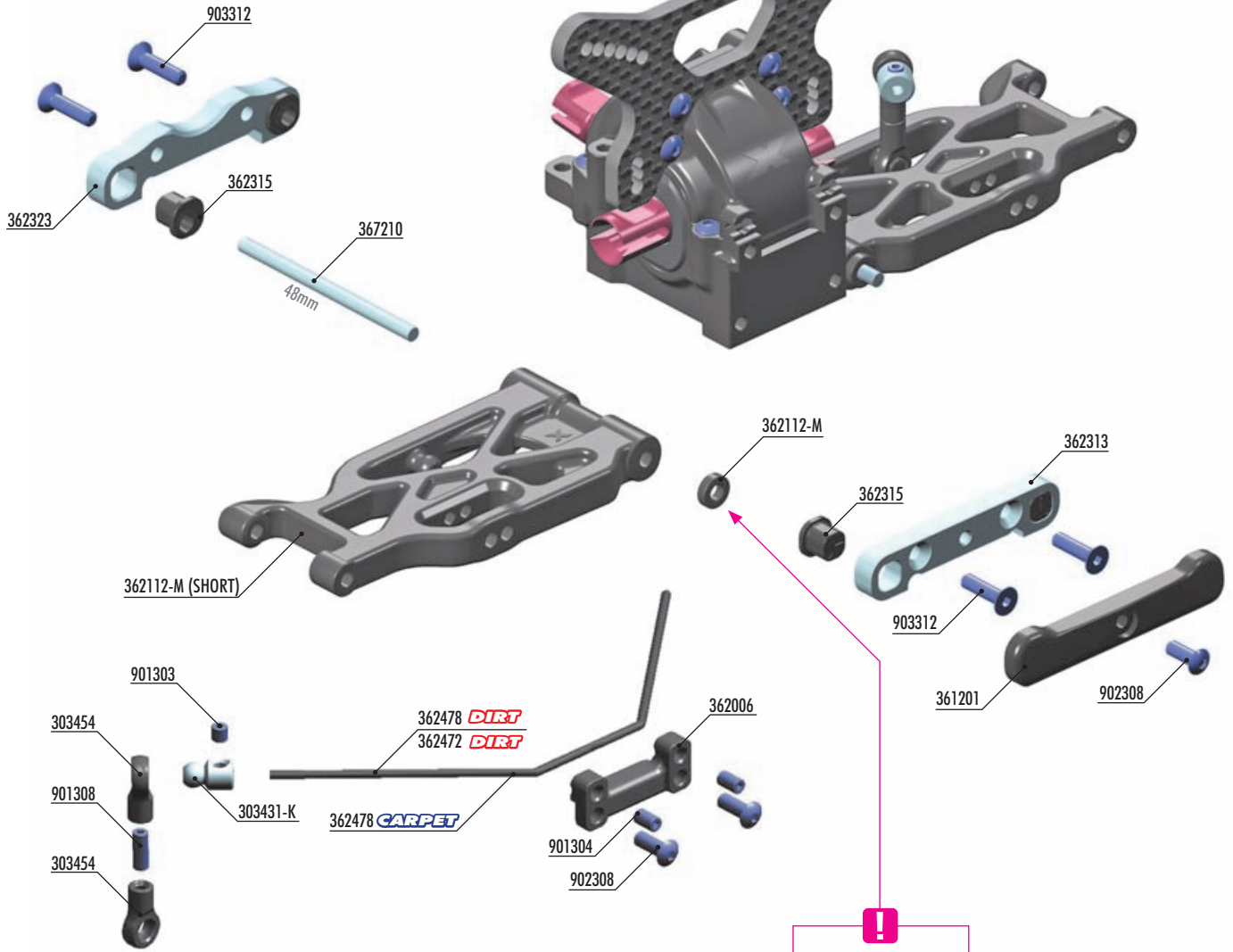
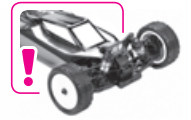

Remove the 3x6.5x2mm shim from each front arm.



ANTI-ROLL BARS			
#362470	1.0mm	OPTION	
#362471	1.1mm	OPTION	
#362472	1.2mm	INCLUDED	
#362473	1.3mm	OPTION	
#362474	1.4mm	OPTION	
#362476	1.6mm	OPTION	
#362478	1.8mm	INCLUDED	
#362478	1.8mm	INCLUDED	
#362480	2.0mm	OPTION	

SHORT FRONT SUSPENSION ARMS			
#362112	MEDIUM	INCLUDED	
#362112-H	HARD	OPTION	
#362112-G	GRAPHITE	OPTION	

LONG FRONT SUSPENSION ARMS			
#362113-H	HARD	OPTION	
#362113-G	GRAPHITE	OPTION	



- 303431-K ALU 4.9MM BALL END - BLACK (2)
- 303454 BALL JOINT 4.9MM - OPEN (4)
- 361201 COMPOSITE FRONT BUMPER - ONE HOLE
- 362006 DIFF BULKHEAD - HORIZONTAL SPLIT DESIGN (HS) - FRONT/REAR - SET
- 362112-M COMPOSITE SUSPENSION ARM FRONT LOWER - MEDIUM
- 362313 ALU LOWER SUSP. HOLDER FOR HS BULKHEAD - FRONT-FRONT
- 362315 ECCENTRIC BUSHING SET (2)
- 362323 ALU LOWER SUSP. HOLDER FOR HS BULKHEAD - FRONT-REAR
- 367210 SUSPENSION PIVOT PIN (2)

- 901303 HEX SCREW SB M3x3 (10)
- 901304 HEX SCREW SB M3x4 (10)
- 901308 HEX SCREW SB M3x8 (10)
- 902308 HEX SCREW SH M3x8 (10)
- 903312 HEX SCREW SFH M3x12 (10)

- DIRT**
- 362473 ANTI-ROLL BAR 1.3mm
 - 362478 ANTI-ROLL BAR 1.8mm
- CARPET**
- 362478 ANTI-ROLL BAR 1.8mm

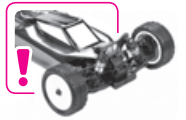

- 10** From Front Arm SHIM 3x6.5x2
- 4x** 903312 SFH M3x12

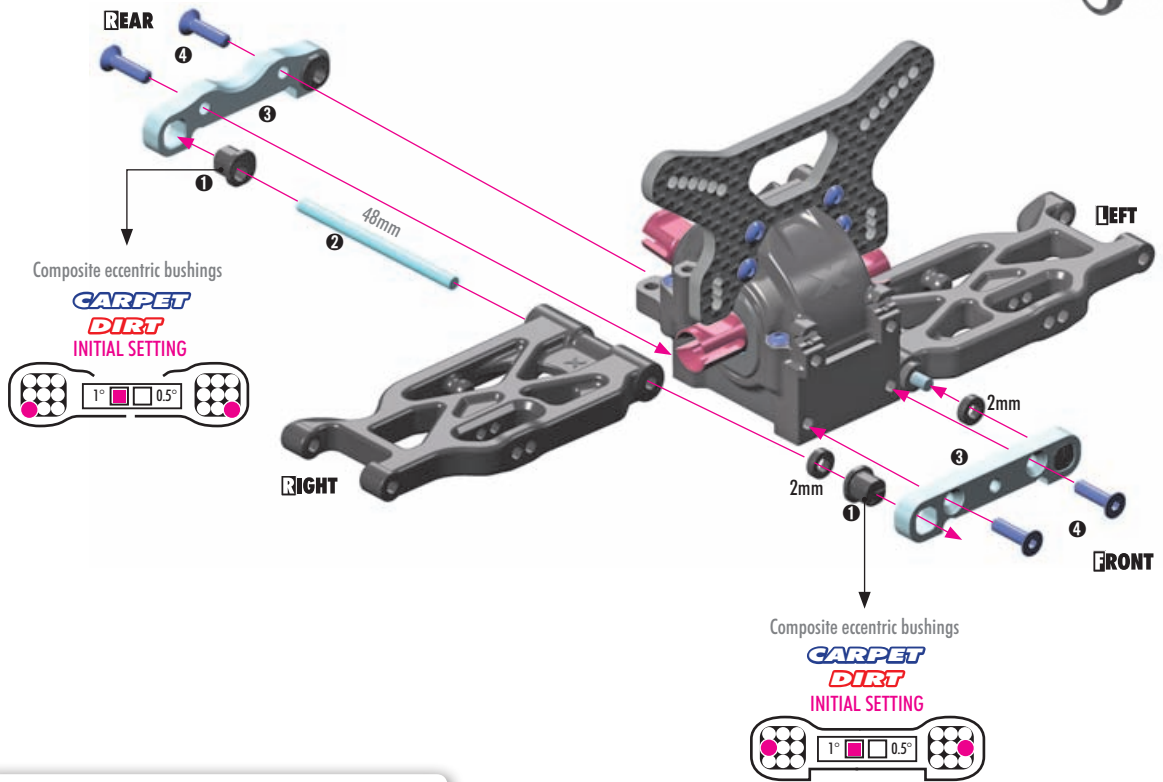

TIP If the suspension arm DOES NOT move freely use a HUDY Arm Reamer to size the holes of the arms.

Arm Reamer 3.0mm (HUDY #107643)

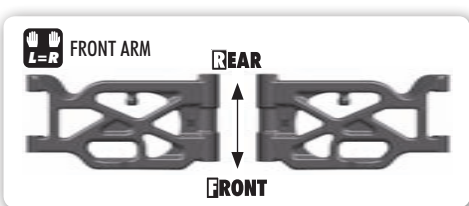

OPTION	SHORT FRONT SUSPENSION ARMS			
#362112	MEDIUM	INCLUDED		
#362112-H	HARD	OPTION		
#362112-G	GRAPHITE	OPTION		
OPTION	LONG FRONT SUSPENSION ARMS			
#362113-H	HARD	OPTION		
#362113-G	GRAPHITE	OPTION		

SET-UP BOOK
KICK UP
ROLL CENTER
TRACK-WIDTH

ECCENTRIC BUSHINGS HAVE TWO DIFFERENT OFFSETS FROM THE CENTER.



The XRAY alu front lower suspension holders provide great range of adjustment for the front suspension. Using different combinations of eccentric bushings, fine adjustment of front kick-up, roll-center, and front track-width can be obtained. For more information about the influence of kick-up, front track-width, and roll centers on car handling, please refer to HUDY Set-up Book (#209100).

KICK-UP			(°)
FF	FR		
			=7°
			=6°
			=8°
			=6°
			=5°
			=7°
			=8°
			=7°
			=9°

ROLL CENTER			(mm)
FF	FR		
			= +0.75mm
			= 0mm
			= -0.75mm

TRACK-WIDTH			(mm)
FF	FR		
			= +1.5mm
			= 0mm
			= -1.5mm

The tables describe the amounts of adjustment using the center and outside positions of the eccentric bushings. The middle position eccentric bushings allow for finer adjustment increments.

The track-width is directly influenced by the size of the wheels and tires used.

TOTAL CASTER=C-HUB CASTER+KICK UP						
C-HUB CASTER	KICK-UP					
	6°	7°	8°	9°	10°	
6°	12°	13°	14°	15°	16°	
9°	15°	16°	17°	18°	19°	

Caster is the angle between the steering pivot axis and the vertical plane. Caster is affected not only by the C-Hub caster, but also by the front kick-up angle relative to the flat chassis bottom. The table indicates how kick up angle effects total caster.

The XB4's stock caster blocks are 9°, but 6° blocks are available as an option.

3. FRONT SUSPENSION

CARPET DIRT



2x 901308
SB M3x8

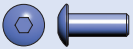
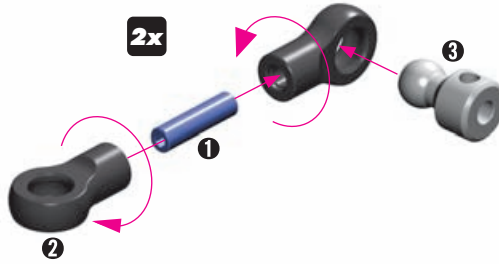
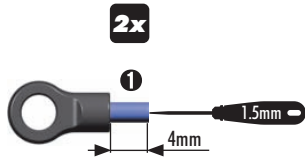

1x 902308
SH M3x8

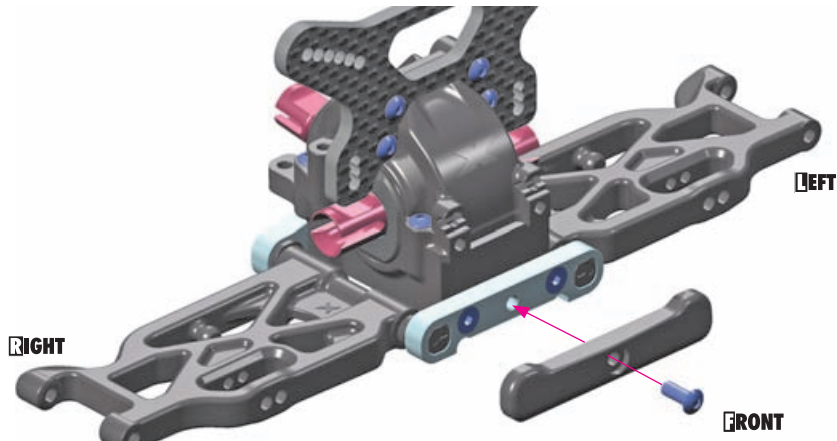

2x 901303
SB M3x3



2x 901304
SB M3x4



2x 902308
SH M3x8

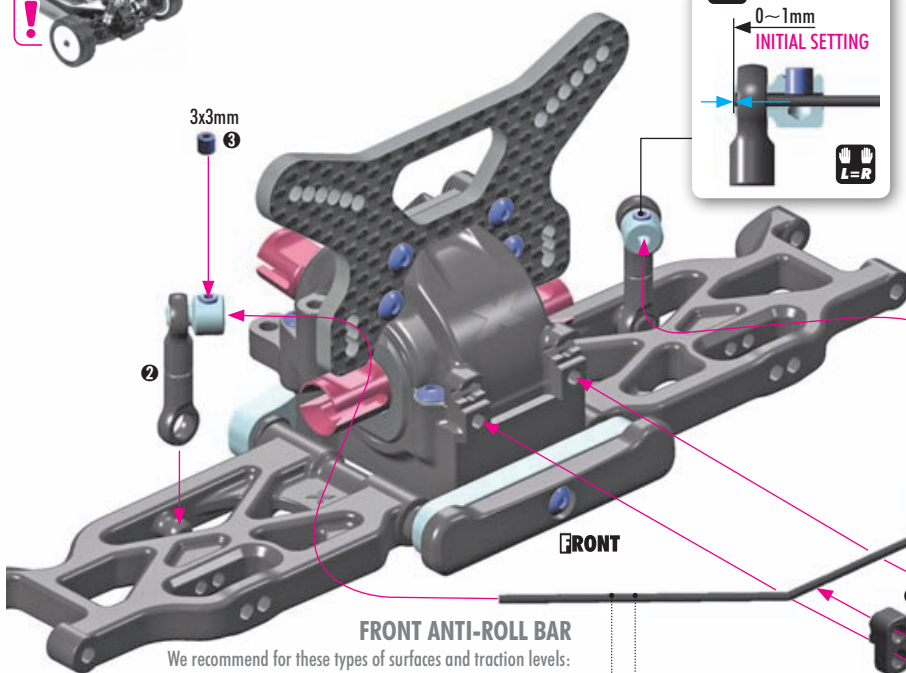
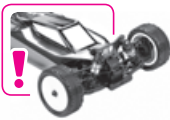

ANTI-ROLL BARS			
OPTION	THICKNESS	STATUS	
#362470	1.0mm	OPTION	
#362471	1.1mm	OPTION	
#362472	1.2mm	INCLUDED	
#362473	1.3mm	OPTION	
#362474	1.4mm	OPTION	
#362476	1.6mm	OPTION	
#362478	1.8mm	INCLUDED	
#362478	1.8mm	INCLUDED	
#362480	2.0mm	OPTION	

FRONT ANTI-ROLL BAR

We recommend for these types of surfaces and traction levels:

DIRT
1.2mm for DIRT low & high traction
1.8mm for ASTRO

CARPET
1.8mm for CARPET & ASTRO

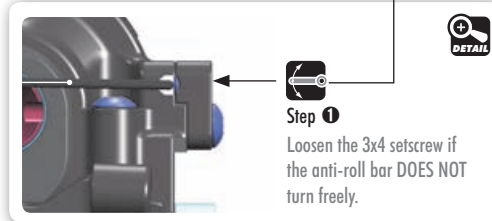
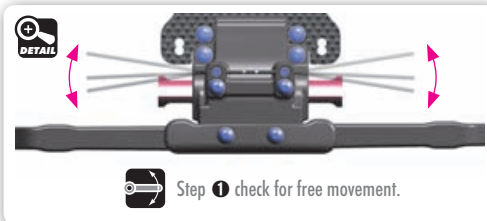

SET-UP BOOK

ANTI-ROLL BAR

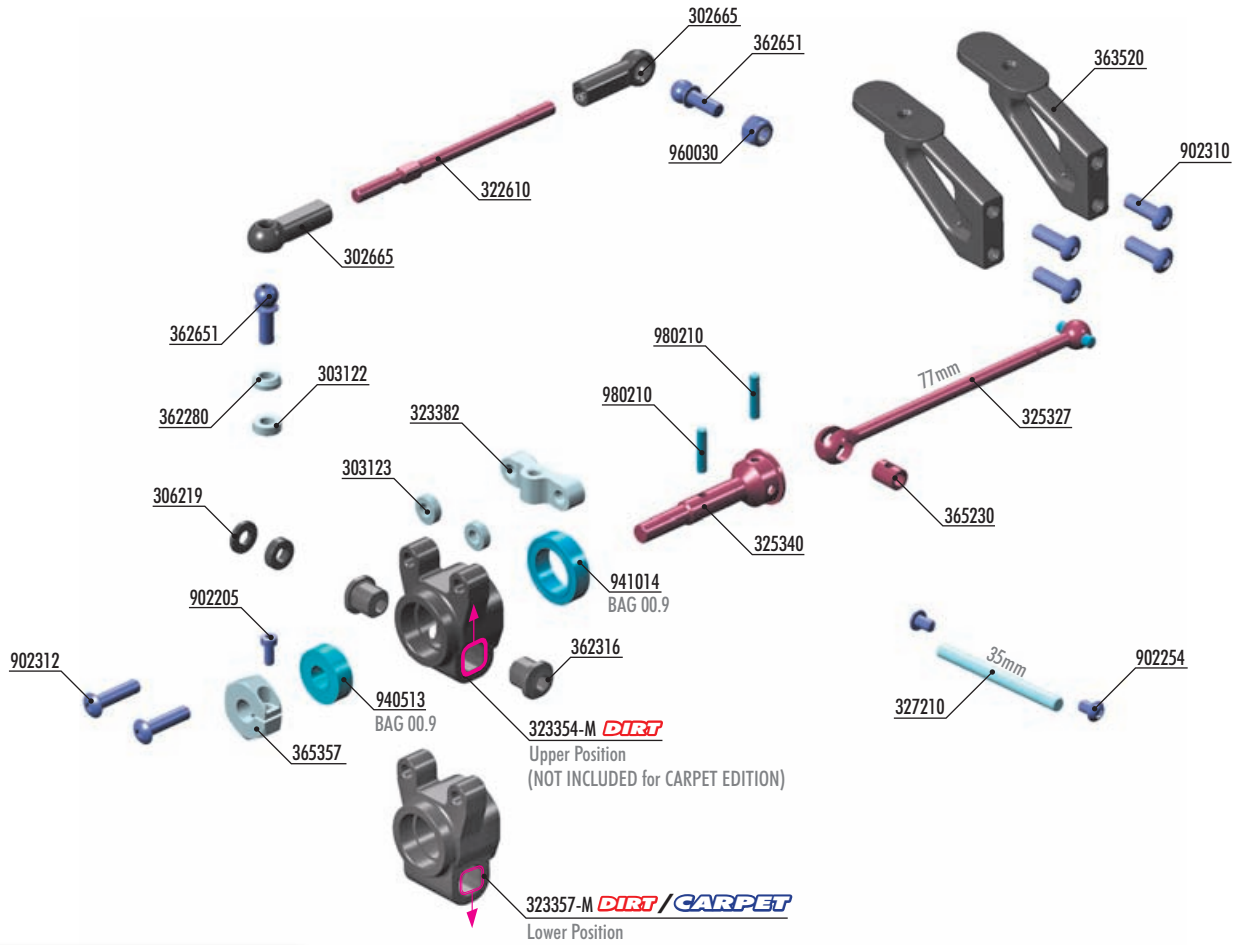

HUDY TITAN BALL ENDS
 #990008 8mm Thread OPTION

REAR UPRIGHTS

		Position	
#323354-M	MEDIUM	UPPER	INCLUDED
#323357-M	MEDIUM	LOWER	INCLUDED
#323357-M	MEDIUM	LOWER	INCLUDED
#323354-H	HARD	UPPER	OPTION
#323354-G	GRAPHITE	UPPER	OPTION
#323357-G	GRAPHITE	LOWER	OPTION
#323355	ALU HIGH	UPPER	OPTION
#323356	ALU LOW	LOWER	OPTION

#325341 REAR ADJ. DRIVE AXLE LB - HUDY SPRING STEEL™
#325390 ALU SHIM 10x12x2MM (2)

ALU CONICAL SHIMS

#362280	SILVER	INCLUDED
#362280-K	BLACK	OPTION
#362280-O	ORANGE	OPTION

WHEEL HUBS 12MM

#365360	+4.5mm - 6 SLOTS	OPTION
#365359	+3.75mm - 5 SLOTS	OPTION
#365358	+3.0mm - 4 SLOTS	OPTION
#365357	+2.25mm - 3 SLOTS	INCLUDED
#365356	+1.5mm - 2 SLOTS	OPTION
#365355	+0.75mm - 1 SLOT	OPTION
#365353	0mm - 0 SLOTS	OPTION
#365354	-0.75mm - Lightw.	OPTION
#365361	-1.25mm - Lightw.	OPTION

XRAY BALL-BEARINGS

#940512	5x12x4	OIL	OPTION
#941015	10x15x4	OIL	OPTION
#940513	5x12x4	GREASE	INCLUDED
#941014	10x15x4	GREASE	INCLUDED

ALU NUTS M3

#296530-B	BLUE	OPTION
#296530-K	BLACK	OPTION
#296530-O	ORANGE	OPTION
#960031	SILVER	OPTION



- 302665 COMPOSITE BALL JOINT 4.9MM - CLOSED WITH HOLE (4)
- 303122 ALU SHIM 3x6x1.0mm (10)
- 303123 ALU SHIM 3x6x2.0mm (10)
- 306219 COMPOSITE SET OF SERVO SHIMS (4)
- 322610 ADJ. TURNBUCKLE M3 L/R 55 MM - SPRING STEEL (2)
- 323354-M COMPOSITE UPRIGHT REAR - UPPER POSITION - MEDIUM
- 323357-M COMPOSITE UPRIGHT REAR - LOWER POSITION - MEDIUM
- 323382 ALU REAR HUB PLATE FOR MULTI ADJ. UPRIGHT - 1-HOLE
- 325327 REAR DRIVE SHAFT 77MM WITH 2.5MM PIN - SPRING STEEL™
- 325340 REAR DRIVE AXLE LB - HUDY SPRING STEEL™
- 327210 FRONT SUSPENSION PIVOT PIN (2)
- 362280 ALU CONICAL SHIM 3x6x2.0MM (10)
- 362316 OPEN ECCENTRIC BUSHING SET (2)

- 362651 BALL END 4.9MM WITH THREAD 8MM (2)
- 363520 REAR WING POST - V2 (2)
- 365230 DRIVE SHAFT COUPLING - HUDY SPRING STEEL™
- 365357 ALU WHEEL HUB 12MM - OFFSET "+2.25MM" (2)
- 902205 HEX SCREW SH M2x5 (10)
- 902254 HEX SCREW SH M2.5x4 (10)
- 902310 HEX SCREW SH M3x10 (10)
- 902312 HEX SCREW SH M3x12 (10)
- 940513 BALL-BEARING 5x12x4 RUBBER SEALED - GREASE (2)
- 941014 BALL-BEARING 10x15x4 RUBBER SEALED - GREASE (2)
- 960030 NUT M3 (10)
- 980210 PIN 2x10 (10)

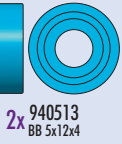
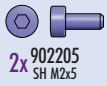

2x

UPRIGHT ALTERNATIVE 2
We recommend for these types of surfaces and traction:
• DIRT low & high traction
• Wet ASTRO

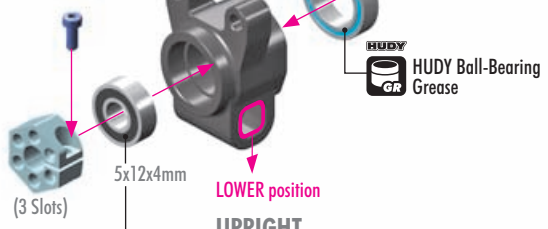
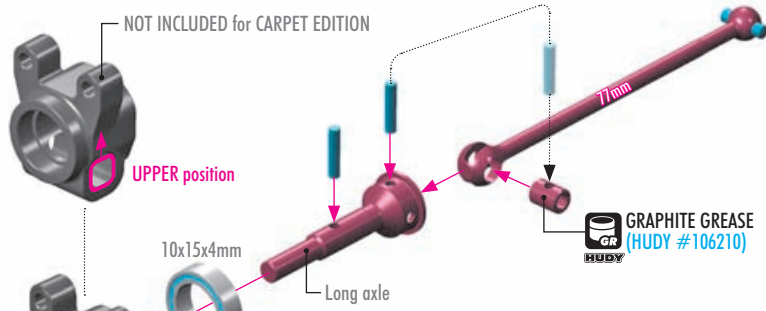

UPRIGHT ALTERNATIVE 1
We recommend for these types of surfaces and traction:
• CARPET
• Dry ASTRO
• DIRT very high traction

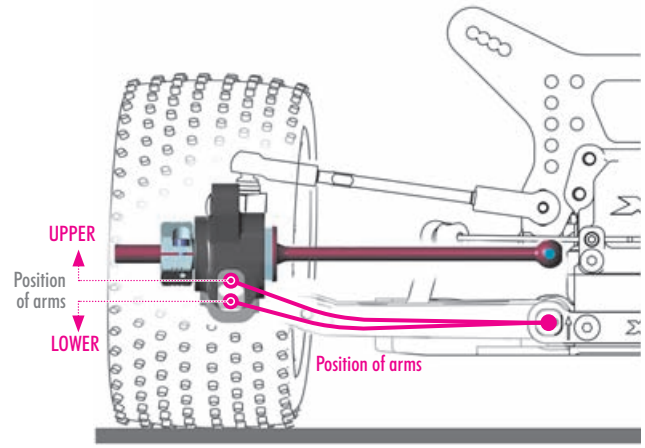

OPTION

#325341 REAR ADJ. DRIVE AXLE LB
#325390 ALU SHIM 10x12x2mm (2)

NOT INCLUDED for CARPET EDITION

GRAPHITE GREASE (HUDY #106210)

HUDY Ball-Bearing Grease

WHEEL HUBS 12MM

OPTION	Part #	Offset	Slots	Availability
	#365360	+4.5mm	- 6 SLOTS	OPTION
	#365359	+3.75mm	- 5 SLOTS	OPTION
	#365358	+3.0mm	- 4 SLOTS	OPTION
	#365357	+2.25mm	- 3 SLOTS	INCLUDED
	#365356	+1.5mm	- 2 SLOTS	OPTION
	#365355	+0.75mm	- 1 SLOT	OPTION
	#365353	0mm	- 0 SLOTS	OPTION
	#365354	-0.75mm	- Lightw.	OPTION
	#365361	-1.25mm	- Lightw.	OPTION

OPTIONAL HEX HUB EFFECTS

Different offset hex hubs are used to increase or decrease the track-width.

LESS OFFSET	MORE OFFSET
Rear - more traction	Rear - less traction
Front - more steering	Front - less steering

XRAY BALL-BEARINGS

OPTION	Part #	Size	Lubricant	Availability
	#940512	5x12x4	OIL	OPTION
	#941015	10x15x4	OIL	OPTION
	#940513	5x12x4	GREASE	INCLUDED
	#941014	10x15x4	GREASE	INCLUDED

REAR UPRIGHTS

OPTION	Part #	Material	Position	Availability
	#323354-M	MEDIUM	UPPER	INCLUDED
	#323357-M	MEDIUM	LOWER	INCLUDED
	#323357-M	MEDIUM	LOWER	INCLUDED
	#323354-H	HARD	UPPER	OPTION
	#323354-G	GRAPHITE	UPPER	OPTION
	#323357-G	GRAPHITE	LOWER	OPTION
	#323355	ALU HIGH	UPPER	OPTION
	#323356	ALU LOW	LOWER	OPTION

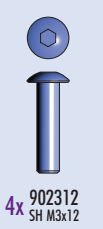

2x

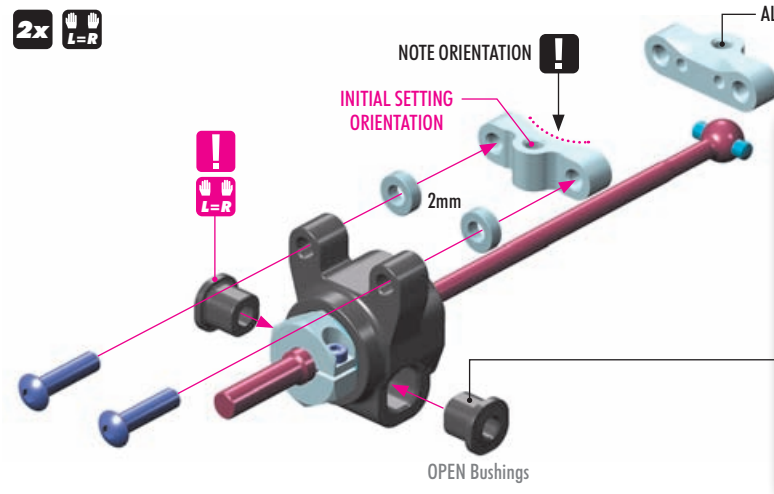

ALTERNATIVE ORIENTATION

NOTE ORIENTATION

INITIAL SETTING ORIENTATION

UPRIGHT LOWER position

UPRIGHT UPPER position

INITIAL SETTING

- CARPET
- ASTRO
- DIRT very high traction

INITIAL SETTING

- DIRT low & high traction
- WET ASTRO

IO
2x 306219 SHIM 3x6x1

IO
2x 306219 SHIM 3x6x2

IO
4x 902254 SH M2.5x4

TIP Ensure that the rear upright moves freely. If it DOES NOT move freely, use sandpaper to thin both wheelbase adjustment shims.

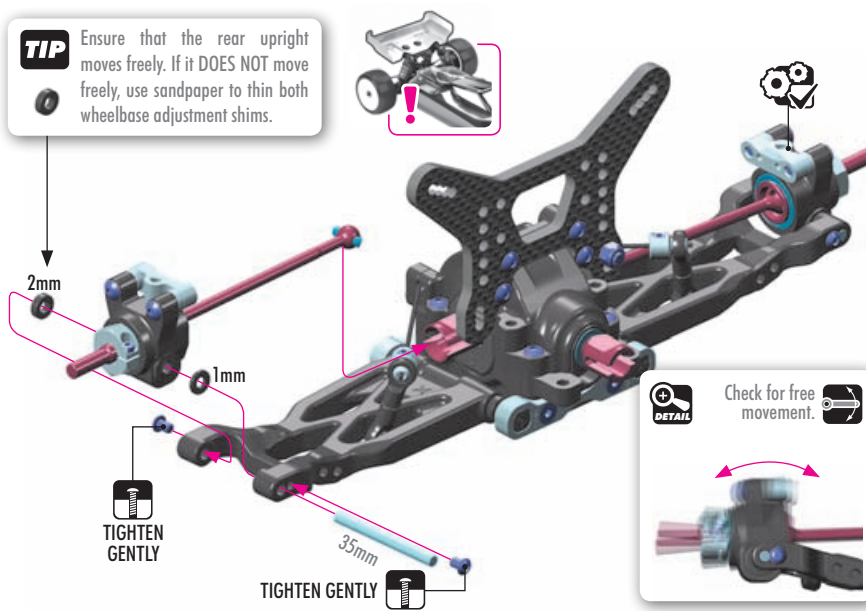

LONGER WHEELBASE

Adjustment Shim IN FRONT OF HUB moves hub rearward.



SHORTER WHEELBASE

Adjustment Shim BEHIND HUB moves hub forward.

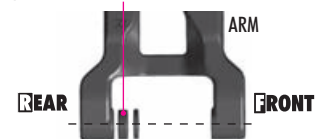

SET-UP BOOK

WHEELBASE

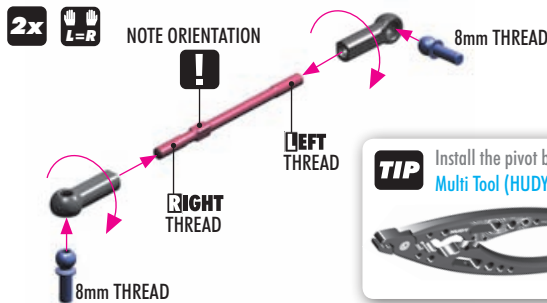

TIP Install the pivot balls with Professional Multi Tool (HUDY #183011).



OPTION	HUDY TITAN BALL ENDS	OPTION
#990008	8mm Thread	OPTION

SET-UP BOOK

CAMBER

IO
2x 303122 SHIM 3x6x1

IO
2x 362280 CON. SHIM 3x6x2

IO
2x 960030 N M3

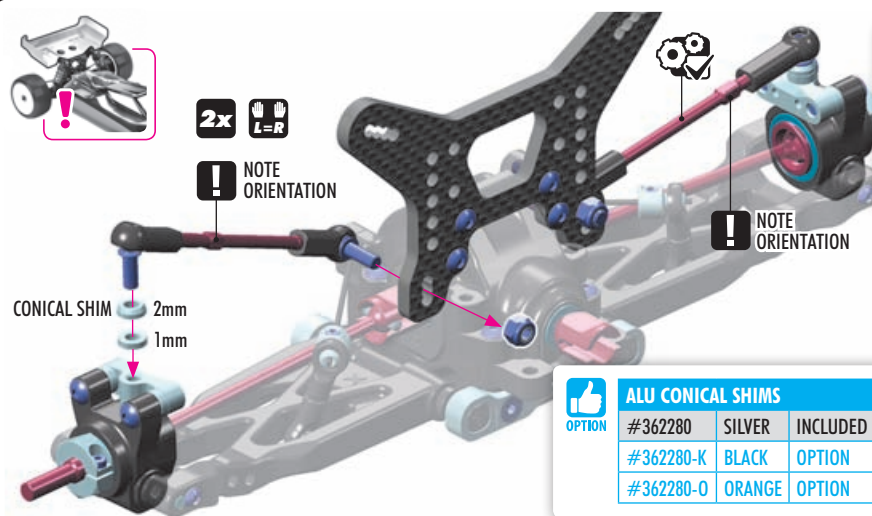

OPTION	ALU NUTS M3	
#296530-B	BLUE	OPTION
#296530-K	BLACK	OPTION
#296530-O	ORANGE	OPTION
#960031	SILVER	OPTION

OPTION	ALU CONICAL SHIMS	
#362280	SILVER	INCLUDED
#362280-K	BLACK	OPTION
#362280-O	ORANGE	OPTION



SET-UP BOOK

ROLL CENTER

IO
4x 902310 SH M3x10

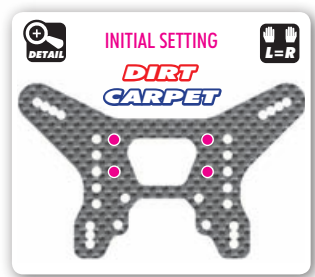
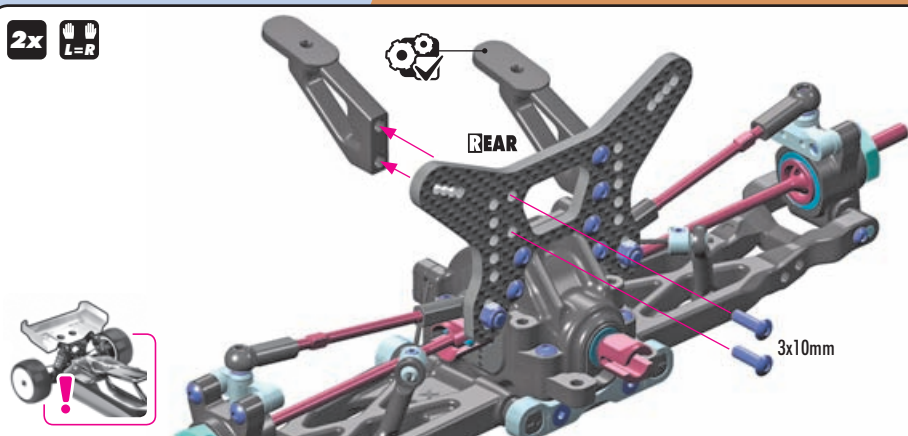



WHEEL HUBS 12MM			
#365360	+4.5mm	- 6 SLOTS	OPTION
#365359	+3.75mm	- 5 SLOTS	OPTION
#365358	+3.0mm	- 4 SLOTS	OPTION
#365357	+2.25mm	- 3 SLOTS	OPTION
#365356	+1.5mm	- 2 SLOTS	INCLUDED
#365355	+0.75mm	- 1 SLOT	OPTION
#365353	0mm	- 0 SLOTS	OPTION
#365354	-0.75mm	- Lightw.	OPTION
#365361	-1.25mm	- Lightw.	OPTION



XRAY BALL-BEARINGS			
#940510	5x10x4	OIL	OPTION
#940512	5x12x4	OIL	OPTION
#359050	5x10x4	GREASE	INCLUDED
#940513	5x12x4	GREASE	INCLUDED



HUDY TITAN BALL ENDS			
#990008	8mm	OPTION	
#990010	10mm	OPTION	



DRIVE SHAFT COLLARS		
#365470	COMPOSITE	INCLUDED
#365471-K	ALU - BLACK	OPTION
#365471-O	ALU - ORANGE	OPTION



STEERING BLOCKS		
#362250	MEDIUM	INCLUDED
#362250-H	HARD	OPTION
#362250-G	GRAPHITE	OPTION



C-HUBS		
#362210	RIGHT 9° - M	INCLUDED
#362210-H	RIGHT 9° - H	OPTION
#362210-G	RIGHT 9° - G	OPTION
#362211	RIGHT 6°	OPTION
#362234	ALU RIGHT 12°	OPTION
#362220	LEFT 9° - M	INCLUDED
#362220-H	LEFT 9° - H	OPTION
#362220-G	LEFT 9° - G	OPTION
#362221	LEFT 6°	OPTION
#362244	ALU LEFT 12°	OPTION



FRONT DRIVE SHAFTS (2.5mm PIN)			
#365202	ECS	83mm	OPTION
#365225	CVD	83mm	INCLUDED
#365226	CVD	84mm	OPTION

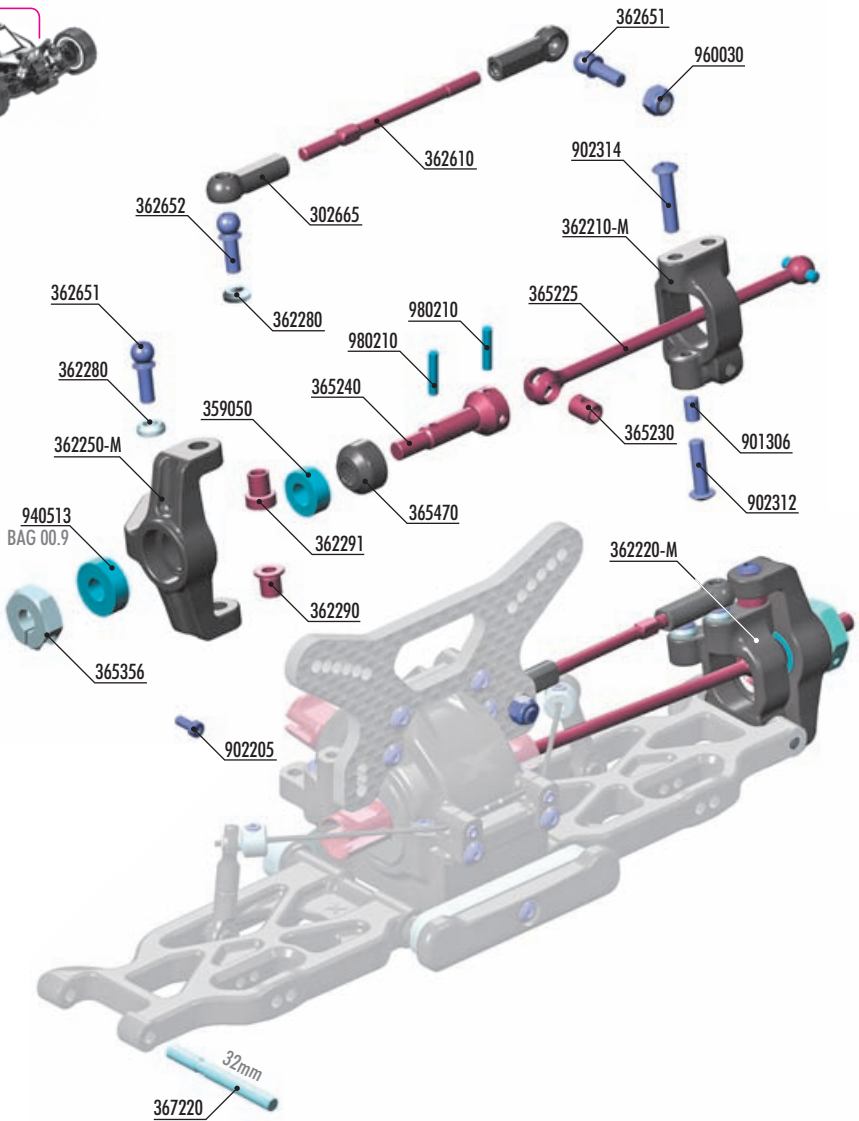

#360900 ALU STEERING BLOCKS & 7° C-HUBS - SET

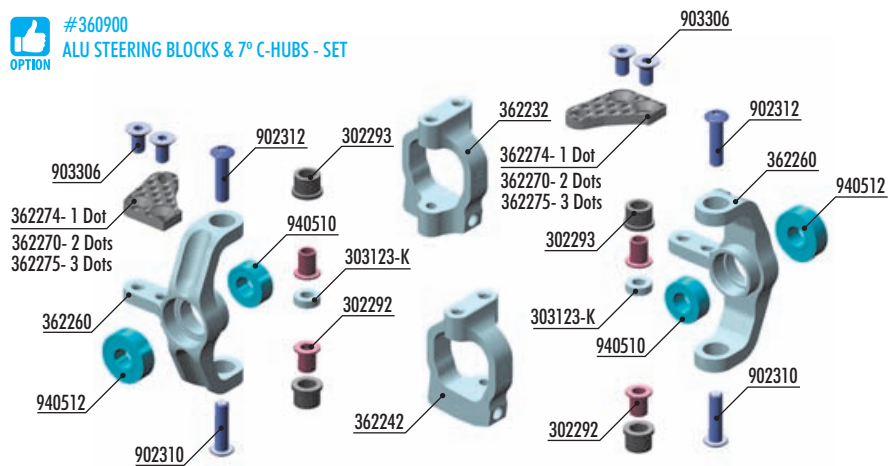

BAG



- 302665 COMPOSITE BALL JOINT 4.9MM - CLOSED WITH HOLE (4)
- 362210-M COMPOSITE C-HUB 9° DEG. RIGHT - MEDIUM
- 362220-M COMPOSITE C-HUB 9° DEG. LEFT - MEDIUM
- 362250-M COMPOSITE STEERING BLOCK - MEDIUM
- 362280 ALU CONICAL SHIM 3x6x2.0MM (10)
- 362290 STEEL STEERING BUSHING - SHORT (2)
- 362291 STEEL STEERING BUSHING - LONG (2)
- 362610 ADJ. TURNBUCKLE M3 L/R 50 MM - SPRING STEEL (2)
- 362651 BALL END 4.9MM WITH THREAD 8MM (2)
- 362652 BALL END 4.9MM WITH THREAD 10MM (2)
- 365225 FRONT DRIVE SHAFT 83MM WITH 2.5MM PIN - HUDY SPRING STEEL™
- 365230 DRIVE SHAFT COUPLING - HUDY SPRING STEEL™
- 365240 FRONT DRIVE AXLE - HUDY SPRING STEEL™

- 365356 ALU WHEEL HUB 12MM - OFFSET "+1.50MM" (2)
- 365470 COMPOSITE DRIVE SHAFT SAFETY COLLAR (3)
- 367220 FRONT ARM PIVOT PIN (2)
- 359050 BALL-BEARING 5x10x4 STEEL SEALED - GREASE (2)
- 901306 HEX SCREW SB M3x6 (10)
- 902205 HEX SCREW SH M2x5 (10)
- 902312 HEX SCREW SH M3x12 (10)
- 902314 HEX SCREW SH M3x14 (10)
- 940513 BALL-BEARING 5x12x4 RUBBER SEALED - GREASE (2)
- 960030 NUT M3 (10)
- 980210 PIN 2x10 (10)

- 2x 980210 P 2x10

2x L=R

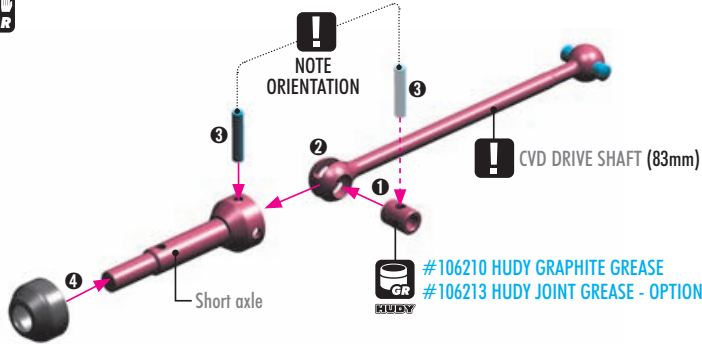

OPTION

FRONT DRIVE SHAFTS (2.5mm PIN)

OPTION	Part #	Material	Length	Status
	#365202	ECS	83mm	OPTION
	#365225	CVD	83mm	INCLUDED
	#365226	CVD	84mm	OPTION



- 2x 359050 BB 5x10x4

2x L=R

Use HUDY Ball-Bearing Grease

- #106220 - STANDARD
- #106221 - BLUE
- #106222 - RED

- 2x 940513 BB 5x12x4

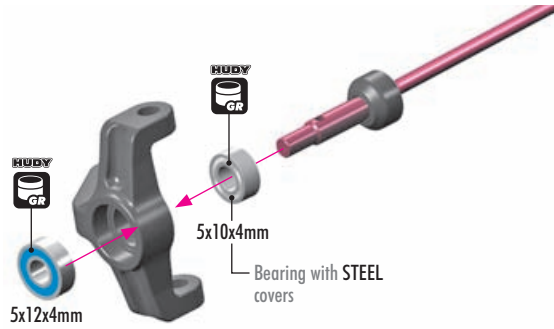

OPTION

XRAY BALL-BEARINGS

OPTION	Part #	Size	Material	Status
	#940510	5x10x4	OIL	OPTION
	#940512	5x12x4	OIL	OPTION
	#359050	5x10x4	GREASE	INCLUDED
	#940513	5x12x4	GREASE	INCLUDED

- 2x 902205 SH M2x5

2x L=R

- 2x 980210 P 2x10

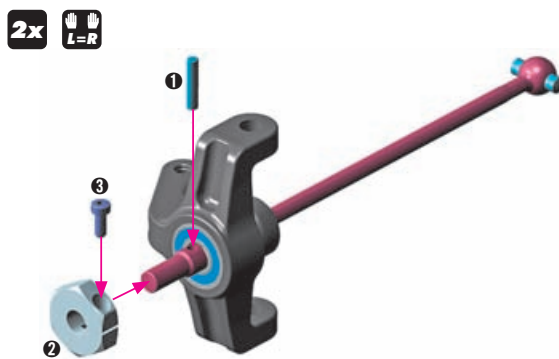

OPTION

WHEEL HUBS 12MM

OPTION	Part #	Offset	Slots	Status
	#365360	+4.5mm	- 6 SLOTS	OPTION
	#365359	+3.75mm	- 5 SLOTS	OPTION
	#365358	+3.0mm	- 4 SLOTS	OPTION
	#365357	+2.25mm	- 3 SLOTS	OPTION
	#365356	+1.5mm	- 2 SLOTS	INCLUDED
	#365355	+0.75mm	- 1 SLOT	OPTION
	#365353	0mm	- 0 SLOTS	OPTION
	#365354	-0.75mm	- Lightw.	OPTION
	#365361	-1.25mm	- Lightw.	OPTION

OPTIONAL HEX HUB EFFECTS

Different off-set hex hubs are used to increase or decrease the track-width.

LESS OFF-SET

Rear - more traction
Front - more steering

MORE OFF-SET

Rear - less traction
Front - less steering

- 2x 362280 CON. SHIM 3x6x2

- 2x 902312 SH M3x12

- 2x 902314 SH M3x14

IMPORTANT
Be sure to use the shorter screw with shorter bushing and longer screw with longer bushing.

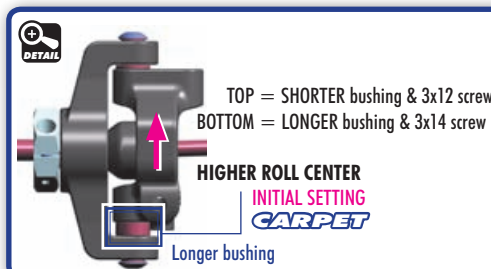
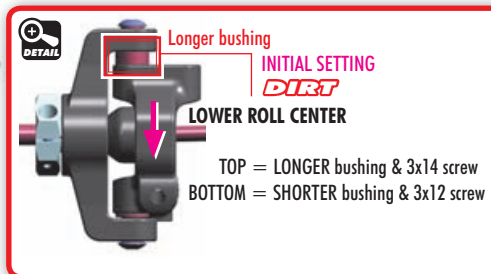
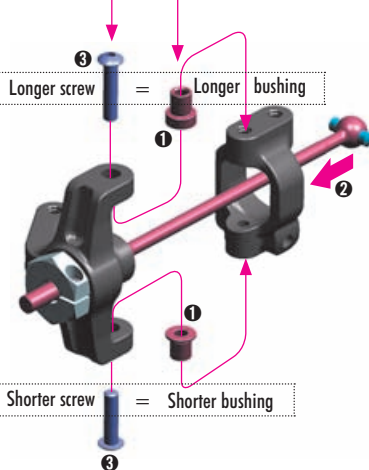

8mm THREAD

NOTE ORIENTATION

CONICAL SHIM 3x6x2mm

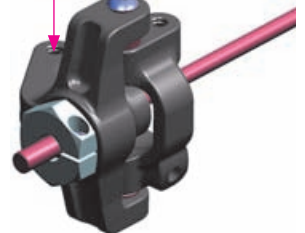

OPTION

#360900 ALU STEER. BLOCKS & 7° C-HUBS - SET



SET-UP BOOK
CASTER
ROLL CENTER

IMPORTANT (LEFT = RIGHT) L=R

When inserting the bushings, make sure that bushings are inserted equally on both right and left hub to give the same roll center position.

4. FRONT TRANSMISSION

2x 901306
SB M3x6

2x
L=R

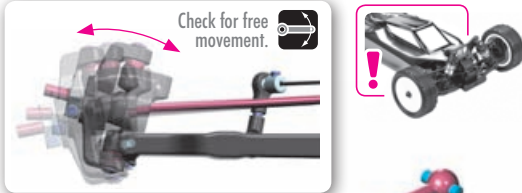

DO NOT OVERTIGHTEN

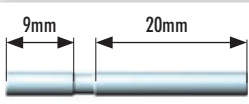

1:1 NOTE ORIENTATION

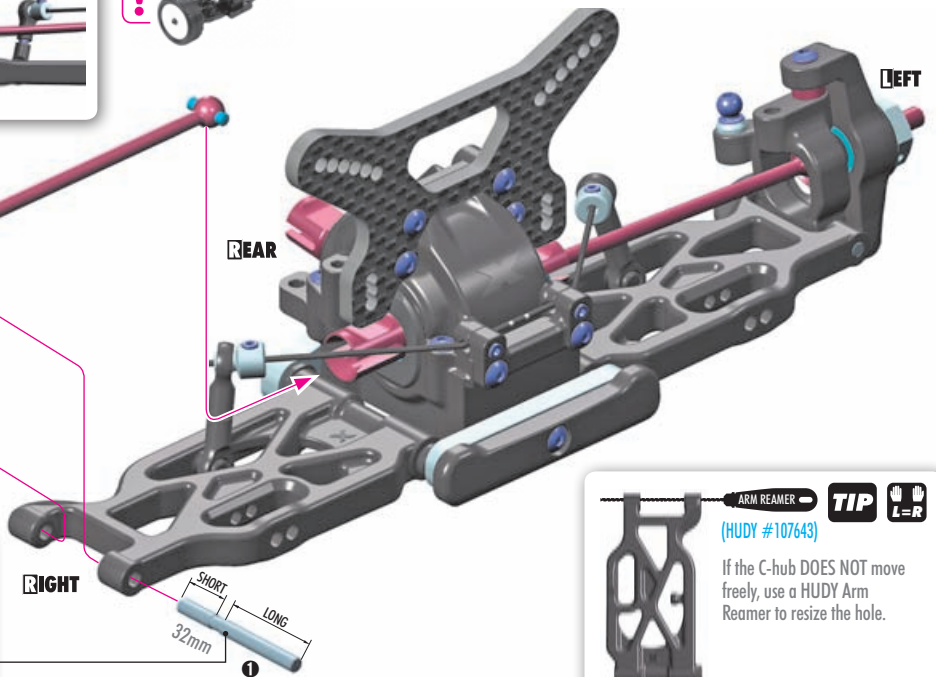

ARM REAMER (HUDY #107643) **TIP** L=R

If the C-hub DOES NOT move freely, use a HUDY Arm Reamer to resize the hole.

SET-UP BOOK
CAMBER

2x
L=R

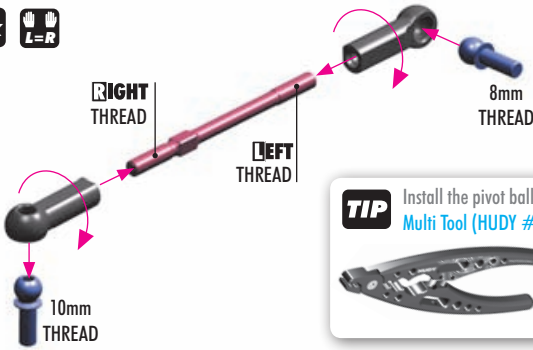

TIP Install the pivot balls with Professional Multi Tool (HUDY #183011).



HUDY TITAN BALL ENDS			
OPTION	#990008	8mm Thread	OPTION
OPTION	#990010	10mm Thread	OPTION

2x 362280
CON. SHIM 3x6x2

2x 960030
N M3



NOTE ORIENTATION

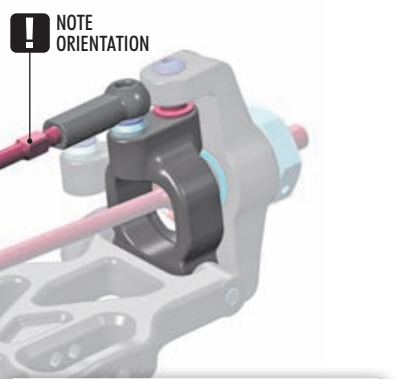

ALU CONICAL SHIMS			
OPTION	#362280	SILVER	INCLUDED
OPTION	#362280-K	BLACK	OPTION
OPTION	#362280-O	ORANGE	OPTION

ALU NUTS M3			
OPTION	#296530-B	BLUE	OPTION
OPTION	#296530-K	BLACK	OPTION
OPTION	#296530-O	ORANGE	OPTION
OPTION	#960031	SILVER	OPTION

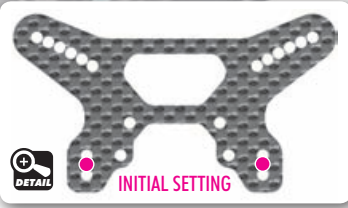

SET-UP BOOK
ROLL CENTER

4. FRONT & REAR ASSEMBLY

CARPET **DIRT**

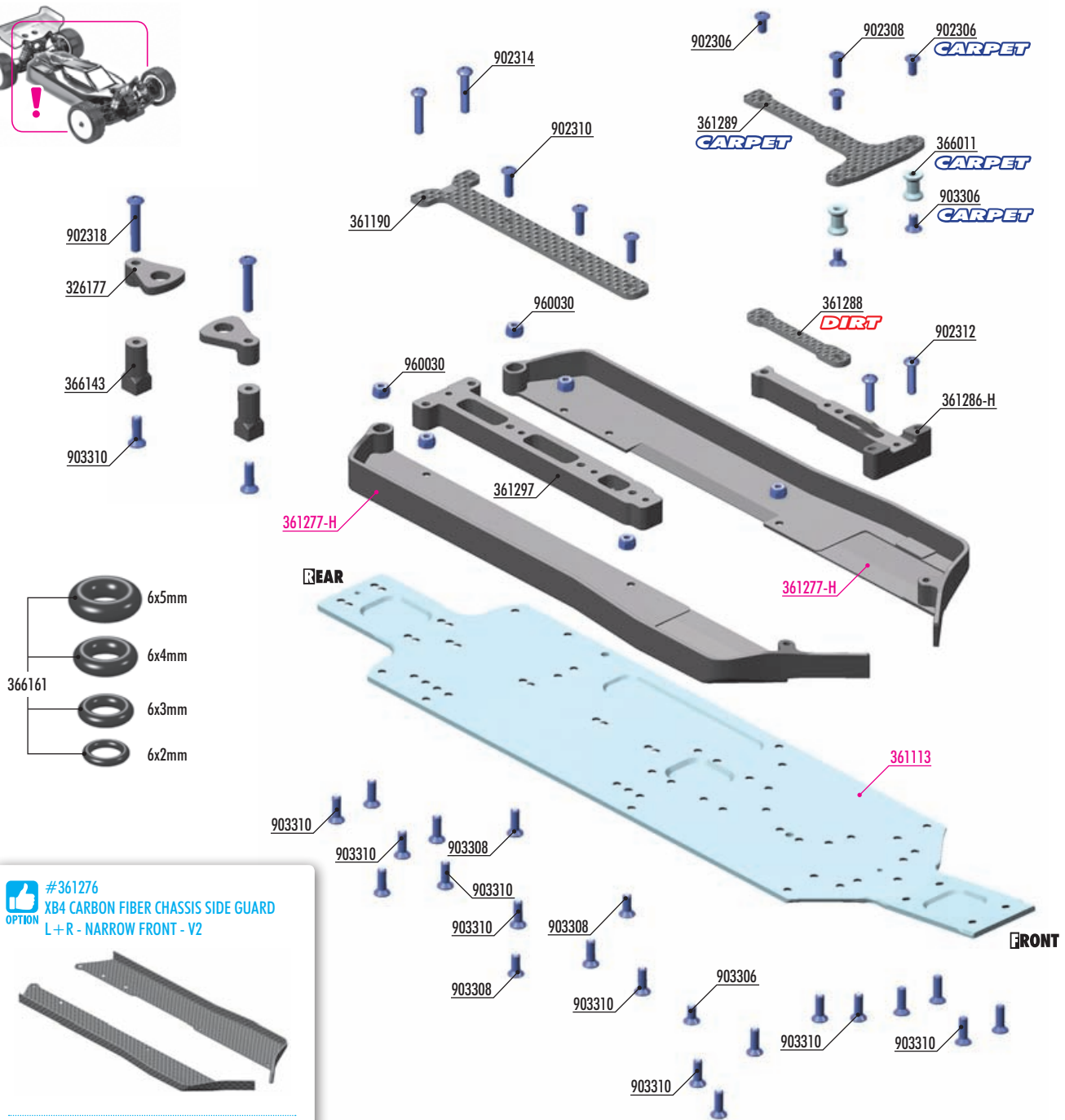
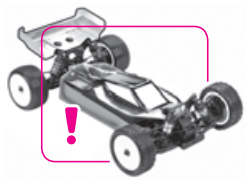

- 6x5mm
- 6x4mm
- 6x3mm
- 6x2mm

#361276
OPTION XB4 CARBON FIBER CHASSIS SIDE GUARD L+R - NARROW FRONT - V2

#361277-G
OPTION COMPOSITE CHASSIS SIDE GUARDS L+R NARROW FRONT - V2 - GRAPHITE

#361114
OPTION ALU CHASSIS 2.5mm WITH ADJUST. TRANSMISSION POSITION

#361191
OPTION BRASS CHASSIS BRACE REAR (40g)

#361295
OPTION COMPOSITE CHASSIS BRACE REAR - MEDIUM



- 326177 COMPOSITE BATTERY CLAMP (2)
- 361190 GRAPHITE CHASSIS BRACE UPPER DECK 2.2MM
- 361286-H COMPOSITE CHASSIS BRACE FRONT - HARD
- 361288 GRAPHITE CHASSIS WIRE COVER 2.2MM
- 361289 GRAPHITE CHASSIS T-BRACE - FRONT - 2.2MM
- 361297 COMPOSITE CHASSIS BRACE REAR - HARD
- 366011 ALU BRACE MOUNT - SWISS 7075 T6 (2)
- 366143 COMPOSITE BATTERY HOLDER STAND (2)
- 366161 SET OF O-RINGS (6x2, 6x3, 6x4, 6x5MM)
- 902306 HEX SCREW SH M3x6 (10)
- 902308 HEX SCREW SH M3x8 (10)

- 902310 HEX SCREW SH M3x10 (10)
- 902312 HEX SCREW SH M3x12 (10)
- 902314 HEX SCREW SH M3x14 (10)
- 902318 HEX SCREW SH M3x18 (10)
- 903306 HEX SCREW SFH M3x6 (10)
- 903308 HEX SCREW SFH M3x8 (10)
- 903310 HEX SCREW SFH M3x10 (10)
- 960030 NUT M3 (10)

- 361113 ALU CHASSIS 2mm WITH ADJUSTABLE TRANSMISSION POSITION
- 361277-H COMPOSITE CHASSIS SIDE GUARDS L+R - NARROW FRONT - V2



4x 903308
SFH M3x8



4x 903310
SFH M3x10



6x 960030
N M3

SET-UP BOOK

CHASSIS FLEX

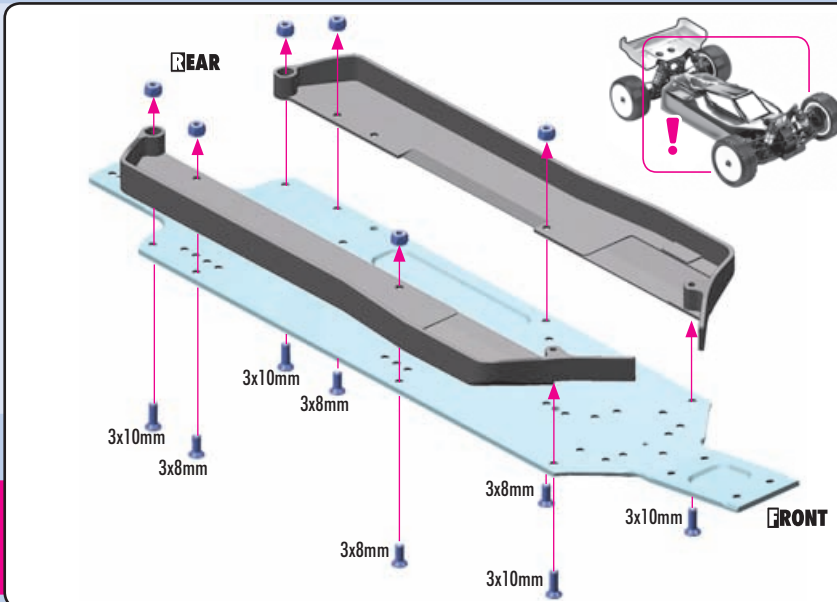

#361276

XB4 CARBON FIBER CHASSIS SIDE GUARD
L+R - NARROW FRONT - V2

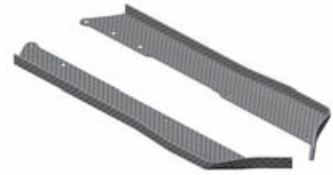

#361277-G

COMPOSITE CHASSIS SIDE GUARDS L+R
NARROW FRONT - V2 - GRAPHITE



3x 902310
SH M3x10



1x 903306
SFH M3x6



6x 903310
SFH M3x10

NOTE
ORIENTATION

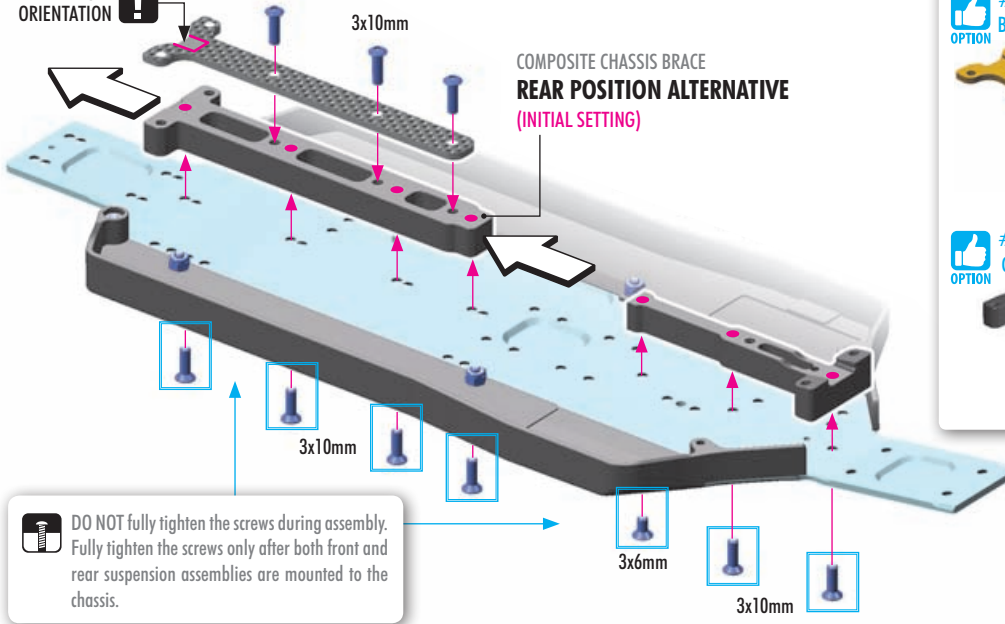

#361191

BRASS CHASSIS BRACE REAR (40g)



#361295

COMPOSITE CHASSIS BRACE REAR
- MEDIUM



DIRT

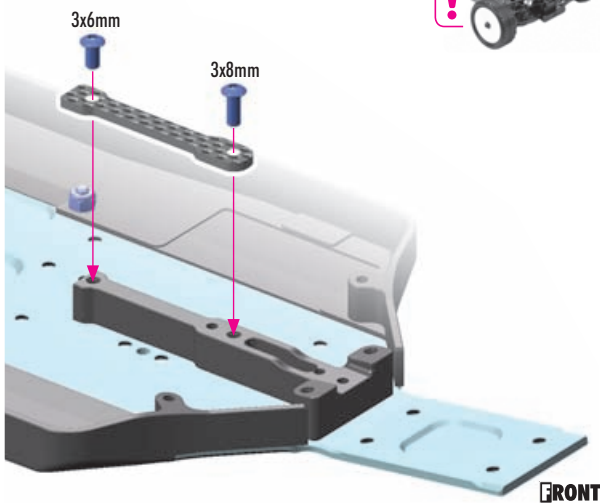

CARPET

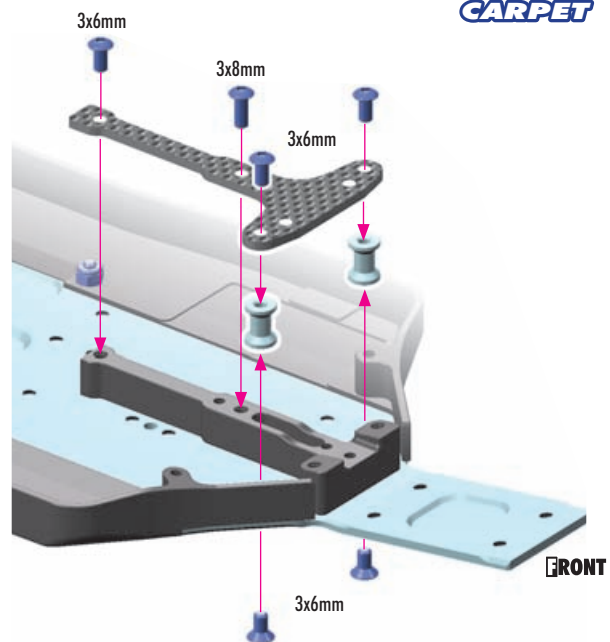

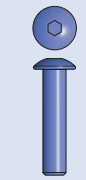

2x 902314 SH M3x14

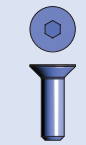

4x 903310 SFH M3x10

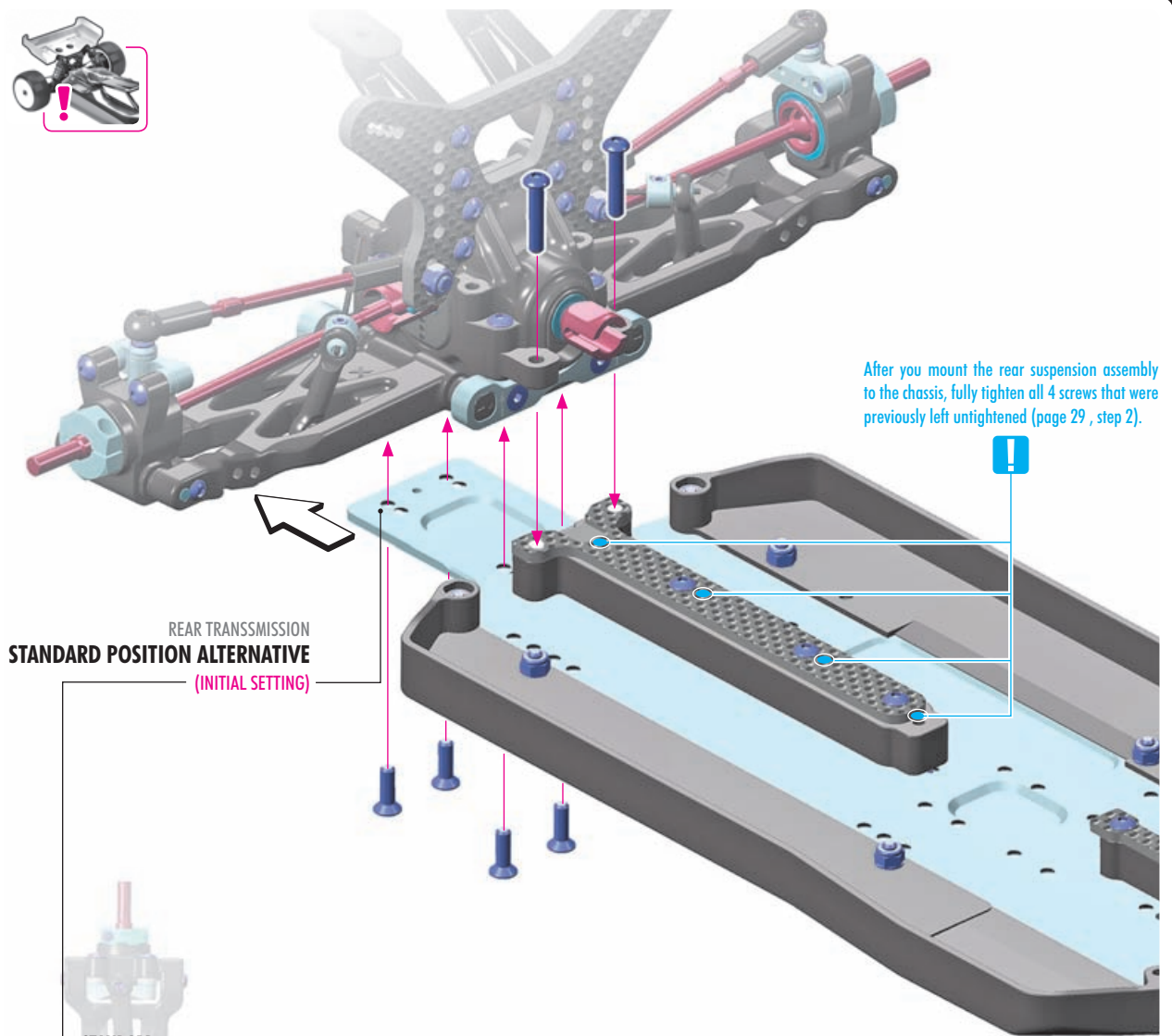

After you mount the rear suspension assembly to the chassis, fully tighten all 4 screws that were previously left untightened (page 29, step 2).

REAR TRANSMISSION
STANDARD POSITION ALTERNATIVE
(INITIAL SETTING)

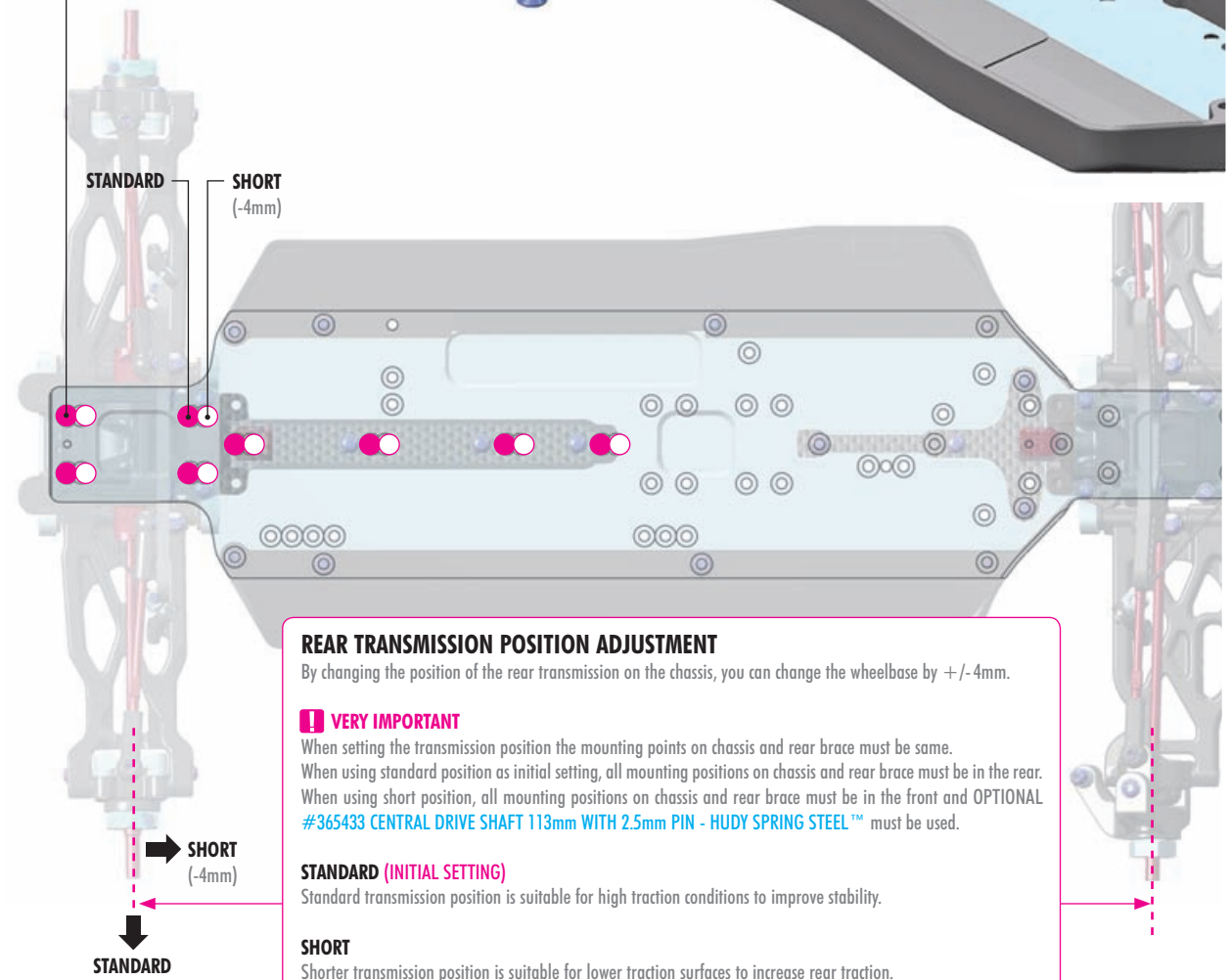

REAR TRANSMISSION POSITION ADJUSTMENT

By changing the position of the rear transmission on the chassis, you can change the wheelbase by +/- 4mm.

VERY IMPORTANT

When setting the transmission position the mounting points on chassis and rear brace must be same.
When using standard position as initial setting, all mounting positions on chassis and rear brace must be in the rear.
When using short position, all mounting positions on chassis and rear brace must be in the front and **OPTIONAL #365433 CENTRAL DRIVE SHAFT 113mm WITH 2.5mm PIN - HUDY SPRING STEEL™** must be used.

STANDARD (INITIAL SETTING)

Standard transmission position is suitable for high traction conditions to improve stability.

SHORT

Shorter transmission position is suitable for lower traction surfaces to increase rear traction.

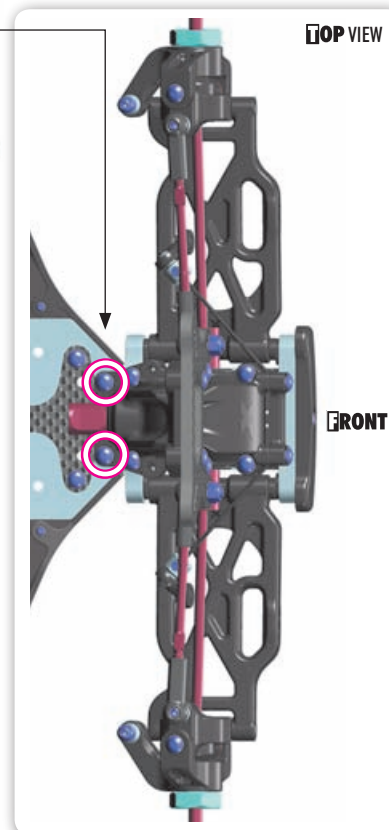
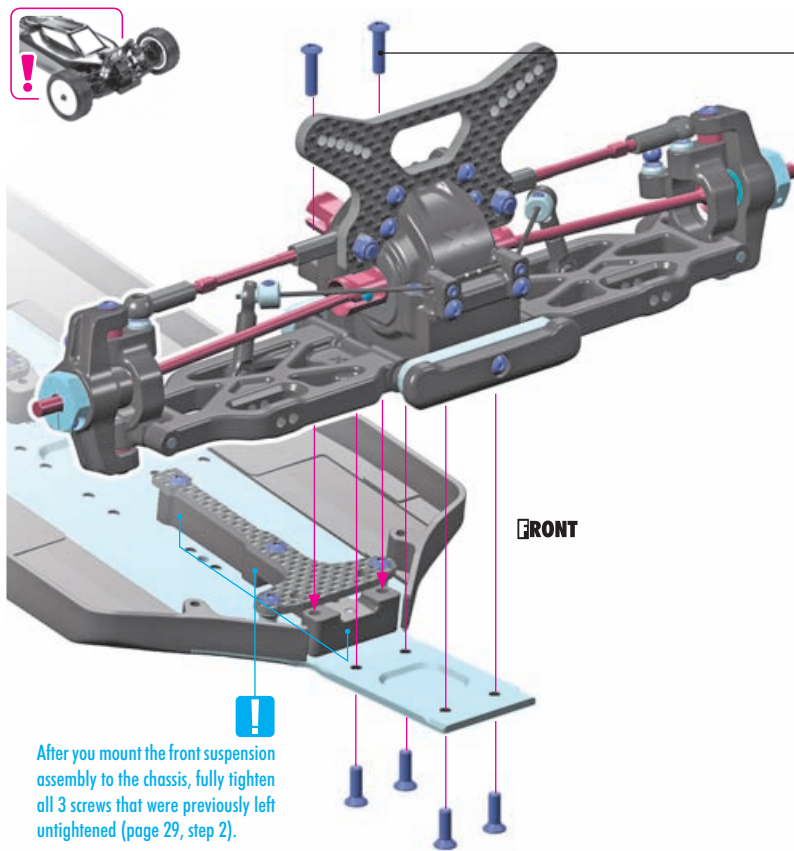
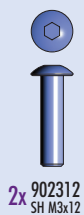

After you mount the front suspension assembly to the chassis, fully tighten all 3 screws that were previously left untightened (page 29, step 2).



TIP Hold the battery holder with Professional Multi Tool (HUDY #183011).



Select the battery mount 1/2/3/4 position to match the battery pack length.

When using the 3rd or 4th battery position, it is necessary to remove the nut.

#326181
OPTION
STAINLESS STEEL BATTERY WEIGHT 35G

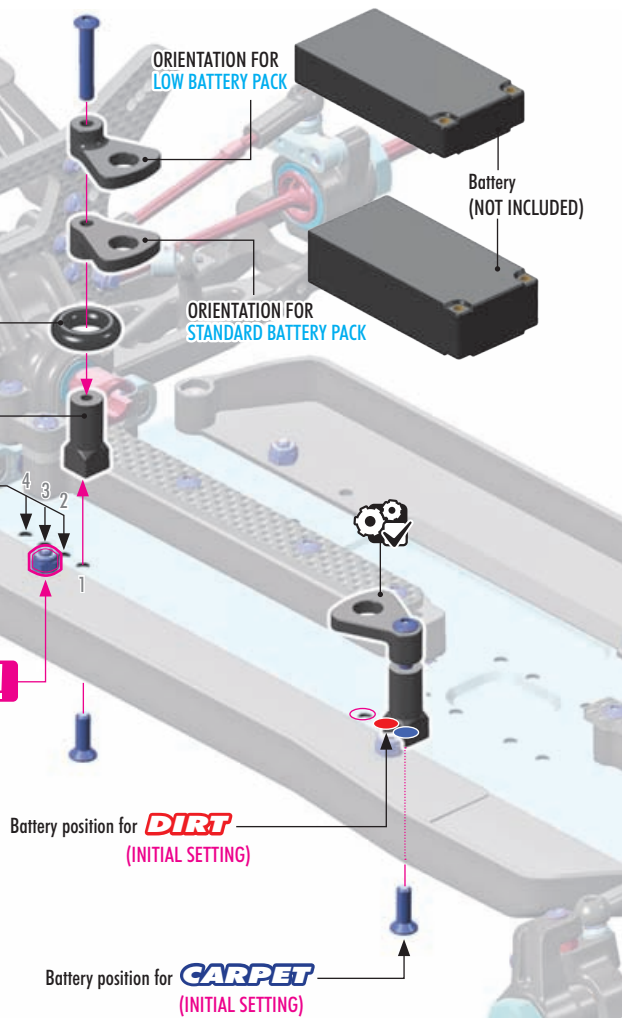

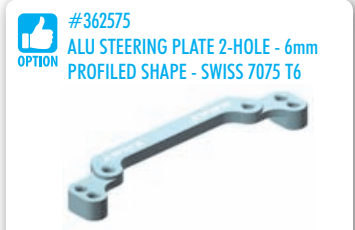
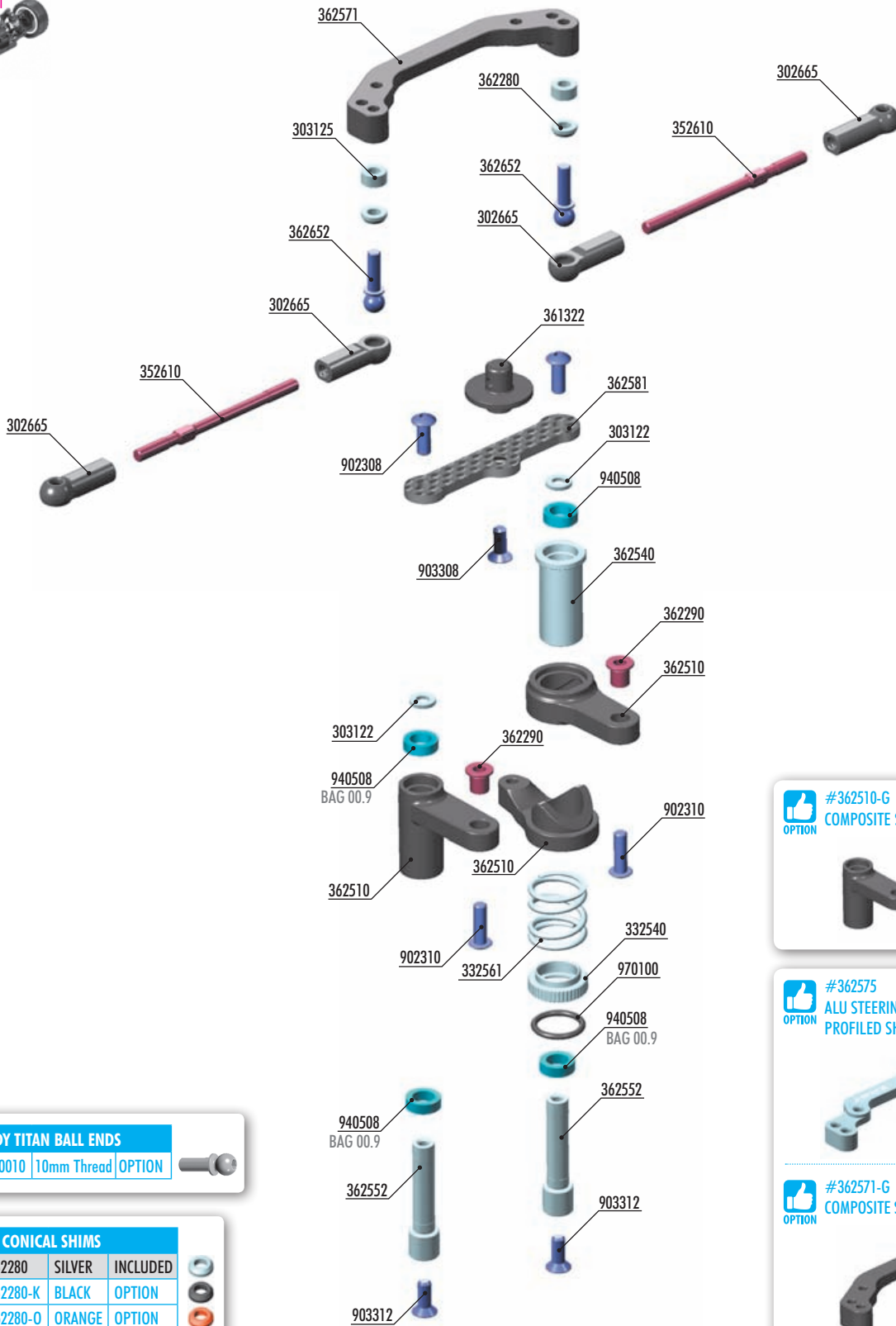
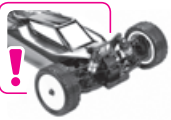

HUDY TITAN BALL ENDS
 #990010 | 10mm Thread | OPTION

ALU CONICAL SHIMS			
#362280	SILVER	INCLUDED	
#362280-K	BLACK	OPTION	
#362280-O	ORANGE	OPTION	

BAG

302665	COMPOSITE BALL JOINT 4.9MM - CLOSED WITH HOLE (4)	362552	SERVO SAVER PIVOT SHAFT +5MM (2)
303122	ALU SHIM 3x6x1.0MM (10)	362571	COMPOSITE STEERING PLATE
303125	ALU SHIM 3x6x3.0MM (10)	362581	STEERING BRACE 2.0MM GRAPHITE
332540	ALU SERVO SAVER ADJUSTABLE NUT	362652	BALL END 4.9MM WITH THREAD 10MM (2)
332561	SERVO SAVER SPRING C=14	902308	HEX SCREW SH M3x8 (10)
352610	ADJ. TURNBUCKLE M3 L/R 45MM - SPRING STEEL (2)	902310	HEX SCREW SH M3x10 (10)
361322	BODY MOUNT - EXTRA-SHORT	903308	HEX SCREW SFH M3x8 (10)
362280	ALU CONICAL SHIM 3x6x2.0MM (10)	903312	HEX SCREW SFH M3x12 (10)
362290	STEEL STEERING BUSHING - SHORT (2)	940508	BALL-BEARING 5x8x2.5 RUBBER SEALED - OIL (2)
362510	COMPOSITE SERVO SAVER	970100	O-RING 10 x 1.5 (10)
362540	ALU SERVO SAVER MAIN SHAFT		



1x 970100
O 16x1.5

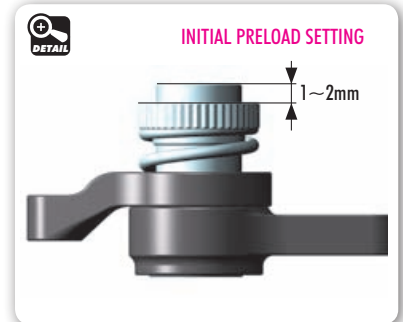
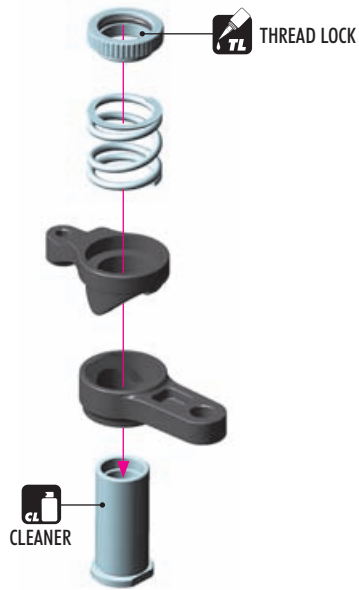

SET-UP BOOK

SERVO SAVER



2x 902310
SH M3x10

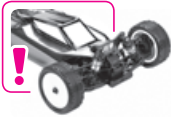

NOTE ORIENTATION

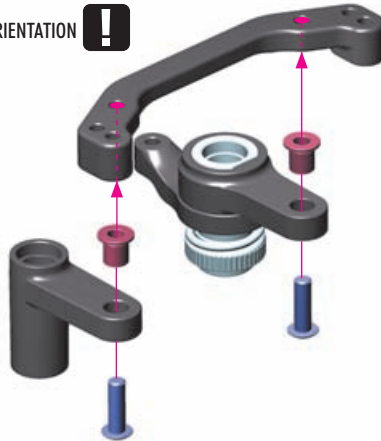

STEERING PLATES

OPTION	STEERING PLATES	INCLUDED
#362571	HARD	INCLUDED
#362571-G	GRAPHITE	OPTION
#362575	ALU	OPTION



Increases steering precision and predictability and is recommended for use in high-traction conditions. Includes extra Ackermann positions for very precise steering adjustment.



2x 303122
SHIM 3x6x1



2x 902308
SH M3x8



1x 903308
SFH M3x8



2x 940508
BB 5x8x2.5

NOTE ORIENTATION

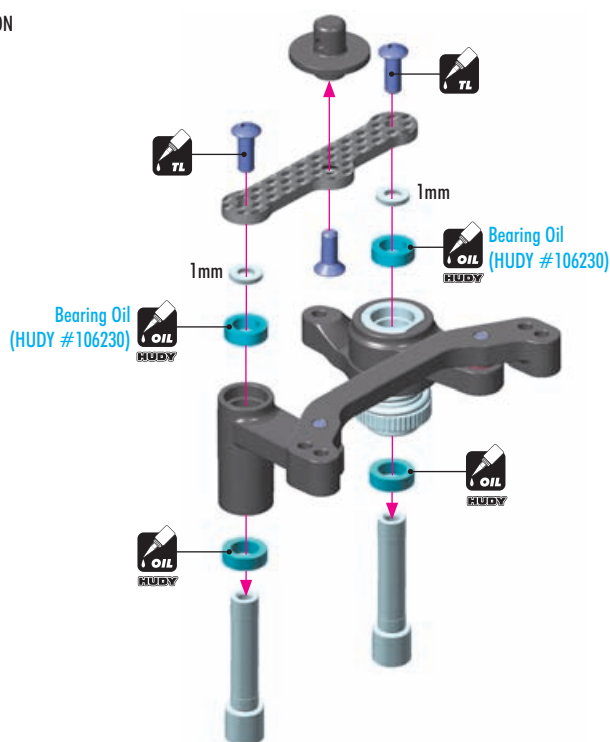
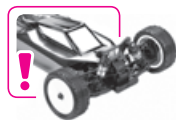



2x 903312
SFH M3x12

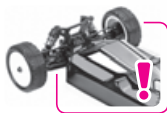
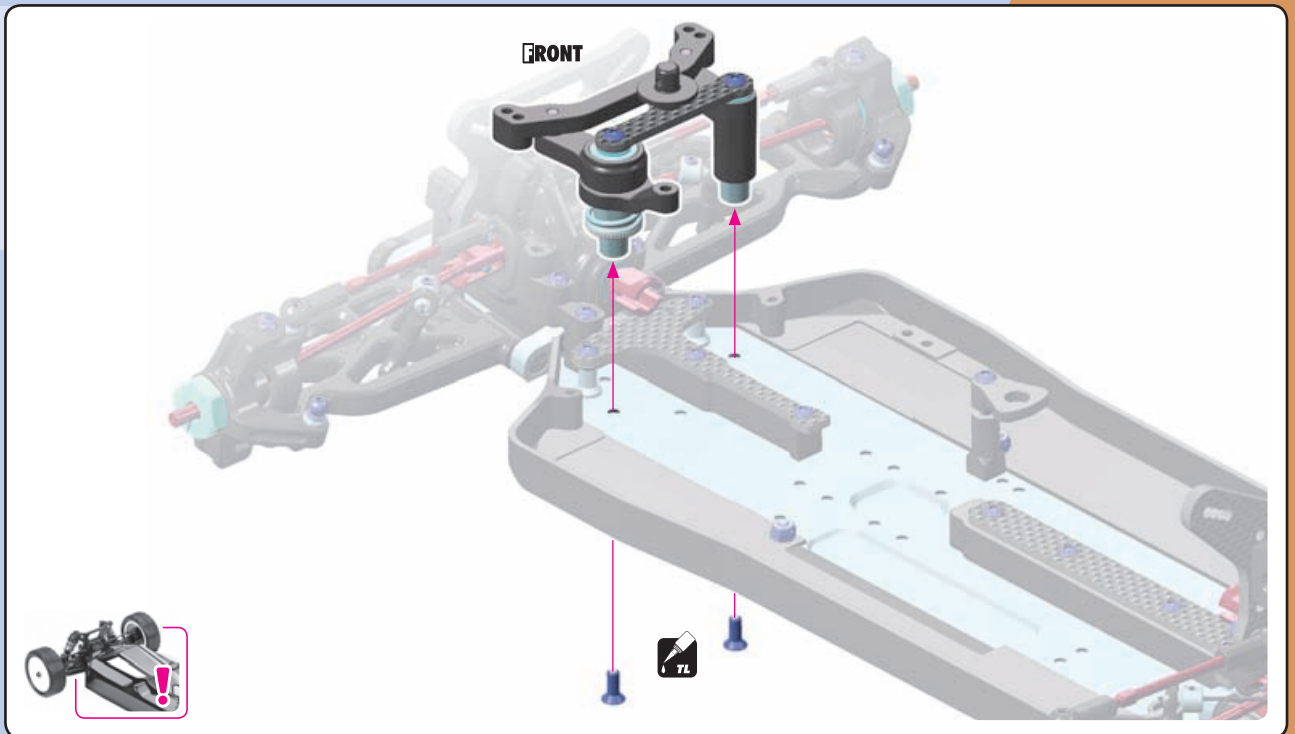

2x L=R

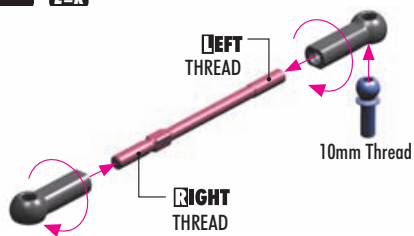

TIP Install the pivot balls with Professional Multi Tool (HUDY #183011).



HUDY TITAN BALL ENDS
#990010 10mm Thread



2x L=R

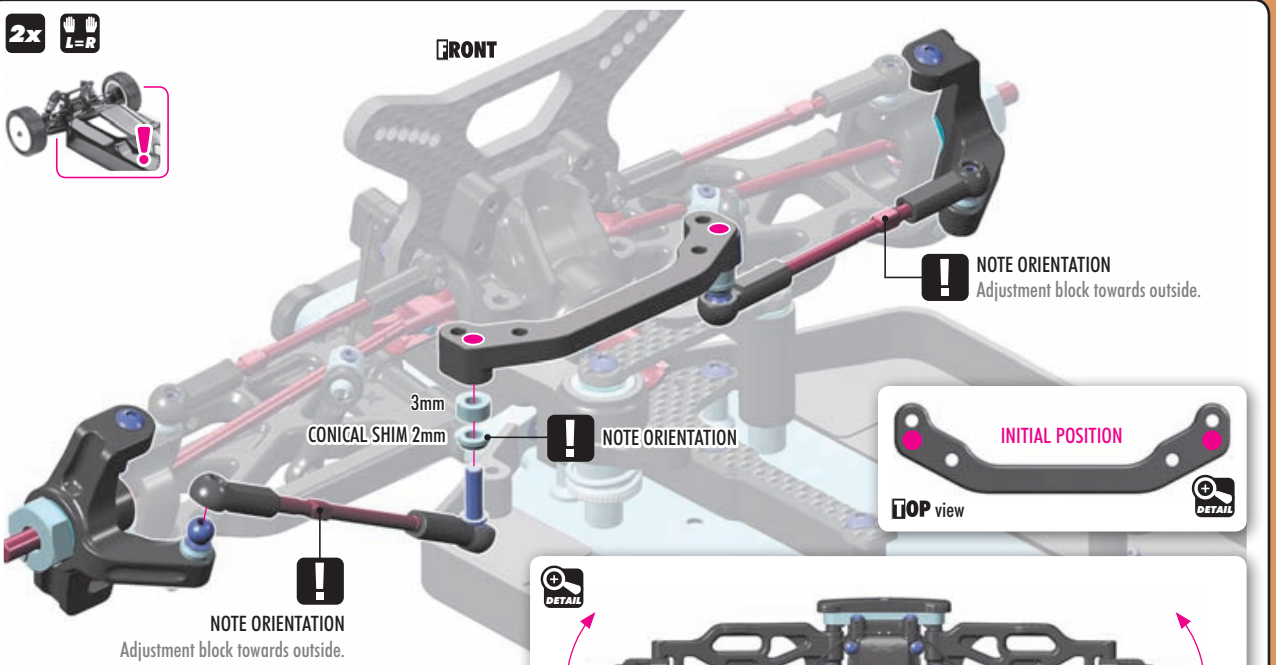
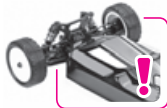

NOTE ORIENTATION
Adjustment block towards outside.

NOTE ORIENTATION



NOTE ORIENTATION
Adjustment block towards outside.

ALU CONICAL SHIMS			
OPTION	#362280	SILVER	INCLUDED
	#362280-K	BLACK	OPTION
	#362280-O	ORANGE	OPTION



SET-UP BOOK
ACKERMANN
BUMP STEER
TOE-IN

6. SLIPPER CLUTCH ASSEMBLY

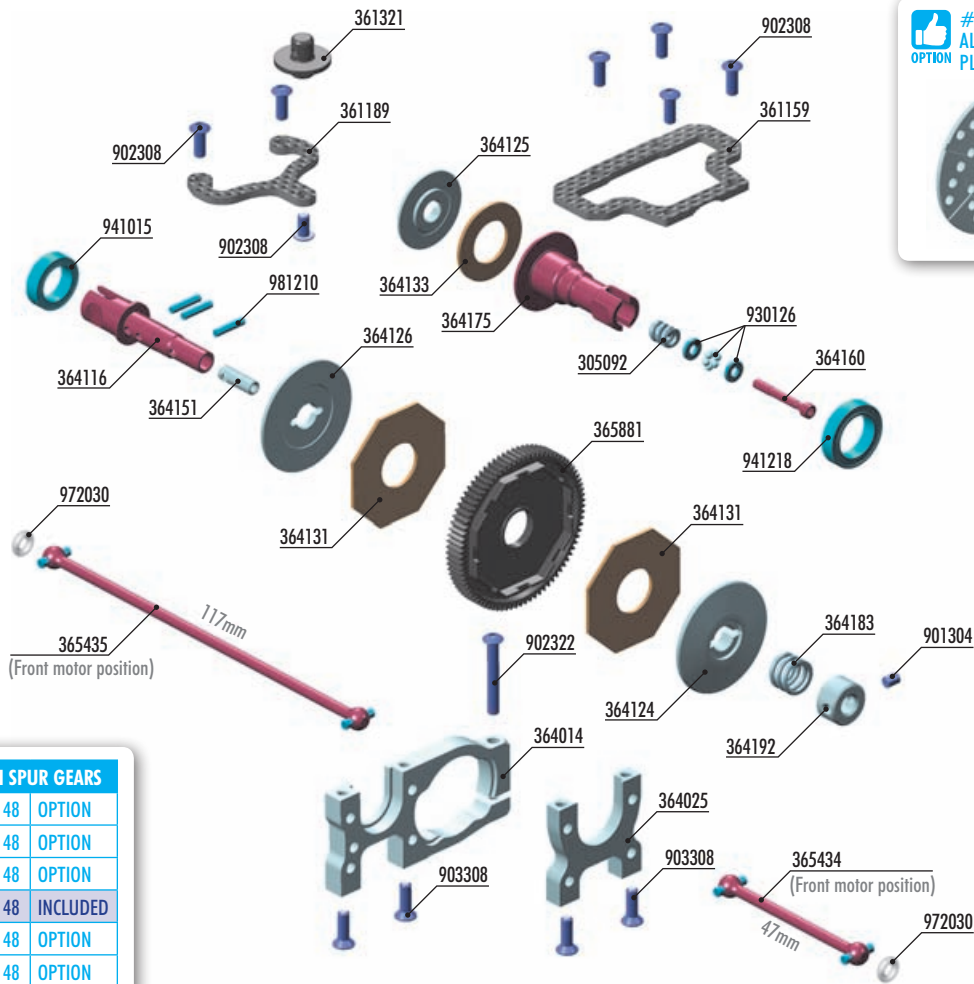
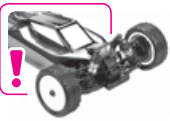

SLIPPER CLUTCH SPUR GEARS		
#365872	72T / 48	OPTION
#365875	75T / 48	OPTION
#365878	78T / 48	OPTION
#365881	81T / 48	INCLUDED
#365884	84T / 48	OPTION
#365887	87T / 48	OPTION

#365439 CENTRAL DOGBONE DRIVE SHAFT 57mm Central dogbone drive shafts for **REAR MOTOR POSITION**

#365437 CENTRAL DOGBONE DRIVE SHAFT 107mm

#365437 CENTRAL DOGBONE DRIVE SHAFT 113mm Central dogbone drive shafts for **SHORT TRANSMISSION POSITION**

CENTER DIFF CONVERSION

SLIPPER ELIMINATOR

or

You need +

#365436 CENTRAL DOGBONE DRIVE SHAFT 65mm - HUDY SPRING STEEL™

#364024 ALU CENTRAL BULKHEAD or **#364023** COMPOSITE CENTRAL BULKHEAD

#361176 GRAPHITE CENTER UPPER DECK - V2



- 305092 BALL DIFFERENTIAL SPRING
- 361159 GRAPHITE CENTER UPPER DECK 2.2MM
- 361189 GRAPHITE REAR BODY POST HOLDER 2.2MM
- 361321 BODY MOUNT - SHORT + SHIMS - SET
- 364014 ALU MOTOR BULKHEAD - NARROW
- 364025 ALU CENTRAL BULKHEAD - SWISS 7075 T6
- 364116 ONE-WAY SLIPPER CLUTCH SHAFT - HUDY SPRING STEEL™
- 364124 ALU PLATE FOR ONE-WAY SLIPPER CLUTCH - FRONT - SWISS 7075 T6
- 364125 ALU PLATE FOR ONE-WAY SLIPPER CLUTCH FOR OUTDRIVE - SWISS 7075 T6
- 364126 ALU PLATE FOR ONE-WAY SLIPPER CLUTCH - REAR - SWISS 7075 T6
- 364131 SLIPPER CLUTCH PAD SLS - SOFT (3)
- 364133 SLIPPER CLUTCH ONE-WAY OUTDRIVE PAD SLS - SOFT (2)
- 364151 STEEL BUSHING FOR ONE-WAY SLIPPER CLUTCH
- 364160 SCREW FOR ONE-WAY SLIPPER CLUTCH ADJUSTMENT - HUDY SPRING STEEL™
- 364175 OUTDRIVE ADAPTER WITH PRESSED ONE-WAY BEARING - HUDY SPRING STEEL™
- 364183 SLIPPER CLUTCH SPRING C=50 - BLACK
- 364192 ALU NUT FOR ONE-WAY SLIPPER CLUTCH
- 365434 CENTRAL DOGBONE DRIVE SHAFT 47MM - HUDY SPRING STEEL™
- 365435 CENTRAL DOGBONE DRIVE SHAFT 117MM - HUDY SPRING STEEL™
- 365881 COMPOSITE SLIPPER CLUTCH SPUR GEAR 81T / 48 - GRAPHITE
- 901304 HEX SCREW SB M3x4 (10)
- 902308 HEX SCREW SH M3x8 (10)
- 902322 HEX SCREW SH M3x22 (10)
- 903308 HEX SCREW SFH M3x8 (10)
- 930126 CARBIDE BALL-BEARING AXIAL 2.6x6x1
- 941015 BALL-BEARING 10x15x4 RUBBER SEALED - OIL (2)
- 941218 BALL-BEARING 12x18x4 RUBBER SEALED - OIL (2)
- 972030 SILICONE O-RING 3x2 (10)
- 981210 PIN 2x10 (10)

6. SLIPPER CLUTCH ASSEMBLY

-  2x 981210 P 2x10

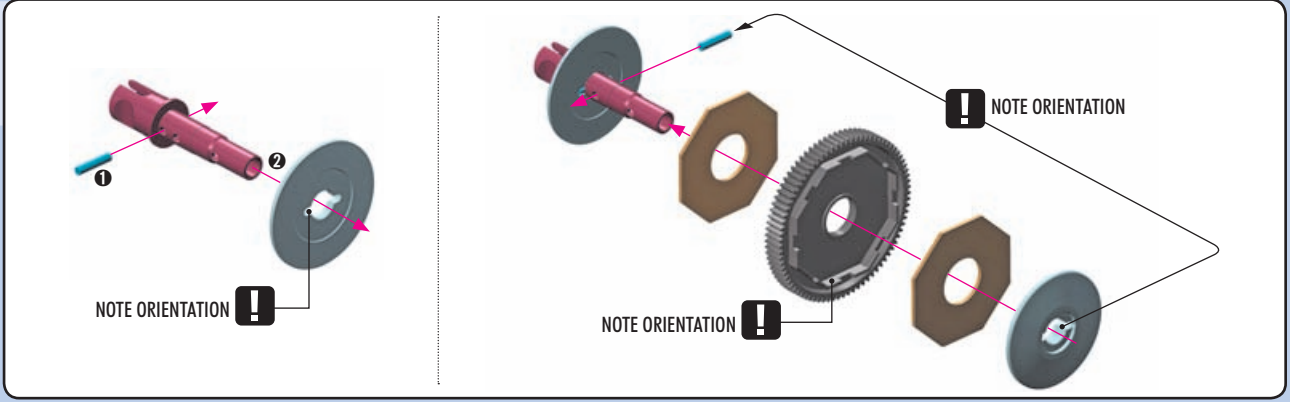

-  1x 901304 SB M3x4

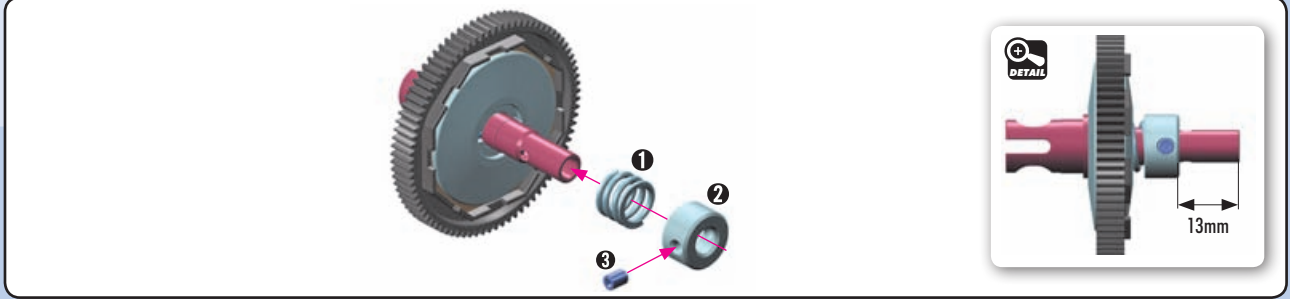

-  1x 980210 P 2x10

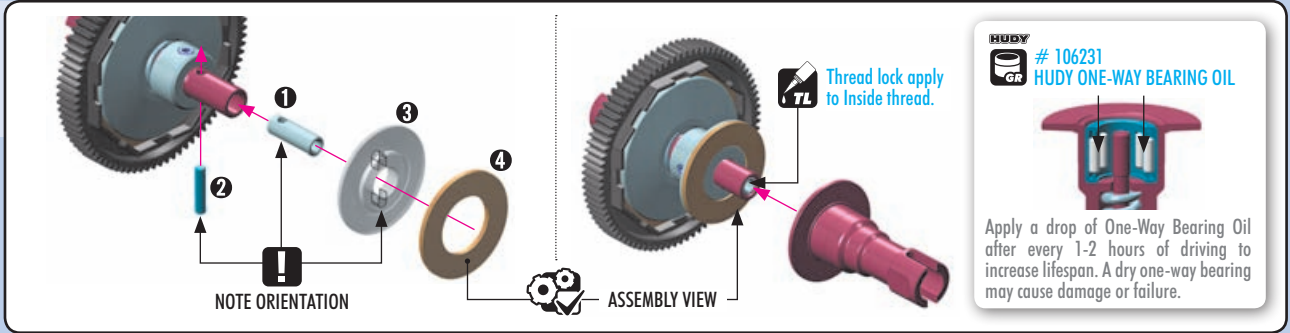



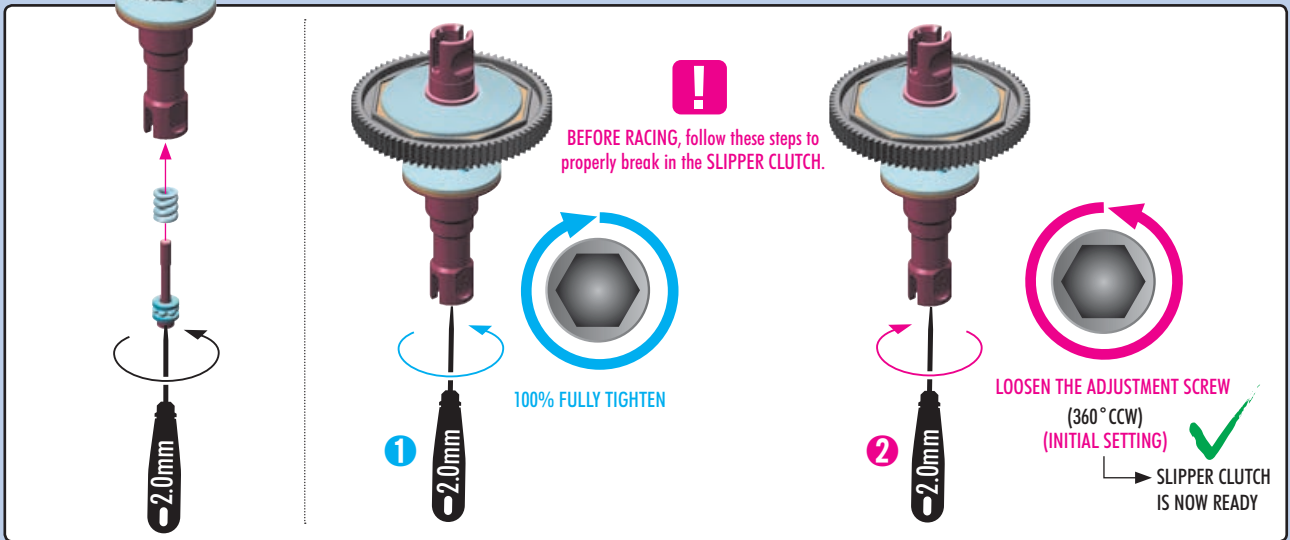
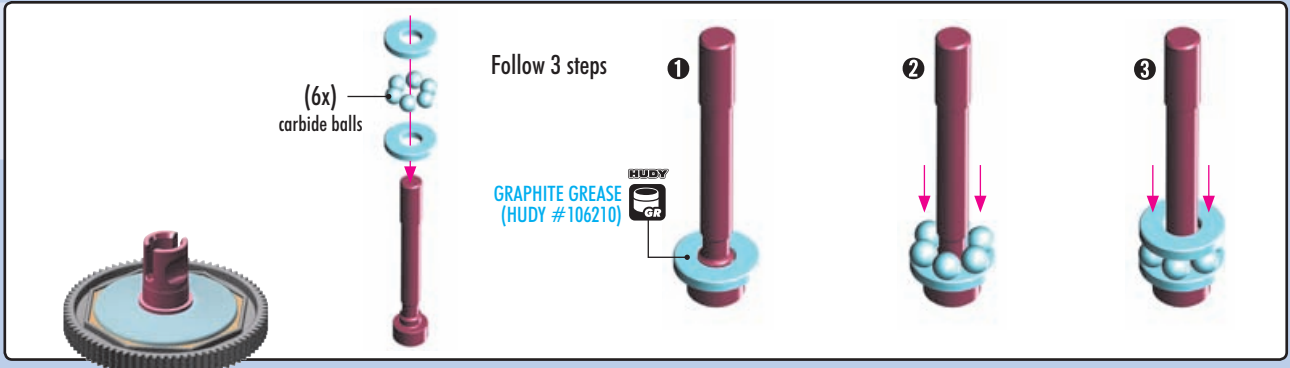

-  1x 930126 BA 2.6x6x1



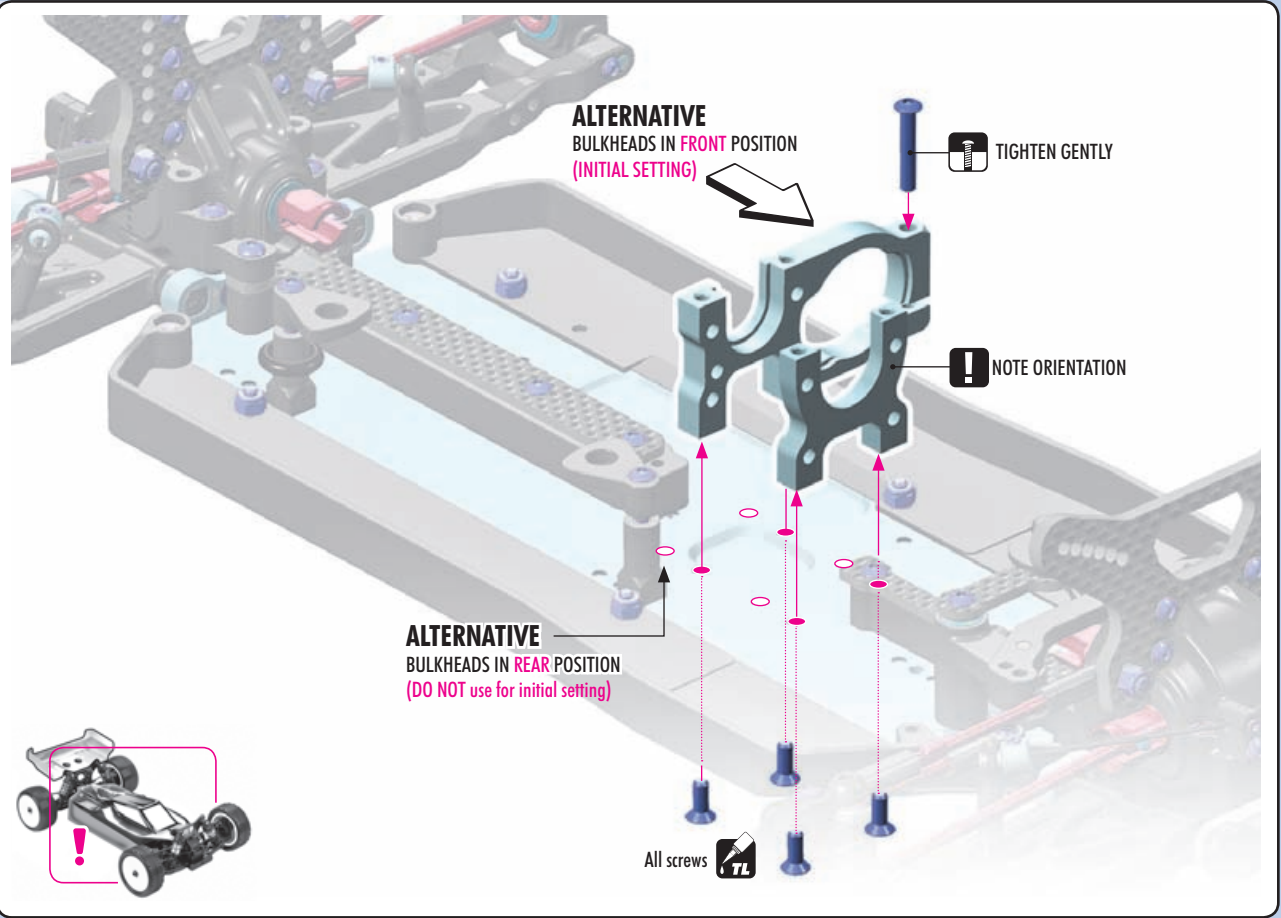

6. SLIPPER CLUTCH ASSEMBLY

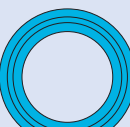
-  1x 902322 SH M3x22
-  4x 903308 SFH M3x8

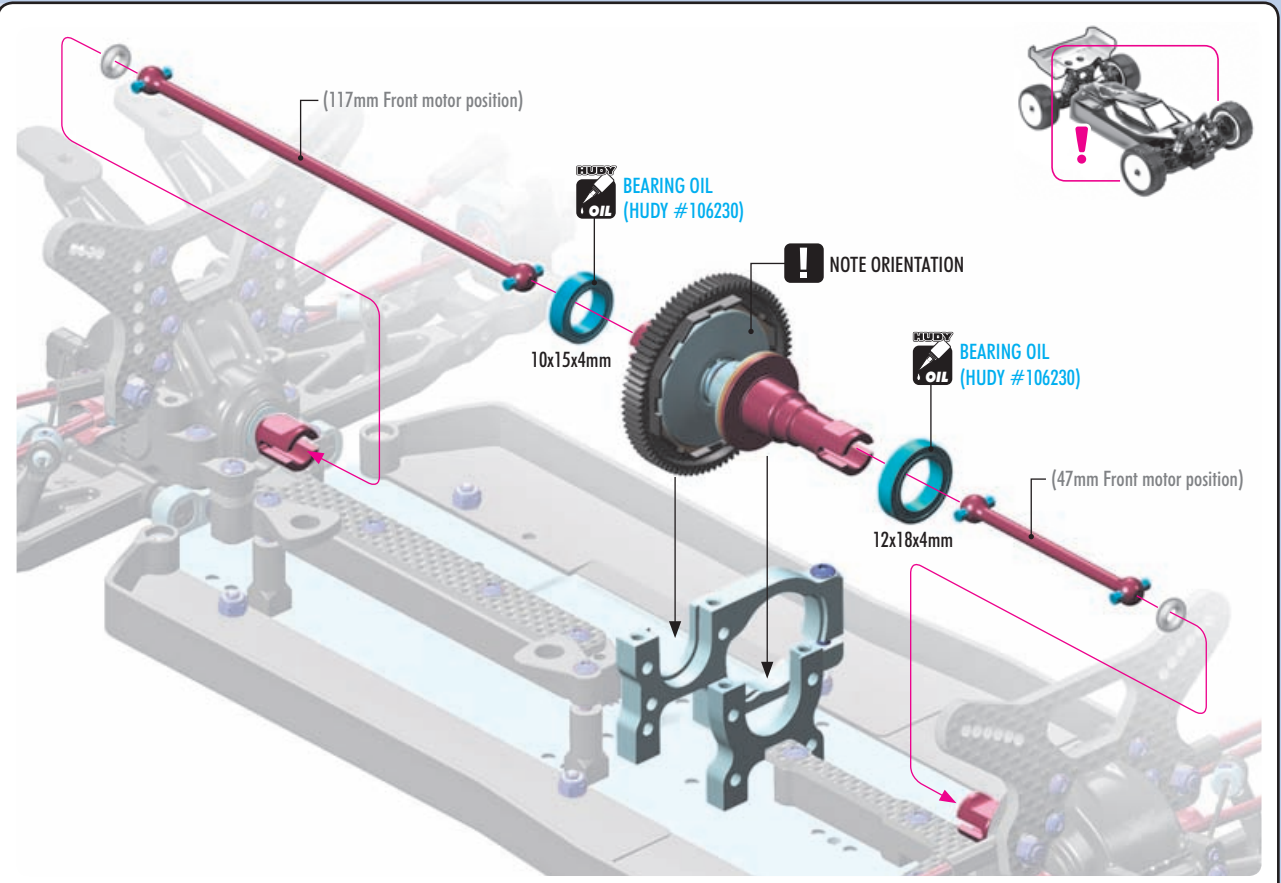

-  1x 941015 BB 10x15x4
-  1x 941218 BB 12x18x4
-  2x 972030 0 3x2



 #365439 CENTRAL DOGBONE DRIVE SHAFT 57mm

 #365437 CENTRAL DOGBONE DRIVE SHAFT 107mm

57mm Central dogbone drive shafts for REAR MOTOR POSITION

107mm

 #365437 CENTRAL DOGBONE DRIVE SHAFT 113mm

Central dogbone drive shafts for SHORT TRANSMISSION POSITION

VERY IMPORTANT!
It is very important that you NEVER FULLY TIGHTEN the Slipper Clutch. Overtightening the Slipper Clutch may result in breakage of the diff crown gear and pinion gear.

CENTRAL SLIPPER CLUTCH ADJUSTMENT

The Slipper Clutch can be adjusted by loosening the set-screw and then, while keeping the tool in the set-screw to prevent movement of the collar, rotating the spur gear by hand as indicated in the drawing.

To LOOSEN: Rotate the spur gear in the counterclockwise (CCW) direction.

- Smoother acceleration on power
- Easier to drive

To TIGHTEN: Rotate the spur gear in the clockwise (CW) direction.

- More forward drive
- Less forgiving

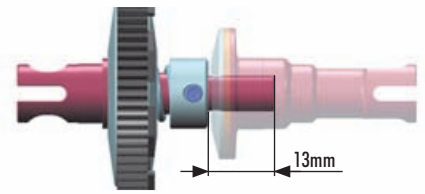

ONE-WAY SLIPPER CLUTCH ADJUSTMENT

For adjusting the front one-way slipper clutch, remove the slipper assembly from car and turn the screw inside the front outdrive using a 2.0mm wrench.

LOOSE - CCW: Greater Rear Brake Bias

- Less weight transfer to front under braking
- Smoother on landings
- Easier to drive

TIGHT - CW: More Aggressive Front Brake Bias

- Less forgiving on landings
- More difficult to drive

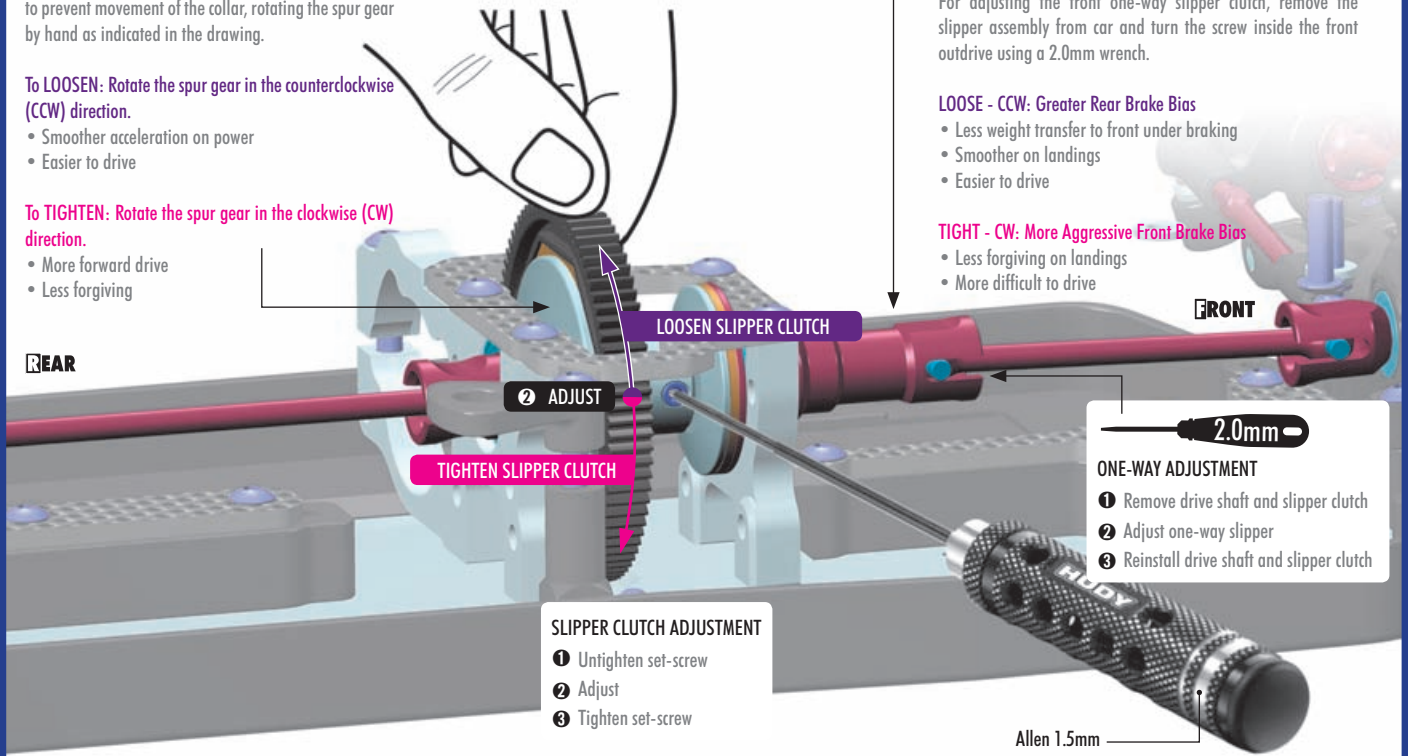

SLIPPER CLUTCH ADJUSTMENT

- 1 Untighten set-screw
- 2 Adjust
- 3 Tighten set-screw

ONE-WAY ADJUSTMENT

- 1 Remove drive shaft and slipper clutch
- 2 Adjust one-way slipper
- 3 Reinstall drive shaft and slipper clutch



7x 902308
SH M3x8

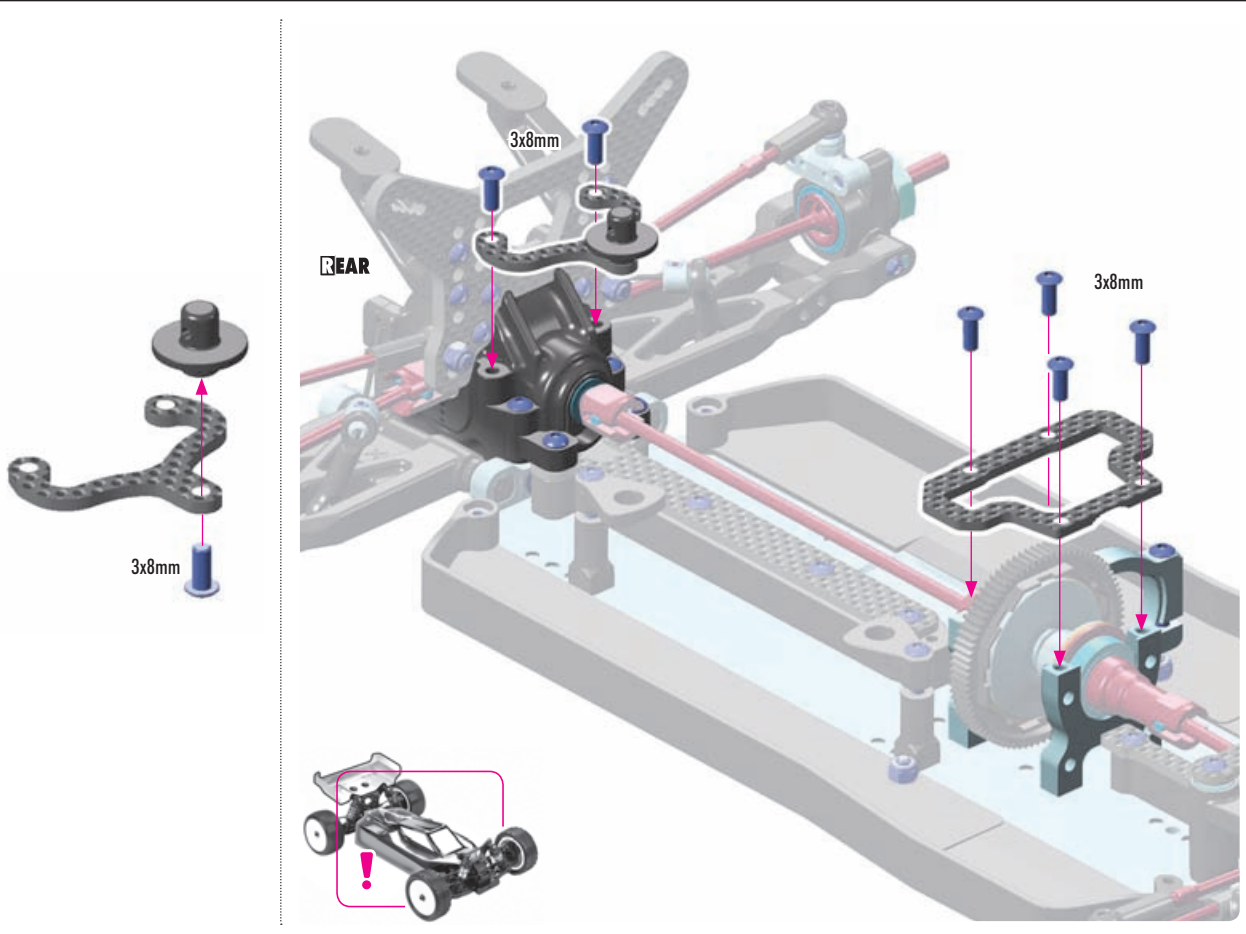

6. CENTER DIFF ASSEMBLY

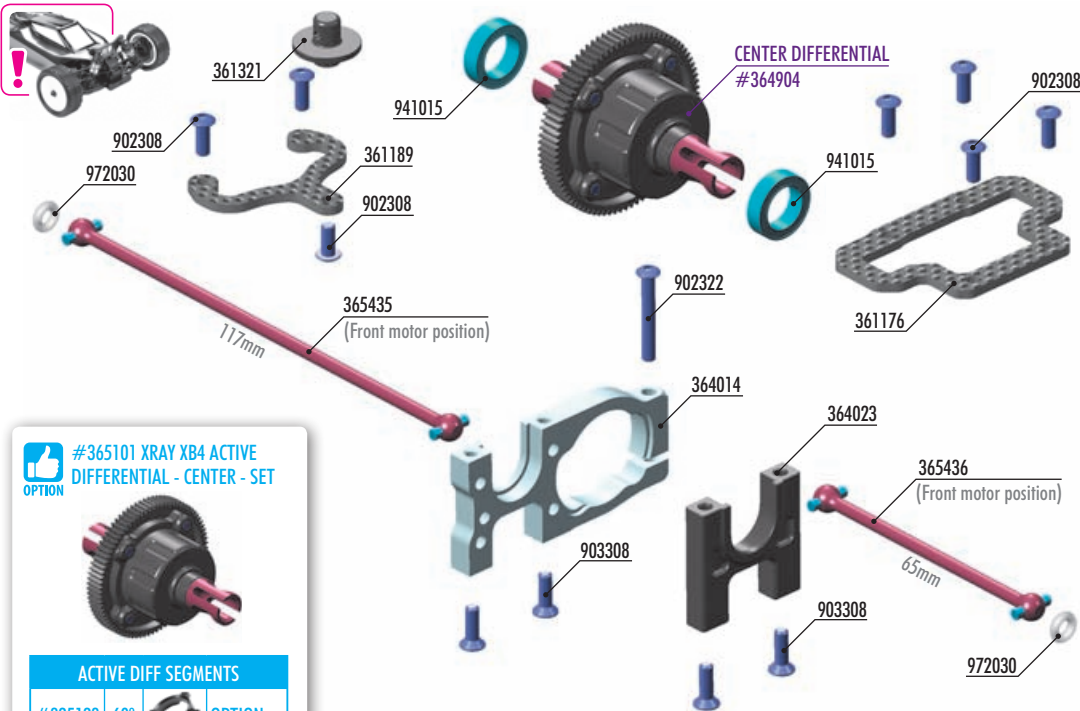

ONE-WAY SLIPPER CLUTCH CONVERSION

#364101 ONE-WAY SLIPPER CLUTCH SET



#365434 CENTRAL DOGBONE DRIVE SHAFT 47mm



#361159 GRAPHITE CENTER UPPER DECK



#364024 ALU CENTRAL BULKHEAD



#365101 XRAY XB4 ACTIVE DIFFERENTIAL - CENTER - SET



ACTIVE DIFF SEGMENTS			
#325123	60°		OPTION
#325125	90°		INCLUDED
#325127	120°		OPTION

#365437 CENTRAL DOGBONE DRIVE SHAFT 113mm
Central dogbone drive shafts for **SHORT TRANSMISSION POSITION**



#365438 CENTRAL DOGBONE DRIVE SHAFT 75mm



#365437 CENTRAL DOGBONE DRIVE SHAFT 107mm



#364102 XB4 SLIPPER ELIMINATOR - SET



BAG 06

- 361176 GRAPHITE CENTER UPPER DECK 2.2MM - V2
- 361189 GRAPHITE REAR BODY POST HOLDER 2.2MM
- 361321 BODY MOUNT - SHORT + SHIMS - SET
- 364014 ALU MOTOR BULKHEAD - NARROW
- 364023 COMPOSITE CENTRAL BULKHEAD - LOWER
- 365435 CENTRAL DOGBONE DRIVE SHAFT 117MM - HUDY SPRING STEEL™
- 365436 CENTRAL DOGBONE DRIVE SHAFT 65MM - HUDY SPRING STEEL™

- 902308 HEX SCREW SH M3x8 (10)
- 902322 HEX SCREW SH M3x22 (10)
- 903308 HEX SCREW SFH M3x8 (10)
- 941015 BALL-BEARING 10x15x4 RUBBER SEALED - OIL (2)
- 972030 SILICONE O-RING 3x2 (10)
- 364904 GEAR CENTER DIFFERENTIAL - LARGE VOLUME - SET

1x 902318 SH M3x18

4x 903308 SFH M3x8

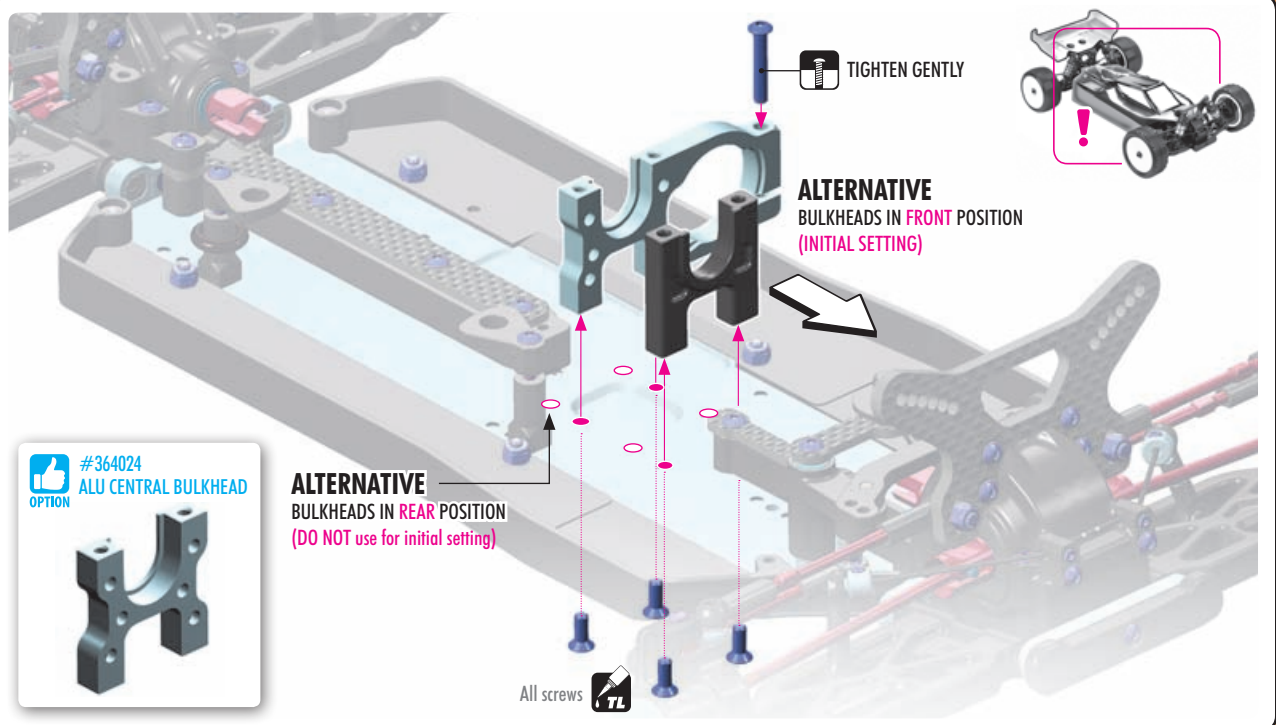

#364024 ALU CENTRAL BULKHEAD



6. CENTER DIFF ASSEMBLY

DIRT



2x 941015
BB 10x15x4



2x 972030
O 3x2

(117mm Front motor position)

BEARING OIL (HUDY #106230)

NOTE ORIENTATION

BEARING OIL (HUDY #106230)

(65mm Front motor position)

#365101 XRAY XB4 ACTIVE DIFFERENTIAL - CENTER - SET
OPTION

ACTIVE DIFF SEGMENTS			
#325123	60°		OPTION
#325125	90°		INCLUDED
#325127	120°		OPTION

#365438 CENTRAL DOGBONE DRIVE SHAFT 75mm (75mm) Central dogbone drive shafts for REAR MOTOR POSITION

#365437 CENTRAL DOGBONE DRIVE SHAFT 107mm (107mm)

#365437 CENTRAL DOGBONE DRIVE SHAFT 113mm Central dogbone drive shafts for SHORT TRANSMISSION POSITION

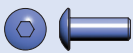

7x 902308
SH M3x8

3x8mm

3x8mm

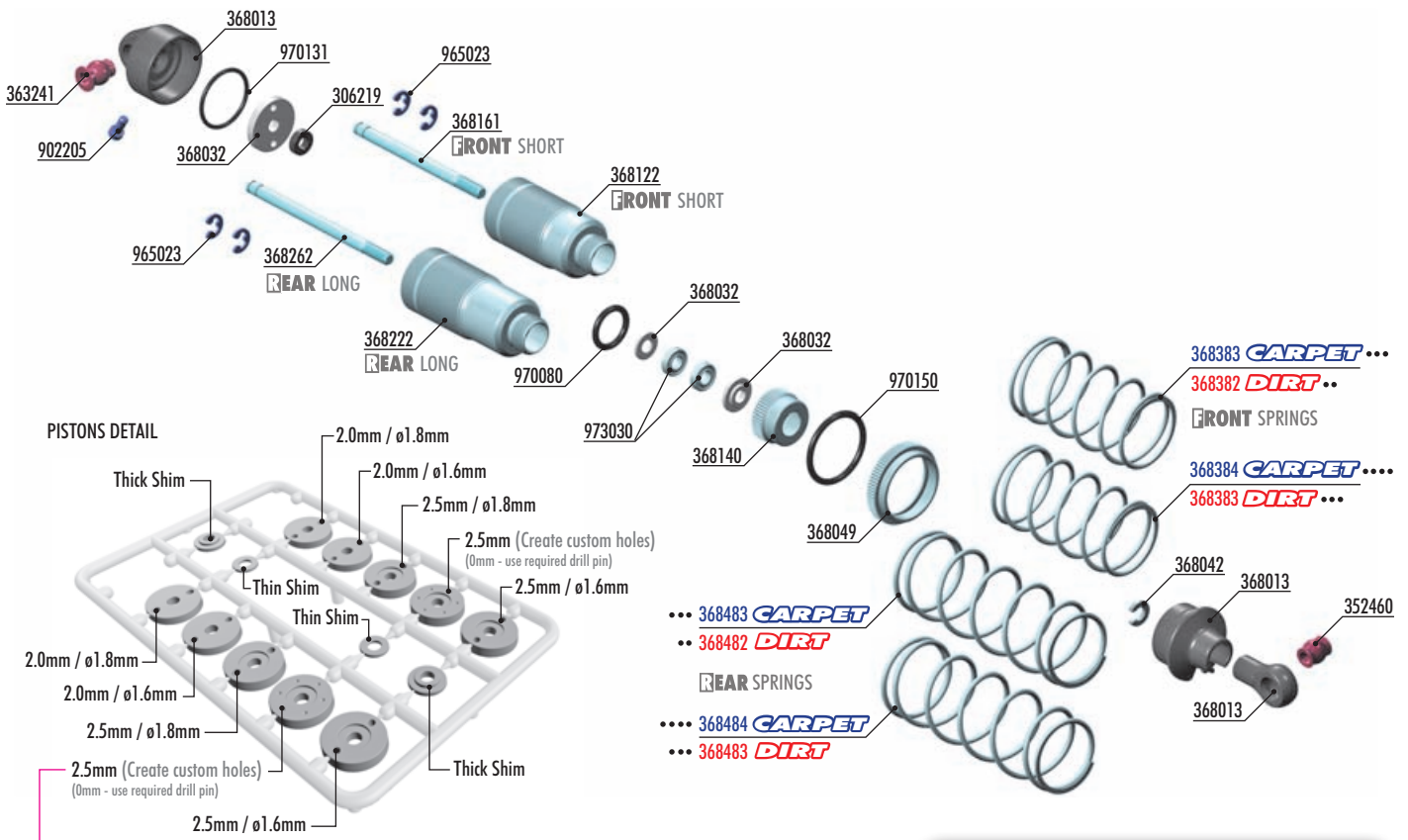

! These pistons can NOT be used in shocks without making the custom holes by yourselves.

#368033
PRECISION GROUND SHOCK PISTON BLANKS 2.5MM - BIG BORE (4)

#368034 PRECISION GROUND SHOCK PISTON BLANKS 2.0MM - BIG BORE (4)

#104004
HUDY AIR VAC - VACUUM PUMP - 1/10 OFF-ROAD

#368054 ALU SHOCK CAP-NUT - BIG BORE (2)

#368021 ALU SHOCK SPRING RETAINING COLLAR (4)

#368022 ALU SHOCK SPRING RETAINING COLLAR - 2mm (4)

#368023 ALU SHOCK SPRING RETAINING COLLAR - 4mm (4)

BAG
07

- 306219 COMPOSITE SET OF SERVO SHIMS (4)
- 352460 PIVOT BALL 5.8 (10)
- 363241 BALL UNIVERSAL 5.8mm WITH BACKSTOP (2)
- 368013 COMPOSITE SHOCK PARTS FOR 2 SHOCKS - BIG BORE
- 368032 SHOCK PISTONS - COMPLETE SET - DELRIN - BIG BORE
- 368049 ALU SHOCK ADJUSTABLE NUT - BIG BORE (2)
- 368042 COMPOSITE SHOCK BUSHING & SHIM (2+2)
- 368101 FRONT SHOCK ABSORBERS - BIG BORE - SET (2)
- 368122 ALU FRONT SHOCK BODY - BIG BORE (2)
- 368140 ALU LOWER SHOCK BODY CAP (2)
- 368161 FRONT HARDENED SHOCK SHAFT 42mm (2)
- 368201 REAR SHOCK ABSORBERS - BIG BORE - SET (2)
- 368222 ALU REAR SHOCK BODY - BIG BORE (2)
- 368262 REAR HARDENED SHOCK SHAFT 47mm (2)
- 902205 HEX SCREW SH M2x5 (10)

- 965023 E-CLIP 2.3 (10)
- 970080 O-RING 8x1 (10)
- 970131 O-RING 13 x 1.0 (10)
- 970150 O-RING 15 x 1.5 (10)
- 973030 SILICONE X-RING PRE-OILED 3x2 (10)

CARPET

- 368383 FRONT CONICAL SPRING-SET L=42.5mm - 3 DOTS (2)
- 368384 FRONT CONICAL SPRING-SET L=42.5mm - 4 DOTS (2)
- 368483 REAR CONICAL SPRING-SET L=57.5mm - 3 DOTS (2)
- 368484 REAR CONICAL SPRING-SET L=57.5mm - 4 DOTS (2)

DIRT

- 368382 FRONT CONICAL SPRING-SET L=42.5mm - 2 DOTS (2)
- 368383 FRONT CONICAL SPRING-SET L=42.5mm - 3 DOTS (2)
- 368482 REAR CONICAL SPRING-SET L=57.5mm - 2 DOTS (2)
- 368483 REAR CONICAL SPRING-SET L=57.5mm - 3 DOTS (2)

OPTION	FRONT SPRINGS	Dots	
#368381	L=42.5mm	•	OPTION
#368382	L=42.5mm	••	INCLUDED
#368383	L=42.5mm	•••	INCLUDED
#368383	L=42.5mm	••••	INCLUDED
#368384	L=42.5mm	•••••	INCLUDED
#368385	L=42.5mm	••••••	OPTION

OPTION	REAR SPRINGS	Dots	
#368481	L=57.5mm	•	OPTION
#368482	L=57.5mm	••	INCLUDED
#368483	L=57.5mm	•••	INCLUDED
#368483	L=57.5mm	••••	INCLUDED
#368484	L=57.5mm	•••••	INCLUDED
#368485	L=57.5mm	••••••	OPTION

#368011 COMPOSITE SHOCK BALL JOINT + 2mm & + 4mm (2+2)

OPTION

8x 965023
C2.3

SET-UP BOOK

SHOCK DAMPING SHOCK PISTONS

PISTONS ALTERNATIVE 1

We recommend for these types of surfaces and traction levels:
CARPET •

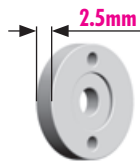

FRONT

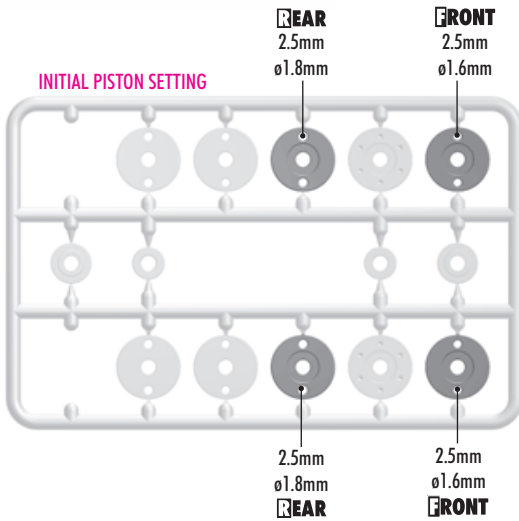
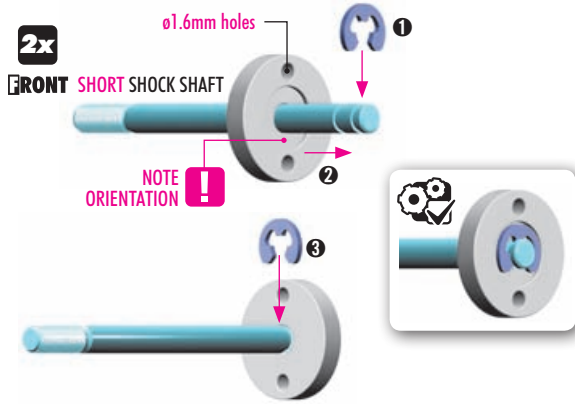

REAR

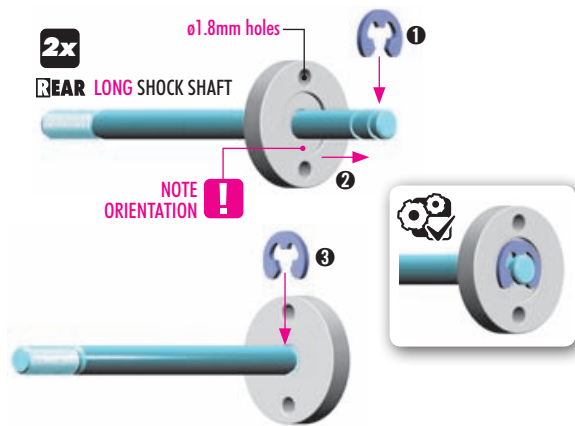

#368033
PRECISION GROUND SHOCK PISTON BLANKS 2.5MM - BIG BORE (4)
OPTION



Use drill bits to create your own piston holes

PISTONS ALTERNATIVE 2

We recommend for these types of surfaces and traction levels:
• ASTRO
• DIRT

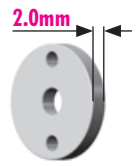

FRONT

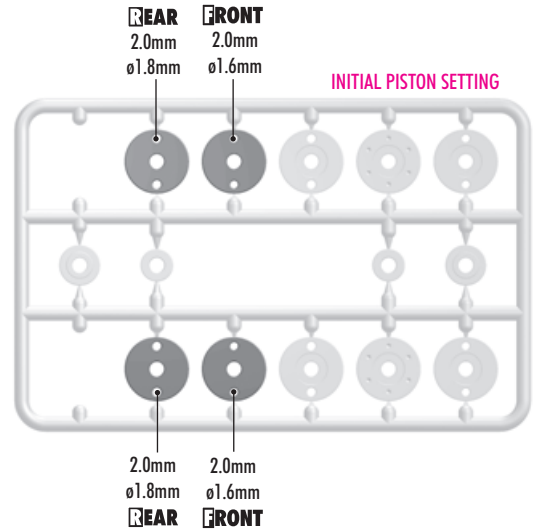
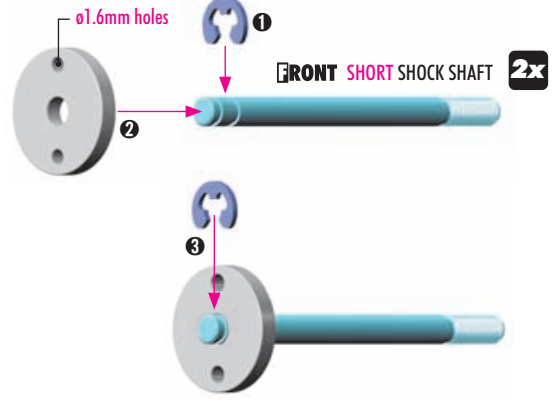

REAR

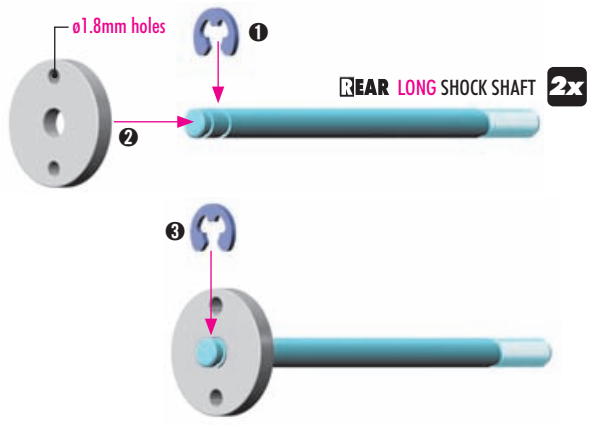

#368034
PRECISION GROUND SHOCK PISTON BLANKS 2.0MM - BIG BORE (4)
OPTION



7. SHOCK ABSORBERS

CARPET DIRT



There are two different thickness shims, use them as shown. Use the same procedure when building both front and rear shocks.

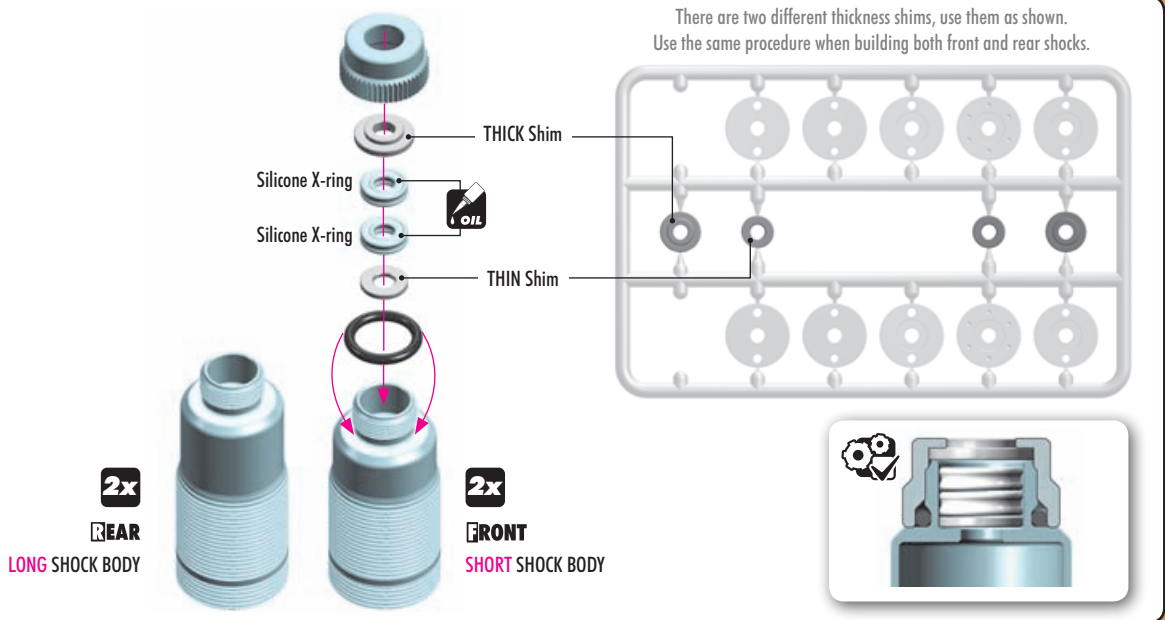

#306219 DOWNSTOP SHIMS
Add downstop shims to limit suspension travel. Thicker shims increase downstop and reduce droop. Thicker downstop shims reduce suspension travel.

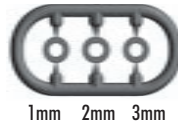

! IMPORTANT
Always use same shim thickness on right and left side to achieve same downstop.

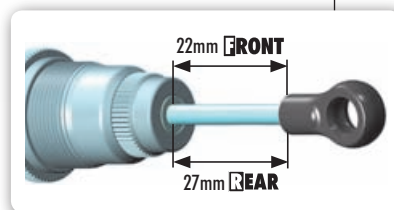
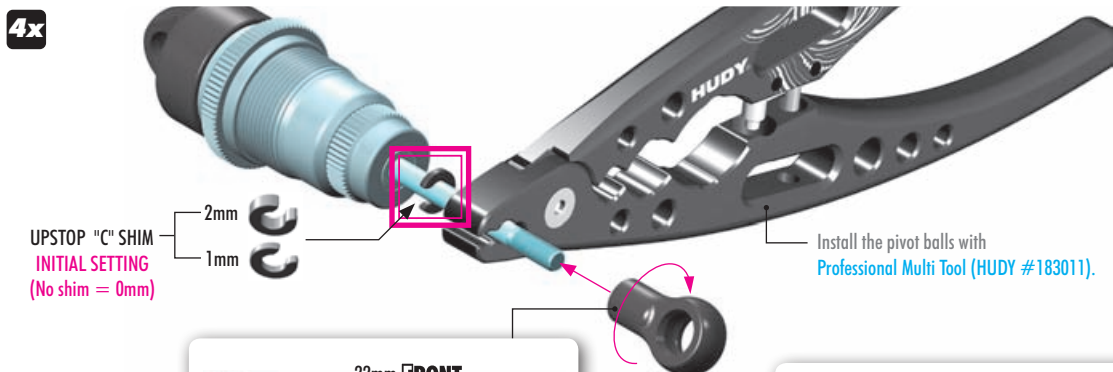
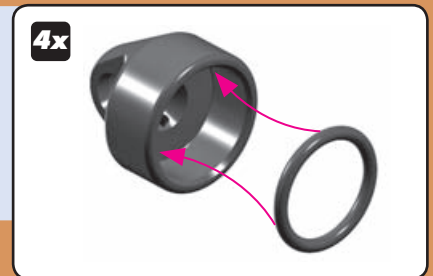
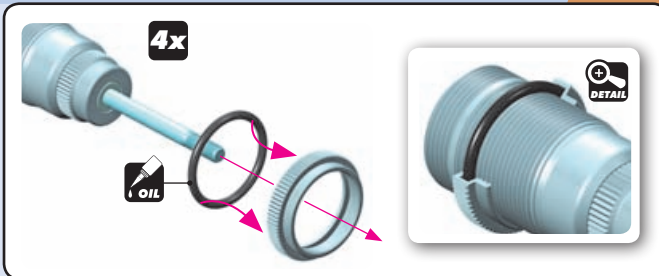
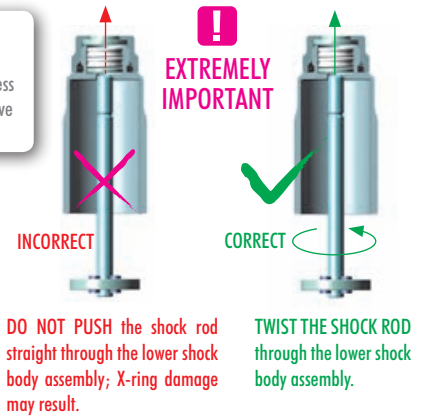
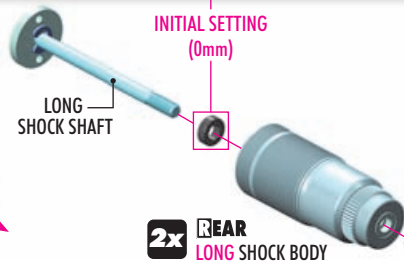
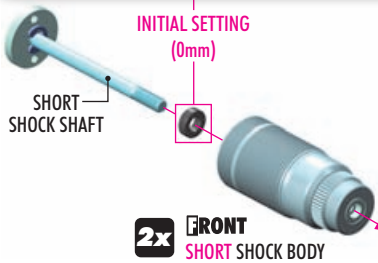



CARPET
Front (short)
Oil 550cSt
Rear (long)
Oil 400cSt

ASTRO
Front (short)
Oil 400cSt
Rear (long)
Oil 300cSt



DIRT
• DIRT
• ASTRO
Front (short)
Oil 400cSt
Rear (long)
Oil 300cSt

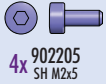

SET-UP BOOK
SHOCK OIL

DEFAULT SHOCK REBOUND SETTING 0% REBOUND

Follow the steps below to set the shock rebound to the default setting of 0%.

- Extend the shock shaft completely. Fill the shock body with the shock oil.
- Move the shock shaft up and down a few times to release the air bubbles trapped beneath the piston. **3~5x UP & DOWN**
- Orient the filled shock vertically for several minutes with the shock shaft fully extended. The remaining air bubbles will release.
- TIGHTEN FULLY. Gently place the shock cap onto the filled shock body and start to tighten the cap. Tighten the cap fully.
- Gently push the shock shaft completely into the shock body. Excess oil will flow through the hole in the shock cap.
- Keep the shock shaft pushed in the shock body and insert the screw into the shock cap. Tighten gently.
- 6x push the shaft up and down. **6x UP & DOWN**
- Untighten the screw.
- Gently push the shock shaft completely into the shock body. Excess oil will flow through the hole in the shock cap.
- Tighten the screw. The rebound will be at approx. 0%.

SHORT FRONT SHOCKS **2x** Short Springs **2x** LONG REAR SHOCKS Long Springs

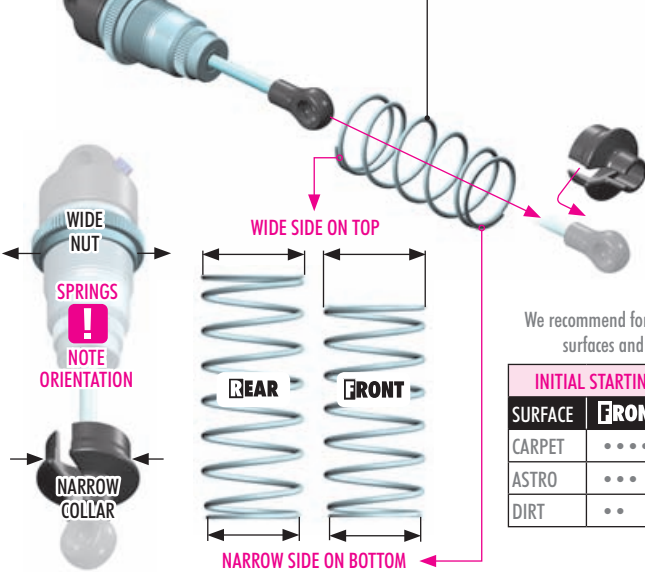

- #368021 ALU SHOCK SPRING RETAINING COLLAR (4) OPTION
 - #368022 ALU SHOCK SPRING RETAINING COLLAR -2mm (4) OPTION
 - #368023 ALU SHOCK SPRING RETAINING COLLAR -4mm (4) OPTION
-

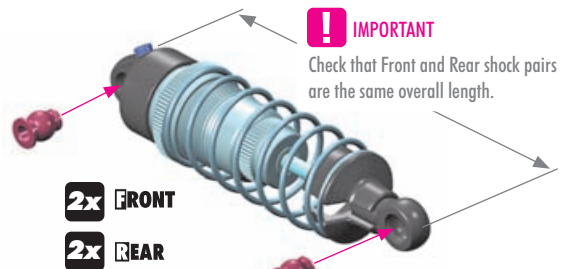

8. FINAL ASSEMBLY

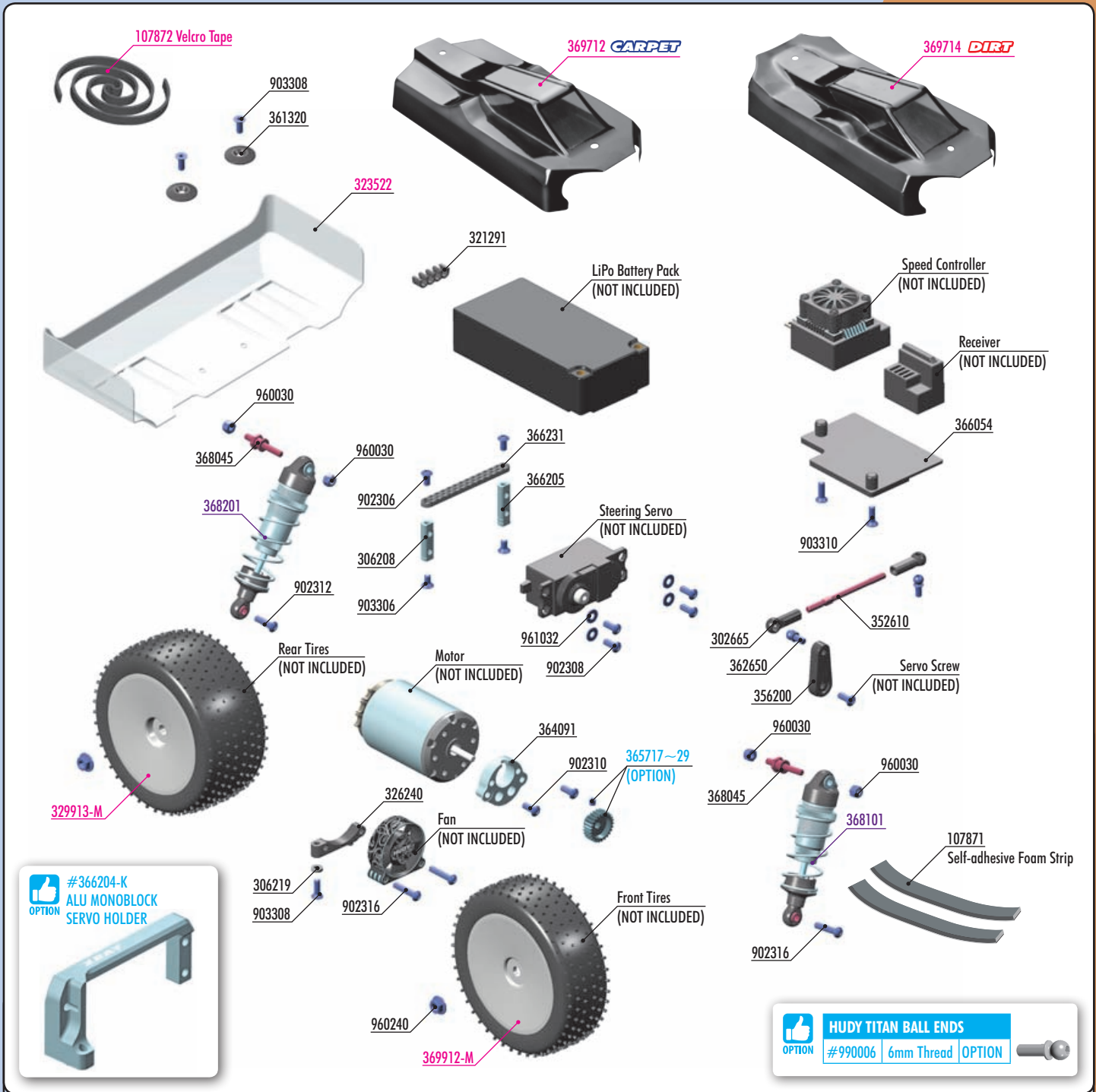

#366204-K
ALU MONOBLOCK
SERVO HOLDER
OPTION

HUDY TITAN BALL ENDS
#990006 6mm Thread OPTION

BAG
08

- | | | | |
|--------|---|----------|--|
| 107871 | HUDY SELF-ADHESIVE FOAM STRIP (2) | 903306 | HEX SCREW SFH M3x6 (10) |
| 302665 | COMPOSITE BALL JOINT 4.9MM - CLOSED WITH HOLE (4) | 903308 | HEX SCREW SFH M3x8 (10) |
| 306208 | ALU SERVO MOUNT 21MM - BOTH SIDES THREADED | 903310 | HEX SCREW SFH M3x10 (10) |
| 306219 | COMPOSITE SET OF SERVO SHIMS (4) | 960030 | NUT M3 (10) |
| 321291 | COMPOSITE 5-WIRES HOLDER - SET | 961032 | WASHER S 3.2 (10) |
| 326240 | COMPOSITE FAN HOLDER | 960240 | NUT M4 WITH SERRATED FLANGE (10) |
| 352610 | ADJ. TURNBUCKLE M3 L/R 45 MM - SPRING STEEL™ (2) | | |
| 356200 | BRAKE/THROTTLE ARMS & STEERING SERVO ARMS - SET | 368101 | FRONT SHOCK ABSORBERS - BIG BORE - SET (2) |
| 361320 | BODY MOUNT, BATTERY MOUNT - V2 & WING SHIM (2) | 368201 | REAR SHOCK ABSORBERS - BIG BORE - SET (2) |
| 362650 | BALL END 4.9MM WITH THREAD 6MM (2) | | |
| 364091 | ALU ECCENTRIC INSERT FOR NARROW MOTOR BULKHEAD | 107872 | VELCRO TAPE WITH DOUBLE SIDED TAPE 8x500MM |
| 366054 | COMPOSITE RADIO PLATE - SHORT | 323522 | LEXAN REAR WING - LUSH |
| 366205 | ALU SERVO MOUNT 22MM - BOTH SIDES THREADED | 329913-M | REAR WHEEL AERODISK WITH 12MM HEX IFMAR - WHITE (2) |
| 366231 | GRAPHITE SERVO HOLDER 2.2MM | 369912-M | FRONT WHEEL AERODISK WITH 12MM HEX IFMAR - WHITE (2) |
| 368045 | STEEL SCREW SHOCK PIVOT BALL WITH HEX (2) | | |
| | | | |
| 902306 | HEX SCREW SH M3x6 (10) | | |
| 902308 | HEX SCREW SH M3x8 (10) | | |
| 902310 | HEX SCREW SH M3x10 (10) | | |
| 902312 | HEX SCREW SH M3x12 (10) | | |
| 902316 | HEX SCREW SH M3x16 (10) | | |

CARPET
369712 BODY FOR 1/10 4WD OFF-ROAD BUGGY - DELTA 4C

DIRT
369714 BODY FOR 1/10 4WD OFF-ROAD BUGGY - DELTA 4D

8. FINAL ASSEMBLY

CARPET **DIRT**

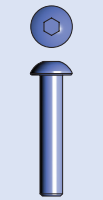

2x 902316 SH M3x16



4x 960030 N M3

NOTE ORIENTATION
L=R

INITIAL POSITION

INITIAL POSITION

DETAIL

DETAIL

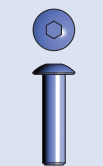
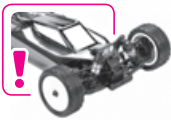

2x 902312 SH M3x12



4x 960030 N M3

NOTE ORIENTATION
L=R

INITIAL POSITION

INITIAL POSITION

DETAIL

DETAIL



OPTION	ALU NUTS M3		
	#296530-B	BLUE	OPTION
	#296530-K	BLACK	OPTION
	#296530-O	ORANGE	OPTION
	#960031	SILVER	OPTION

SERVO LINK
Adjust servo link to fit your servo.

RIGHT THREAD
LEFT THREAD
6mm THREAD

TIP Install the pivot balls with Professional Multi Tool (HUDY #183011).

INITIAL SETTING
CARPET DIRT

28mm

OPTION **HUDY TITAN BALL ENDS**
#990006 6mm Thread **OPTION**

- 2x 902306 SH M3x6
- 4x 902308 SH M3x8
- 4x 961032 SHIM S 3.2

NOTE ORIENTATION

3x6mm
Long
Short
Servo (NOT INCLUDED)
3x8mm
NOTE ORIENTATION
Servo screw (NOT INCLUDED)

OPTION **HUDY ALU SERVO HORNS**

#293497	23T
#293498	24T
#293499	25T

OPTION **HUDY CLAMP ALU SERVO HORNS**

#293404	23T
#293405	24T
#293406	25T

For more in-corner steering and better steering response, aluminum servo horns may be used.

USE APPROPRIATE SERVO ARM:

K (23T) **H** (24T) **F** (25T)

- 2x 903306 SFH M3x6

OPTION **#366204-K ALU MONOBLOCK SERVO HOLDER**



2x 902310
SH M3x10

Motor (NOT INCLUDED)

NOTE ORIENTATION

Pinion (NOT INCLUDED)

Loosen the screw. 1

Insert motor into the bulkhead. 2

PINIONS (48P)		
#294017	17T	
#305918	18T	
#305919	19T	
#294020	20T	
#294021	21T	
#294022	22T	
#294023	23T	
#305924	24T	
#305925	25T	
#365726	26T	
#365727	27T	
#365728	28T	
#365729	29T	

GEARING CHART		
SPUR GEAR	PINION MIN.	PINION MAX.
72T	17T	29T
75T	17T	26T
78T	17T	23T
81T	17T	20T

Final Drive Ratio

$$81 : X \times 2.5 = \text{FDR}$$

(Spur) (Pinion) (IGR)

GEAR MESH

Note orientation of the motor soldering tabs to install cables as low as possible.

- 1 Adjust gear mesh.
- 2 Tighten the screw.
- 3 Check the gear mesh again.
- 4 Redo if necessary.

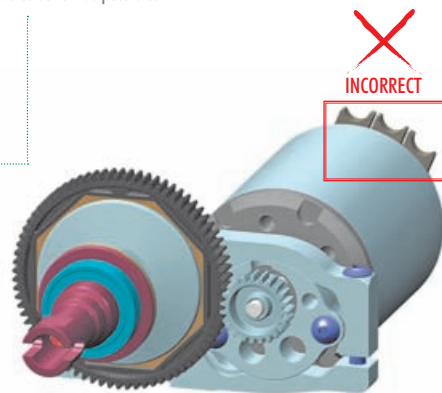
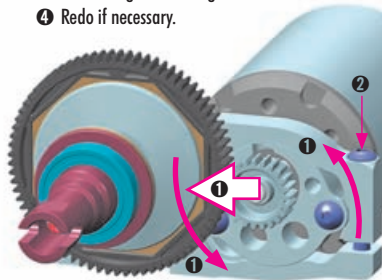

Adjust the motor so the pinion meshes with the spur gear properly. Make sure the gear mesh is not too tight.

There should be a small amount of play between the teeth of the pinion gear and the spur gear.

1x 306219 SHIM 3x6x2



2x 902316 SH M3x16



1x 903308 SFH M3x8



2x 903310 SFH M3x10



FRONT

Speed Controller (NOT INCLUDED)

OPTION #107876 HUDY ULTRA THIN DOUBLE-SIDED TAPE - SINGLE STRIP (5)

OPTION #107875 DOUBLE-SIDED TAPE



OPTION #293101 HUDY ALU RC FAN 30MM SIDE MOUNT 2 HOLE



OPTION #293100 HUDY ALU RC FAN 30MM BOTTOM MOUNT 2 HOLE



OPTION #293110 HUDY BRUSHLESS RC FAN 30MM WITH EXTERNAL SOLDERING TABS

OPTION #293112 HUDY BRUSHLESS RC FAN 30MM WITH INTERNAL SOLDERING TABS



BAG 07

2mm shim use from

3x10mm

3x8mm

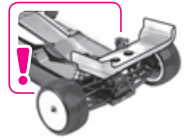

OPTION #293081 HUDY PURE TUNGSTEN WEIGHT 5g



OPTION #293082 HUDY PURE TUNGSTEN WEIGHT 10g



OPTION #293083 HUDY PURE TUNGSTEN WEIGHT 15g

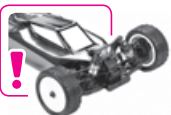

Receiver (NOT INCLUDED)

OPTION #107876 HUDY ULTRA THIN DOUBLE-SIDED TAPE - SINGLE STRIP (5)

OPTION #107875 DOUBLE-SIDED TAPE



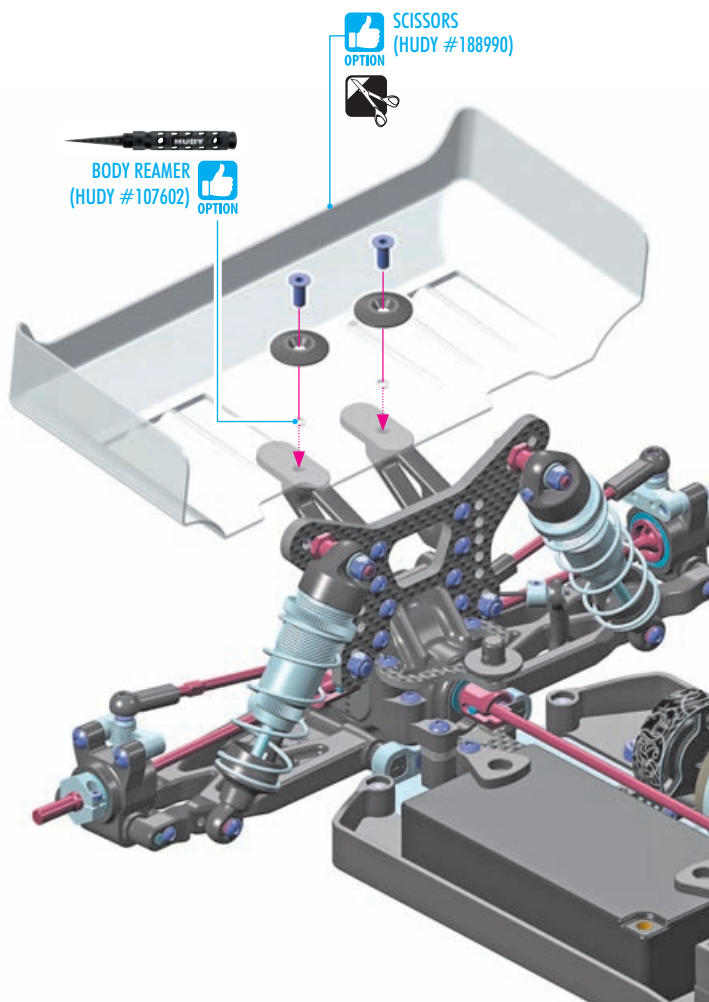
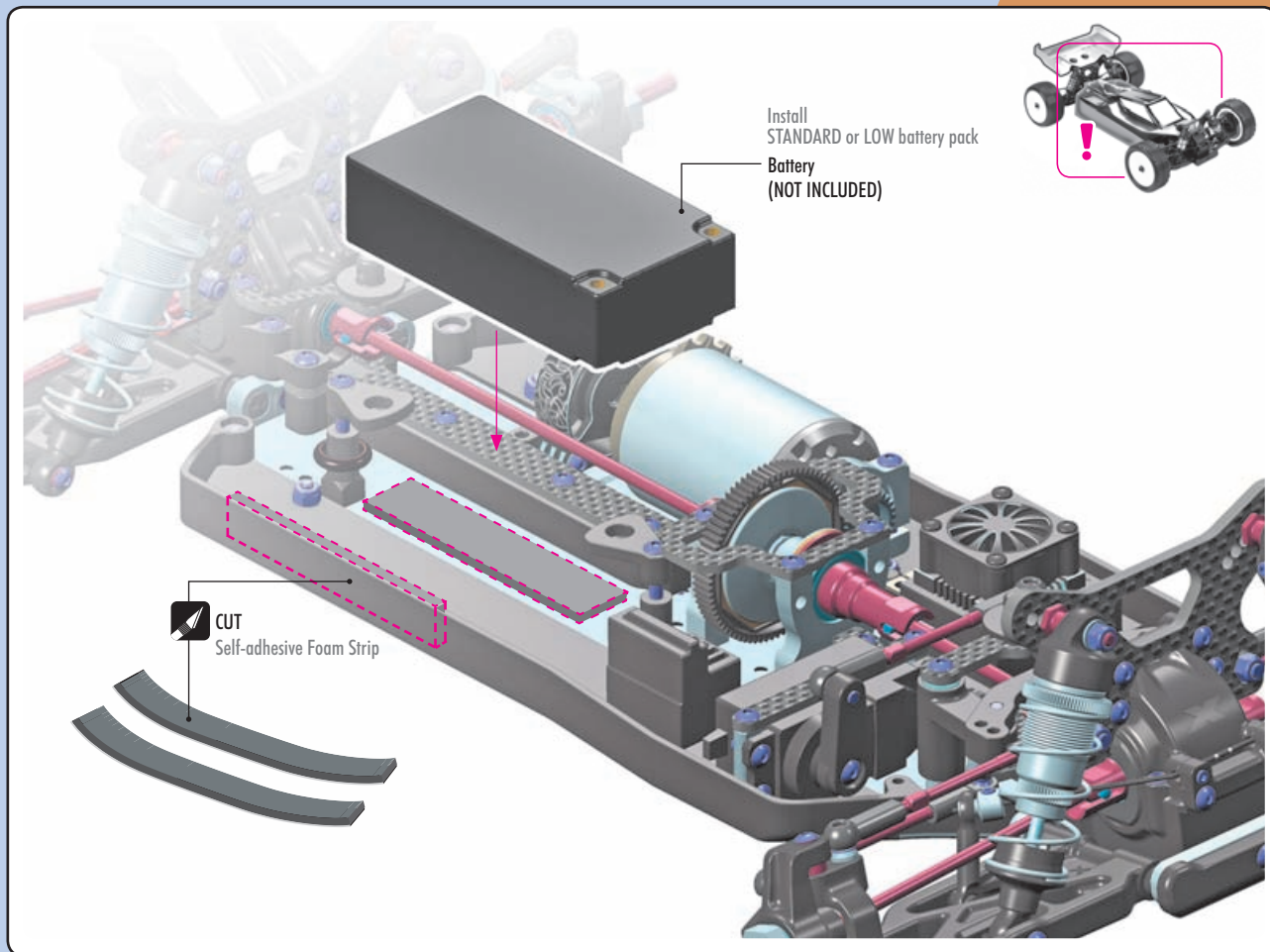

OPTION

REAR WING SHIMS			
#293561	SILVER	OPTION	
#293561-O	ORANGE	OPTION	
#293561-K	BLACK	OPTION	

OPTION

XRAY LEXAN REAR WINGS			
#323510	1.0mm		OPTION
#323511	1.5mm		OPTION
#323513	1.0mm	RANK	OPTION
#323517	1.0mm	TEC	OPTION
#323522	Std.	LUSH	INCLUDED
#323523	Thick	LUSH	OPTION
#363510	1.0mm		OPTION
#363511	1.5mm		OPTION
#363512	2.0mm		OPTION

XRAY LEXAN CENTER FIN

#323515	1.0mm	ZAP	OPTION
---------	-------	-----	--------

- ❶ Before cutting and making holes on the BODY, put the unpainted body on the chassis to confirm the mounting position and location for holes and cutouts. Before cutting and making holes on the WING, put the unpainted wing on the wing holders to confirm the mounting position and location for holes and cutouts.
- ❷ Before painting, wash the inside of the body with mild detergent, and then rinse and dry thoroughly.
- ❸ Mask all windows.

- ❹ Apply paint masks as appropriate.
- ❺ Paint the body using paints formulated for polycarbonate bodies.
- ❻ When the paint is dry, remove the masking.
- ❼ Carefully cut out the body using appropriate scissors or cutting tools.
- ❽ When you have finished cutting, peel off the external protective films.

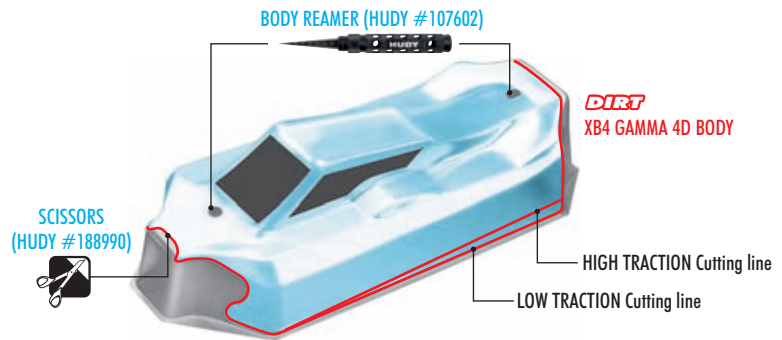
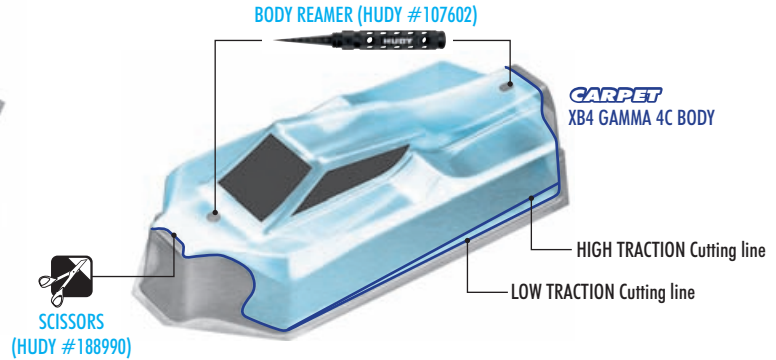
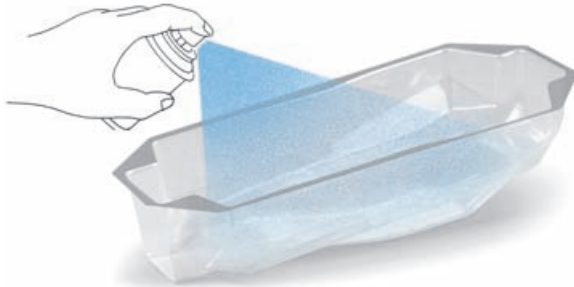

XRAY LEXAN BODY				
OPTION	#369712	0.75mm	DELTA 4C	INCLUDED
	#369713	0.50mm	DELTA 4CL	OPTION
	#369714	0.75mm	DELTA 4D	INCLUDED
	#369715	0.50mm	DELTA 4DL	OPTION

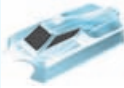

2x **L=R**

Double-sided Velcro™ tape is used to seal the body against the side guards.

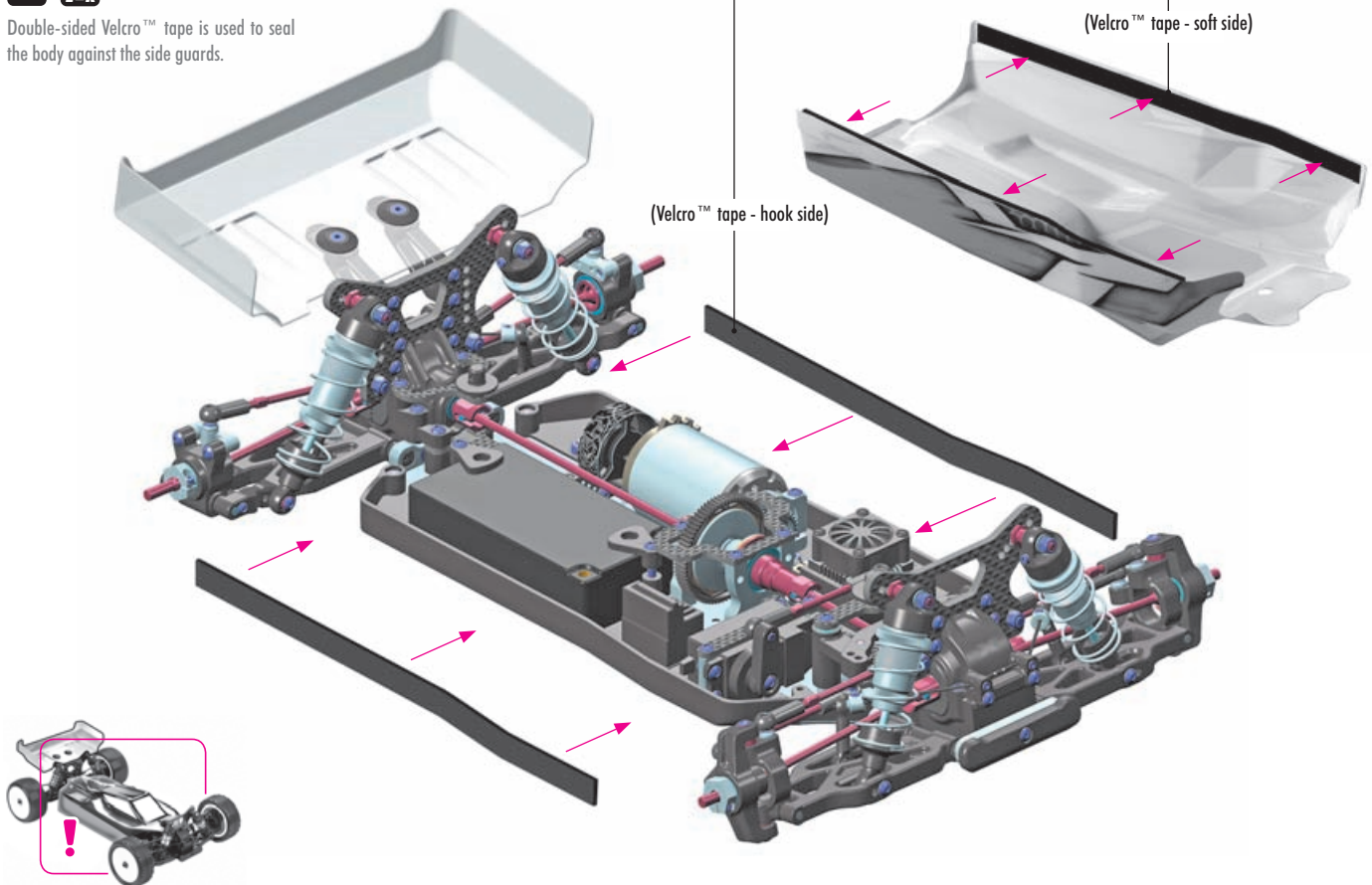

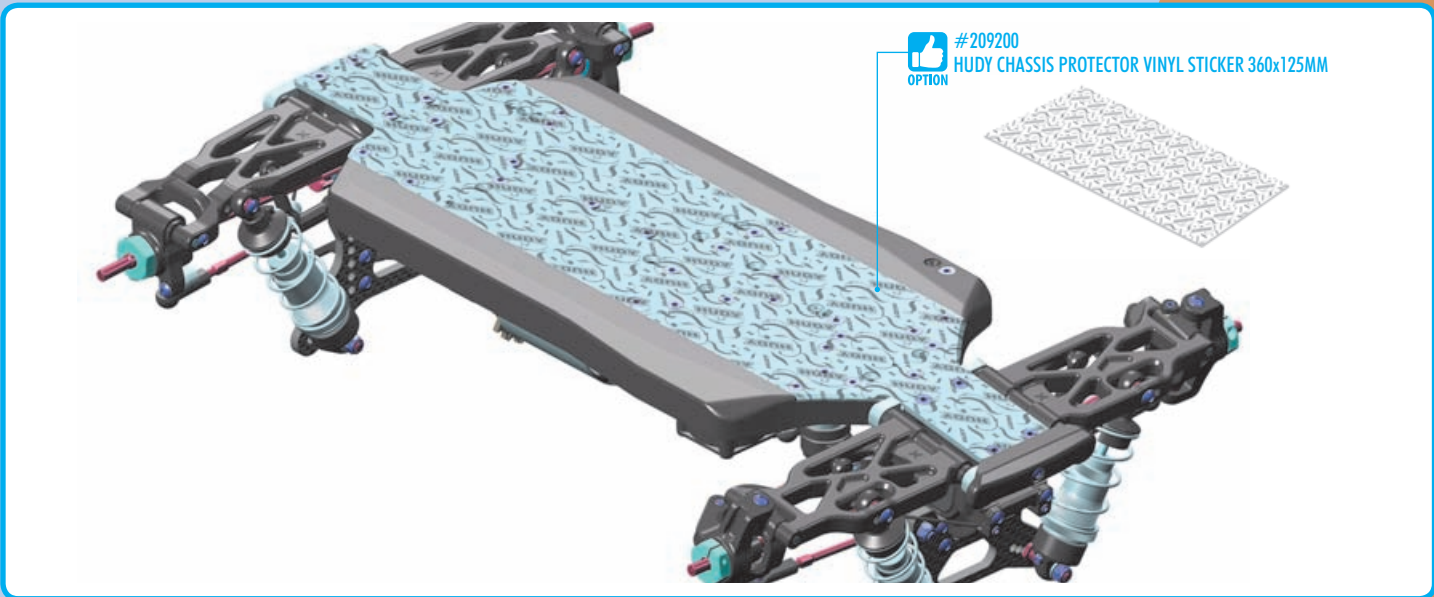

#209200
 HUDY CHASSIS PROTECTOR VINYL STICKER 360x125MM
 OPTION

4x 960240
 N M4

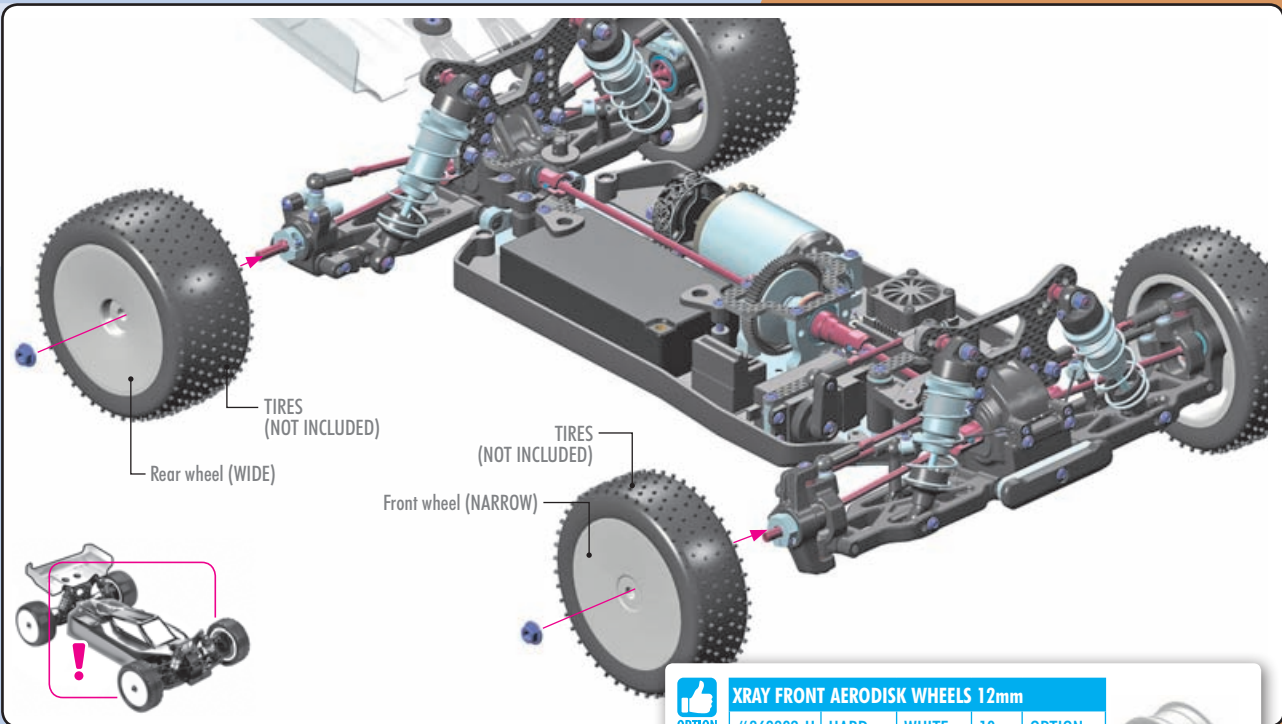

ASSEMBLY VIEW

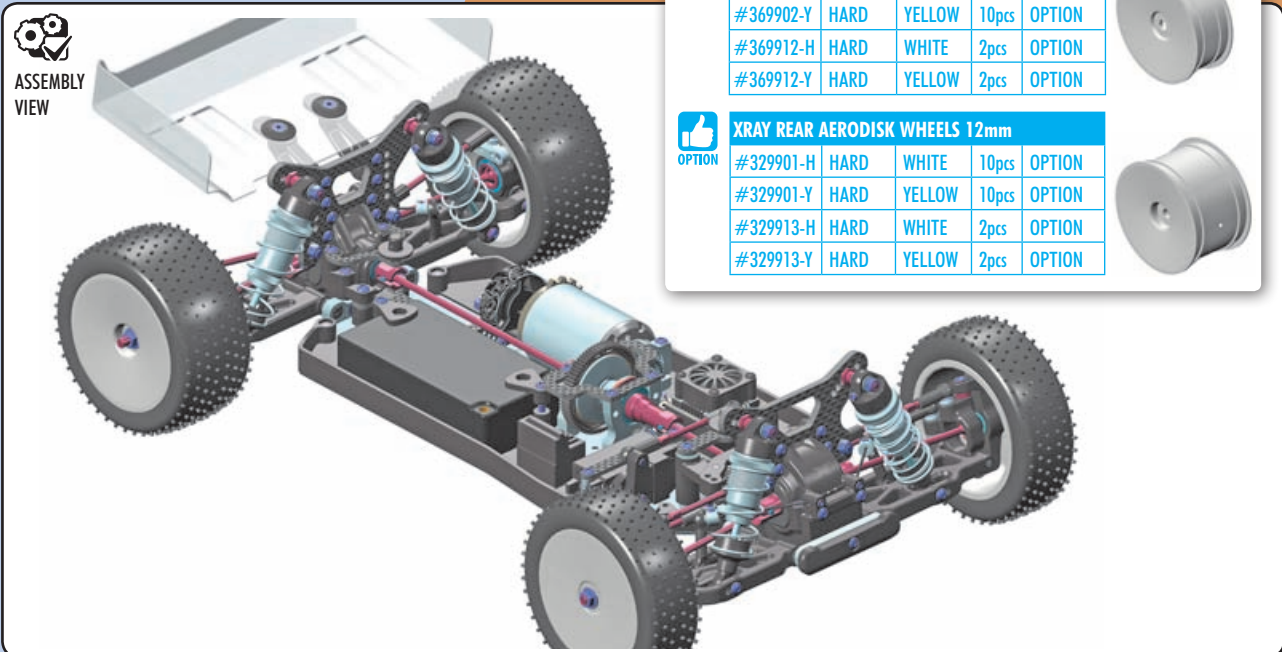

XRAY FRONT AERODISK WHEELS 12mm					
#369902-H	HARD	WHITE	10pcs	OPTION	
#369902-Y	HARD	YELLOW	10pcs	OPTION	
#369912-H	HARD	WHITE	2pcs	OPTION	
#369912-Y	HARD	YELLOW	2pcs	OPTION	

XRAY REAR AERODISK WHEELS 12mm					
#329901-H	HARD	WHITE	10pcs	OPTION	
#329901-Y	HARD	YELLOW	10pcs	OPTION	
#329913-H	HARD	WHITE	2pcs	OPTION	
#329913-Y	HARD	YELLOW	2pcs	OPTION	

SHOCK MAINTENANCE

The most important maintenance task for keeping consistent shock performance is refilling and bleeding them correctly. If built correctly, it will not be necessary to re-build them often. Replacing warped/hard o-rings, scarred piston rods, or shaved/split/loose composite upper and lower ball joints are also important.

- For club racing, it is recommended to check the shocks for air inside before each race and only re-fill and bleed them if necessary. Before each race day, make sure you take the spring off of each shock, hold it up to your ear, and quickly compress the shock rod fully into the body while listening for any air making a "whistling" or "squishy" sound as it passes through the piston holes. If you hear any air, refill and bleed your shocks. For high-competition racing, it is recommended that the shocks be re-filled and bled before a large event.
- If building or pairing new shocks, always make sure they are the same length using a shock length measuring tool and adjust the lower ball joints as needed.
- During regular shock operation, oil naturally gets on the shock shaft and drop-by-drop slightly gets out of the shock body. Shocks should be inspected regularly after each race, and oil replaced as required.

BEARING MAINTENANCE

Ball-bearings in an off-road car must be properly maintained for smooth operation and long lifespan.

The ball-bearings are degreased and are lubricated with HUDY Bearing Oil or HUDY Grease. The following procedures are recommended to clean all of the bearings in your off-road car. For high-competition racing, we recommended doing this every 3-4 weeks, or before a major race.

- 1 Remove the seals on both sides of the bearing (if present). If the seals bend a little and you can see a kink, carefully flatten the kink out by hand.
- 2 Spray the seals with motor cleaner and blow dry with compressed air.
- 3 Spray the bearing on both sides with motor cleaner.
- 4 Spin the bearing while it is still wet to dislodge any particles with the cleaner.
- 5 Spray the bearing on both sides again.
- 6 Blow both sides of the bearing dry with compressed air to make sure particles come out.
- 7 Hold the inner part of the bearing with my left thumb/forefinger and spin it to make sure it spins free without any abnormal vibrations or sounds.
- 8 Place one drop of bearing oil into each side of the bearing.
- 9 Replace both seals at the same time by lining them up on each side of the bearing and lightly pressing them in all the way around the bearings circumference with your thumb and forefinger. DO NOT press too hard or use any type of tool, such as a wrench tip, to push the blue seals in as they will push in too far, bend and cause drag.

If you spin test the bearing after you have re-oiled and sealed it, it will not spin freely for an extended period of time. The lightest of oils may allow it to spin for 1-2 seconds. This is normal and once you have mounted the bearings in the car again, the drive train will spin freely.

Make sure you use a motor cleaner that DOES NOT leave a residue after it dries as this may cause drag and wear in the bearings.

RECOMMENDED PRODUCTS

- Use correct oil or grease to lubricate the bearings:
 #106230 HUDY Bearing Oil
 #106220 HUDY Bearing Grease - Standard
 #106221 HUDY Bearing Grease - Blue
 #106222 HUDY Bearing Grease - Red



SUSPENSION & DRIVETRAIN MAINTENANCE

- Check suspension for free movement during building and operation, and especially after running and if you have crashed the car. If the suspension DOES NOT move freely, use the appropriate HUDY Arm Reamer to clean and resize the holes of the suspension arms.
- Regularly check the drive shaft pins (both side and center) and if they show any wear must be immediately replaced by new pins. If the car is run with worn pins, excessive wear on the diff outdrives will result. The #106000 HUDY Drive Pin Replacement Tool (for 3mm Pins) is a compact, rugged multi-use tool set for replacing 3mm drive pins in drive shafts. Use the HUDY replacement drive shaft pins 3x12 (#106051).
- Regularly inspect and replace the connecting pins which connect the center drive shafts with the pinion gear, and also the pins that connect the wheel drive shafts with wheel axles. Use HUDY Graphite Grease to lubricate the drive shaft connecting joints and the diff gears.
- Pivot balls and ball-joints will naturally wear for some time and will generate play. If there is too much play the pivot balls and ball joints need to be replaced.
- If the car is run in wet conditions, apply WD-40® on all drivetrain parts before the run. After the run, clean and dry the parts again.

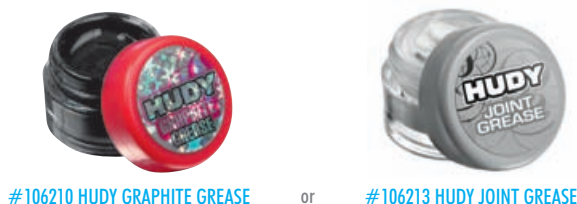

HUDY SPRING STEEL™

The HUDY Spring Steel™ used in the car is the strongest and most durable steel material on the RC market. While items made from HUDY Spring Steel™ are still subject to wear, the lifespan is considerably longer than any other material. As parts made from HUDY Spring Steel™ wear, the

brown color will fade (get lighter) but it will not affect the strength of the material. The brown color is only a surface treatment and if the brown color will wear the durability of the part will be still strong.

EXCLUSIVE PROFESSIONAL

HUDY

108601 - Grey

108603 - Dark Gray

108602 - Silver Gray

108604 - Titan

108605-Black

199183

104004



107701



106000 + 106036



109801



181090



107742



107740



293100

293101

293110

293112



181030



108190

- 104004 HUDY AIR VAC - VACUUM PUMP - 1/10 OFF-ROAD
- 105500 HUDY UNIVERSAL TIRE BALANCING STATION
- 105520 WHEEL ADAPTER FOR 1/10 TOURING CARS - 12MM
- 106000 HUDY DRIVE PIN REPLACEMENT TOOL (FOR 3MM PINS)
- 106036 EJECTOR PIVOT PIN & ALTERNATING PIVOT 2.5MM FOR #106000
- 107090 HUDY BEARING CHECKING TOOL
- 107601 LIMITED EDITION - REAMER FOR BODY 0-9MM + COVER - SMALL
- 107701 CHASSIS DROOP GAUGE SUPPORT BLOCKS 20MM FOR 1/8 - LW(2)
- 107740 HUDY ADJUSTABLE RIDE HEIGHT GAUGE 14-20MM
- 107742 HUDY ADJUSTABLE RIDE HEIGHT GAUGE 20-30MM
- 107855 HUDY PIT LED
- 107880 CHASSIS BALANCING TOOL (2)

- 108160 HUDY 1/10 OFF-ROAD CAR STAND - V2
- 108190 HUDY ALU TRAY FOR PARTS
- 108601 FLAT SET-UP BOARD FOR 1/10 OFF-ROAD - LIGHTWEIGHT - GREY
- 108602 FLAT SET-UP BOARD FOR 1/10 OFF-ROAD - LIGHTWEIGHT - SILVER GRAY
- 108603 FLAT SET-UP BOARD FOR 1/10 OFF-ROAD - LIGHTWEIGHT - DARK GREY
- 108604 FLAT SET-UP BOARD FOR 1/10 OFF-ROAD - LIGHTWEIGHT - TITAN
- 108605 FLAT SET-UP BOARD FOR 1/10 OFF-ROAD - LIGHTWEIGHT - BLACK
- 108901 HUDY SET-UP STATION FOR 1/10 OFF-ROAD CARS
- 108960 ALU NUT FOR 1/10 OFF-ROAD SET-UP SYSTEM (4)
- 109801 HUDY ALU TRAY FOR 1/10 OFF-ROAD DIFF & SHOCKS
- 109840 HUDY ALU TRAY FOR 1/10 OFF-ROAD DIFF ASSEMBLY
- 109860 HUDY ALU TRAY FOR SET-UP SYSTEM

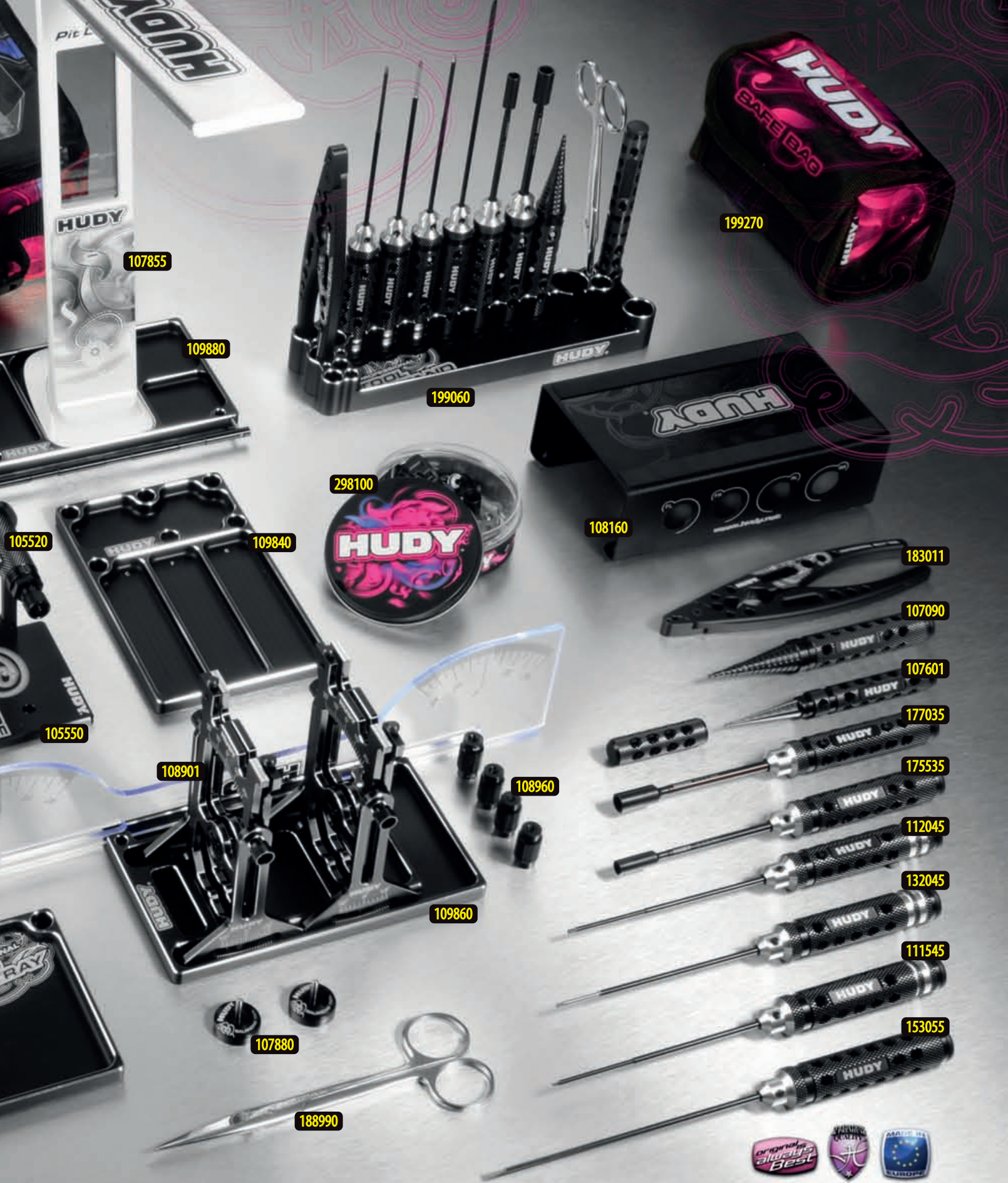

109880 HUDY ALU TRAY FOR ACCESSORIES & PIT LED
 111545 LIMITED EDITION - ALLEN WRENCH # 1.5MM
 112045 LIMITED EDITION - ALLEN WRENCH # 2.0MM
 132045 LIMITED EDITION - ALLEN WRENCH + BALL REPL. TIP # 2.0MM
 153055 LIMITED EDITION - SLOTTED SCREWDRIVER # 3.0MM - LONG
 175535 LIMITED EDITION - SOCKET DRIVER # 5.5MM
 177035 LIMITED EDITION - SOCKET DRIVER # 7.0MM
 181030 HUDY SPRING STEEL TURNBUCKLE WRENCH 3 MM
 181090 HUDY SPECIAL TOOL FOR TURNBUCKLES & NUTS
 183011 HUDY PROFESSIONAL MULTI TOOL

188990 HUDY PROFESSIONAL BODY SCISSORS
 199060 HUDY ALU TOOL STAND
 199183 HUDY CAR BAG - 1/10 OFF-ROAD
 199270 HUDY LIPO SAFETY BAG
 298100 HUDY TIN ROUND BOX 80X30MM
 293100 HUDY ALU RC FAN 30MM - BOTTOM MOUNT 2 HOLE
 293101 HUDY ALU RC FAN 30MM - SIDE MOUNT 2 HOLE
 293110 HUDY BRUSHLESS RC FAN 30MM - WITH EXTERNAL SOLDERING TABS
 293112 HUDY BRUSHLESS RC FAN 30MM - WITH INTERNAL SOLDERING TABS

For more information about tools, set-up equipment and accessories suitable for your car please visit:

www.hudy.net



www.teamxray.com

XRAY EUROPE

XRAY, K VÝSTAVISKU 6992, 91101 TRENCIN, SLOVAKIA, EUROPE
PHONE: +421-32-740 11 00, FAX: +421-32-740 11 09, info@teamxray.com

XRAY USA

RC AMERICA, 2030 Century Center Blvd #15, Irving, TX 75062, USA
PHONE: 214-744-2400, FAX: 214-744-2401, xray@rcamerica.com



/TeamXray



/TeamXray



/TeamXray



/TeamXrayRC



/XrayRacing



/XrayRacing