

1/10 LUXURY ELECTRIC OFF-ROAD BUGGY 4WD

XRAY XB4

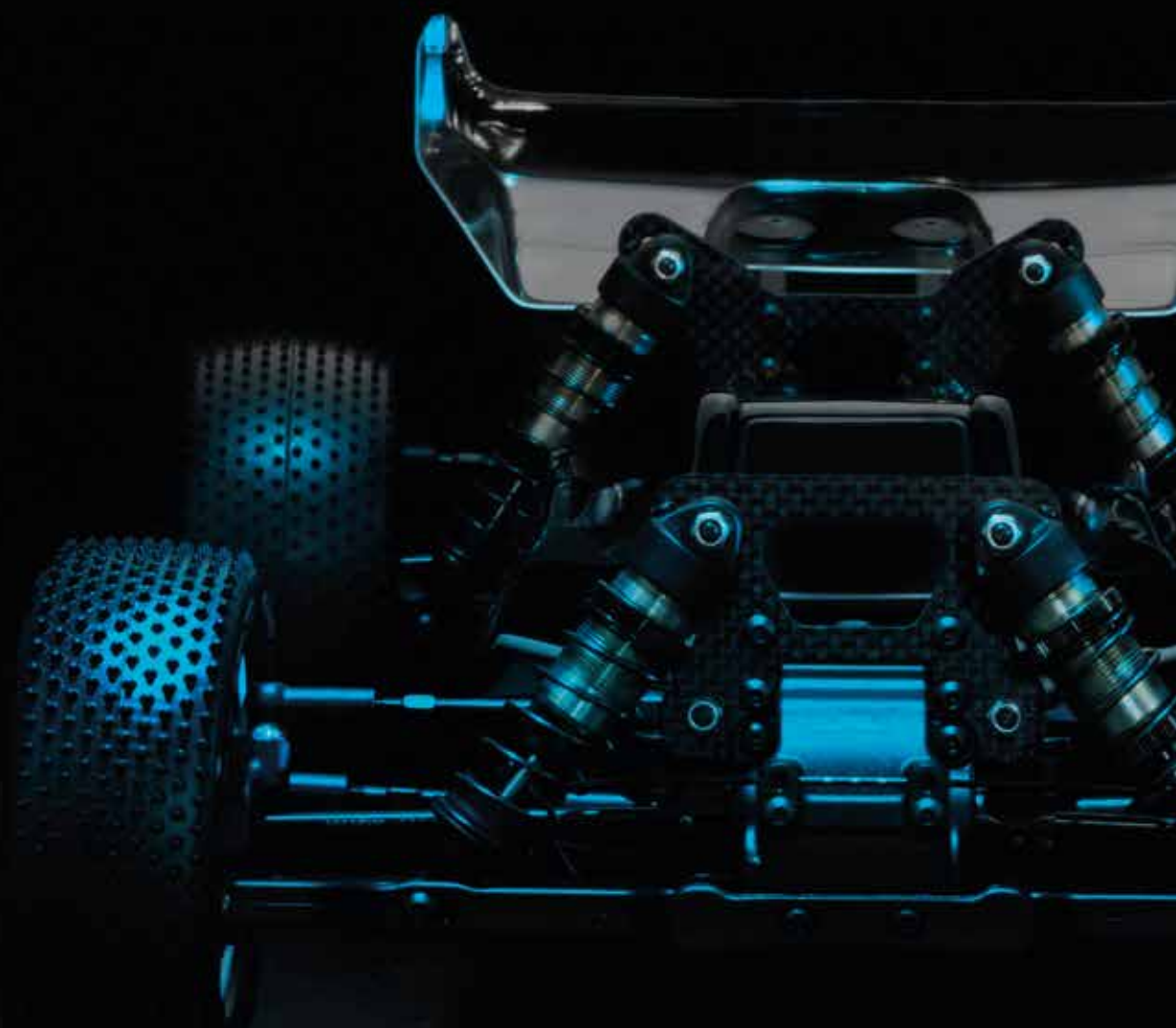

INSTRUCTION MANUAL
FOR XB4C'22 & XB4D'22 EDITION

BEFORE YOU START

This is a high-competition, high-quality RC car intended for persons aged 16 years and older with previous experience building and operating RC model racing cars. This is not a toy; it is a precision racing model. This model racing car is not intended for use by beginners, inexperienced customers, or by children without direct supervision of a responsible, knowledgeable adult. If you do not fulfill these requirements, please return the kit in unused and unassembled form back to the shop where you have purchased it.

Before building and operating your XRAY, **YOU MUST** read through all of the operating instructions and instruction manual and fully understand them to get the maximum enjoyment and prevent unnecessary damage.

CUSTOMER SUPPORT

We have made every effort to make these instructions as easy to understand as possible. However, if you have any difficulties, problems, or questions, please do not hesitate to contact the XRAY support team at info@teamxray.com. Also, please visit our Web site at www.teamxray.com to find the latest updates, set-up information, option parts, and many other goodies. We pride ourselves on taking excellent care of our customers.

You can join thousands of XRAY fans and enthusiasts in our online community at: www.teamxray.com

Read carefully and fully understand the instructions before beginning assembly.

Make sure you review this entire manual, download and use set-up book from the web, and examine all details carefully. If for some reason you decide this is not what you wanted or expected, do not continue any further. Your hobby dealer can not accept your kit for return or exchange after it has been partially or fully assembled.

Contents of the box may differ from pictures. In line with our policy of continuous product development, the exact specifications of the kit may vary without prior notice.

XRAY Europe

K Vystavisku 6992
91101 Trenčín
Slovakia, EUROPE
Phone: 421-32-7401100
Fax: 421-32-7401109
E-mail: info@teamxray.com

XRAY USA

RC America, 2030 Century Center Blvd #15
Irving, TX 75062
USA
Phone: (214) 744-2400
Fax: (214) 744-2401
E-mail: xray@rcamerica.com

FAILURE TO FOLLOW THESE INSTRUCTIONS WILL BE CONSIDERED AS ABUSE AND/OR NEGLECT.

SAFETY PRECAUTIONS

Contains:

LEAD (CAS 7439-92-1) ANTIMONY (CAS 7440-36-0)

WARNING: This product contains a chemical known to the state of California to cause cancer and birth defects or other reproductive harm.

CAUTION: CANCER HAZARD

Contains lead, a listed carcinogen. Lead is harmful if ingested. Wash thoroughly after using. DO NOT use product while eating, drinking or using tobacco products. May cause chronic effects to gastrointestinal tract, CNS, kidneys, and blood. **MAY CAUSE BIRTH DEFECTS.**

When building, using and/or operating this model always wear protective glasses and gloves.

Take appropriate safety precautions prior to operating this model. You are responsible for this model's assembly and safe operation! Please read the instruction manual before building and operating this model and follow all safety precautions. Always keep the instruction manual at hand for quick

reference, even after completing the assembly. Use only genuine and original authentic XRAY parts for maximum performance. Using any third party parts on this model will void guaranty immediately.

Improper operation may cause personal and/or property damage. XRAY and its distributors have no control over damage resulting from shipping, improper construction, or improper usage. XRAY assumes and accepts no responsibility for personal and/or property damages resulting from the use of improper building materials, equipment and operations. By purchasing any item produced by XRAY, the buyer expressly warrants that he/she is in compliance with all applicable federal, state and local laws and regulation regarding the purchase, ownership and use of the item. The buyer expressly agrees to indemnify and hold harmless XRAY for all claims resulting directly or indirectly from the purchase, ownership or use of the product. By the act of assembling or operating this product, the user accepts all resulting liability. If the buyer is not prepared to accept this liability, then he/she should return this kit in new, unassembled, and unused condition to the place of purchase.



IMPORTANT NOTES - GENERAL

- This product is not suitable for children under 16 years of age without the direct supervision of a responsible and knowledgeable adult.
- Carefully read all manufacturers warnings and cautions for any parts used in the construction and use of your model.
- Assemble this kit only in places away from the reach of very small children.
- First-time builders and users should seek advice from people who have building experience in order to assemble the model correctly and to allow the model to reach its performance potential.
- Exercise care when using tools and sharp instruments.
- Take care when building, as some parts may have sharp edges.
- Keep small parts out of reach of small children. Children must not be allowed to put any parts in their mouth, or pull vinyl bag over their head.
- Read and follow instructions supplied with paints and/or cement, if used (not included in kit).
- Immediately after using your model, do NOT touch equipment on the model such as the motor and speed controller, because they generate high temperatures. You may seriously burn yourself seriously touching them.
- Follow the operating instructions for the radio equipment at all times.
- Do not put fingers or any objects inside rotating and moving parts, as this may cause damage or serious injury as your finger, hair, clothes, etc. may get caught.
- Be sure that your operating frequency is clear before turning on or running your model, and never share the same frequency with somebody else at the same time. Ensure that others are aware of the operating frequency you are using and when you are using it.
- Use a transmitter designed for ground use with RC cars. Make sure that no one else is using the same frequency as yours in your operating area. Using the same frequency at the same time, whether it is driving, flying or sailing, can cause loss of control of the RC model, resulting in a serious accident.
- Always turn on your transmitter before you turn on the receiver in the car. Always turn off the receiver before turning your transmitter off.
- Keep the wheels of the model off the ground when checking the operation of the radio equipment.
- Disconnect the battery pack before storing your model.
- When learning to operate your model, go to an area that has no obstacles that can damage your model if your model suffers a collision.
- Remove any sand, mud, dirt, grass or water before putting your model away.
- If the model behaves strangely, immediately stop the model, check and clear the problem.
- To prevent any serious personal injury and/or damage to property, be responsible when operating all remote controlled models.
- The model car is not intended for use on public places and roads or areas where its operation can conflict with or disrupt pedestrian or vehicular traffic.
- Because the model car is controlled by radio, it is subject to radio interference from many sources that are beyond your control. Since radio interference can cause momentary loss of control, always allow a safety margin in all directions around the model in order to prevent collisions.
- Do not use your model:
 - Near real cars, animals, or people that are unaware that an RC car is being driven.
 - In places where children and people gather
 - In residential districts and parks
 - In limited indoor spaces
 - In wet conditions
 - In the street
 - In areas where loud noises can disturb others, such as hospitals and residential areas.
 - At night or anytime your line of sight to the model may be obstructed or impaired in any way.

To prevent any serious personal injury and/or damage to property, please be responsible when operating all remote controlled models.

IMPORTANT NOTES - ELECTRICAL

- Insulate any exposed electrical wiring (using heat shrink tubing or electrical tape) to prevent dangerous short circuits. Take maximum care in wiring, connecting and insulating cables. Make sure cables are always connected securely. Check connectors for if they become loose. And if so, reconnect them securely. Never use RC models with damaged wires. A damaged wire is extremely dangerous, and can cause short-circuits resulting in fire. Please have wires repaired at your local hobby shop.
- Low battery power will result in loss of control. Loss of control can occur due to a weak battery in either the transmitter or the receiver. Weak running battery may also result in an out of control car if your car's receiver power is supplied by the running battery. Stop operation immediately if the car starts to slow down.
- When not using RC model, always disconnect and remove battery.
- Do not disassemble battery or cut battery cables. If the running battery short-circuits, approximately 300W of electricity can be discharged, leading to fire or burns. Never disassemble battery or cut battery cables.
- Use a recommended charger for the receiver and transmitter batteries and follow the instructions correctly. Over-charging, incorrect charging,

or using inferior chargers can cause the batteries to become dangerously hot. Recharge battery when necessary. Continual recharging may damage battery and, in the worst case, could build up heat leading to fire. If battery becomes extremely hot during recharging, please ask your local hobby shop for check and/or repair and/or replacement.

- Regularly check the charger for potential hazards such as damage to the cable, plug, casing or other defects. Ensure that any damage is rectified before using the charger again. Modifying the charger may cause short-circuit or overcharging leading to a serious accident. Therefore do not modify the charger.
- Always unplug charger when recharging is finished.
- Do not recharge battery while battery is still warm. After use, battery retains heat. Wait until it cools down before charging.
- Do not allow any metal part to short circuit the receiver batteries or other electrical/electronic device on the model.
- Immediately stop running if your RC model gets wet as may cause short circuit.
- Please dispose of batteries responsibly. Never put batteries into fire.

R/C & BUILDING TIPS

- Make sure all fasteners are properly tightened. Check them periodically.
- Make sure that chassis screws do not protrude from the chassis.
- For the best performance, it is very important that great care is taken to ensure the free movement of all parts.
- Clean all ball-bearings so they move very easily and freely.
- Tap or pre-thread the plastic parts when threading screws.
- Self-tapping screws cut threads into the parts when being tightened. Do not use excessive force when tightening the self-tapping screws because you may strip out the thread in the plastic. We recommended you stop tightening a screw when you feel some resistance.
- Ask your local hobby shop for any advice.

Please support your local hobby shop. We at XRAY Model Racing Cars support all local hobby dealers. Therefore we ask you, if at all possible, to purchase XRAY products at your hobby dealer and give them your support like we do. If you have difficulty finding XRAY products, please check out www.teamxray.com to get advice, or contact us via email at info@teamxray.com, or contact the XRAY distributor in your country.

WARRANTY

XRAY guarantees this model kit to be free from defects in both material and workmanship within 30 days of purchase. The total monetary value under warranty will in no case exceed the cost of the original kit purchased. This warranty does not cover any components damaged by use or modification or as a result of wear. Part or parts missing from this kit must be reported within 30 days of purchase. No part or parts will be sent under warranty without proof of purchase. Should you find a defective or missing part, contact the local distributor. Service and customer support will be provided through local hobby store where you have purchased the kit, therefore make sure to purchase any XRAY products at your local hobby store. This model racing car is considered to be a high-performance racing vehicle. As such this vehicle will be used in an extreme range of conditions and situations, all which may cause premature wear or failure of any component. XRAY has no control over usage of vehicles once they leave the dealer, therefore XRAY can only offer warranty against all manufacturer's defects in materials, workmanship, and assembly at point of sale and before use. No warranties are expressed or implied that cover damage caused by what is considered normal use, or cover or imply how long any model cars' components or electronic components will last before requiring replacement.

Due to the high performance level of this model car you will need to periodically maintain and replace consumable components. Any and all warranty coverage will not cover replacement of any part or component damaged by neglect, abuse, or improper or unreasonable use. This includes but is not limited to damage from crashing, chemical and/or water damage, excessive moisture, improper or no maintenance, or user modifications which

compromise the integrity of components. Warranty will not cover components that are considered consumable on RC vehicles. XRAY does not pay nor refund shipping on any component sent to XRAY or its distributors for warranty. XRAY reserves the right to make the final determination of the warranty status of any component or part.

Limitations of Liability

XRAY makes no other warranties expressed or implied. XRAY shall not be liable for any loss, injury or damages, whether direct, indirect, special, incidental, or consequential, arising from the use, misuse, or abuse of this product and/or any product or accessory required to operate this product. In no case shall XRAY's liability exceed the monetary value of this product.

Take adequate safety precautions prior to operating this model. You are responsible for this model's assembly and safe operation.

Disregard of the any of the above cautions may lead to accidents, personal injury, or property damage. XRAY MODEL RACING CARS assumes no responsibility for any injury, damage, or misuse of this product during assembly or operation, nor any additions that may arise from the use of this product.

All rights reserved.

QUALITY CERTIFICATE

XRAY MODEL RACING CARS uses only the highest quality materials, the best compounds for molded parts and the most sophisticated manufacturing processes of TQM (Total Quality Management). We guarantee that all parts of a newly-purchased kit are manufactured with the highest regard to quality. However, due to the many factors inherent in model racecar competition, we

cannot guarantee any parts once you start racing the car. Products which have been worn out, abused, neglected or improperly operated will not be covered under warranty.

We wish you enjoyment of this high-quality and high-performance RC car and wish you best success on the track!

In line with our policy of continuous product development, the exact specifications of the kit may vary. In the unlikely event of any problems with your new kit, you should contact the model shop where you purchased it, quoting the part number.

We do reserve all rights to change any specification without prior notice. All rights reserved.

TOOLS REQUIRED



Combination Pliers
(HUDY #189020)



Side Cutters
(HUDY #189010)



Pocket Hobby Knife (HUDY #188981)



Special Tool for turnbuckles, nuts (HUDY #181090)



Turnbuckle Wrench 3mm (HUDY #181030)

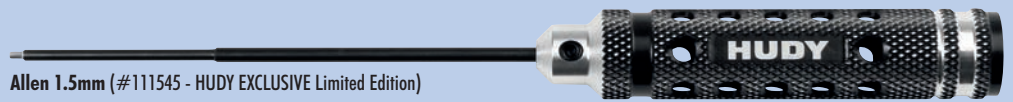

Allen 1.5mm (#111545 - HUDY EXCLUSIVE Limited Edition)



Allen 2.0mm (#112045 - HUDY EXCLUSIVE Limited Edition)

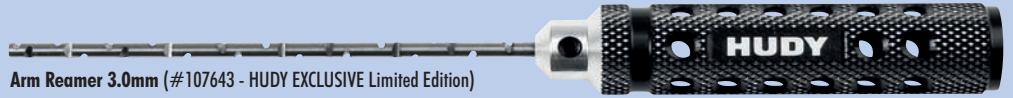

Arm Reamer 3.0mm (#107643 - HUDY EXCLUSIVE Limited Edition)



Socket 5.5mm (#175535 - HUDY EXCLUSIVE Limited Edition)



Socket 7.0mm (#177035 - HUDY EXCLUSIVE Limited Edition)



Reamer (#107602 - HUDY EXCLUSIVE Limited Edition)



Scissors (HUDY #188990)



Professional Multi Tool
(HUDY #183011)

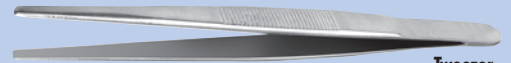

Tweezer

EQUIPMENT INCLUDED * Kit includes smaller but sufficient amount of oil and grease to build the car.

<p>700cSt (#106370) HUDY Premium Silicone Oils</p> <p>OIL CARPET</p>	<p>550cSt (#106355) HUDY Premium Silicone Oils</p> <p>OIL CARPET</p>	<p>10.000cSt (#106510) HUDY Premium Silicone Oils</p> <p>OIL CARPET</p>	<p>600cSt (#106360) HUDY Premium Silicone Oils</p> <p>OIL DIRT</p>	<p>500cSt (#106350) HUDY Premium Silicone Oils</p> <p>OIL DIRT</p>	<p>7.000cSt (#106470) HUDY Premium Silicone Oils</p> <p>OIL DIRT</p>	<p>100.000cSt (#106610) HUDY Premium Silicone Oils</p> <p>OIL DIRT</p>	<p>(HUDY #106210) Premium Graphite Grease</p> <p>GR CARPET DIRT</p>
---	---	--	---	---	---	---	--

EQUIPMENT REQUIRED

<p>Transmitter</p>	<p>Receiver</p>	<p>Speed Controller</p>	<p>Steering Servo</p>	<p>Electric Motor & Pinion Gear with Setscrew</p>	<p>LiPo Battery</p>	
<p>Battery Charger</p>	<p>Double-sided Tape (HUDY #107875)</p>	<p>Lexan™ Paint</p>	<p>4x Tires & Inserts</p>	<p>Bearing Oil (HUDY #106230)</p> <p>OIL</p>	<p>Threadlock</p> <p>TL</p>	<p>CA glue</p> <p>CA</p>

NOT INCLUDED



Follow Set-Up Book:
To ensure that you always have access to the most up-to-date version of the Set-up Book you can download the HUDY Set-up Book from their web site at [www.hudy.net] By offering this online version instead of including a hardcopy printed version in kits, you will always be assured of having the most current updated version.



SAMPLE OF OPTIONAL PARTS

OPTION	TYPE1	OPTION 1
#36XXXX	TYPE1	OPTION 1
#36XXXX	TYPE1	OPTION 2
#36XXXX	TYPE1	INCLUDED

XRAY offers wide range of optional tuning parts which are listed in a table like this. Please refer to the exploded view of each main section to verify which part is included in the kit while all other parts are available only as an optional part and must be purchased separately.

COLOR INDICATIONS

At the beginning of each section is an exploded view of the parts to be assembled. There is also a list of all the parts and part numbers that are related to the assembly of that section.

The part descriptions are color-coded to make it easier for you to identify the source of a part. Here are what the different colors mean:

- 364912 **STYLE A** - indicates parts that are included in the bag marked for the section.
- 361111 **STYLE B** - indicates parts that are included in the box.
- 364903 **STYLE C** - indicates parts that are already assembled from previous steps.

TECH TIPS

TIP DRIVE SHAFT PIN SERVICING

To enjoy the longest possible lifespan of the drive shafts and diff outdrives, it is extremely important to properly service the drive shaft pins. Inspect the pins after every 3 hours of runtime. If the pins show any wear, replace them with new pins.



Do not use drive shafts when the pins are worn.

Press out the worn pins.

Press in new pins and regularly inspect for wear.



For quick & easy drive pin replacements use #106000 HUDY Drive Pin Replacement Tool together with #106036 Ejector Pivot Pin & Alternating Pivot 2.5mm.



To replace the worn pins use only premium HUDY drive pins (#106053 2.5mm dia x 10mm length)

TIP GRAPHITE PARTS PREPARATION

Follow this Tech Tip to prepare the graphite parts. Sand the edges with sandpaper, and then seal the edges with CA glue to reinforce them and help prevent delamination.

Prepare all Graphite Parts:

- Front shock tower
- Rear shock tower

Fine sandpaper

Use fine sandpaper to sand smooth the edges of all graphite parts.

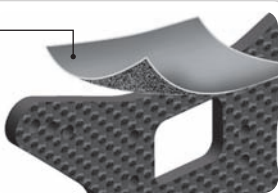

Apply CA glue to all edges of the graphite parts.

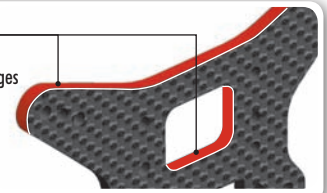

MANUAL STEPS ONLY FOR DIRT

1. BALL DIFFERENTIAL **DIRT**

MANUAL STEPS ONLY FOR CARPET

1. GEAR DIFFERENTIAL **CARPET**

MANUAL DUAL STEPS FOR CARPET AND DIRT

3. REAR DRIVETRAIN **CARPET** **DIRT**

1. FRONT & REAR DIFFERENTIAL

CARPET DIRT

#364941
OPTION
STEEL DIFFERENTIAL BEVEL GEAR
FOR LARGE VOLUME DIFF 41T

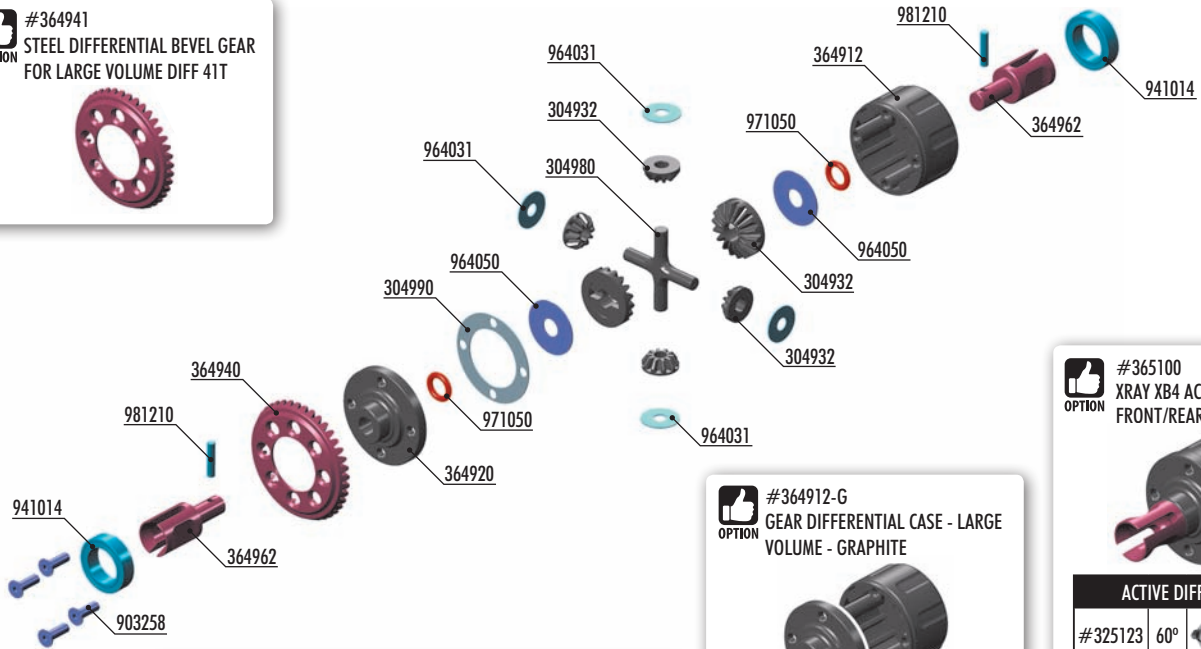

BEVEL & SATELLITE GEARS + PINS

#304932 + #304980	GRAPHITE	INCLUDED
#335030 + #335080	STEEL	OPTION

#364912-G
OPTION
GEAR DIFFERENTIAL CASE - LARGE
VOLUME - GRAPHITE



#364920-G
OPTION
GEAR DIFFERENTIAL COVER - LARGE
VOLUME - GRAPHITE

#365100
OPTION
XRAY XB4 ACTIVE DIFFERENTIAL
FRONT/REAR - SET



ACTIVE DIFF SEGMENTS

#325123	60°		OPTION
#325125	90°		INCLUDED
#325127	120°		OPTION

BAG



- 304932 GRAPHITE GEAR DIFF BEVEL & SATELLITE GEARS (2+4)
- 304980 COMPOSITE GEAR DIFF CROSS PIN
- 304990 DIFF GASKET (4)
- 364903 GEAR DIFFERENTIAL - LARGE VOLUME - SET
- 364912 COMPOSITE GEAR DIFFERENTIAL CASE - LARGE VOLUME
- 364920 COMPOSITE GEAR DIFFERENTIAL COVER - LARGE VOLUME
- 364940 STEEL DIFFERENTIAL BEVEL GEAR FOR LARGE VOLUME DIFF 40T

- 364962 GEAR DIFF OUTDRIVE ADAPTER FOR LARGE VOLUME DIFF (2)
- 903258 HEX SCREW SFH M2.5x8 (10)
- 941014 BALL-BEARING 10x15x4 RUBBER SEALED - GREASE (2)
- 964031 WASHER S 3.5x10x0.2 (10)
- 964050 WASHER S 5x15x0.3 (10)
- 971050 SILICONE O-RING 5x1.5 (10)
- 981210 PIN 2x10 (10)



964050
S 5x15x0.3



971050
O 5x1.5



981210
P 2x10

2x

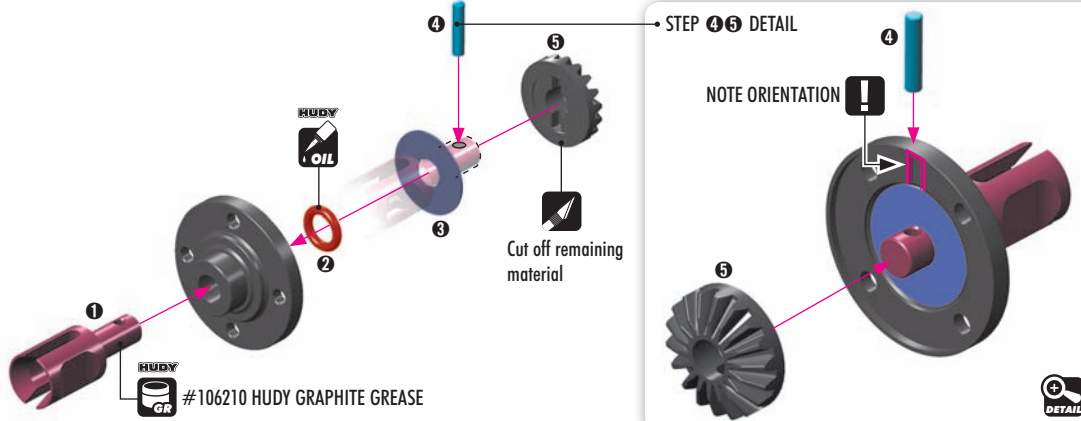

964050
S 5x15x0.3



971050
O 5x1.5



981210
P 2x10

2x

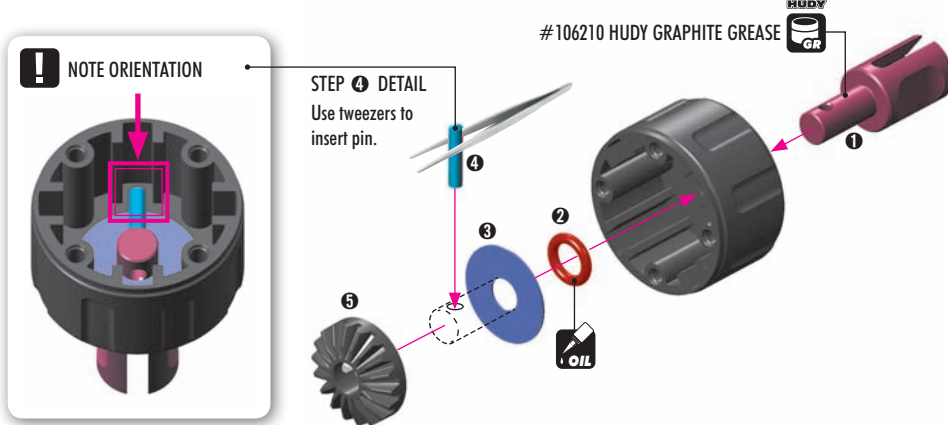



964031
S 3.5x10x0.2

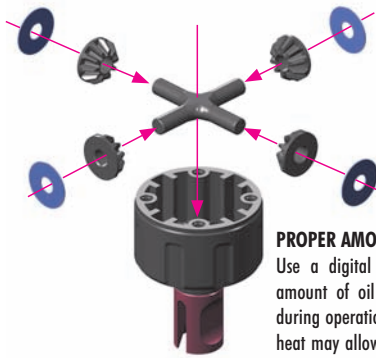

PROPER AMOUNT OF OIL IN THE DIFFS
Use a digital scale to measure the exact amount of oil in the diff. Remember that during operation the diff gets hotter and the heat may allow the oil to expand. If there is too much oil inside it may interfere with the diff operation and damage the internal gears.

Front diff Silicone oil
CARPET 10.000cSt
DIRT 7.000cSt
Fill just above the cross-pins.

Rear diff Silicone oil
10.000cSt CARPET
7.000cSt DIRT
Fill just above the cross-pins.

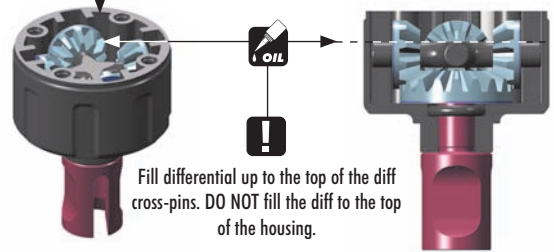

TO ENSURE YOU HAVE THE SAME AMOUNT OF OIL FROM REBUILD TO REBUILD, DO THE FOLLOWING:



① Put the diff (without oil) on the scale and check the weight (approximately 11.47g)

$$11.47g + 1.60g = 13.07g$$

② Slowly pour oil into the diff and watch the weight. Add 1.60g of oil into the diff. The approximate weight of the diff including oil is 13.07g.

TIPS FOR DIFFERENTIALS

TIP

FRONT DIFFERENTIAL

- LOW TRACTION 7.000cSt (HUDY #106470)
- MEDIUM-HIGH TRACTION 10.000cSt (HUDY #106510)
- SUPER-HIGH TRACTION 15.000cSt (HUDY #106515)

NOTE:
Softer oil increases steering, harder oil increases stability.

REAR DIFFERENTIAL

- LOW TRACTION 7.000cSt (HUDY #106470)
- MEDIUM-HIGH TRACTION 10.000cSt (HUDY #106510)
- SUPER-HIGH TRACTION 15.000cSt (HUDY #106515)

NOTE:
Softer oil increases rear traction, harder oil increases on-power steering.

SET-UP BOOK

DIFFERENTIAL OIL



903258
SFH M2.5x8



941014
BB 10x15x4

2x

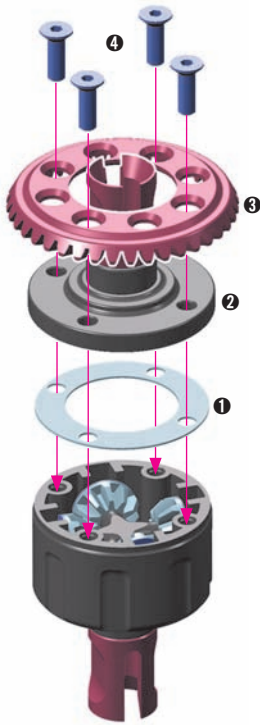

2x

Tighten the screws equally but do NOT tighten them completely.



2x

Use HUDY Ball-Bearing Grease

- HUDY #106220 - STANDARD
- HUDY #106221 - BLUE
- HUDY #106222 - RED

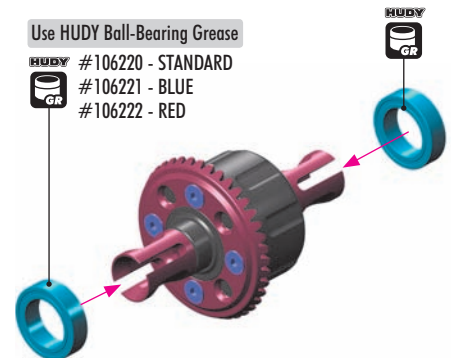

1. CENTER GEAR DIFFERENTIAL

DIRT

#365101 XRAY XB4 ACTIVE DIFFERENTIAL - CENTER - SET



ACTIVE DIFF SEGMENTS			
#325123	60°		OPTION
#325125	90°		INCLUDED
#325127	120°		OPTION

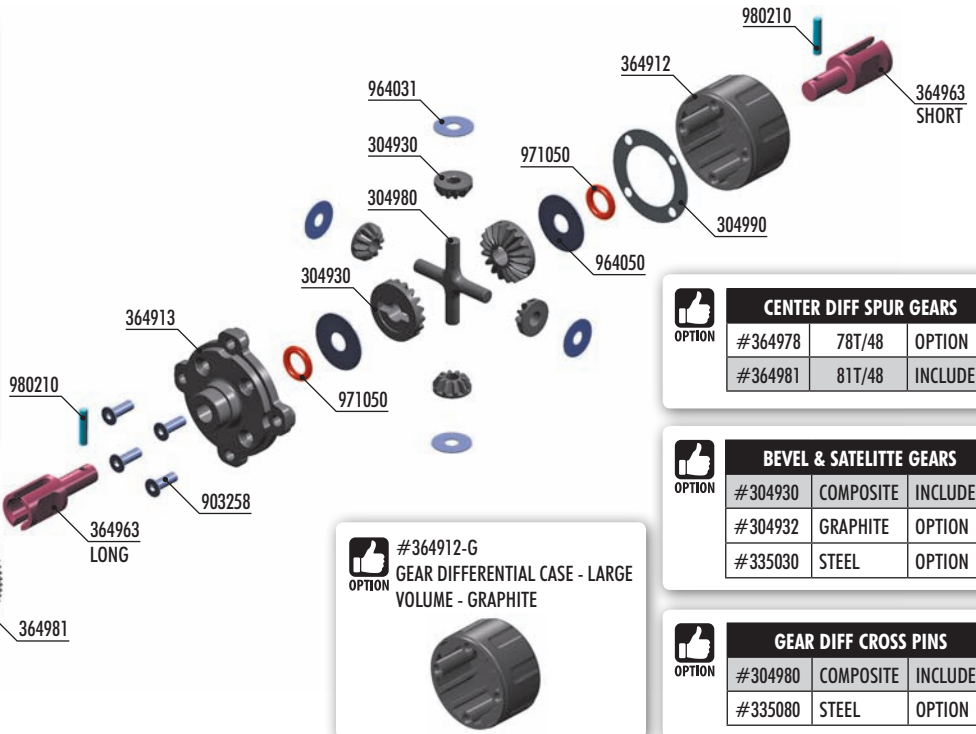

CENTER DIFF SPUR GEARS

#364978	78T/48	OPTION
#364981	81T/48	INCLUDED

BEVEL & SATELLITE GEARS

#304930	COMPOSITE	INCLUDED
#304932	GRAPHITE	OPTION
#335030	STEEL	OPTION

GEAR DIFF CROSS PINS

#304980	COMPOSITE	INCLUDED
#335080	STEEL	OPTION

#364912-G
 GEAR DIFFERENTIAL CASE - LARGE VOLUME - GRAPHITE

BAG

- 304930 COMPOSITE GEAR DIFF BEVEL & SATELLITE GEARS (2+4)
- 304980 COMPOSITE GEAR DIFF CROSS PIN
- 304990 DIFF GASKET (4)
- 364904 GEAR CENTER DIFFERENTIAL - LARGE VOLUME - SET
- 364912 COMPOSITE GEAR DIFFERENTIAL CASE - LARGE VOLUME
- 364913 COMPOSITE CENTER GEAR DIFF ADAPTER - LARGE VOLUME
- 364963 CENTER GEAR DIFF OUTDRIVE ADAPTER FOR LARGE VOLUME DIFF (1+1)
- 364981 COMPOSITE CENTER DIFF SPUR GEAR 81T / 48

- 902306 HEX SCREW SH M3x6 (10)
- 903258 HEX SCREW SFH M2.5x8 (10)
- 964031 WASHER S 3.5x10x0.2 (10)
- 964050 WASHER S 5x15x0.3 (10)
- 971050 SILICONE O-RING 5x1.5 (10)
- 980210 PIN 2x10 (10)

- 964050
WASHER S 5x15x0.3
- 971050
O-RING 5x1.5
- 980210
PIN 2x10

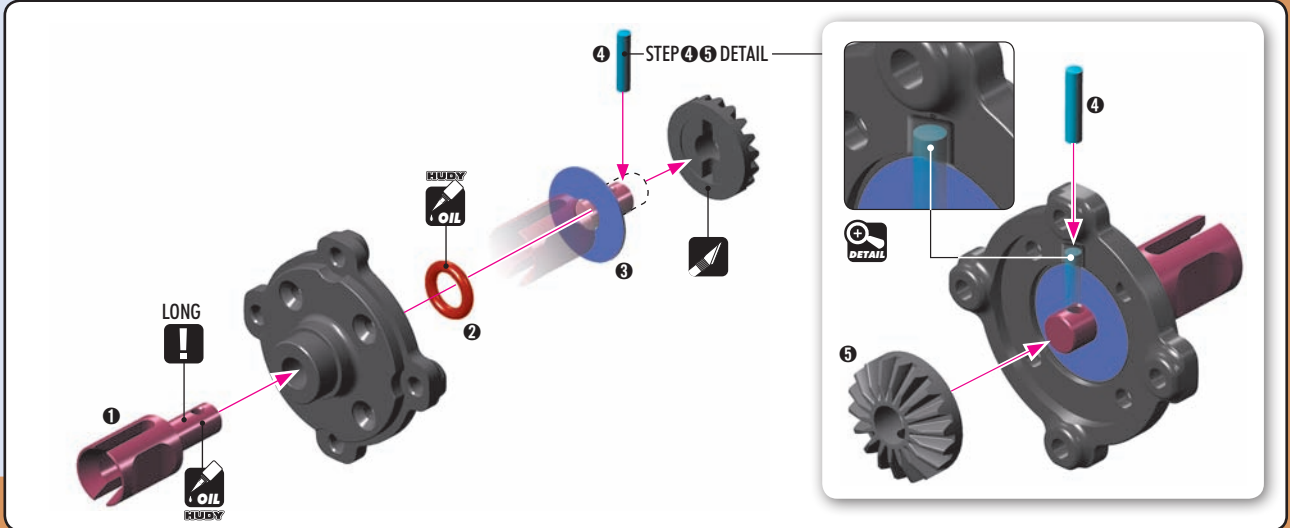

- 964050
WASHER S 5x15x0.3
- 971050
O-RING 5x1.5
- 980210
PIN 2x10

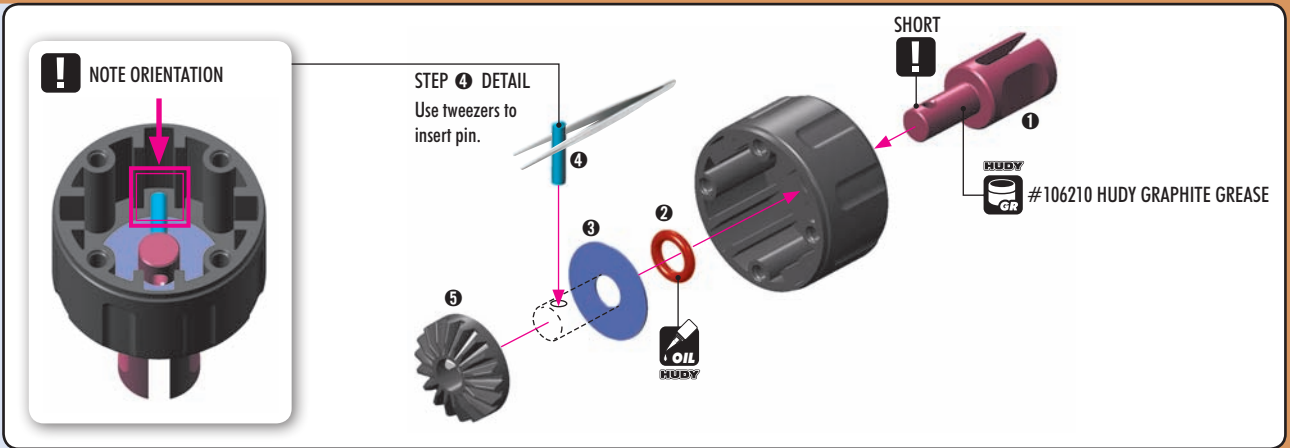



964031
S 3.5x10x0.2

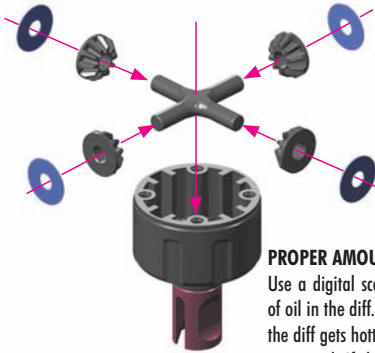

PROPER AMOUNT OF OIL IN THE DIFFS

Use a digital scale to measure the exact amount of oil in the diff. Remember that during operation the diff gets hotter and the heat may allow the oil to expand. If there is too much oil inside it may interfere with the diff operation and damage the internal gears.



Center diff

Silicone oil 100.000cSt
Fill just above the cross-pins.

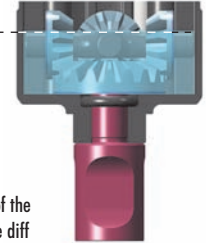

Fill differential up to the top of the diff cross-pins. DO NOT fill the diff to the top of the housing.

TO ENSURE YOU HAVE THE SAME AMOUNT OF OIL FROM REBUILD TO REBUILD, DO THE FOLLOWING:



1 Put the diff (without oil) on the scale and check the weight (approximately 11.72g)

#107865
HUDY Ultimate Digital Pocket
Scale 300g ± 0.01g



2 Slowly pour oil into the diff and watch the weight.

CENTER Diff. 11.72g + 1.50g = 13.22g

TIP FOR CENTER DIFFERENTIAL

LOW TRACTION	50.000cSt (HUDY #106550)
MEDIUM TRACTION	100.000cSt (HUDY #106610)
HIGH TRACTION	500.000cSt (HUDY #106650)

NOTE:
Softer oil increases steering, harder oil increases stability.

SET-UP BOOK

DIFFERENTIAL OIL

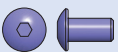

902306
SH M3x6



903258
SFH M2.5x8

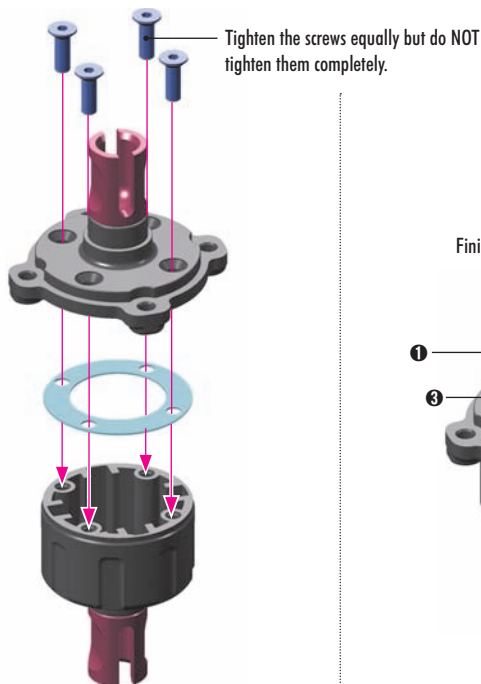

Finish tightening in this order.

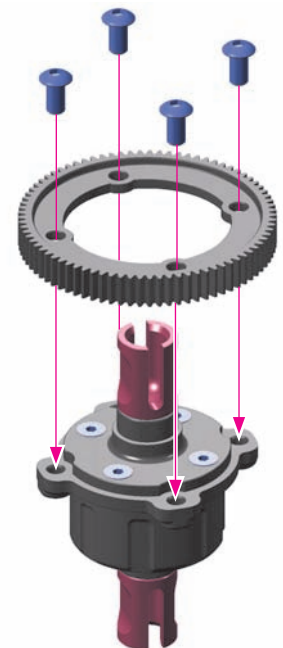
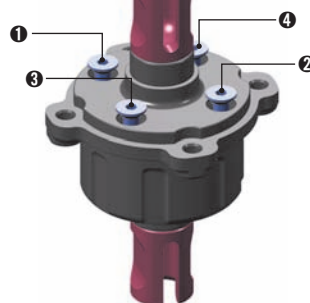

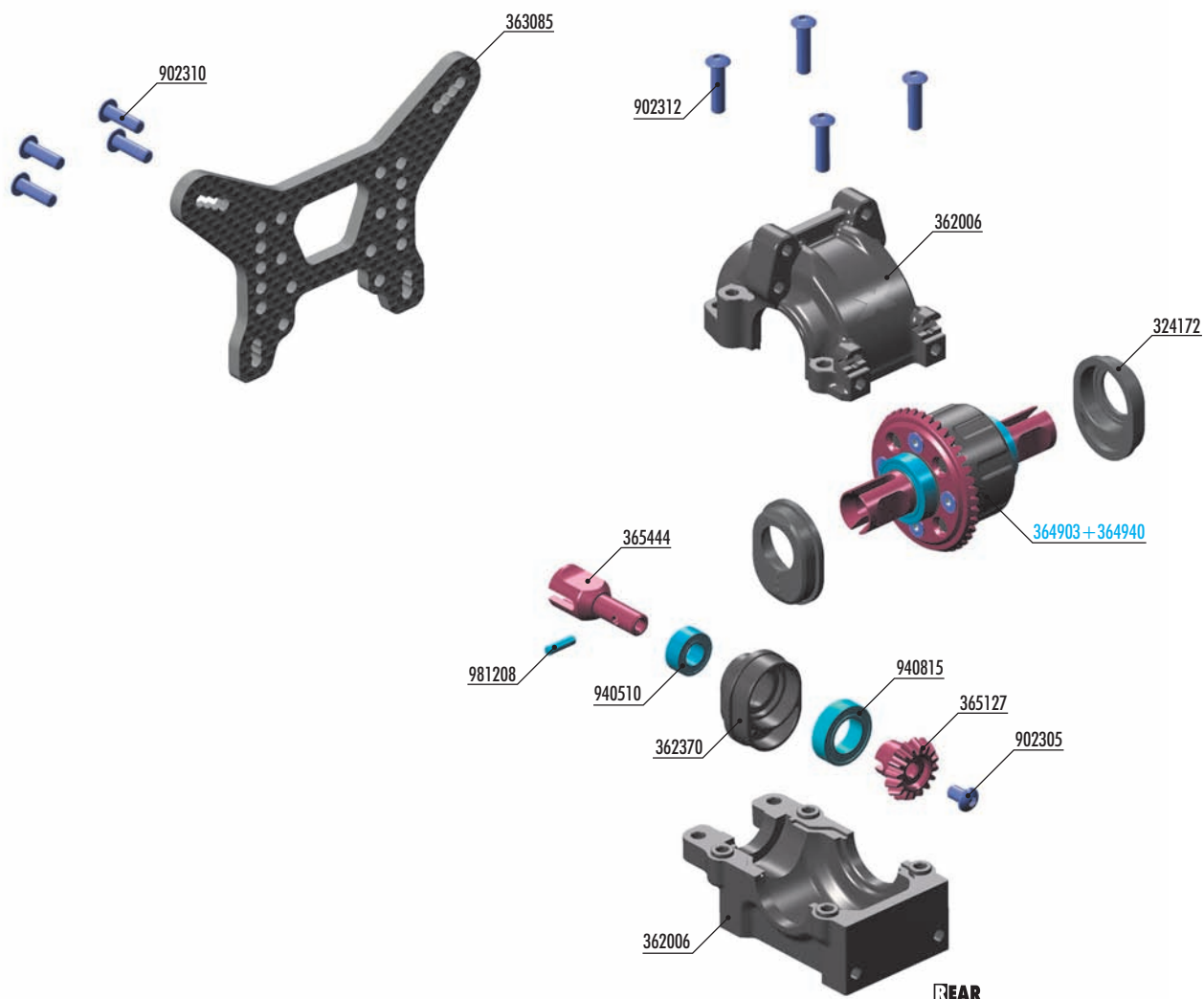

REAR

XRAY BALL-BEARING				
OPTION	#359050	5x10x4	GREASE	OPTION
	#940510	5x10x4	OIL	INCLUDED
	#940814	8x14x4	GREASE	OPTION
	#940815	8x14x4	OIL	INCLUDED

BALL-BEARING HUB			
OPTION	#324172	1 DOT	OPTION
	#324172	2 DOTS	OPTION
	#324172	3 DOTS	INCLUDED

INLINE HUB - REAR			
OPTION	#362370	1 DOT	OPTION
	#362370	2 DOTS	OPTION
	#362370	3 DOTS	INCLUDED

ACTIVE DIFF SEGMENTS			
OPTION	#325123	60°	OPTION
	#325125	90°	INCLUDED
	#325127	120°	OPTION



- 324172 COMPOSITE ADJUSTMENT BALL-BEARING HUB (2)
- 362006 DIFF BULKHEAD - HORIZONTAL SPLIT DESIGN (HS) - FRONT/REAR - SET
- 362370 INLINE HUB FOR BEVEL DRIVE GEAR - REAR HS BULKHEAD - 1+2+3 DOTS
- 363085 GRAPHITE SHOCK TOWER FOR HS BULKHEAD - REAR - 3.5MM
- 365127 STEEL BEVEL DRIVE GEAR - FOR HS BULKHEAD - CNC-MACHINED - 16T
- 365444 CENTRAL DOGBONE SHAFT UNIVERSAL JOINT - HUDY SPRING STEEL™

- 902305 HEX SCREW SH M3x5 (10)
- 902310 HEX SCREW SH M3x10 (10)
- 902312 HEX SCREW SH M3x12 (10)
- 940510 BALL-BEARING 5x10x4 RUBBER SEALED - OIL (2)
- 940815 BALL-BEARING 8x14x4 RUBBER SEALED - OIL (2)
- 981208 PIN 2x8 (10)
- 364903 GEAR DIFFERENTIAL - LARGE VOLUME - SET
- 364940 STEEL DIFFERENTIAL BEVEL GEAR FOR LARGE VOLUME DIFF 40T



902305
SH M3x5

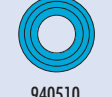

940510
BB 5x10x4



940815
BB 8x14x4

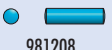

981208
P 2x8



902312
SH M3x12



902312
SH M3x12



902310
SH M3x10

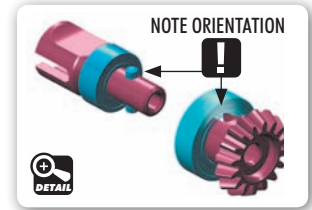
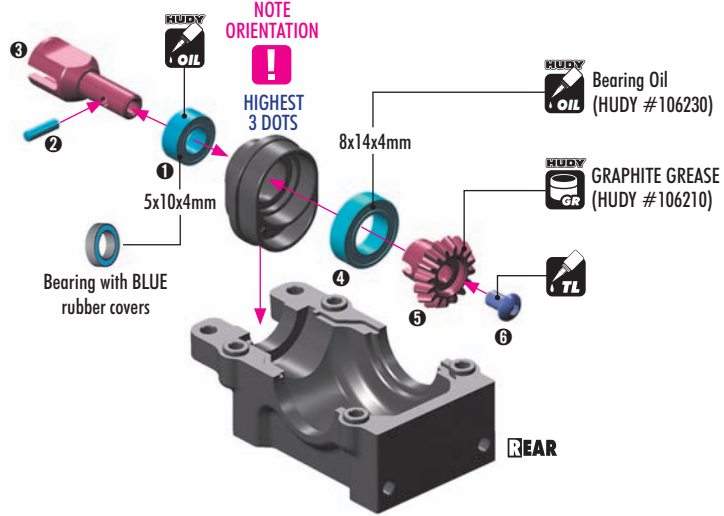

CARPET

BEVEL DRIVE GEAR & DIFFERENTIAL HEIGHT ADJUSTMENT

INITIAL SETTING

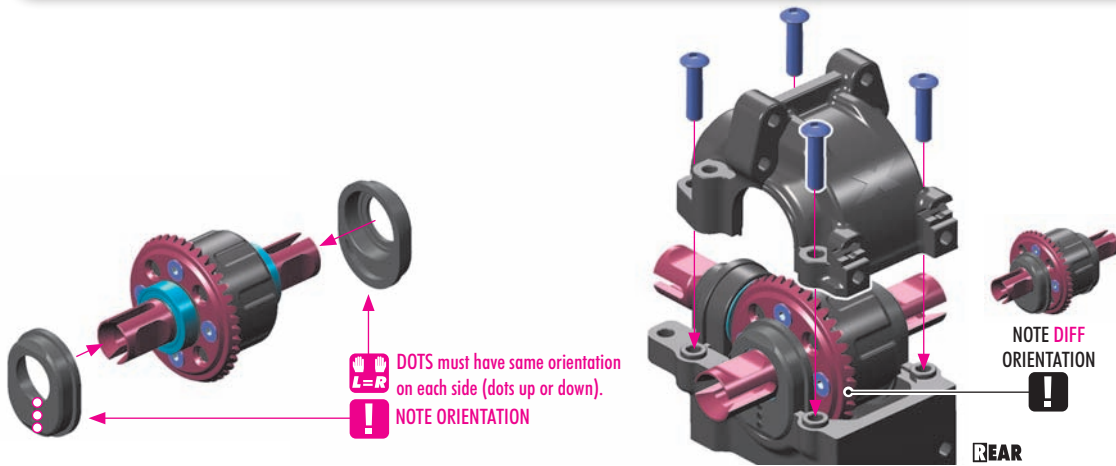
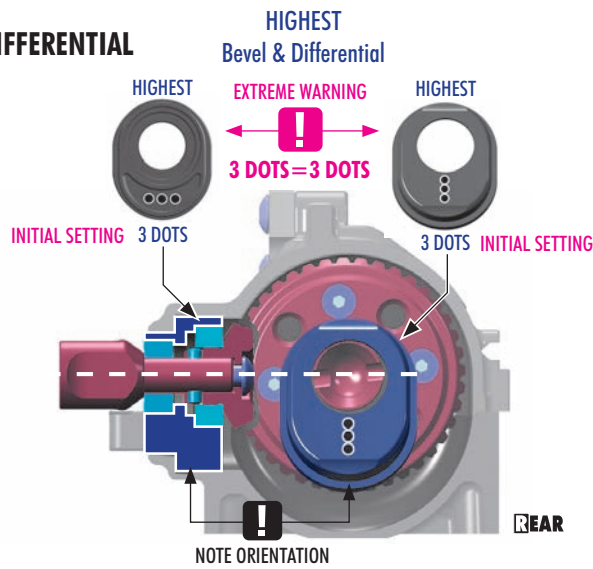

TIP Follow the TECH TIP on page 5 to prepare graphite parts.



902305
SH M3x5



940510
BB 5x10x4



940815
BB 8x14x4



981208
P 2x8

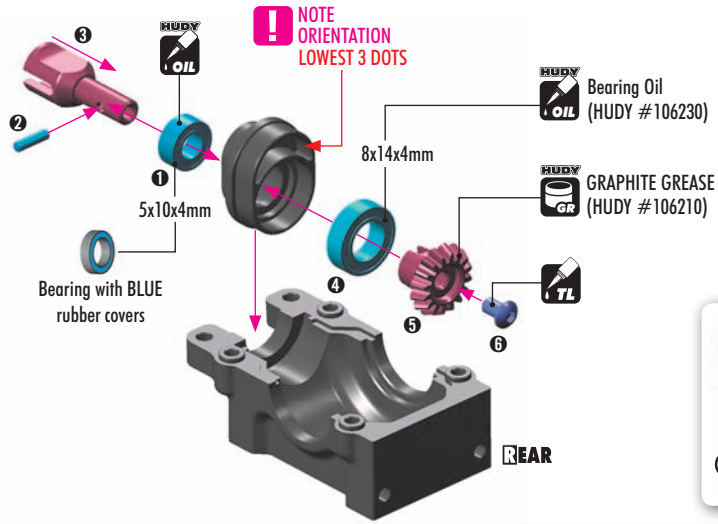

DIRT REAR BEVEL DRIVE GEAR & DIFFERENTIAL HEIGHT ADJUSTMENT

INITIAL SETTING

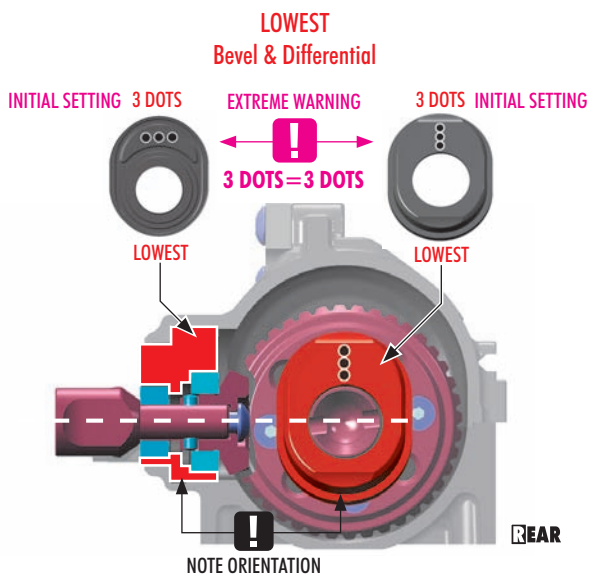

902312
SH M3x12

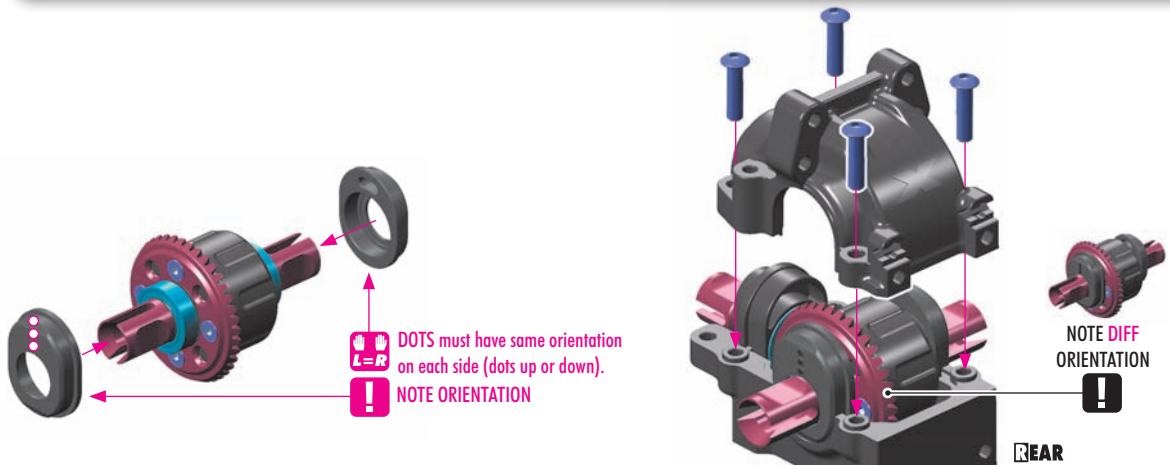

902310
SH M3x10

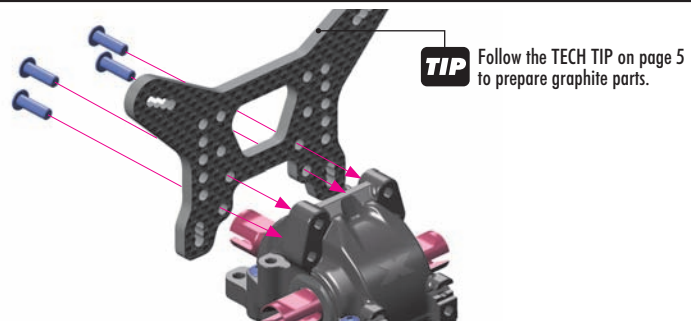

#365100
OPTION XRAY XB4 ACTIVE DIFFERENTIAL FRONT/REAR - SET



ACTIVE DIFF SEGMENTS

#325123	60°		OPTION
#325125	90°		INCLUDED
#325127	120°		OPTION

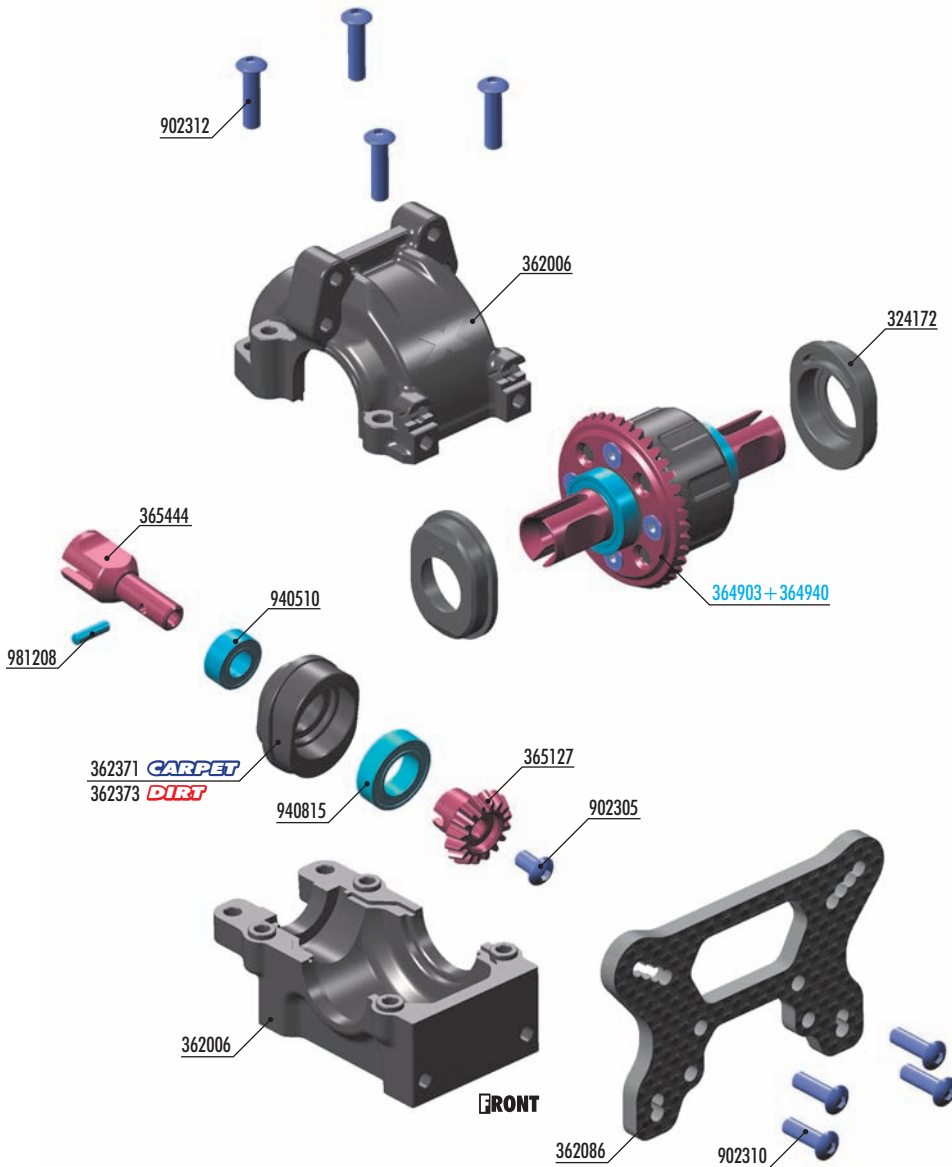

OPTION	BALL-BEARING HUB	
#324172	1 DOT	INCLUDED
#324172	2 DOTS	OPTION
#324172	3 DOTS	INCLUDED
OPTION	ANGLE HUB - FRONT	
#362371	1 DOT	INCLUDED
#362372	2 DOTS	OPTION
#362373	3 DOTS	INCLUDED

OPTION	XRAY BALL-BEARING	
#359050	5x10x4	GREASE OPTION
#940510	5x10x4	OIL INCLUDED
#940814	8x14x4	GREASE OPTION
#940815	8x14x4	OIL INCLUDED

BAG



- 324172 COMPOSITE ADJUSTMENT BALL-BEARING HUB (2)
- 362006 DIFF BULKHEAD BLOCK SET
- 362086 GRAPHITE SHOCK TOWER FOR HS BULKHEAD - FRONT - 3.5MM
- 362371 ANGLED HUB FOR BEVEL DRIVE GEAR - FRONT HS BULKHEAD - 1 DOT
- 362373 ANGLED HUB FOR BEVEL DRIVE GEAR - FRONT HS BULKHEAD - 3 DOTS
- 365127 STEEL BEVEL DRIVE GEAR - FOR HS BULKHEAD - CNC-MACHINED - 16T
- 365444 CENTRAL DOGBONE SHAFT UNIVERSAL JOINT - HUDY SPRING STEEL™

- 902305 HEX SCREW SH M3x5 (10)
- 902310 HEX SCREW SH M3x10 (10)
- 902312 HEX SCREW SH M3x12 (10)
- 940510 BALL-BEARING 5x10x4 RUBBER SEALED - OIL (2)
- 940815 BALL-BEARING 8x14x4 RUBBER SEALED - OIL (2)
- 981208 PIN 2x8 (10)

- 364903 GEAR DIFFERENTIAL - LARGE VOLUME - SET
- 364940 STEEL DIFFERENTIAL BEVEL GEAR FOR LARGE VOLUME DIFF 40T

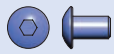

902305
SH M3x5



940510
BB 5x10x4



940815
BB 8x14x4



981208
P 2x8



902312
SH M3x12



902310
SH M3x10

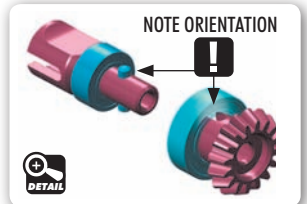
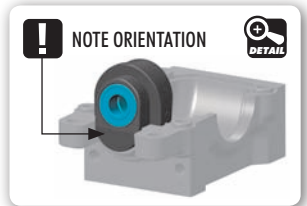
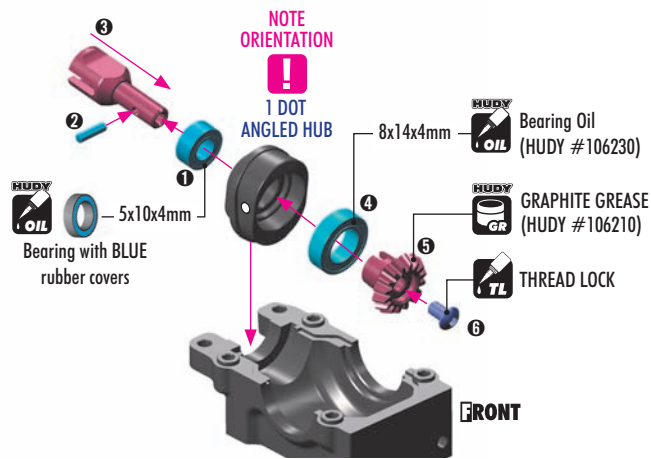

CARPET

REAR BEVEL DRIVE GEAR & DIFFERENTIAL HEIGHT ADJUSTMENT



INITIAL SETTING
BEVEL GEAR ADJ.

INITIAL SETTING
DIFF HEIGHT ADJ.

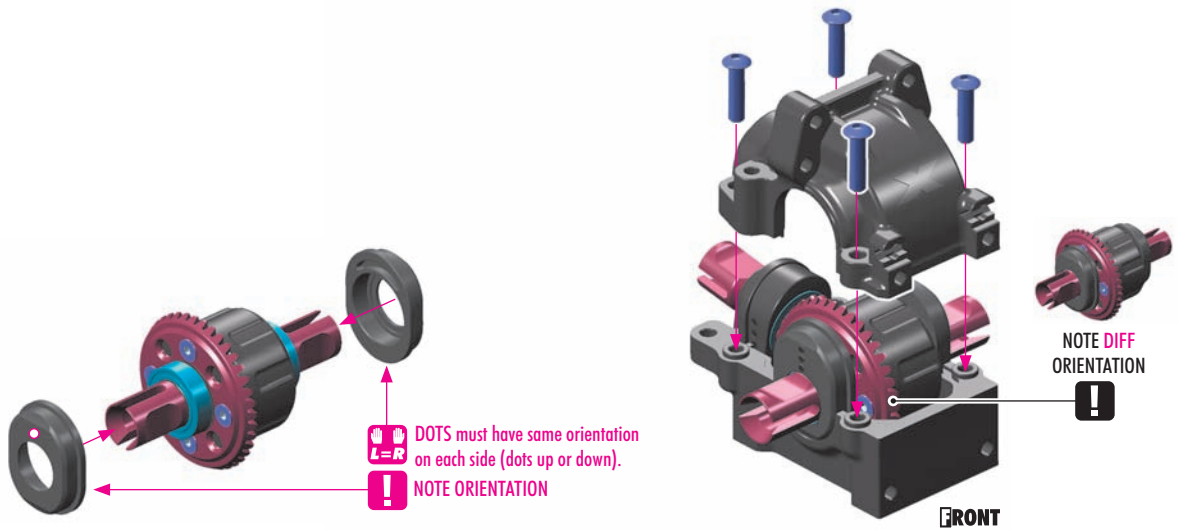
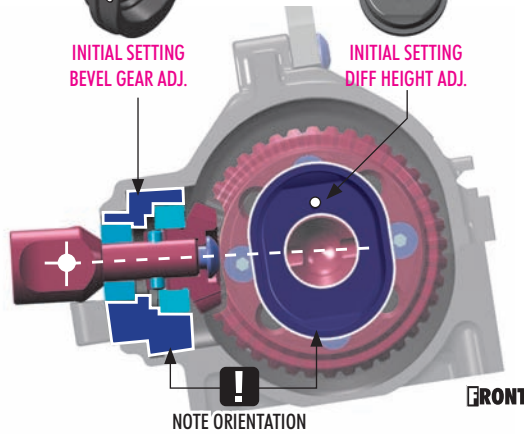

TIP Follow the TECH TIP on page 5 to prepare graphite parts.

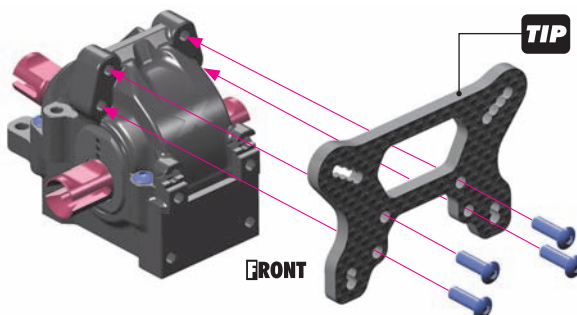

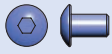

902305
SH M3x5



940510
BB 5x10x4



940815
BB 8x14x4



981208
P 2x8



902312
SH M3x12

902310
SH M3x10

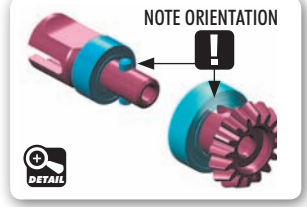
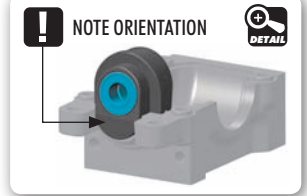
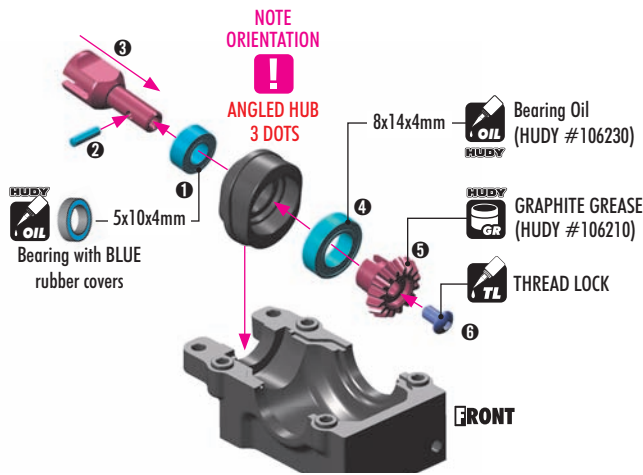

REAR BEVEL DRIVE GEAR & DIFFERENTIAL HEIGHT ADJUSTMENT

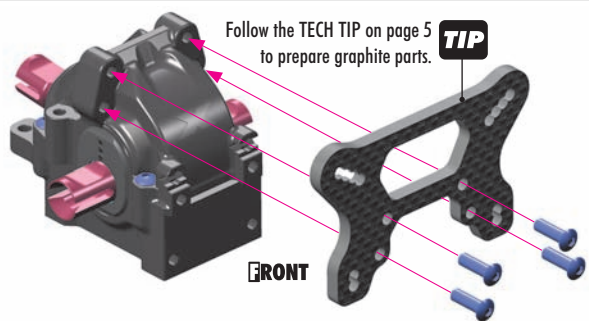
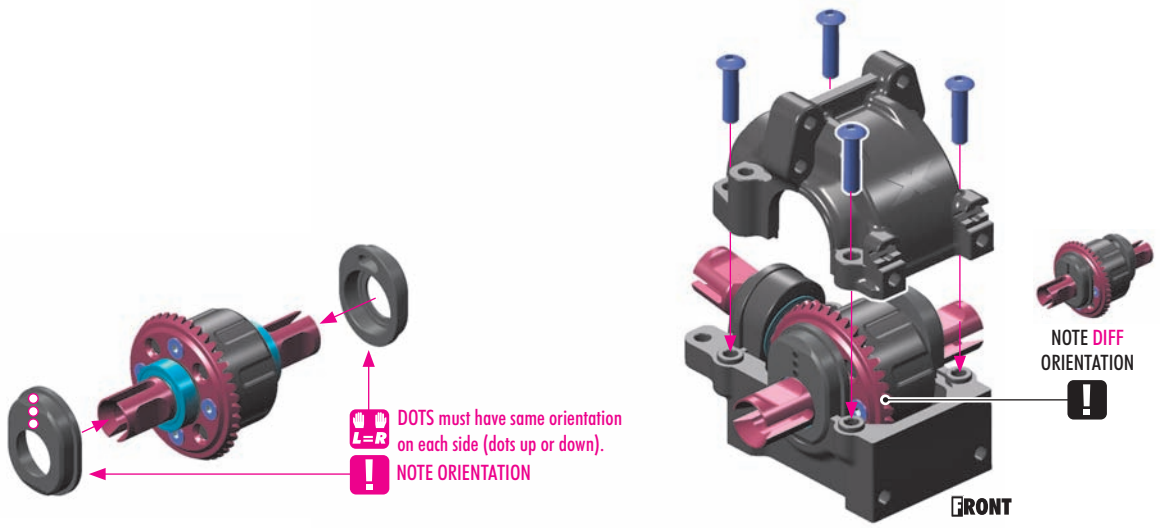
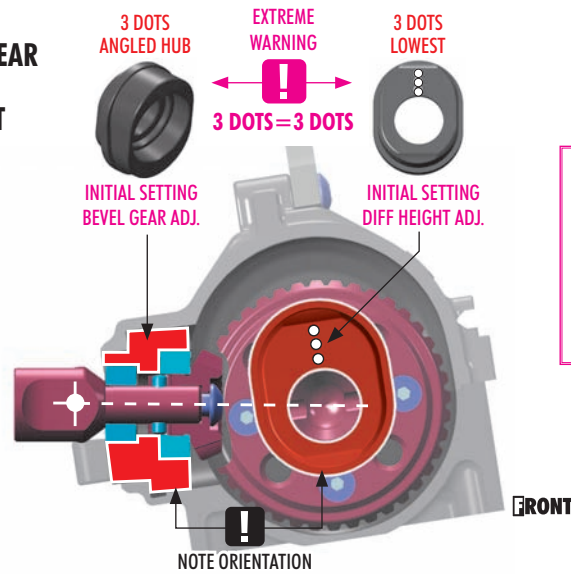

3. REAR SUSPENSION

CARPET DIRT

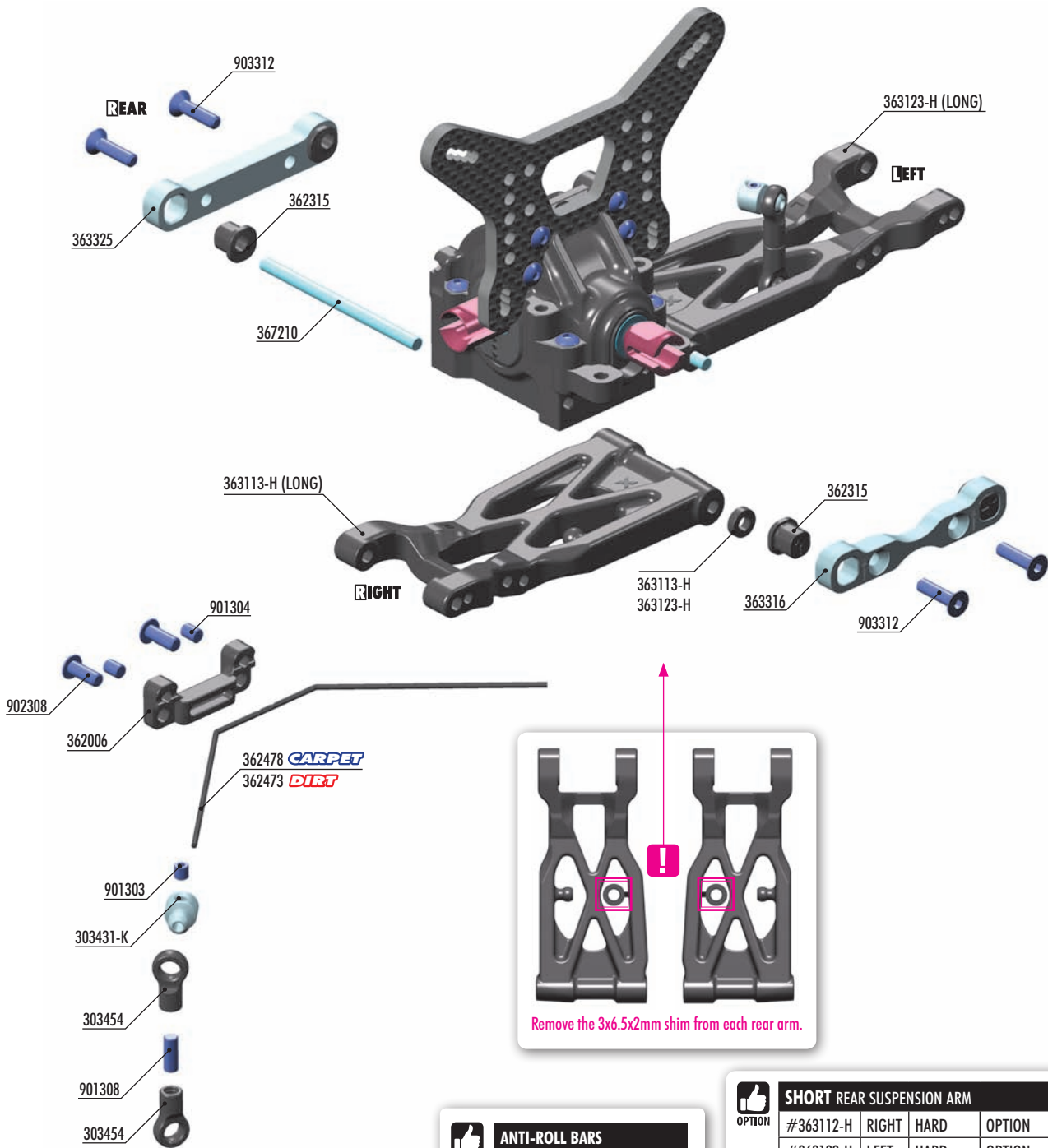

OPTION	ANTI-ROLL BARS
OPTION	#362470 1.0mm OPTION
	#362471 1.1mm OPTION
	#362472 1.2mm OPTION
	#362473 1.3mm INCLUDED
	#362474 1.4mm OPTION
	#362476 1.6mm OPTION
	#362478 1.8mm INCLUDED
	#362480 2.0mm OPTION

OPTION	SHORT REAR SUSPENSION ARM
OPTION	#363112-H RIGHT HARD OPTION
	#363122-H LEFT HARD OPTION
	#363112-G RIGHT GRAPHITE OPTION
	#363122-G LEFT GRAPHITE OPTION

OPTION	LONG REAR SUSPENSION ARM
OPTION	#363113-H RIGHT HARD INCLUDED
	#363123-H LEFT HARD INCLUDED
	#363113-G RIGHT GRAPHITE OPTION
	#363123-G LEFT GRAPHITE OPTION

BAG

03

- 303431-K ALU 4.9MM BALL END - BLACK (2)
- 303454 BALL JOINT 4.9MM - OPEN (4)
- 362006 DIFF BULKHEAD BLOCK SET
- 362315 ECCENTRIC BUSHING SET (2)
- 362473 ANTI-ROLL BAR 1.3 MM
- 362478 ANTI-ROLL BAR 1.8 MM
- 363113-H COMPOSITE LONG SUSPENSION ARM REAR LOWER RIGHT - HARD
- 363123-H COMPOSITE LONG SUSPENSION ARM REAR LOWER LEFT - HARD
- 363316 ALU SUSPENSION HOLDER FOR HS BULKHEAD - REAR-FRONT
- 363325 ALU SUSPENSION HOLDER 2° FOR HS BULKHEAD - REAR-REAR

- 367210 SUSPENSION PIVOT PIN (2)
- 901303 HEX SCREW SB M3x3 (10)
- 901304 HEX SCREW SB M3x4 (10)
- 901308 HEX SCREW SB M3x8 (10)
- 902308 HEX SCREW SH M3x8 (10)
- 903312 HEX SCREW SFH M3x12 (10)

10

From Rear Arm SHIM 3x6.5x2



903312 SFH M3x12

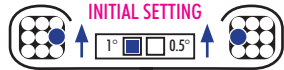
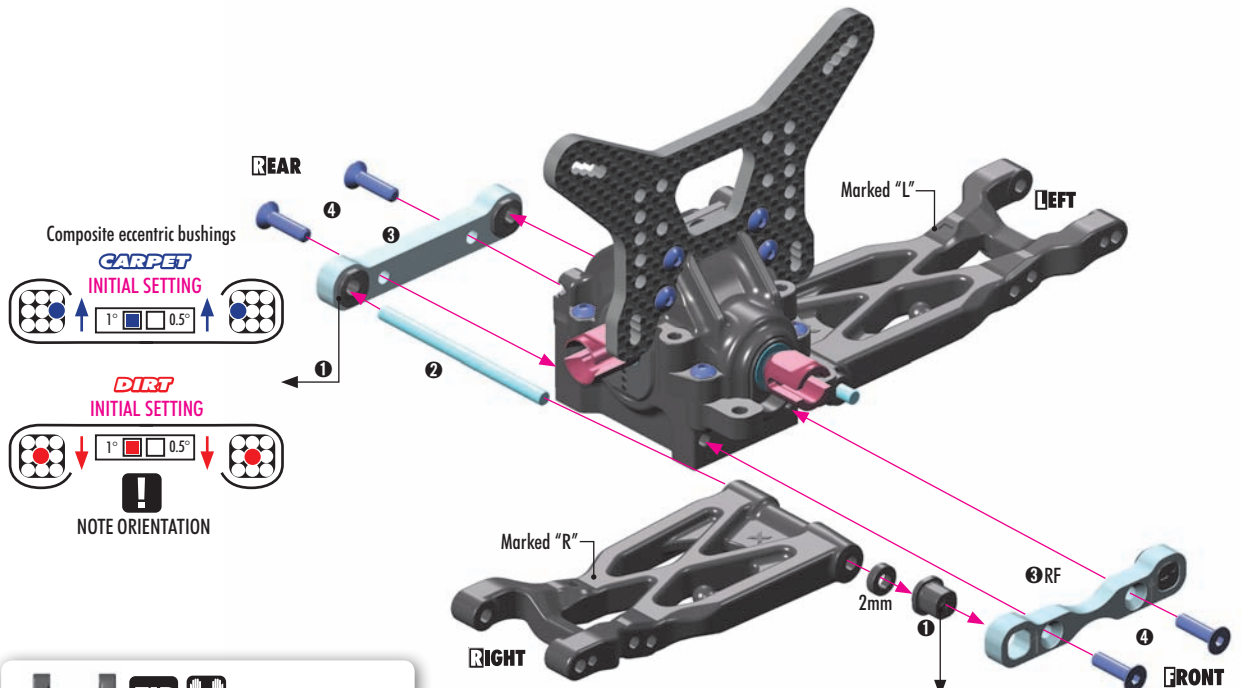

NOTE ORIENTATION

TIP If the suspension arm does not move freely use a HUDY Arm Reamer to size the holes of the arms.
Arm Reamer 3.0mm (HUDY #107633)



NOTE ORIENTATION

SHORT REAR SUSPENSION ARM

OPTION	Part #	Side	Material	Availability
	#363112-H	RIGHT	HARD	OPTION
	#363122-H	LEFT	HARD	OPTION
	#363112-G	RIGHT	GRAPHITE	OPTION
	#363122-G	LEFT	GRAPHITE	OPTION

LONG REAR SUSPENSION ARM

OPTION	Part #	Side	Material	Availability
	#363113-H	RIGHT	HARD	INCLUDED
	#363123-H	LEFT	HARD	INCLUDED
	#363113-G	RIGHT	GRAPHITE	OPTION
	#363123-G	LEFT	GRAPHITE	OPTION

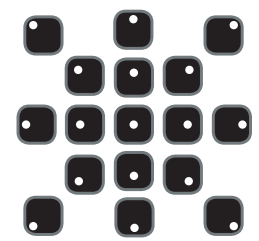

ECCENTRIC BUSHINGS HAVE TWO DIFFERENT OFFSETS FROM THE CENTER.

Middle position = 0.5° or 0.375mm from center. Outer position = 1° or 0.75mm from center.

The XRAY rear alu lower suspension holders provide great range of adjustment for the rear suspension. Using different combinations of eccentric bushings, fine adjustment of rear anti-squat, rear toe-in, rear roll center, and rear track-width can be obtained. For more information about the influence of rear anti-squat, rear toe-in, rear roll center and rear track width on car handling, please refer to HUDY Set-up Book (#209100).

ANTI-SQUAT		
RR	RF	(°)
		=2°
		=3°
		=1°
		=3°
		=2°
		=4°
		=1°
		=2°
		=0°

ROLL CENTER		
RR	RF	(mm)
		=+0.75mm
		=0mm
		=-0.75mm

TRACK-WIDTH		
RR	RF	(mm)
		=+1.5mm
		=0mm
		=-1.5mm

TOE-IN		
RR	RF	(°)
		=2°
		=3°
		=1°
		=3°
		=2°
		=0°
		=3°
		=4°
		=2°

The track-width is directly influenced by the size of the wheels and tires used.

The tables describe the amounts of adjustment using the center and outside positions of the eccentric bushings. The middle position eccentric bushings allow for finer adjustment increments.

901308
SB M3x8

2x
L=R

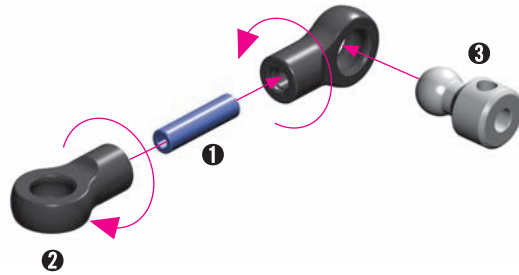
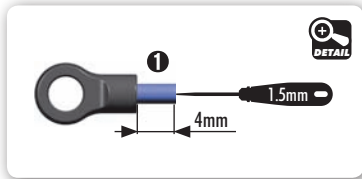

901303
SB M3x3

901304
SB M3x4

902308
SH M3x8

STEP 3 DETAIL

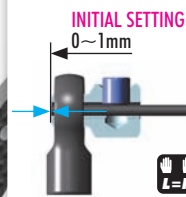

OPTION	ANTI-ROLL BARS		
#362470	1.0mm	OPTION	
#362471	1.1mm	OPTION	
#362472	1.2mm	OPTION	
#362473	1.3mm	INCLUDED	
#362474	1.4mm	OPTION	
#362476	1.6mm	OPTION	
#362478	1.8mm	INCLUDED	
#362480	2.0mm	OPTION	

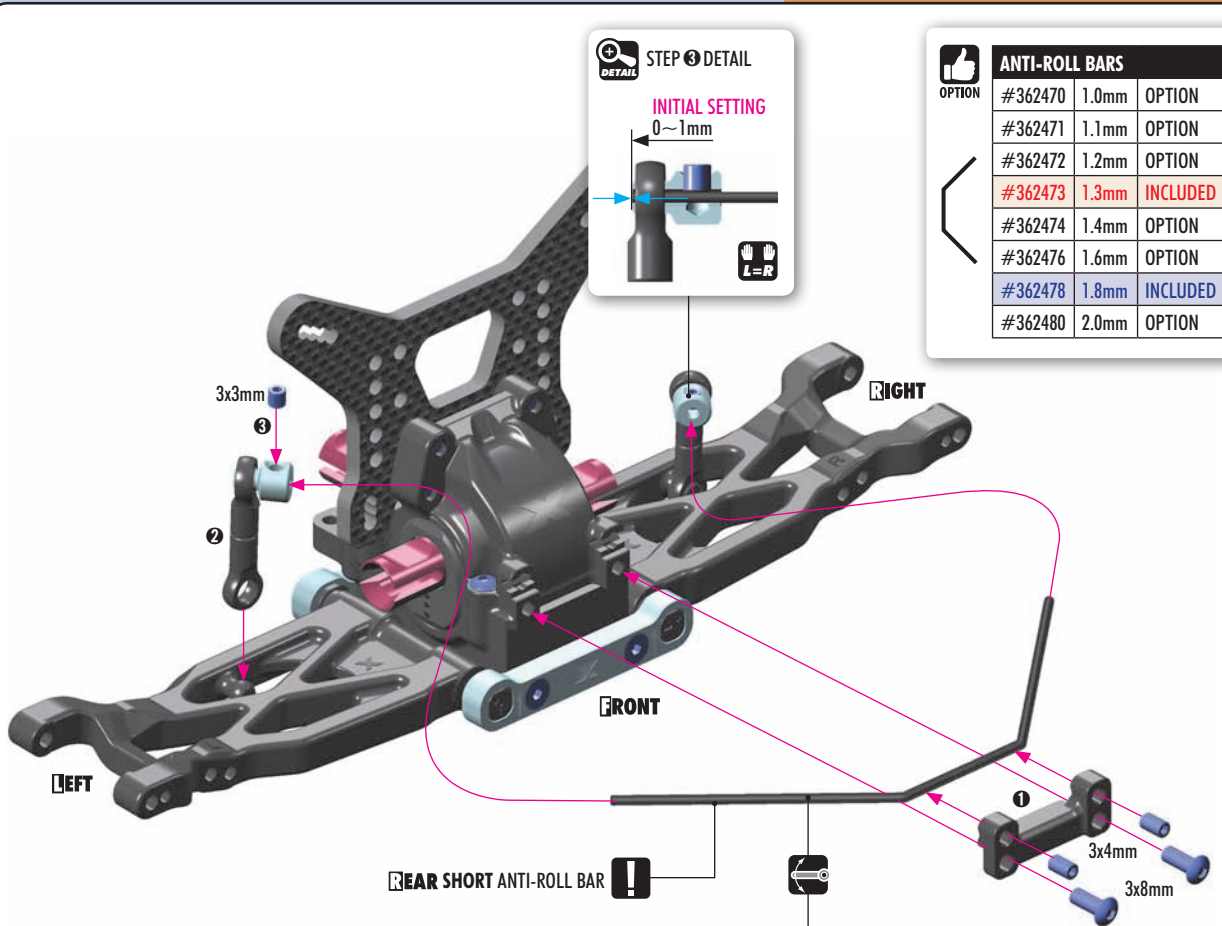

! In case the anti-roll bar wire is long and will touch the shock absorber then you have to cut approximately 3mm from each end of the wire.

CUT approx. 3mm

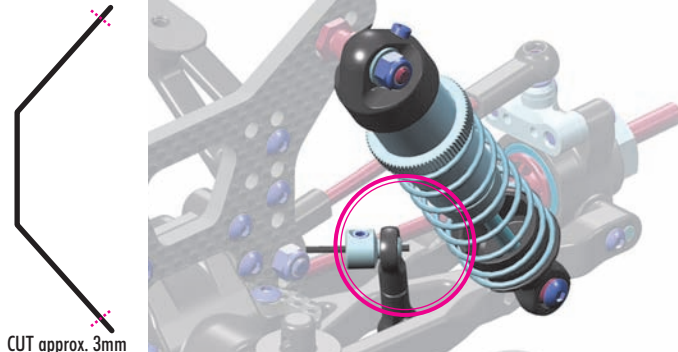

CUT approx. 3mm

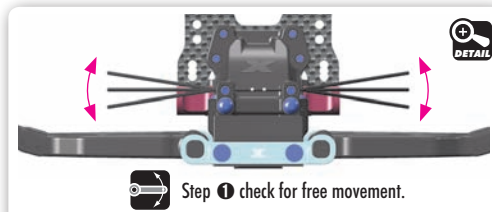
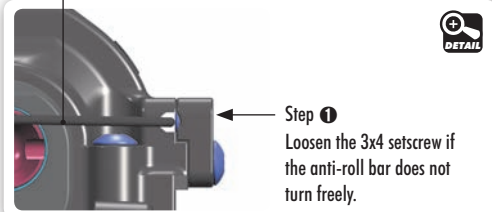

SET-UP BOOK

ANTI-ROLL BAR

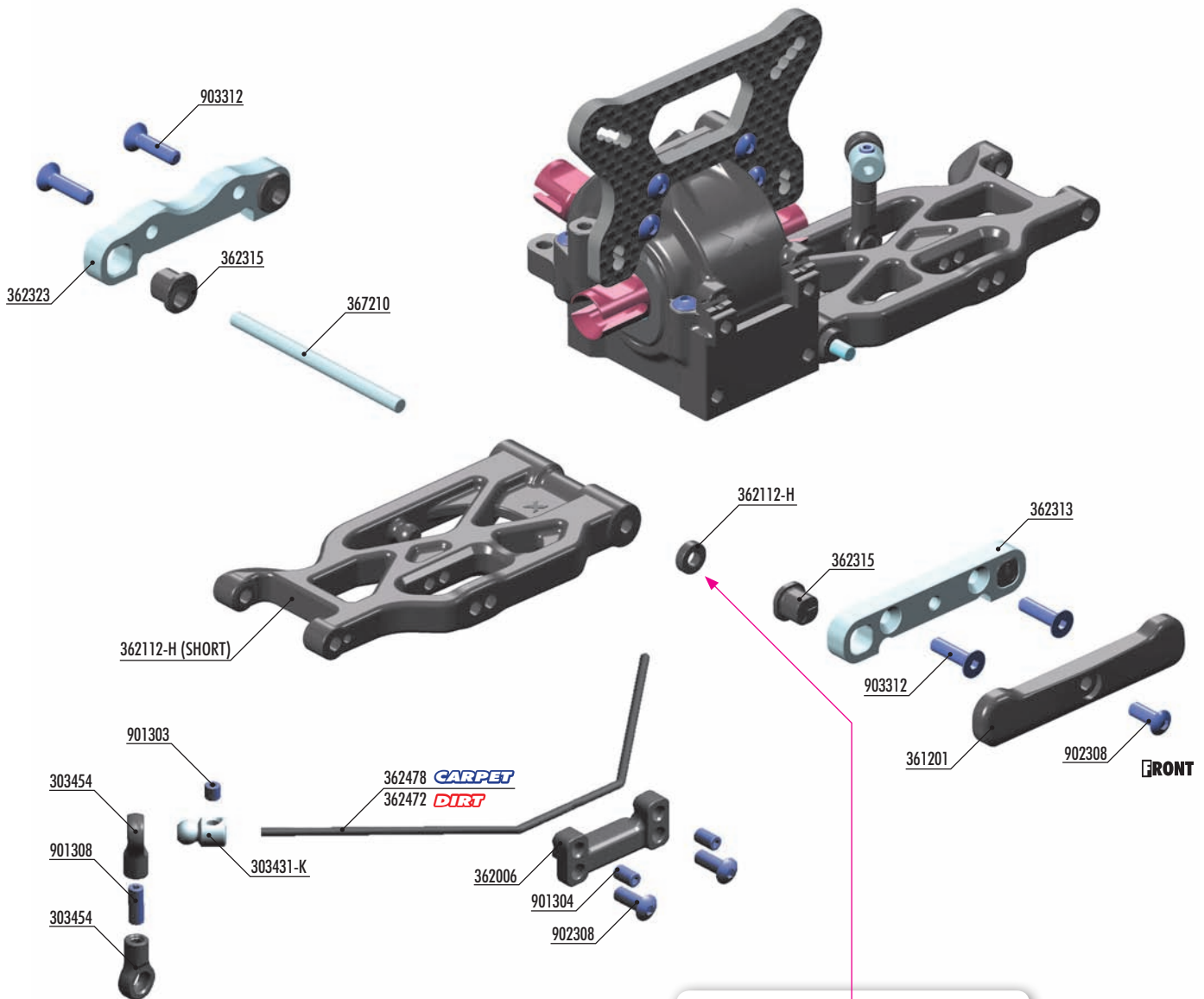

ANTI-ROLL BARS			
OPTION	#362470	1.0mm	OPTION
	#362471	1.1mm	OPTION
	#362472	1.2mm	INCLUDED
	#362473	1.3mm	OPTION
	#362474	1.4mm	OPTION
	#362476	1.6mm	OPTION
	#362478	1.8mm	INCLUDED
	#362480	2.0mm	OPTION

SHORT FRONT SUSPENSION ARM			
OPTION	#362112	MEDIUM	OPTION
	#362112-H	HARD	INCLUDED
	#362112-G	GRAPHITE	OPTION

LONG FRONT SUSPENSION ARM			
OPTION	#362113-H	HARD	OPTION
	#362113-G	GRAPHITE	OPTION



BAG



- 303431-K ALU 4.9MM BALL END - BLACK (2)
- 303454 BALL JOINT 4.9MM - OPEN (4)
- 361201 COMPOSITE FRONT BUMPER - ONE HOLE
- 362006 DIFF BULKHEAD - HORIZONTAL SPLIT DESIGN (HS) - FRONT/REAR - SET
- 362112-H COMPOSITE SUSPENSION ARM FRONT LOWER - HARD
- 362313 ALU LOWER SUSP. HOLDER FOR HS BULKHEAD - FRONT-FRONT
- 362315 ECCENTRIC BUSHING SET (2)
- 362323 ALU LOWER SUSP. HOLDER FOR HS BULKHEAD - FRONT-REAR
- 362472 ANTI-ROLL BAR 1.2 MM
- 362478 ANTI-ROLL BAR 1.8 MM
- 367210 SUSPENSION PIVOT PIN (2)

- 901303 HEX SCREW SB M3x3 (10)
- 901304 HEX SCREW SB M3x4 (10)
- 901308 HEX SCREW SB M3x8 (10)
- 902308 HEX SCREW SH M3x8 (10)
- 903312 HEX SCREW SFH M3x12 (10)

10

From Front Arm
SHIM 3x6.5x2



903312
SFH M3x12

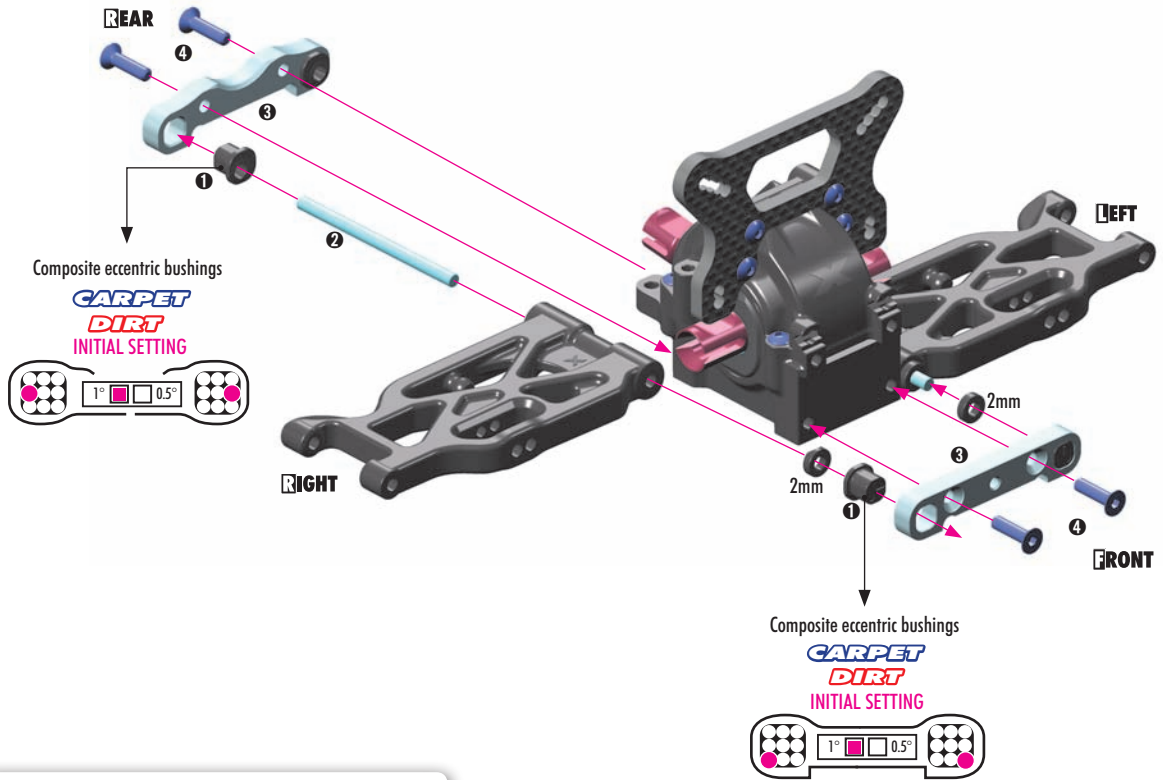

TIP **L=R**

If the suspension arm does not move freely use a HUDY Arm Reamer to size the holes of the arms.

Arm Reamer 3.0mm (HUDY #107633)

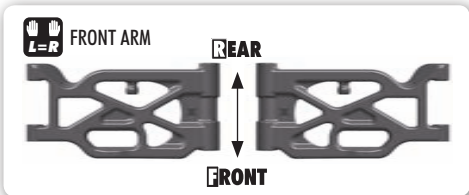

OPTION	SHORT FRONT SUSPENSION ARM			
	#362112	MEDIUM	OPTION	
	#362112-H	HARD	INCLUDED	
	#362112-G	GRAPHITE	OPTION	
OPTION	LONG FRONT SUSPENSION ARM			
	#362113-H	HARD	OPTION	
	#362113-G	GRAPHITE	OPTION	

SET-UP BOOK
KICK UP
ROLL CENTER
TRACK-WIDTH

ECCENTRIC BUSHINGS HAVE TWO DIFFERENT OFFSETS FROM THE CENTER.



The XRAY alu front lower suspension holders provide great range of adjustment for the front suspension. Using different combinations of eccentric bushings, fine adjustment of front kick-up, roll-center, and front track-width can be obtained. For more information about the influence of kick-up, front track-width, and roll centers on car handling, please refer to HUDY Set-up Book (#209100).

KICK-UP		
FF	FR	(°)
		=7°
		=6°
		=8°
		=6°
		=5°
		=7°
		=8°
		=7°
		=9°

ROLL CENTER		
FF	FR	(mm)
		= +0.75mm
		= 0mm
		= -0.75mm

TRACK-WIDTH		
FF	FR	(mm)
		= +1.5mm
		= 0mm
		= -1.5mm

The tables describe the amounts of adjustment using the center and outside positions of the eccentric bushings. The middle position eccentric bushings allow for finer adjustment increments.

The track-width is directly influenced by the size of the wheels and tires used.

TOTAL CASTER=C-HUB CASTER+KICK UP						
C-HUB CASTER	KICK-UP					
	6°	7°	8°	9°	10°	
6°	12°	13°	14°	15°	16°	
9°	15°	16°	17°	18°	19°	

Caster is the angle between the steering pivot axis and the vertical plane. Caster is affected not only by the C-Hub caster, but also by the front kick-up angle relative to the flat chassis bottom. The table indicates how kick up angle effects total caster.

The XB4's stock caster blocks are 9°, but 6° blocks are available as an option.

3. FRONT SUSPENSION

CARPET DIRT



901308
SB M3x8

2x L=R

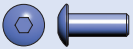
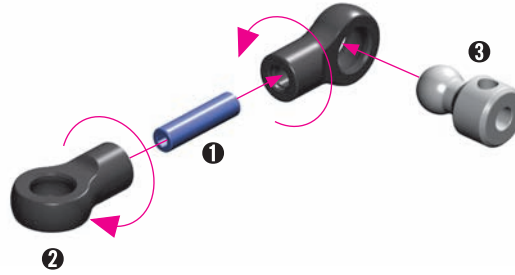
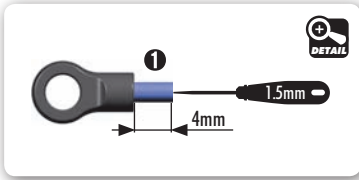

902308
SH M3x8

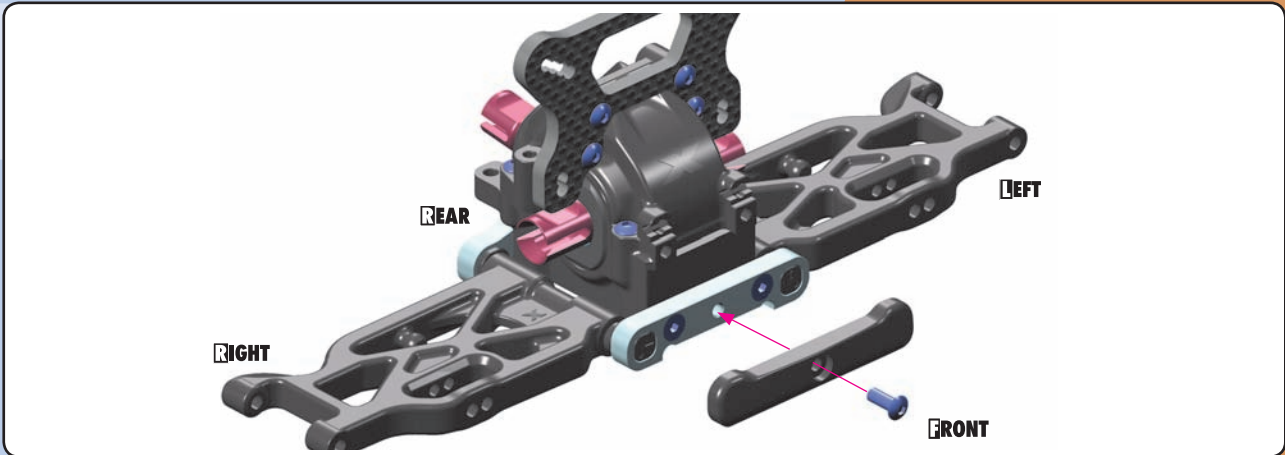

901303
SB M3x3



901304
SB M3x4

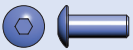

902308
SH M3x8

REAR

RIGHT **LEFT** **FRONT**

STEP 3 DETAIL

INITIAL SETTING
0-1mm

L=R

OPTION

ANTI-ROLL BARS		
#362470	1.0mm	OPTION
#362471	1.1mm	OPTION
#362472	1.2mm	INCLUDED
#362473	1.3mm	OPTION
#362474	1.4mm	OPTION
#362476	1.6mm	OPTION
#362478	1.8mm	INCLUDED
#362480	2.0mm	OPTION

DETAIL

Step 1 check for free movement.

DETAIL

Step 1
Loosen the 3x4 setscrew if the anti-roll bar does not turn freely.

SET-UP BOOK

ANTI-ROLL BAR

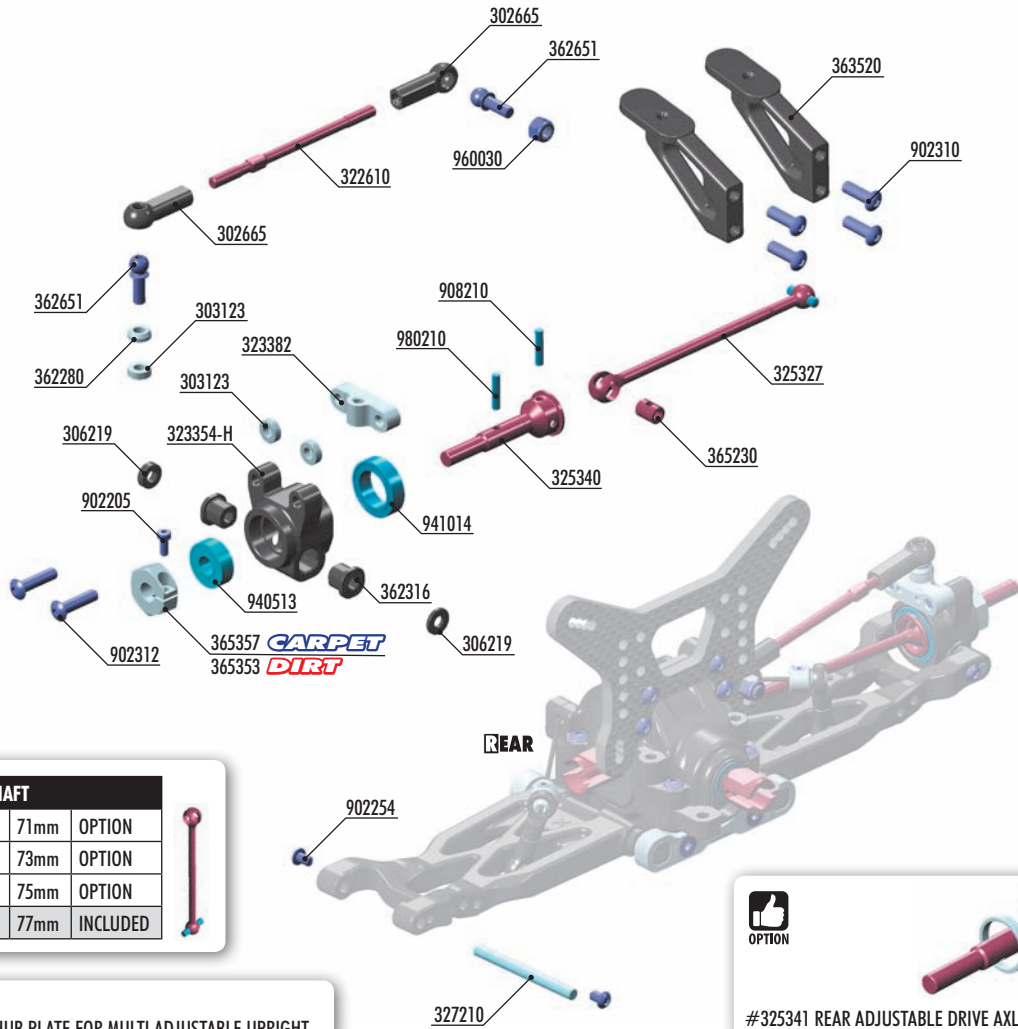

DRIVE SHAFT

#325323	71mm	OPTION
#325326	73mm	OPTION
#325324	75mm	OPTION
#325327	77mm	INCLUDED



#323381
ALU REAR HUB PLATE FOR MULTI ADJUSTABLE UPRIGHT
- SWISS 7075 T6



XRAY BALL-BEARING

#940512	5x12x4	OIL	OPTION
#941015	10x15x4	OIL	OPTION
#940513	5x12x4	GREASE	INCLUDED
#941014	10x15x4	GREASE	INCLUDED



ALU CONICAL SHIM

#362280	SILVER	INCLUDED
#362280-K	BLACK	OPTION
#362280-O	ORANGE	OPTION



REAR UPRIGHTS

#323354-H	COMPOSITE - H	INCLUDED
#323354-G	COMPOSITE - G	OPTION
#323355	ALU	OPTION



ALU NUTS M3

#296530-B	BLUE	OPTION
#296530-K	BLACK	OPTION
#296530-O	ORANGE	OPTION
#960031	SILVER	OPTION



#325341 REAR ADJUSTABLE DRIVE AXLE LB - HUDY SPRING STEEL™
#325390 ALU SHIM 10x12x2MM (2)



WHEEL HUBS 12MM

#365360	+4.5mm	6 SLOTS	OPTION
#365359	+3.75mm	5 SLOTS	OPTION
#365358	+3.0mm	4 SLOTS	OPTION
#365357	+2.25mm	3 SLOTS	INCLUDED
#365356	+1.5mm	2 SLOTS	OPTION
#365355	+0.75mm	1 SLOT	OPTION
#365353	0mm	0 SLOTS	INCLUDED
#365354	-0.75mm	Lightw.	OPTION
#365361	-1.25mm	Lightw.	OPTION



WHEEL HUBS 14MM

#365352	+0.75mm	OPTION
#365350	0mm	OPTION
#365351	-0.75mm	OPTION



BAG

04

- 302665 COMPOSITE BALL JOINT 4.9MM - CLOSED WITH HOLE (4)
- 303123 ALU SHIM 3x6x2.0MM (10)
- 306219 COMPOSITE SET OF SERVO SHIMS (4)
- 322610 ADJ. TURNBUCKLE M3 L/R 55 MM - SPRING STEEL (2)
- 323354-H COMPOSITE UPRIGHT REAR - HARD
- 323382 ALU REAR HUB PLATE FOR MULTI ADJ. UPRIGHT - 1-HOLE
- 325327 REAR DRIVE SHAFT 77MM WITH 2.5MM PIN - SPRING STEEL™
- 325340 REAR DRIVE AXLE LB - HUDY SPRING STEEL™
- 327210 FRONT SUSPENSION PIVOT PIN (2)
- 362280 ALU CONICAL SHIM 3x6x2.0MM (10)
- 362316 OPEN ECCENTRIC BUSHING SET (2)
- 362651 BALL END 4.9MM WITH THREAD 8MM (2)
- 363520 REAR WING POST - V2 (2)

- 365230 DRIVE SHAFT COUPLING - HUDY SPRING STEEL™
- 365353 ALU WHEEL HUB 12MM (2)
- 365357 ALU WHEEL HUB 12MM - OFFSET "+2.25MM" (2)

- 902205 HEX SCREW SH M2x5 (10)
- 902254 HEX SCREW SH M2.5x4 (10)
- 902310 HEX SCREW SH M3x10 (10)
- 902312 HEX SCREW SH M3x12 (10)
- 940513 BALL-BEARING 5x12x4 RUBBER SEALED - GREASE (2)
- 941014 BALL-BEARING 10x15x4 RUBBER SEALED - GREASE (2)
- 960030 NUT M3 (10)
- 980210 PIN 2x10 (10)

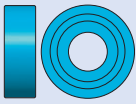

940513
BB 5x12x4



941014
BB 10x15x4



980210
P 2x10



902205
SH M2x5

2x

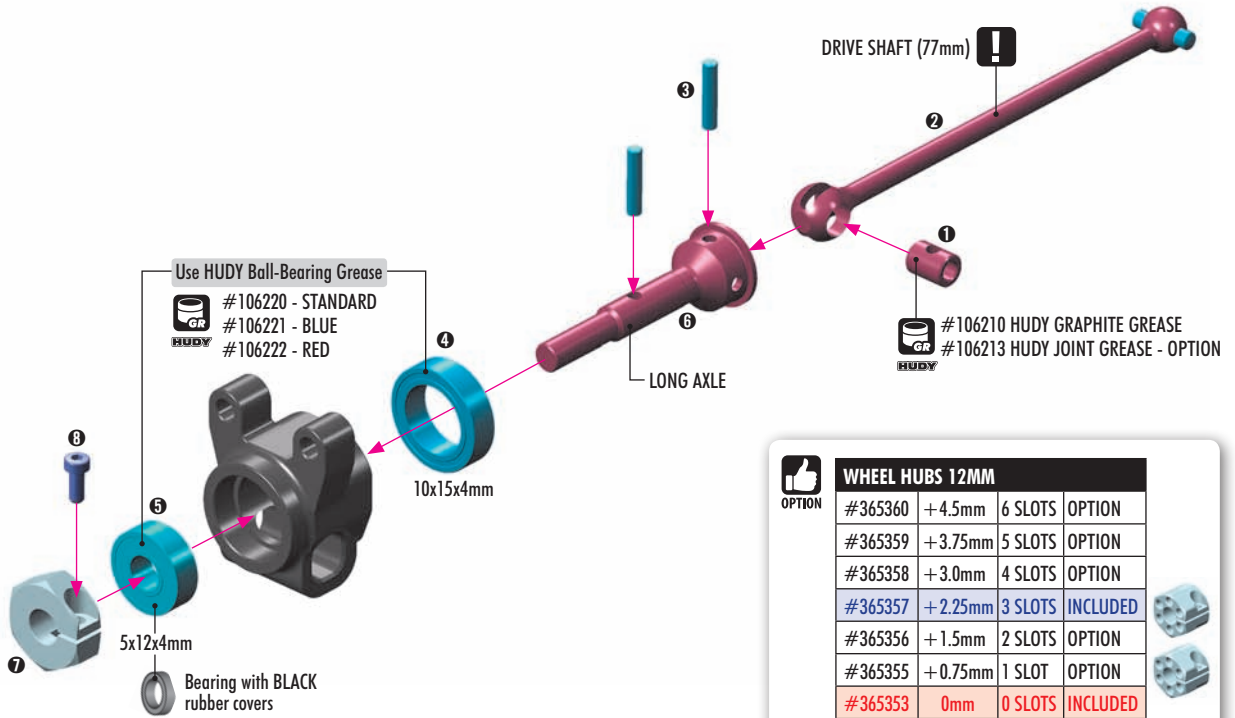

DRIVE SHAFT			
OPTION	#325323	71mm	OPTION
	#325326	73mm	OPTION
	#325324	75mm	OPTION
	#325327	77mm	INCLUDED

XRAY BALL-BEARING				
OPTION	#940512	5x12x4	OIL	OPTION
	#941015	10x15x4	OIL	OPTION
	#940513	5x12x4	GREASE	INCLUDED
	#941014	10x15x4	GREASE	INCLUDED

WHEEL HUBS 12MM				
OPTION	#365360	+4.5mm	6 SLOTS	OPTION
	#365359	+3.75mm	5 SLOTS	OPTION
	#365358	+3.0mm	4 SLOTS	OPTION
	#365357	+2.25mm	3 SLOTS	INCLUDED
	#365356	+1.5mm	2 SLOTS	OPTION
	#365355	+0.75mm	1 SLOT	OPTION
	#365353	0mm	0 SLOTS	INCLUDED
	#365354	-0.75mm	Lightw.	OPTION
	#365361	-1.25mm	Lightw.	OPTION

WHEEL HUBS 14MM			
OPTION	#365352	+0.75mm	OPTION
	#365350	0mm	OPTION
	#365351	-0.75mm	OPTION

OPTIONAL HEX HUB EFFECTS

Different offset hex hubs are used to increase or decrease the track-width.

LESS OFFSET

Rear - more traction
Front - more steering

MORE OFFSET

Rear - less traction
Front - less steering

REAR UPRIGHTS			
OPTION	#323354-H	HARD	INCLUDED
	#323354-G	GRAPHITE	OPTION
	#323355	ALU	OPTION



303123
SHIM 3x6x2



902312
SH M3x12

2x

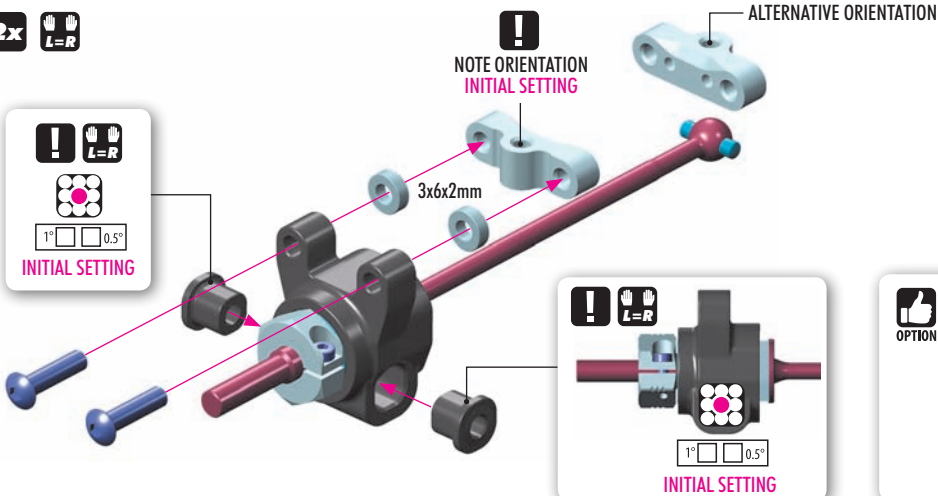

OPTION #323381
ALU REAR HUB PLATE FOR MULTI
ADJUSTABLE UPRIGHT - SWISS 7075 T6



4. REAR TRANSMISSION

CARPET DIRT

IO
306219
SHIM 3x6x1

IO
306219
SHIM 3x6x2

902254
SH M2.5x4

TIP Ensure that the rear upright moves freely. If it does not move freely, use sandpaper to thin both wheelbase adjustment shims.

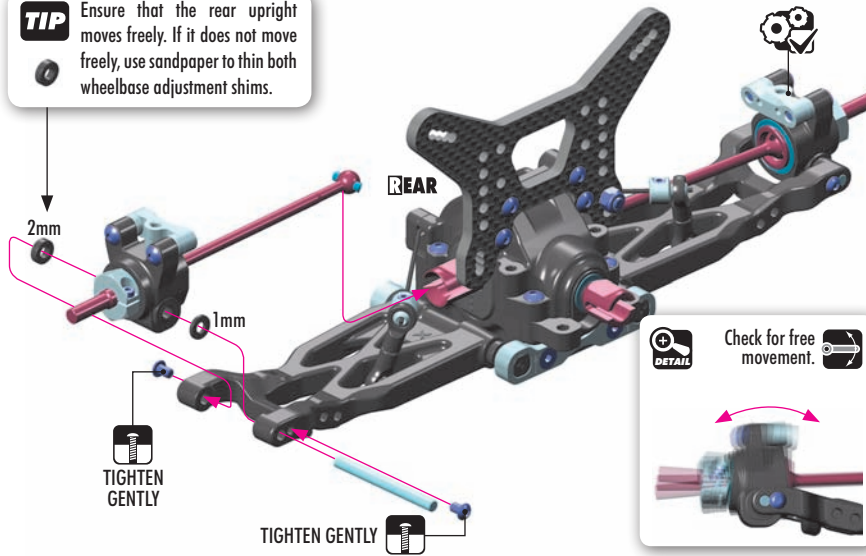

LONGER WHEELBASE

Adjustment Shim IN FRONT OF HUB moves hub rearward.

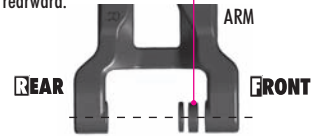

SHORTER WHEELBASE

Adjustment Shim BEHIND HUB moves hub forward.

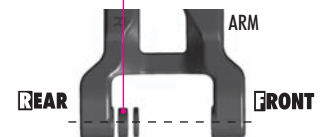

SET-UP BOOK

WHEELBASE

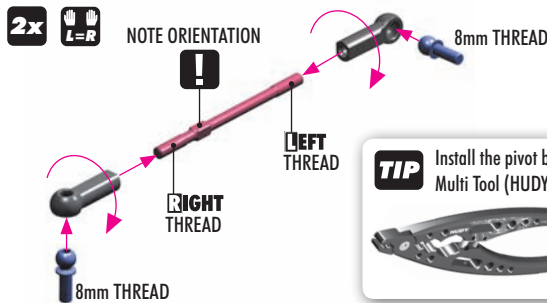

TIP Install the pivot balls with Professional Multi Tool (HUDY #183011).

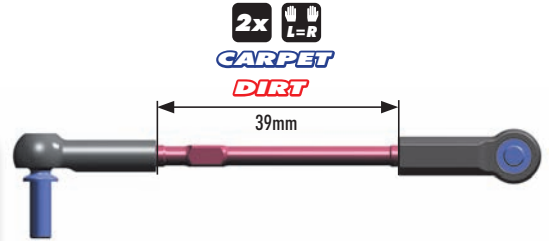

SET-UP BOOK

CAMBER

IO
303123
SHIM 3x6x2

362280
CON. SHIM 3x6x2

960030
N M3

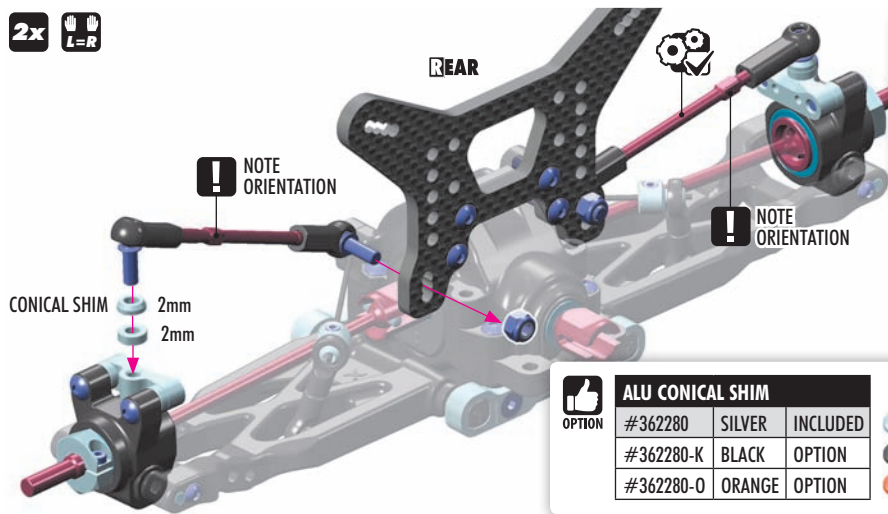

ALU NUTS M3		
OPTION #296530-B	BLUE	OPTION
OPTION #296530-K	BLACK	OPTION
OPTION #296530-O	ORANGE	OPTION
OPTION #960031	SILVER	OPTION

ALU CONICAL SHIM		
OPTION #362280	SILVER	INCLUDED
OPTION #362280-K	BLACK	OPTION
OPTION #362280-O	ORANGE	OPTION

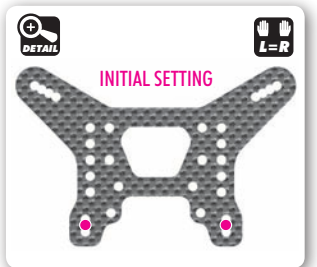

SET-UP BOOK

ROLL CENTER



902310
SH M3x10

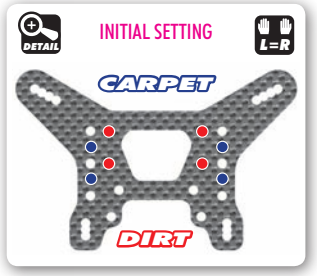
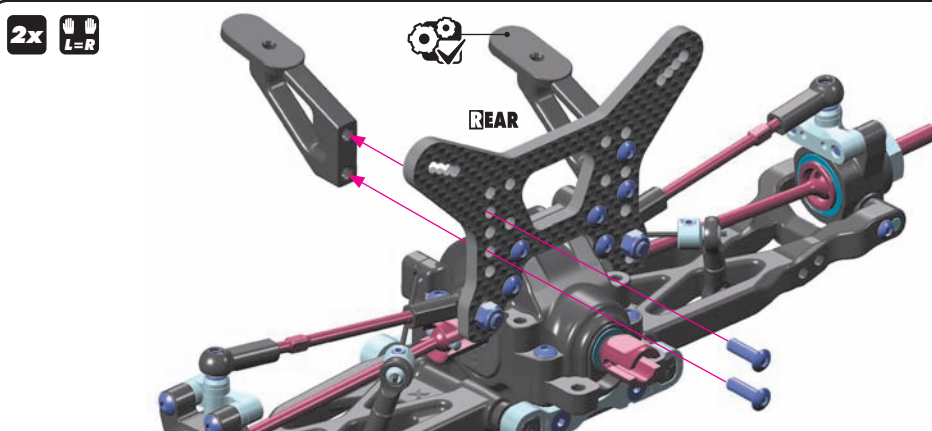



WHEEL HUBS 12MM			
#365360	+4.5mm	6 SLOTS	OPTION
#365359	+3.75mm	5 SLOTS	OPTION
#365358	+3.0mm	4 SLOTS	OPTION
#365357	+2.25mm	3 SLOTS	OPTION
#365356	+1.5mm	2 SLOTS	INCLUDED
#365355	+0.75mm	1 SLOT	OPTION
#365353	0mm	0 SLOTS	INCLUDED
#365354	-0.75mm	Lightw.	OPTION
#365361	-1.25mm	Lightw.	OPTION



XRAY BALL-BEARING			
#940510	5x10x4	OIL	OPTION
#940512	5x12x4	OIL	OPTION
#359050	5x10x4	GREASE	INCLUDED
#940513	5x12x4	GREASE	INCLUDED



DRIVE SHAFT COLLAR		
#365470	COMPOSITE	INCLUDED
#365471-K	ALU - BLACK	OPTION
#365471-O	ALU - ORANGE	OPTION



STEERING BLOCK		
#362250	MEDIUM	OPTION
#362250-H	HARD	INCLUDED
#362250-G	GRAPHITE	OPTION



C-HUBS		
#362210	RIGHT 9° - M	OPTION
#362210-H	RIGHT 9° - H	INCLUDED
#362210-G	RIGHT 9° - G	OPTION
#362211	RIGHT 6°	OPTION
#362234	ALU RIGHT 12°	OPTION
#362220	LEFT 9° - M	OPTION
#362220-H	LEFT 9° - H	INCLUDED
#362220-G	LEFT 9° - G	OPTION
#362221	LEFT 6°	OPTION
#362244	ALU LEFT 12°	OPTION



FRONT DRIVE SHAFT (2.5mm PIN)			
#365201	ECS	81mm	OPTION
#365202	ECS	83mm	OPTION
#365222	CVD	81mm	OPTION
#365225	CVD	83mm	INCLUDED
#365226	CVD	84mm	OPTION

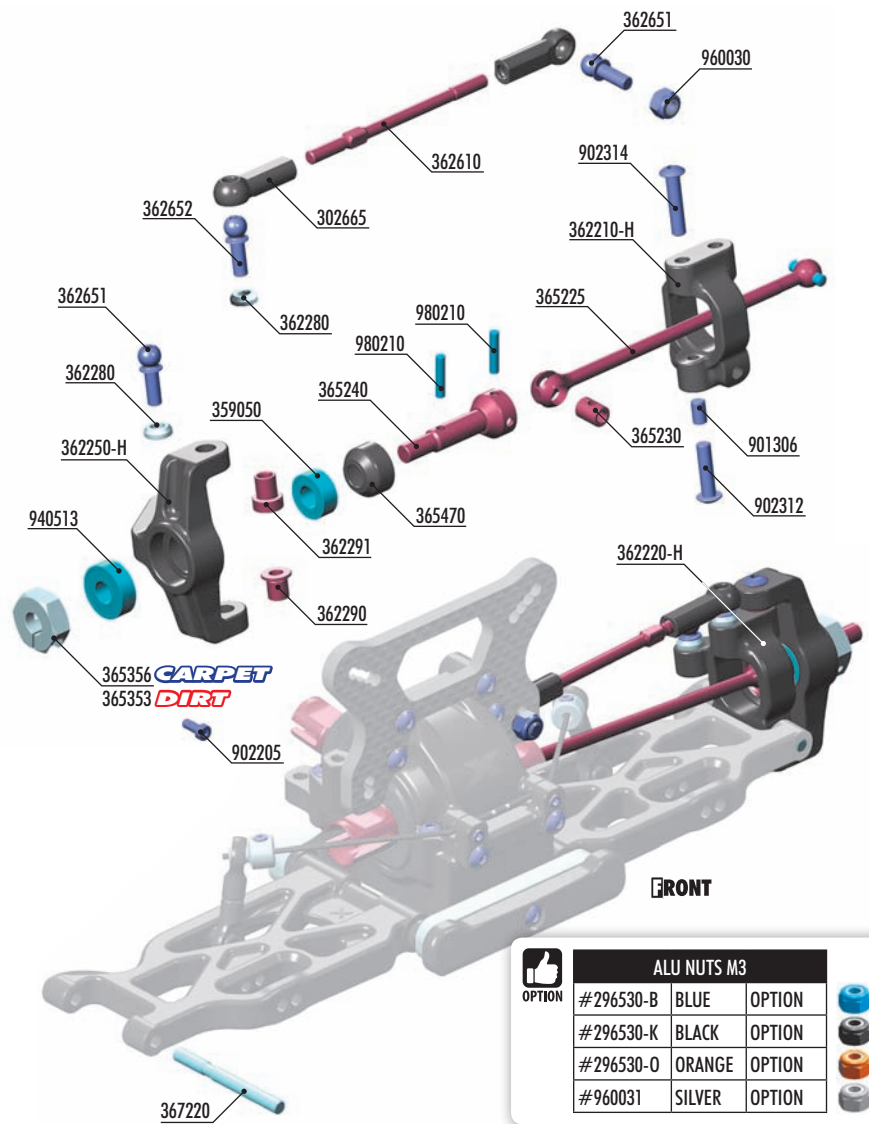

ALU NUTS M3		
#296530-B	BLUE	OPTION
#296530-K	BLACK	OPTION
#296530-O	ORANGE	OPTION
#960031	SILVER	OPTION



#360900
ALU STEERING BLOCKS & 7° C-HUBS - SET



BAG

04

- 302665 COMPOSITE BALL JOINT 4.9MM - CLOSED WITH HOLE (4)
- 362210-H COMPOSITE C-HUB 9° DEG. RIGHT - HARD
- 362220-H COMPOSITE C-HUB 9° DEG. LEFT - HARD
- 362250-H COMPOSITE STEERING BLOCK - HARD
- 362280 ALU CONICAL SHIM 3x6x2.0MM (10)
- 362290 STEEL STEERING BUSHING - SHORT (2)
- 362291 STEEL STEERING BUSHING - LONG (2)
- 362610 ADJ. TURNBUCKLE M3 L/R 50 MM - SPRING STEEL (2)
- 362651 BALL END 4.9MM WITH THREAD 8MM (2)
- 362652 BALL END 4.9MM WITH THREAD 10MM (2)
- 365225 FRONT DRIVE SHAFT 83MM WITH 2.5MM PIN - HUDY SPRING STEEL™
- 365230 DRIVE SHAFT COUPLING - HUDY SPRING STEEL™
- 365240 FRONT DRIVE AXLE - HUDY SPRING STEEL™

- 365353 ALU WHEEL HUB 12MM (2)
- 365356 ALU WHEEL HUB 12MM - OFFSET "+1.50MM" (2)
- 365470 COMPOSITE DRIVE SHAFT SAFETY COLLAR (3)
- 367220 FRONT ARM PIVOT PIN (2)
- 359050 BALL-BEARING 5x10x4 STEEL SEALED - GREASE (2)
- 901306 HEX SCREW SB M3x6 (10)
- 902205 HEX SCREW SH M2x5 (10)
- 902312 HEX SCREW SH M3x12 (10)
- 902314 HEX SCREW SH M3x14 (10)
- 940513 BALL-BEARING 5x12x4 RUBBER SEALED - GREASE (2)
- 960030 NUT M3 (10)
- 980210 PIN 2x10 (10)

980210
P 2x10

2x L=R

CVD DRIVE SHAFT (83mm)

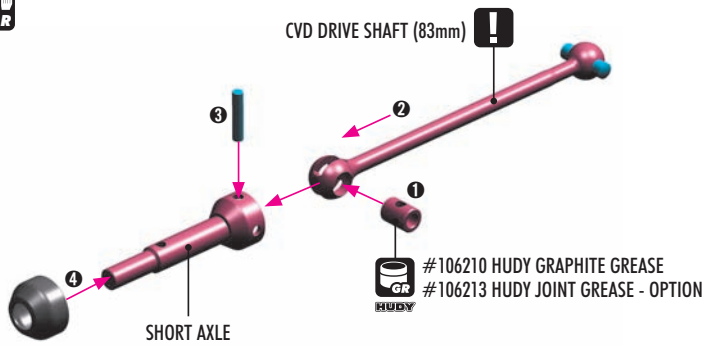

OPTION

FRONT DRIVE SHAFT (2.5mm PIN)

#365201	ECS	81mm	OPTION
#365202	ECS	83mm	OPTION
#365222	CVD	81mm	OPTION
#365225	CVD	83mm	INCLUDED
#365226	CVD	84mm	OPTION



359050
BB 5x10x4

940513
BB 5x12x4

Use HUDY Ball-Bearing Grease

#106220 - STANDARD
#106221 - BLUE
#106222 - RED

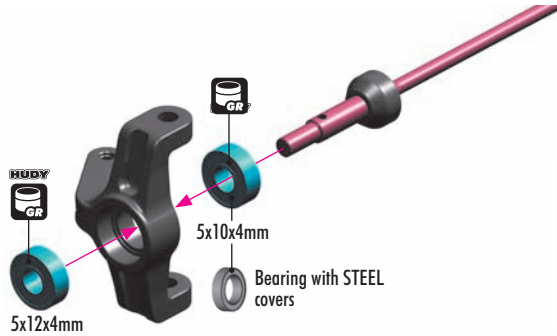

OPTION

XRAY BALL-BEARING

#940510	5x10x4	OIL	OPTION
#940512	5x12x4	OIL	OPTION
#359050	5x10x4	GREASE	INCLUDED
#940513	5x12x4	GREASE	INCLUDED

902205
SH M2x5

980210
P 2x10

2x L=R

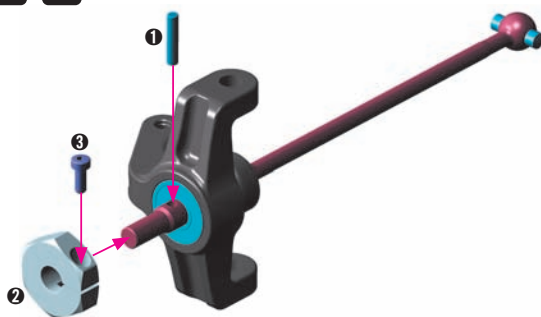

OPTION

WHEEL HUBS 12MM

#365360	+4.5mm	6 SLOTS	OPTION
#365359	+3.75mm	5 SLOTS	OPTION
#365358	+3.0mm	4 SLOTS	OPTION
#365357	+2.25mm	3 SLOTS	OPTION
#365356	+1.5mm	2 SLOTS	INCLUDED
#365355	+0.75mm	1 SLOT	OPTION
#365353	0mm	0 SLOTS	INCLUDED
#365354	-0.75mm	Lightw.	OPTION
#365361	-1.25mm	Lightw.	OPTION

OPTIONAL HEX HUB EFFECTS

Different off-set hex hubs are used to increase or decrease the track-width.

LESS OFF-SET

Rear - more traction
Front - more steering

MORE OFF-SET

Rear - less traction
Front - less steering

362280
CON. SHIM 3x6x2

902312
SH M3x12

902314
SH M3x14

IMPORTANT Be sure to use the shorter screw with shorter bushing and longer screw with longer bushing.

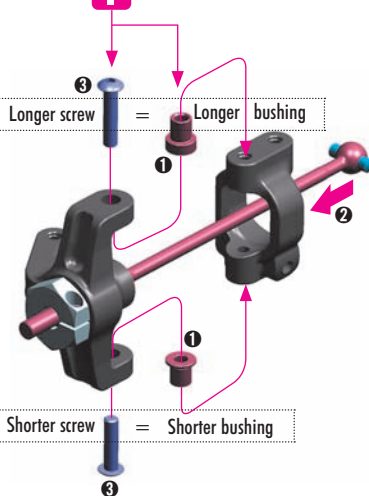

IMPORTANT (LEFT = RIGHT) L=R

When inserting the bushings, make sure that bushings are inserted equally on both right and left hub to give the same roll center position.



#360900
ALU STEER. BLOCKS & 7° C-HUBS - SET



SET-UP BOOK
CASTER
ROLL CENTER

901306
SB M3x6

2x
L=R

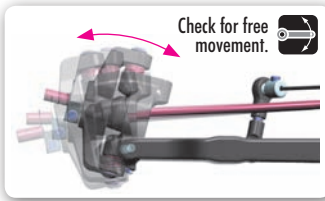

DO NOT OVERTIGHTEN

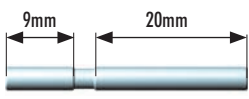

1:1 NOTE ORIENTATION

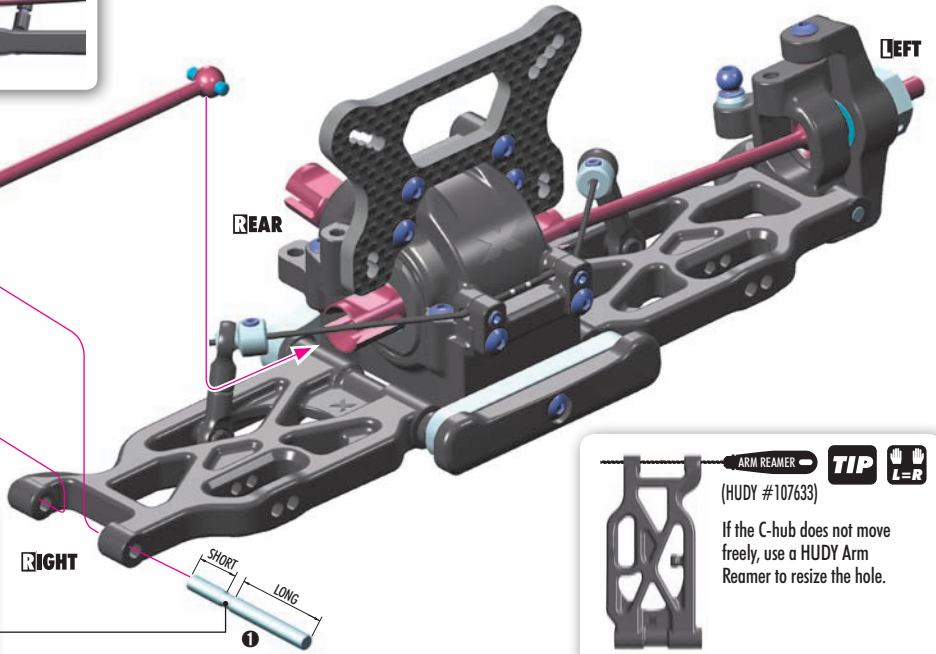

ARM REAMER TIP (HUDY #107633) L=R

If the C-hub does not move freely, use a HUDY Arm Reamer to resize the hole.

SET-UP BOOK
CAMBER

2x
L=R

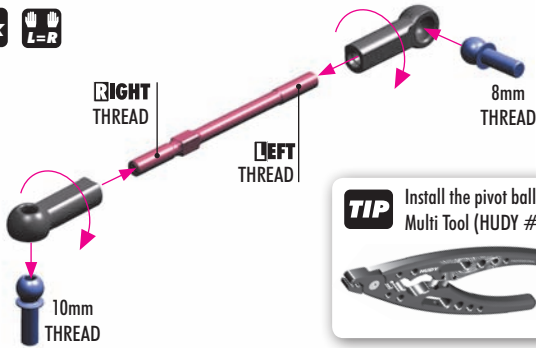

TIP Install the pivot balls with Professional Multi Tool (HUDY #183011).



2x
L=R

CARPET DIRT

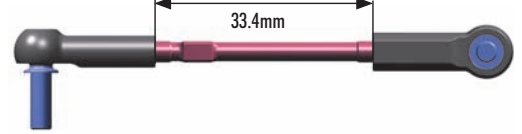

362280
CON. SHIM 3x6x2

960030
N M3

2x
L=R

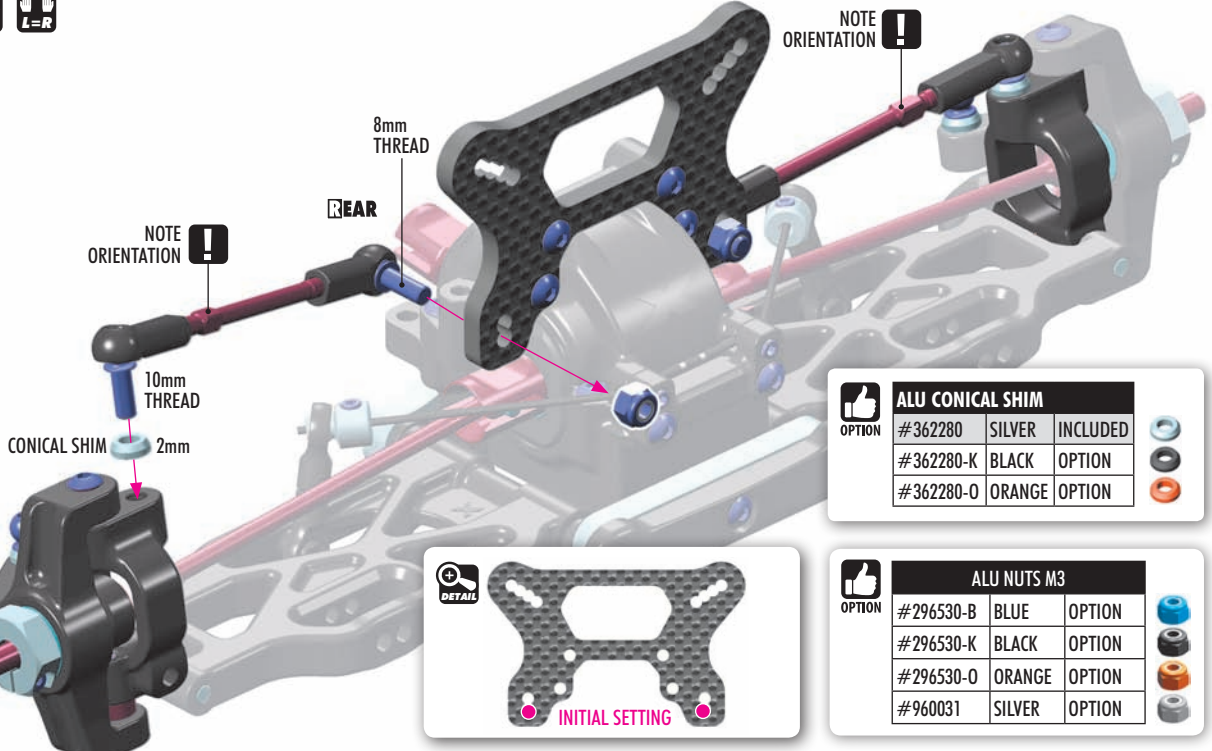

OPTION

ALU CONICAL SHIM			
#362280	SILVER	INCLUDED	
#362280-K	BLACK	OPTION	
#362280-O	ORANGE	OPTION	

OPTION

ALU NUTS M3			
#296530-B	BLUE	OPTION	
#296530-K	BLACK	OPTION	
#296530-O	ORANGE	OPTION	
#960031	SILVER	OPTION	

SET-UP BOOK
ROLL CENTER

4. FRONT & REAR ASSEMBLY

CARPET DIRT



ALU NUTS M3		
#296530-B	BLUE	OPTION
#296530-K	BLACK	OPTION
#296530-O	ORANGE	OPTION
#960031	SILVER	OPTION

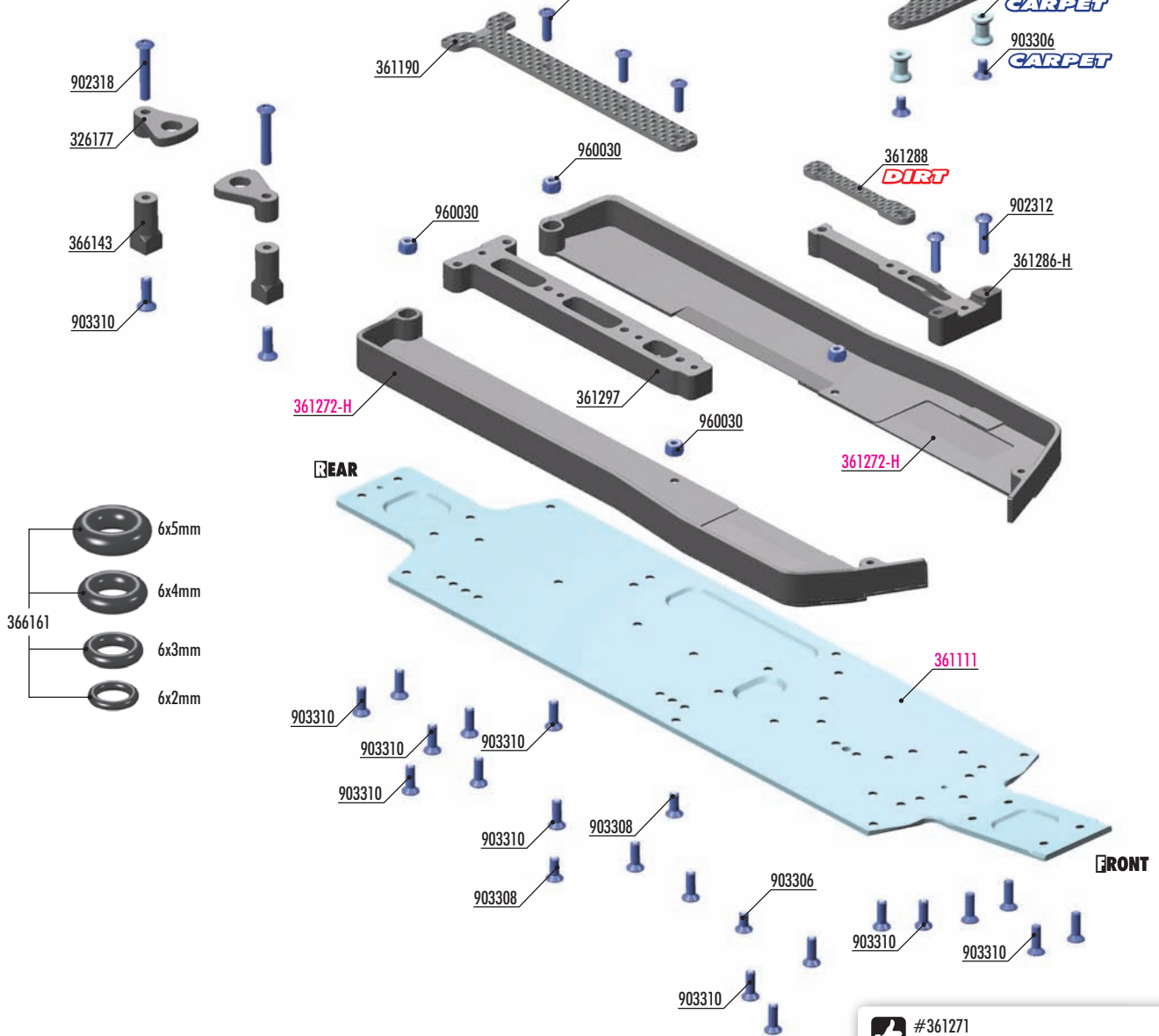

#361191
 BRASS CHASSIS BRACE REAR (40g)

#361295
 COMPOSITE CHASSIS BRACE REAR - MEDIUM

#361271
 XB4 CARBON FIBER CHASSIS SIDE GUARD L+R



- 326177 COMPOSITE BATTERY CLAMP (2)
- 361190 GRAPHITE CHASSIS BRACE UPPER DECK 2.2MM
- 361286-H COMPOSITE CHASSIS BRACE FRONT - HARD
- 361288 GRAPHITE CHASSIS WIRE COVER 2.2MM
- 361289 GRAPHITE CHASSIS T-BRACE - FRONT - 2.2MM
- 361297 COMPOSITE CHASSIS BRACE REAR - HARD
- 366011 ALU BRACE MOUNT - SWISS 7075 T6 (2)
- 366143 COMPOSITE BATTERY HOLDER STAND (2)

- 366161 SET OF O-RINGS (6x2, 6x3, 6x4, 6x5MM)
- 902306 HEX SCREW SH M3x6 (10)
- 902308 HEX SCREW SH M3x8 (10)

- 902310 HEX SCREW SH M3x10 (10)
- 902312 HEX SCREW SH M3x12 (10)
- 902314 HEX SCREW SH M3x14 (10)
- 902318 HEX SCREW SH M3x18 (10)
- 903306 HEX SCREW SFH M3x6 (10)
- 903308 HEX SCREW SFH M3x8 (10)
- 903310 HEX SCREW SFH M3x10 (10)
- 960030 NUT M3 (10)

- 361111 XB4'22 ALU CHASSIS - SWISS 7075 T6 - 2MM
- 361272-H COMPOSITE CHASSIS SIDE GUARDS L+R - HARD

4. FRONT & REAR ASSEMBLY

CARPET DIRT



903308
SFH M3x8

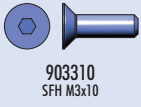

903310
SFH M3x10



960030
N M3

SET-UP BOOK

CHASSIS FLEX

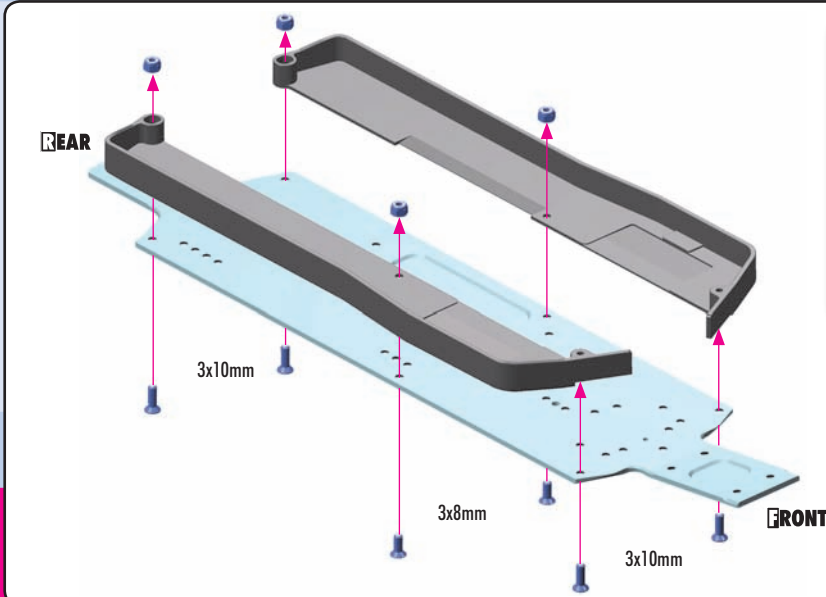

#361271
OPTION

XB4 CARBON FIBER CHASSIS SIDE GUARD L+R

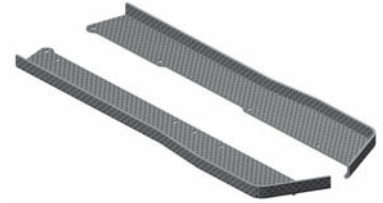

OPTION

ALU NUTS M3

#296530-B	BLUE	OPTION	
#296530-K	BLACK	OPTION	
#296530-O	ORANGE	OPTION	
#960031	SILVER	OPTION	



902306
SH M3x6



902308
SH M3x8



902310
SH M3x10



903306
SFH M3x6

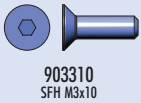

903310
SFH M3x10

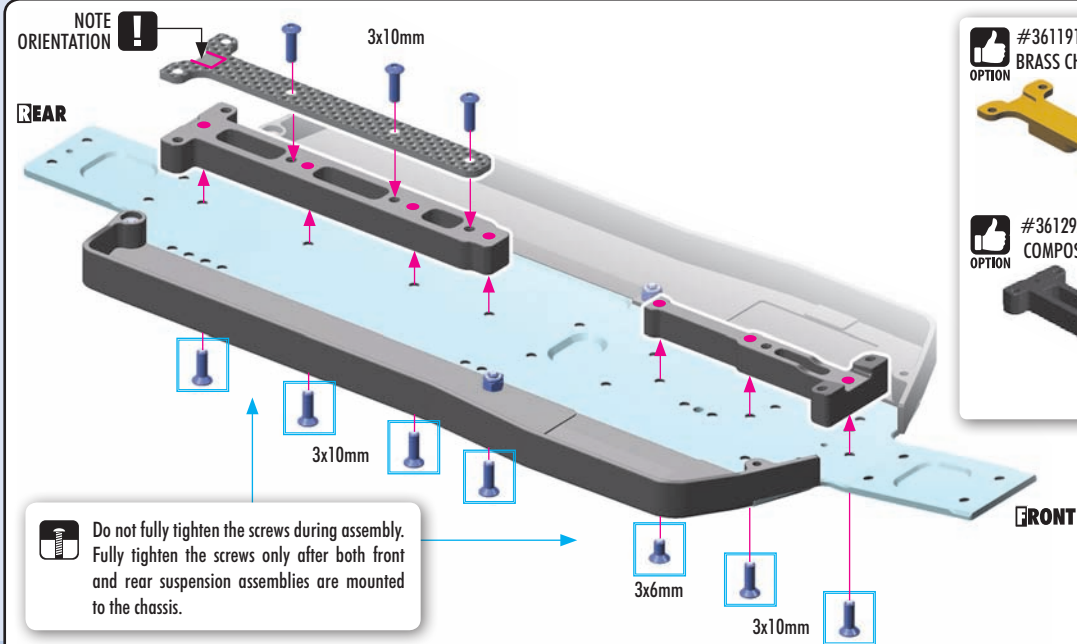

OPTION

#361191

BRASS CHASSIS BRACE REAR (40g)



OPTION

#361295

COMPOSITE CHASSIS BRACE REAR - MEDIUM



DIRT

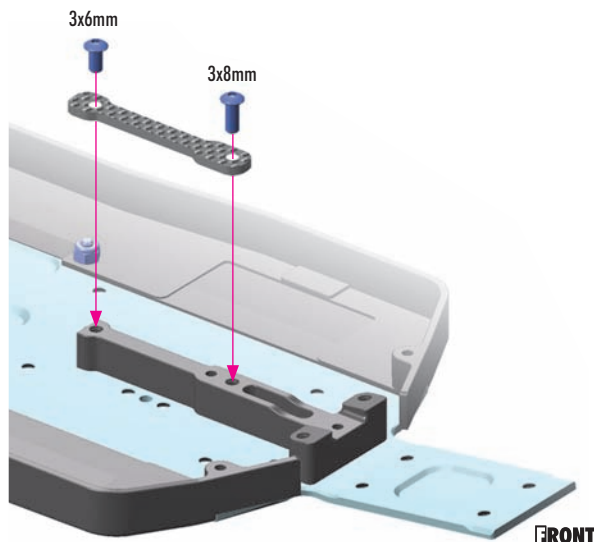

CARPET

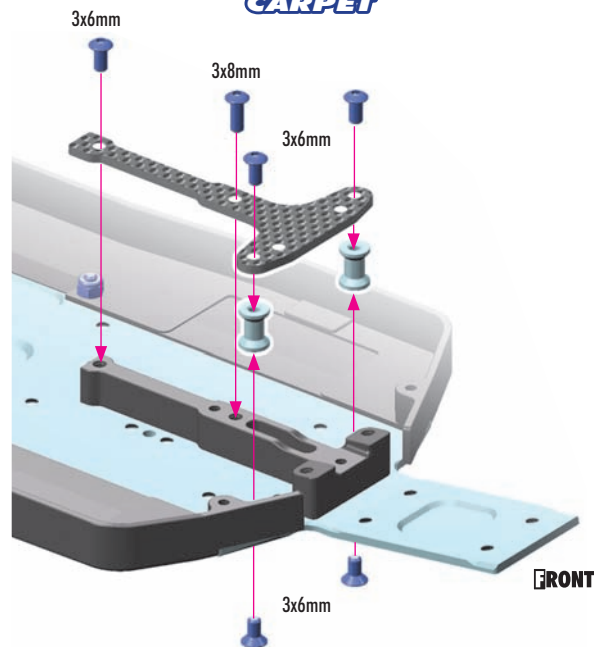



902314
SH M3x14



903310
SFH M3x10

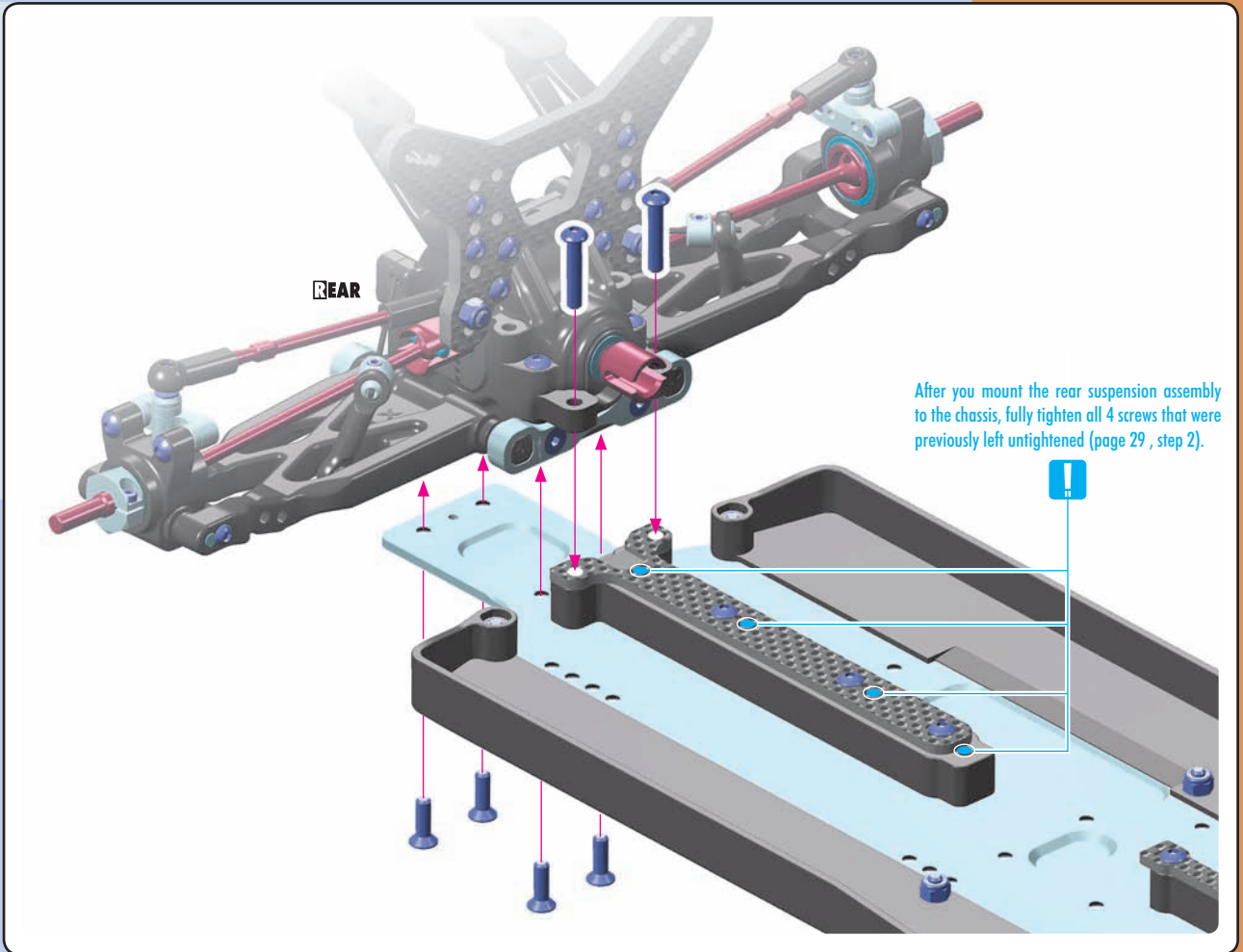

902312
SH M3x12



903310
SFH M3x10

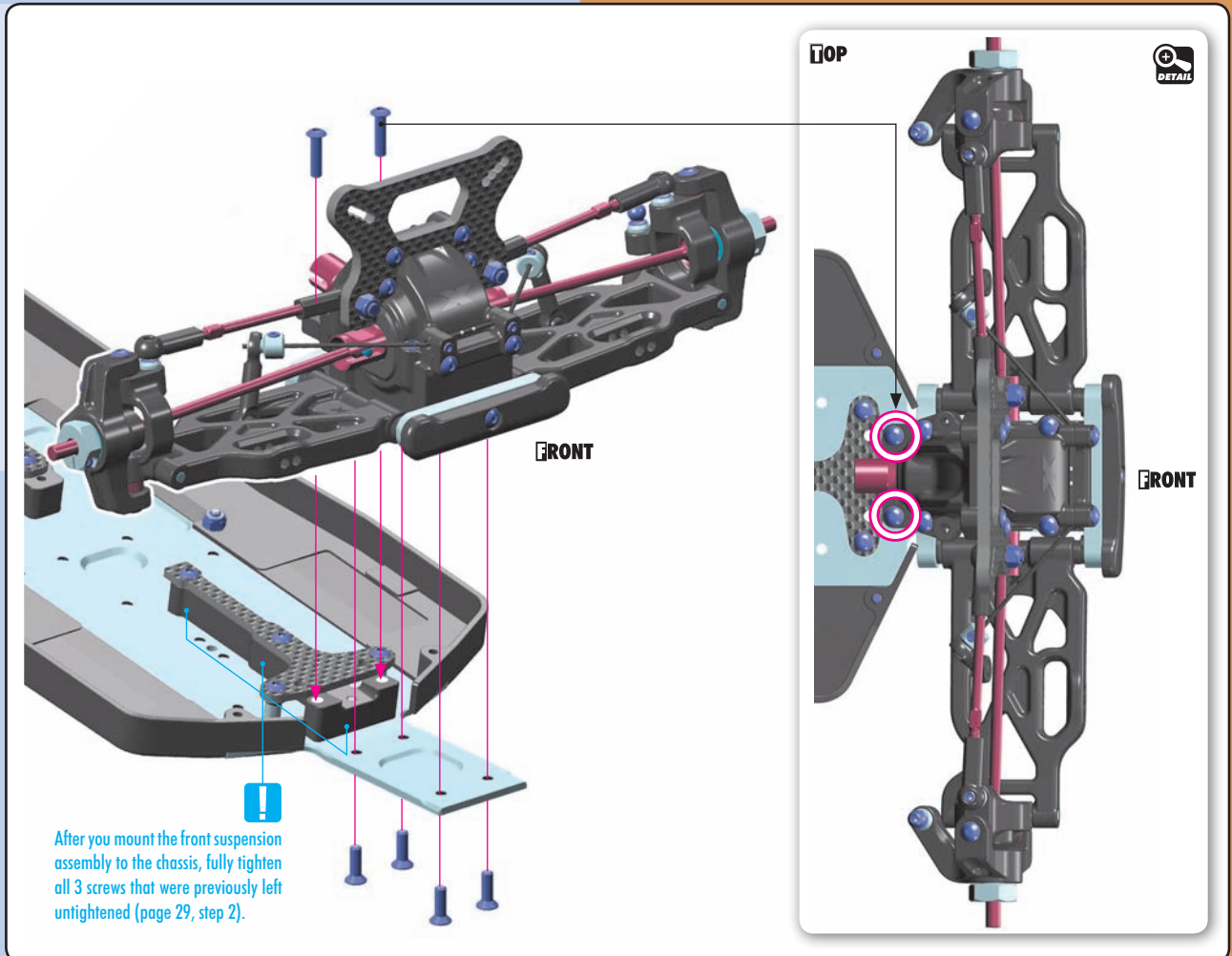



902318
SH M3x18



903310
SFH M3x10

! #366161

Choose the diameter of O-ring to best eliminate play between the battery and post without being too tight.



6x5mm



6x4mm



6x3mm



6x2mm

TIP Hold the battery holder with Professional Multi Tool (HUDY #183011).



Select the battery mount position to match the battery pack length.

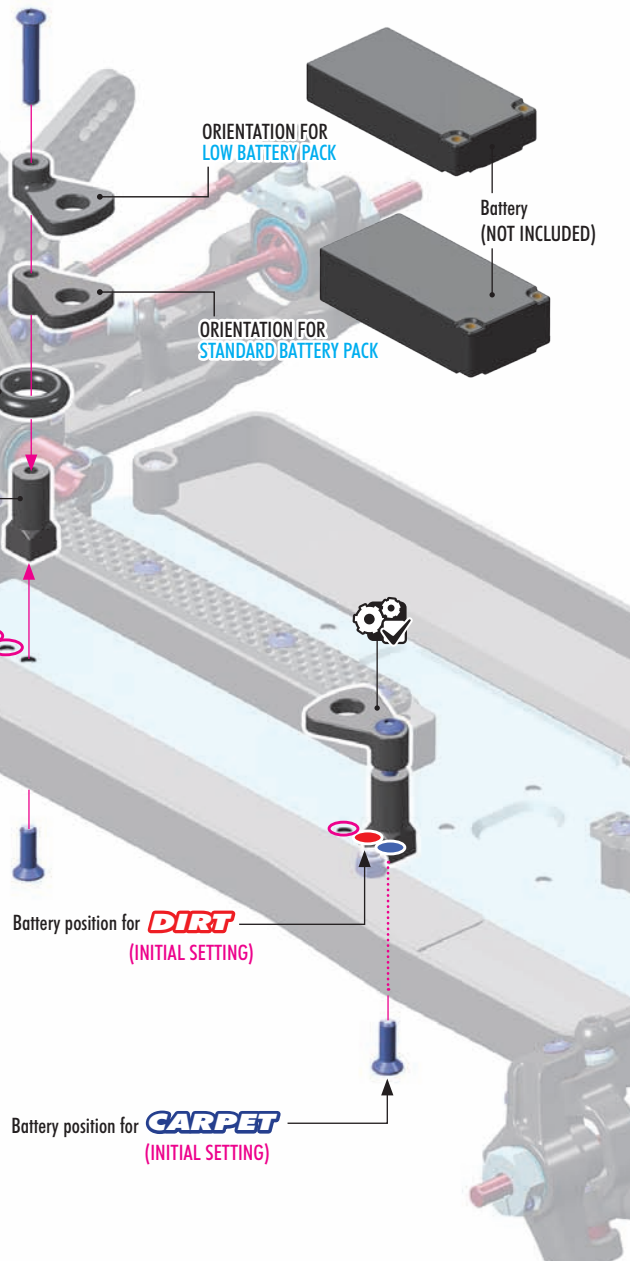
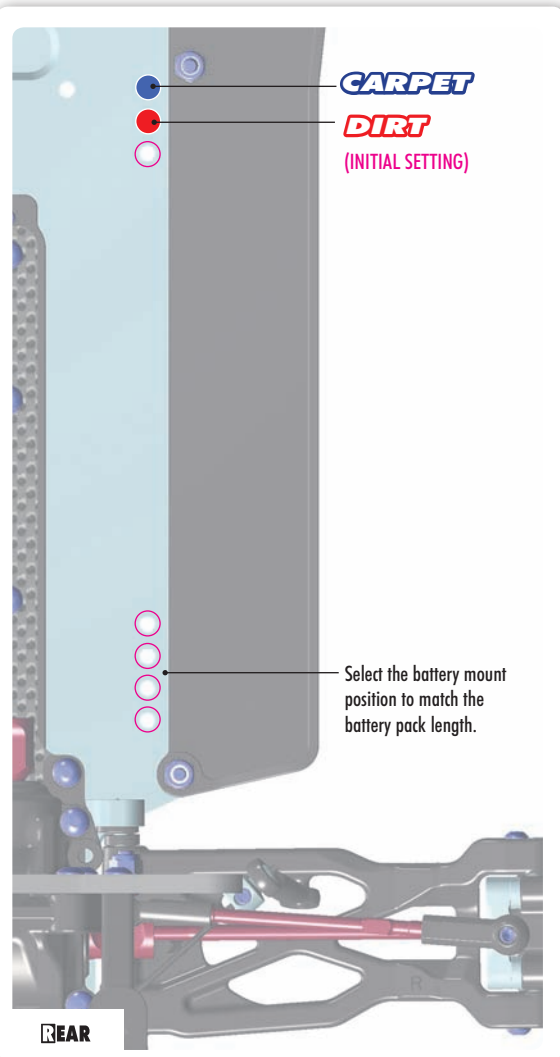

! #326181
OPTION STAINLESS STEEL BATTERY WEIGHT 35G



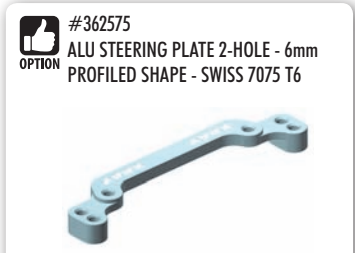
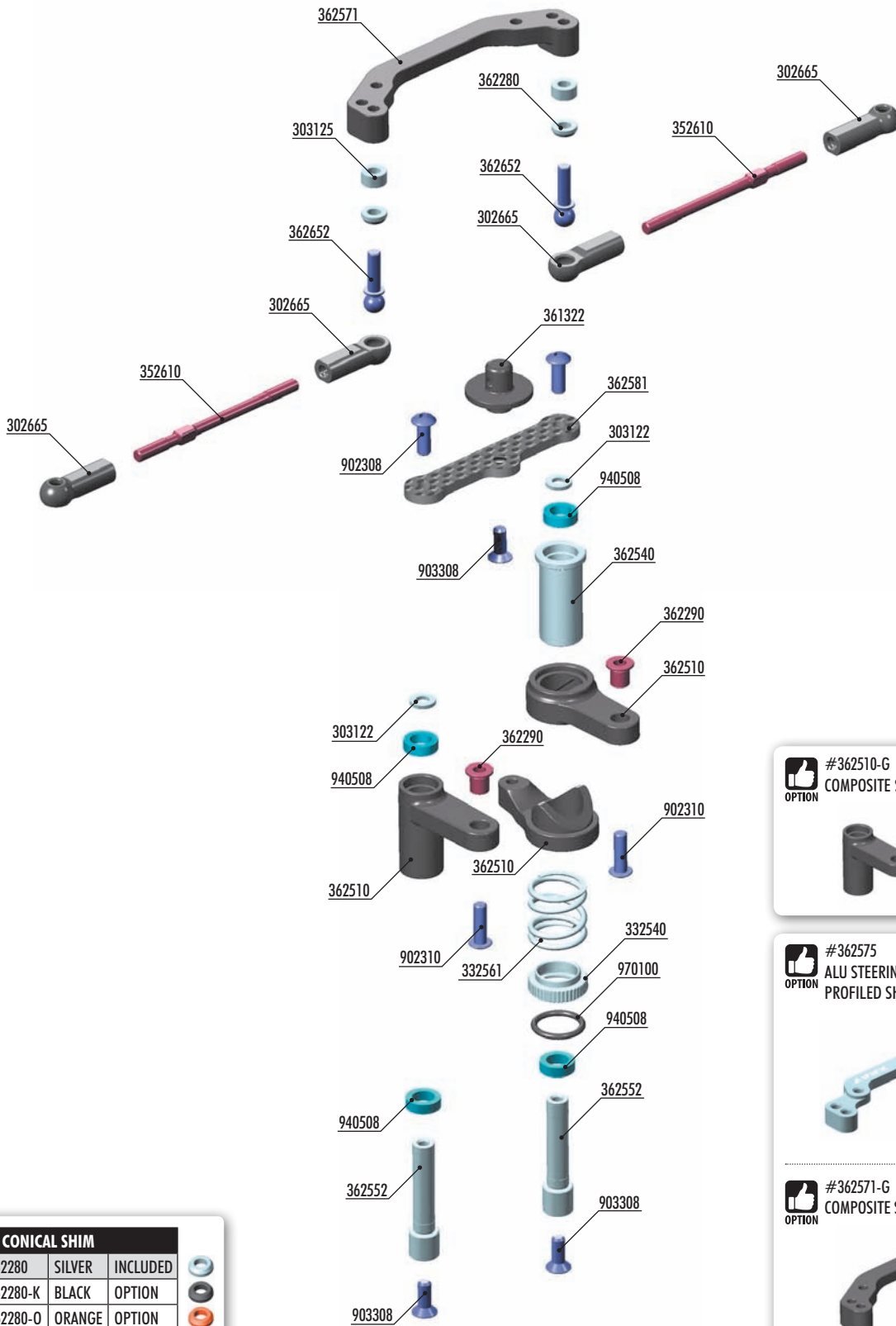

ALU CONICAL SHIM			
OPTION	#362280	SILVER	INCLUDED
	#362280-K	BLACK	OPTION
	#362280-O	ORANGE	OPTION

BAG
05

- 302665 COMPOSITE BALL JOINT 4.9MM - CLOSED WITH HOLE (4)
- 303122 ALU SHIM 3x6x1.0MM (10)
- 303125 ALU SHIM 3x6x3.0MM (10)
- 332540 ALU SERVO SAVER ADJUSTABLE NUT
- 332561 SERVO SAVER SPRING C=14
- 352610 ADJ. TURNBUCKLE M3 L/R 45MM - SPRING STEEL (2)
- 361322 BODY MOUNT - EXTRA-SHORT
- 362280 ALU CONICAL SHIM 3x6x2.0MM (10)
- 362290 STEEL STEERING BUSHING - SHORT (2)
- 362510 COMPOSITE SERVO SAVER
- 362540 ALU SERVO SAVER MAIN SHAFT

- 362552 SERVO SAVER PIVOT SHAFT +5MM (2)
- 362571 COMPOSITE STEERING PLATE
- 362581 STEERING BRACE 2.0MM GRAPHITE
- 362652 BALL END 4.9MM WITH THREAD 10MM (2)
- 902308 HEX SCREW SH M3x8 (10)
- 902310 HEX SCREW SH M3x10 (10)
- 903308 HEX SCREW SFH M3x8 (10)
- 940508 BALL-BEARING 5x8x2.5 RUBBER SEALED - OIL (2)
- 970100 O-RING 10 x 1.5 (10)



970100
O 16x1.5

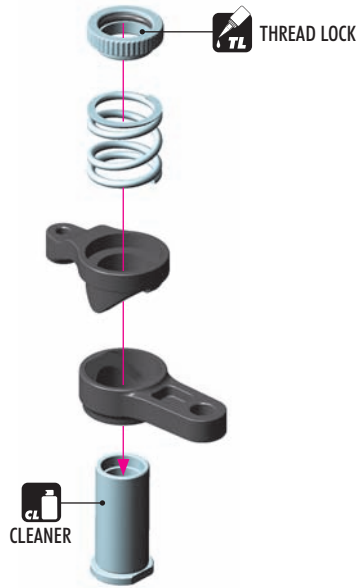

TL THREAD LOCK

CL CLEANER

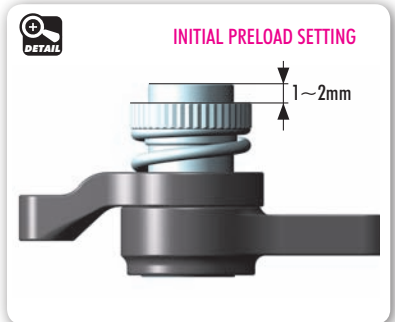

DETAIL

INITIAL PRELOAD SETTING

1~2mm

SET-UP BOOK

SERVO SAVER



902310
SH M3x10

NOTE ORIENTATION

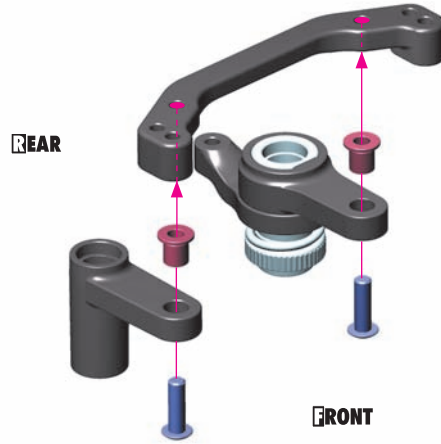

REAR

FRONT



OPTION

STEERING PLATE

#362571	HARD	INCLUDED
#362571-G	GRAPHITE	OPTION
#362575	ALU	OPTION



Increases steering precision and predictability and is recommended for use in high-traction conditions. Includes extra Ackermann positions for very precise steering adjustment.



303122
SHIM 3x6x1



902308
SH M3x8



903308
SFH M3x8



940508
BB 5x8x2.5

NOTE ORIENTATION

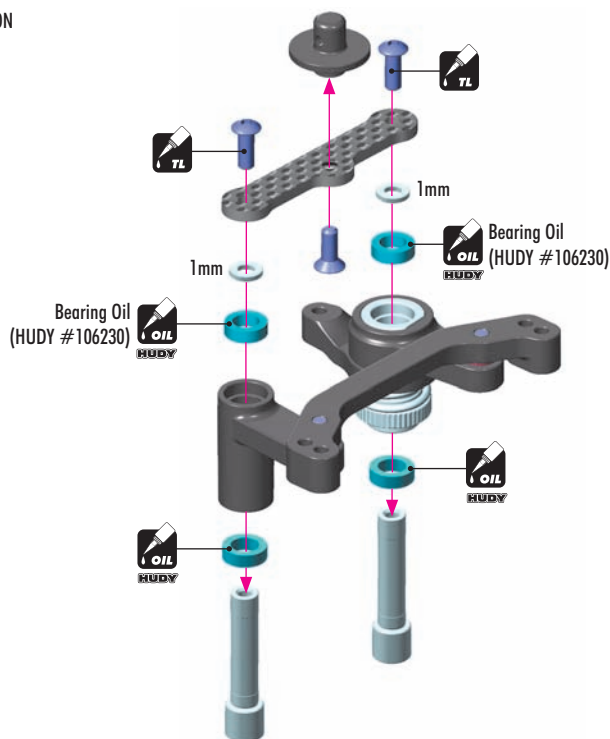

TL

1mm

Bearing Oil (HUDY #106230)

1mm

Bearing Oil (HUDY #106230)

OIL HUDY

OIL HUDY

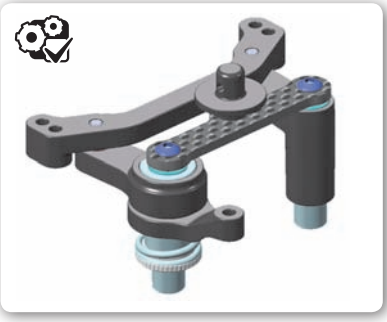

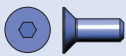

903308
SFH M3x8

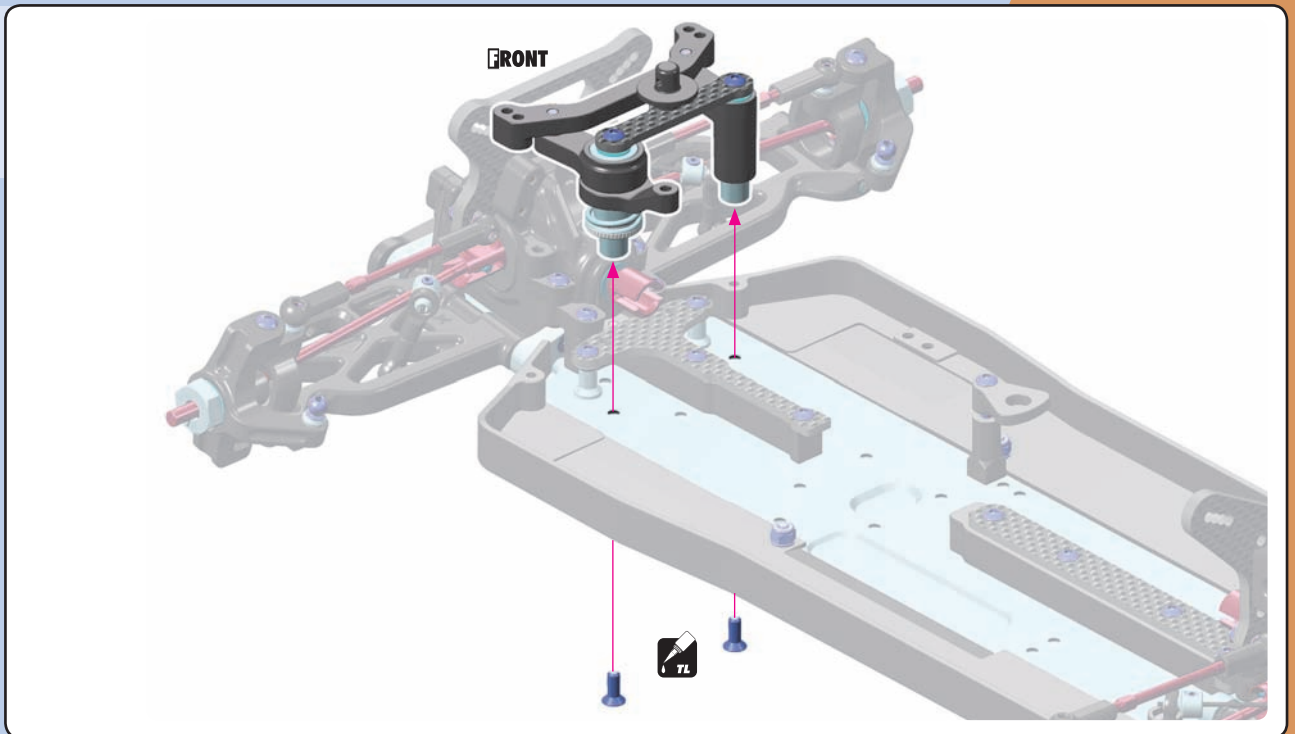

2x L=R

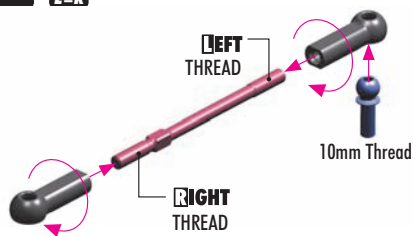

TIP Install the pivot balls with Professional Multi Tool (HUDY #183011).



2x L=R



303125
SHIM 3x6x3



362280
CON. SHIM 3x6x2

2x L=R

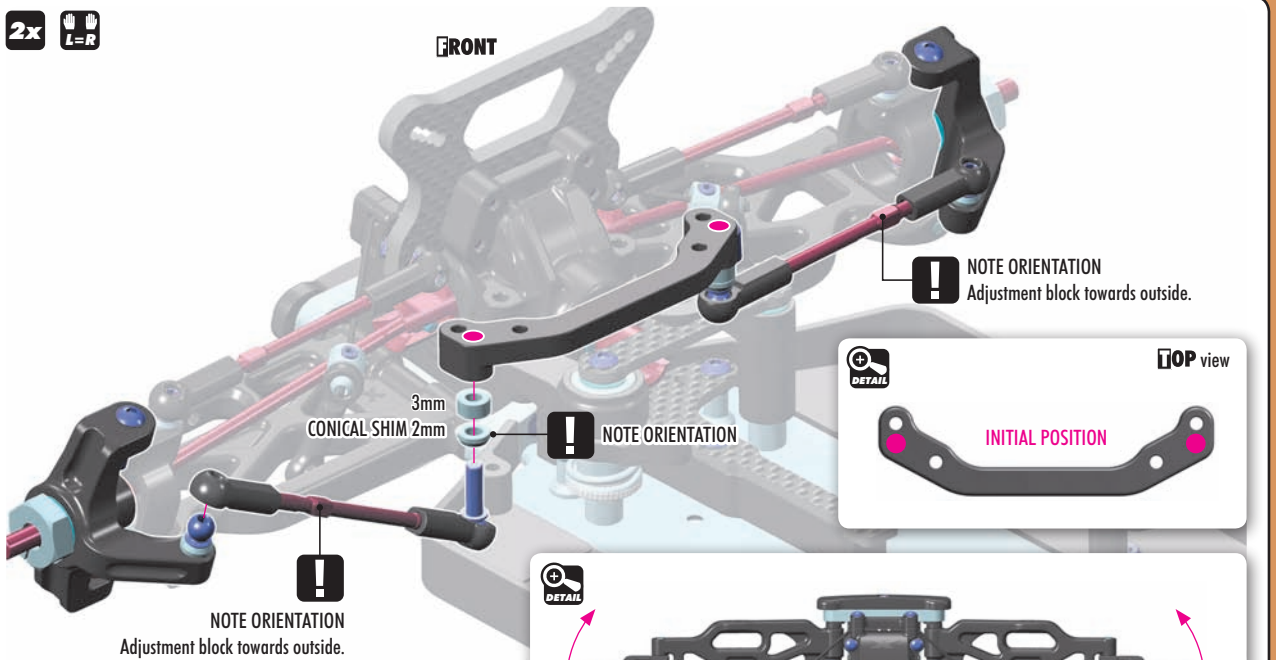

OPTION	ALU CONICAL SHIM		
#362280	SILVER	INCLUDED	
#362280-K	BLACK	OPTION	
#362280-O	ORANGE	OPTION	

Check for free movement.

Check for free movement.

SET-UP BOOK
ACKERMANN
BUMP STEER
TOE-IN

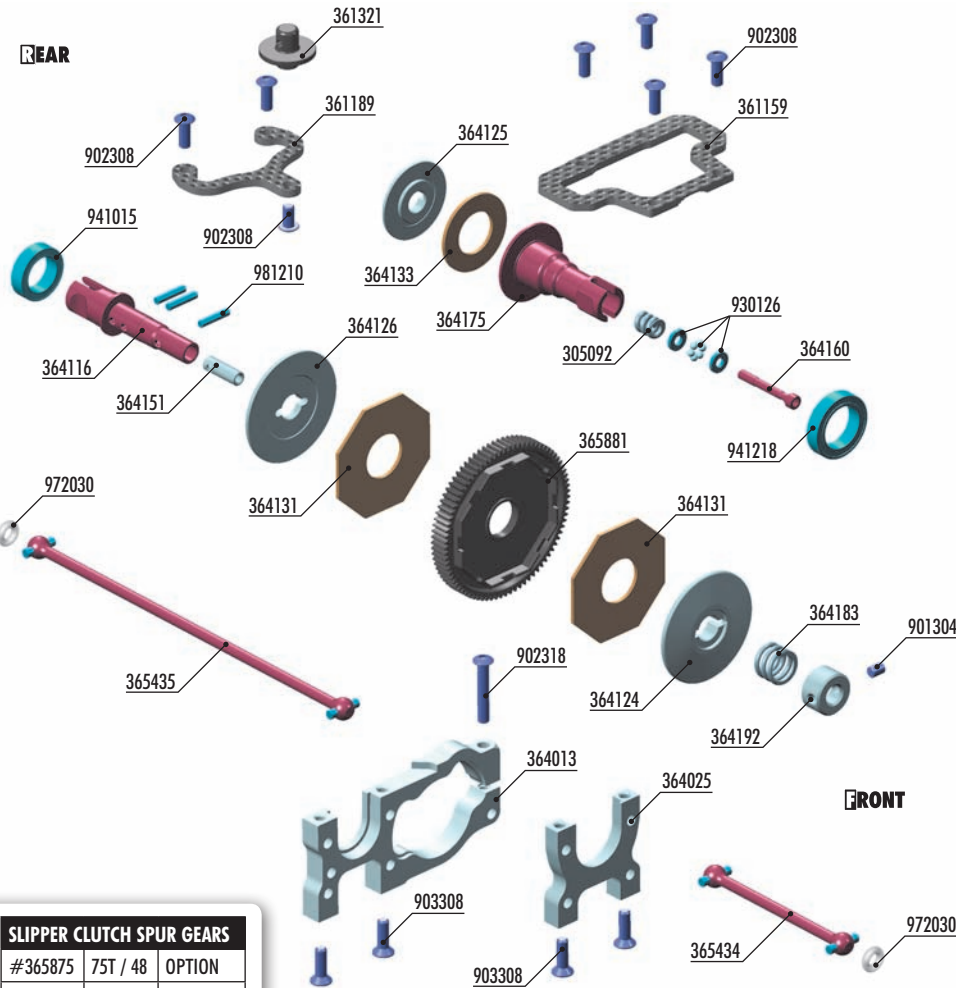

CENTER DIFF CONVERSION OPTION

- #365101 XRAY XB4 ACTIVE DIFF. CENTER - SET
- #364904 XRAY XB4 CENTER DIFF. - SET



- #364024 ALU CENTRAL BULKHEAD
- #364023 COMPOSITE CENTRAL BULKHEAD



- #365436 CENTRAL DOGBONE DRIVE SHAFT 65MM - HUDY SPRING STEEL™



- #361176 GRAPHITE CENTER UPPER DECK - V2



SLIPPER CLUTCH SPUR GEARS		
#365875	75T / 48	OPTION
#365878	78T / 48	OPTION
#365881	81T / 48	INCLUDED
#365884	84T / 48	OPTION
#365887	87T / 48	OPTION

BAG 06

- | | | | |
|--------|--|--------|--|
| 305092 | BALL DIFFERENTIAL SPRING | 364183 | SLIPPER CLUTCH SPRING C=50 - BLACK |
| 361159 | GRAPHITE CENTER UPPER DECK 2.2MM | 364192 | ALU NUT FOR ONE-WAY SLIPPER CLUTCH |
| 361189 | GRAPHITE REAR BODY POST HOLDER 2.2MM | 365434 | CENTRAL DOGBONE DRIVE SHAFT 47MM - HUDY SPRING STEEL™ |
| 361321 | BODY MOUNT - SHORT + SHIMS - SET | 365435 | CENTRAL DOGBONE DRIVE SHAFT 117MM - HUDY SPRING STEEL™ |
| 364013 | ALU MOTOR BULKHEAD - LOWER | 365881 | COMPOSITE SLIPPER CLUTCH SPUR GEAR 81T / 48 - GRAPHITE |
| 364025 | ALU CENTRAL BULKHEAD - SWISS 7075 T6 | 901304 | HEX SCREW SB M3x4 (10) |
| 364116 | ONE-WAY SLIPPER CLUTCH SHAFT - HUDY SPRING STEEL™ | 902308 | HEX SCREW SH M3x8 (10) |
| 364124 | ALU PLATE FOR ONE-WAY SLIPPER CLUTCH - FRONT - SWISS 7075 T6 | 902318 | HEX SCREW SH M3x18 (10) |
| 364125 | ALU PLATE FOR ONE-WAY SLIPPER CLUTCH FOR OUTDRIVE - SWISS 7075 T6 | 903308 | HEX SCREW SFH M3x8 (10) |
| 364126 | ALU PLATE FOR ONE-WAY SLIPPER CLUTCH - REAR - SWISS 7075 T6 | 930126 | CARBIDE BALL-BEARING AXIAL 2.6x6x1 |
| 364131 | SLIPPER CLUTCH PAD SLS - SOFT (3) | 941015 | BALL-BEARING 10x15x4 RUBBER SEALED - OIL (2) |
| 364133 | SLIPPER CLUTCH ONE-WAY OUTDRIVE PAD SLS - SOFT (2) | 941218 | BALL-BEARING 12x18x4 RUBBER SEALED - OIL (2) |
| 364151 | STEEL BUSHING FOR ONE-WAY SLIPPER CLUTCH | 972030 | SILICONE O-RING 3x2 (10) |
| 364160 | SCREW FOR ONE-WAY SLIPPER CLUTCH ADJUSTMENT - HUDY SPRING STEEL™ | 981210 | PIN 2x10 (10) |
| 364175 | OUTDRIVE ADAPTER WITH PRESSED ONE-WAY BEARING - HUDY SPRING STEEL™ | | |

981210
P 2x10

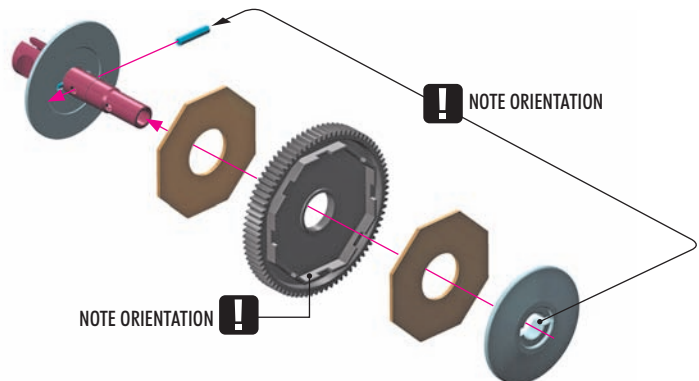
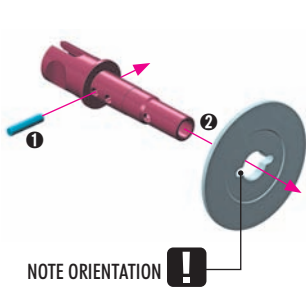

6. SLIPPER CLUTCH ASSEMBLY

CARPET

901304
SB M3x4

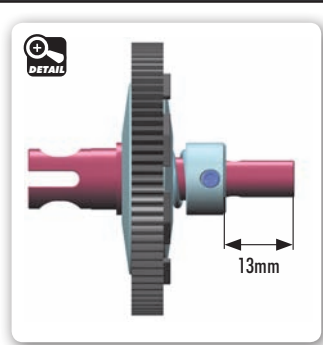
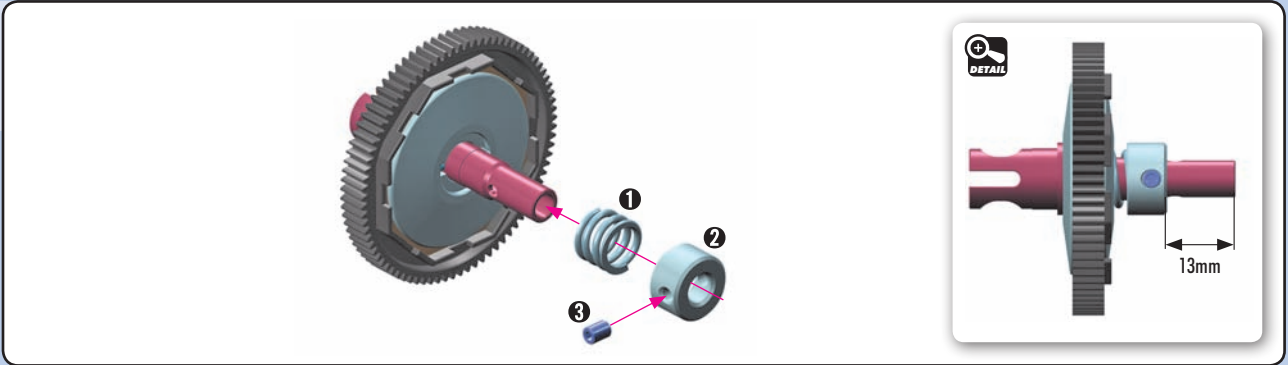

980210
P 2x10

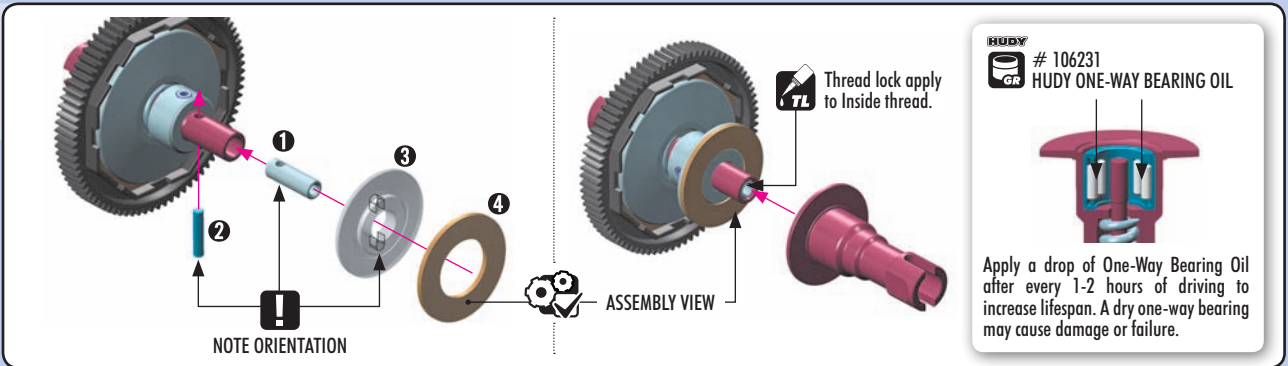

930126
BA 2.6x6x1

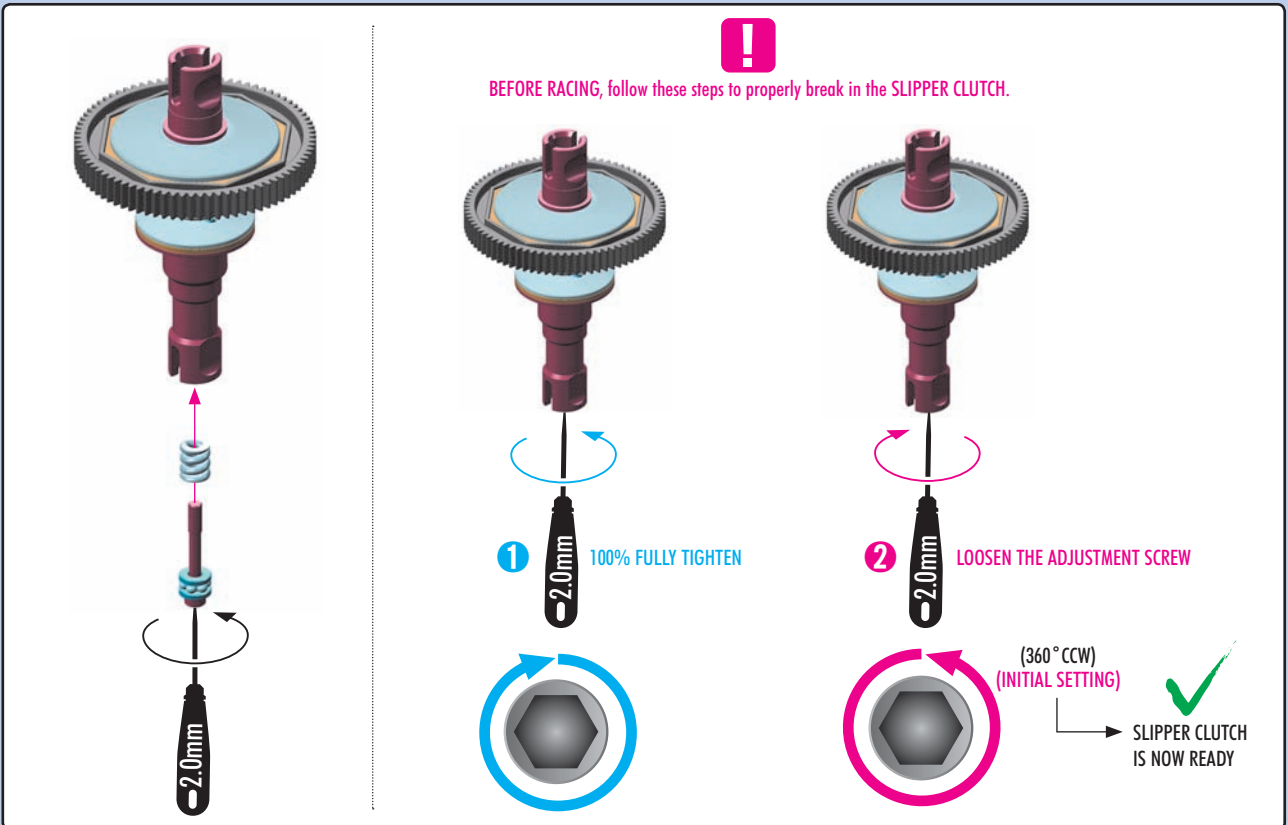
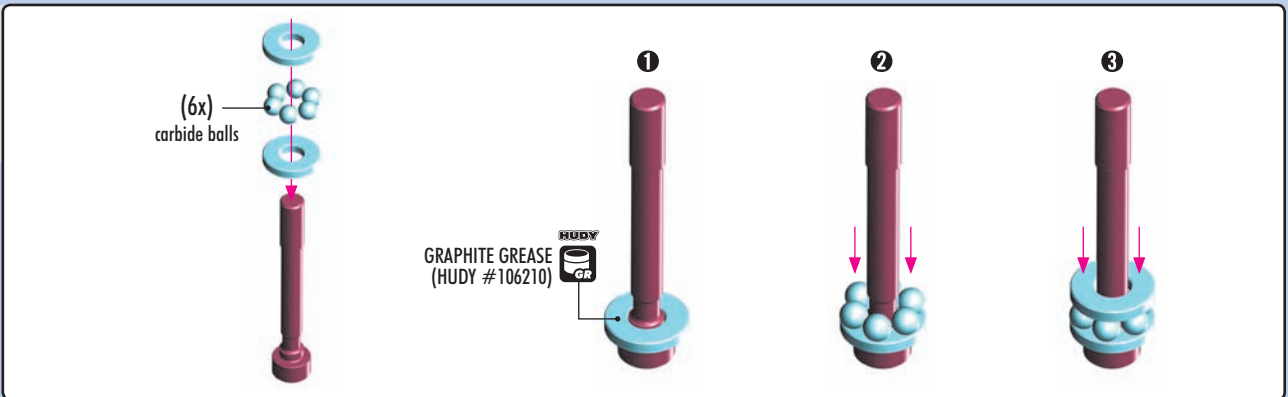

6. SLIPPER CLUTCH ASSEMBLY

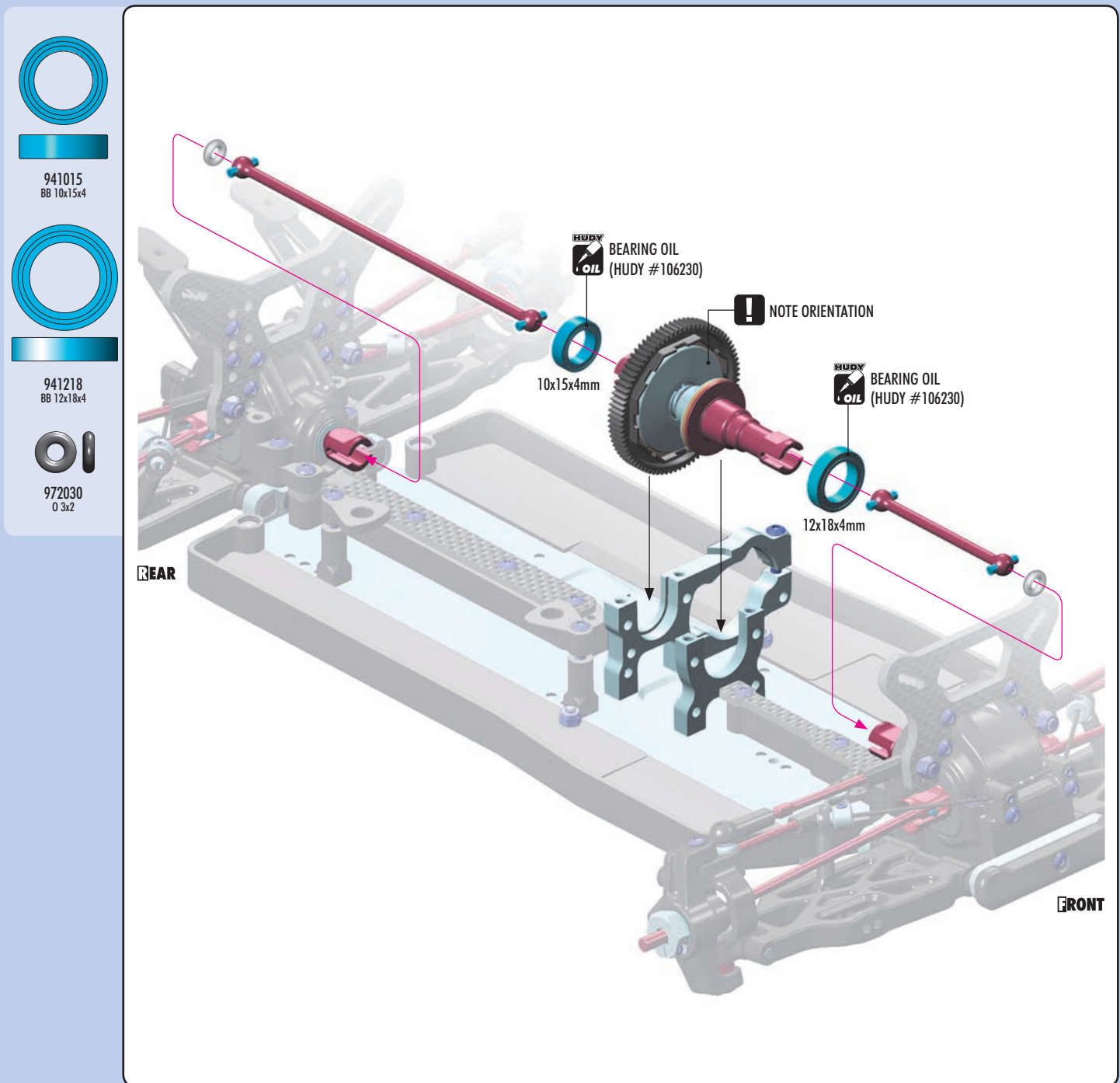
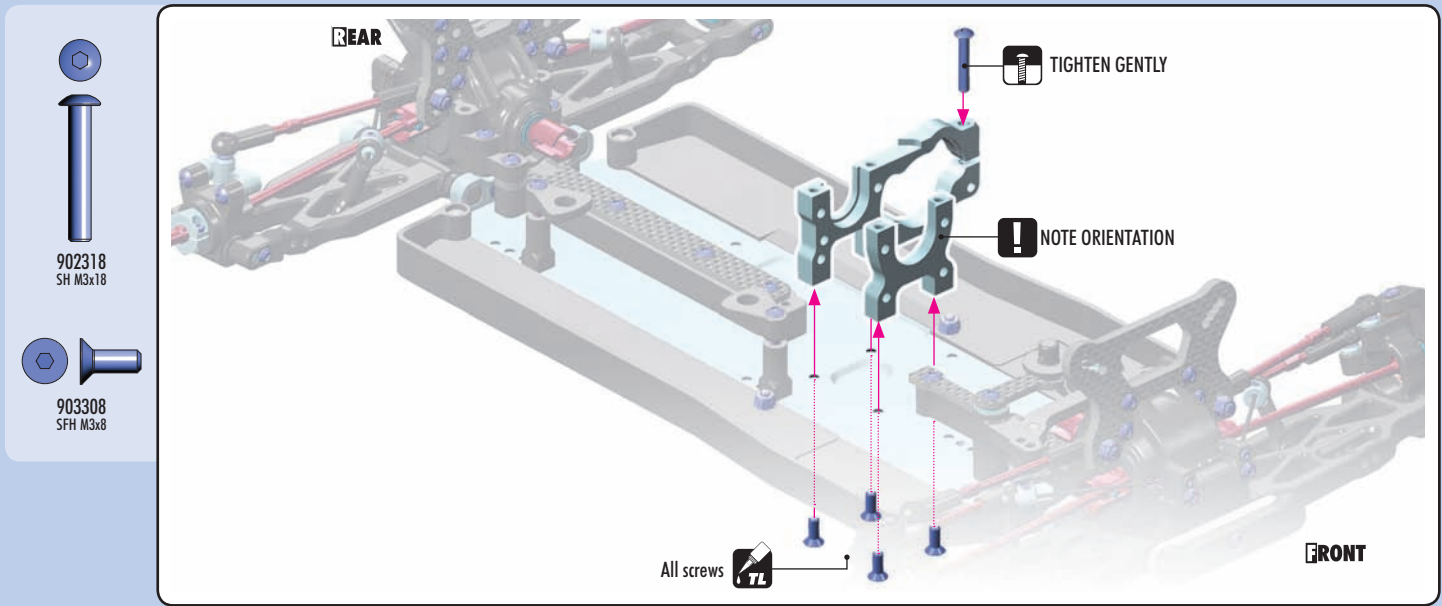

VERY IMPORTANT!
It is very important that you NEVER FULLY TIGHTEN the Slipper Clutch. Overtightening the Slipper Clutch may result in breakage of the diff crown gear and pinion gear.

CENTRAL SLIPPER CLUTCH ADJUSTMENT

The Slipper Clutch can be adjusted by loosening the set-screw and then, while keeping the tool in the set-screw to prevent movement of the collar, rotating the spur gear by hand as indicated in the drawing.

To LOOSEN: Rotate the spur gear in the counterclockwise (CCW) direction.

- Smoother acceleration on power
- Easier to drive

To TIGHTEN: Rotate the spur gear in the clockwise (CW) direction.

- More forward drive
- Less forgiving

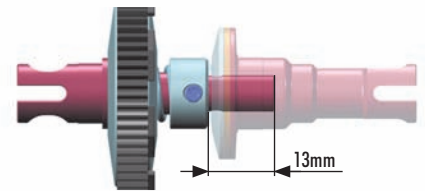

ONE-WAY SLIPPER CLUTCH ADJUSTMENT

For adjusting the front one-way slipper clutch, remove the slipper assembly from car and turn the screw inside the front outdrive using a 2.0mm wrench.

LOOSE - CCW: Greater Rear Brake Bias

- Less weight transfer to front under braking
- Smoother on landings
- Easier to drive

TIGHT - CW: More Aggressive Front Brake Bias

- Less forgiving on landings
- More difficult to drive

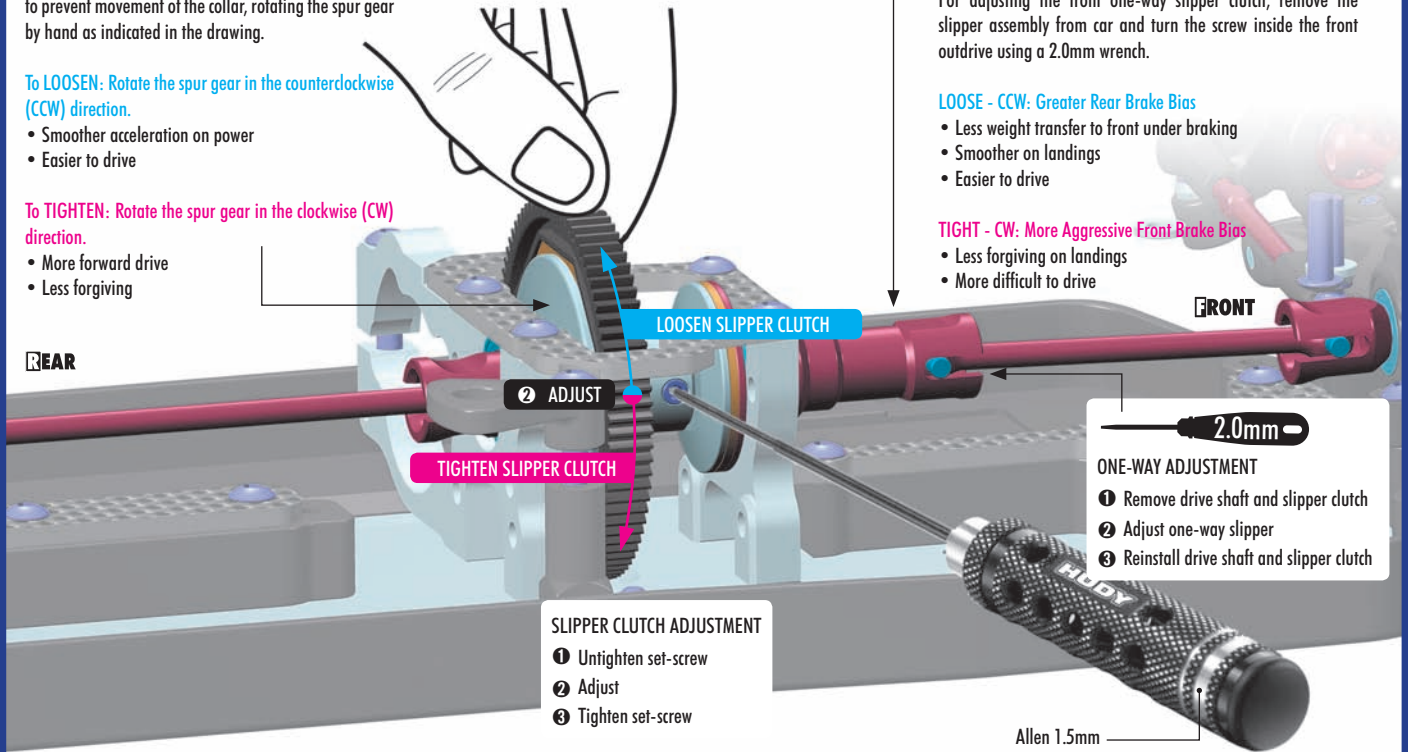

SLIPPER CLUTCH ADJUSTMENT

- 1 Untighten set-screw
- 2 Adjust
- 3 Tighten set-screw

ONE-WAY ADJUSTMENT

- 1 Remove drive shaft and slipper clutch
- 2 Adjust one-way slipper
- 3 Reinstall drive shaft and slipper clutch



902308
SH M3x8

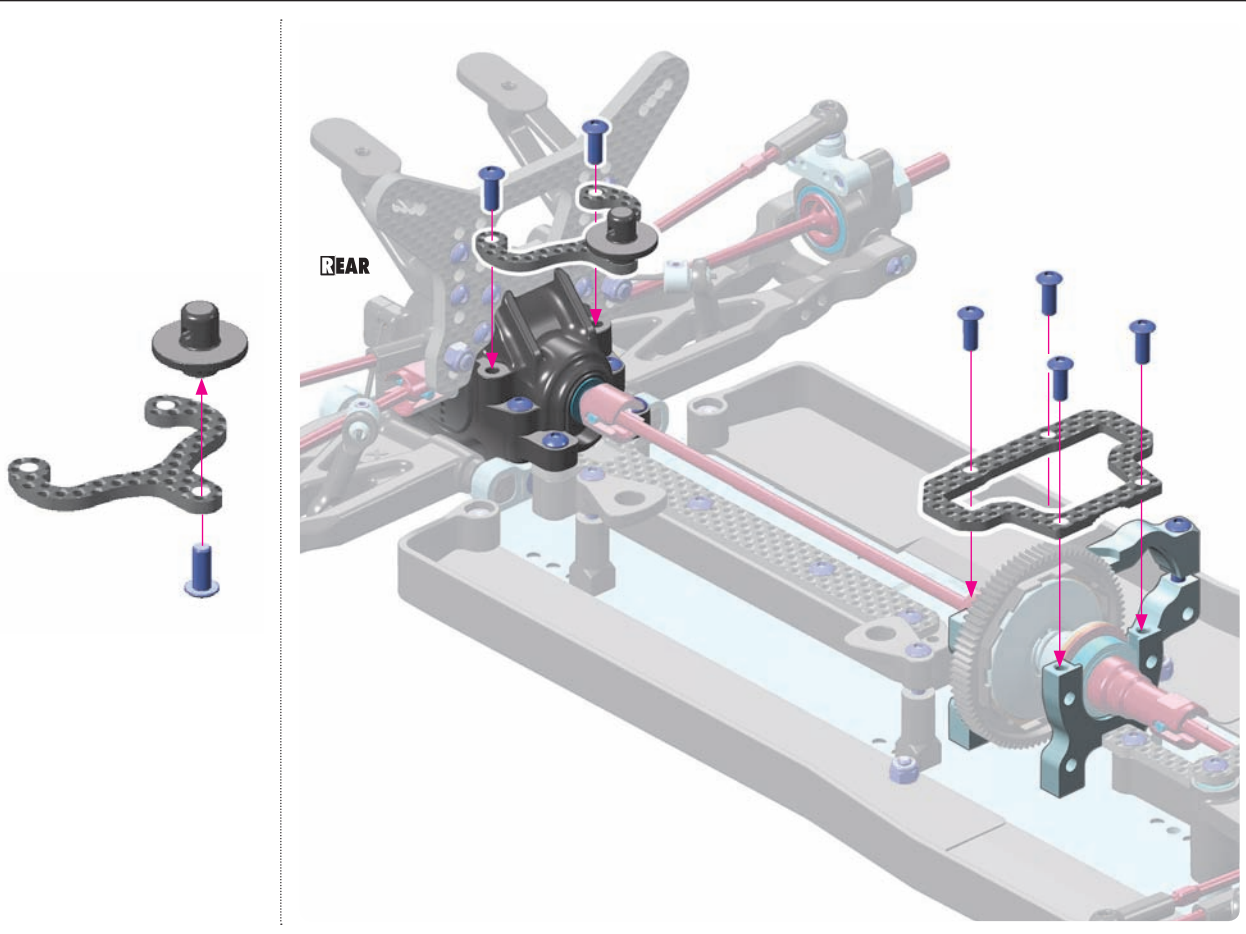

6. CENTER DIFF ASSEMBLY

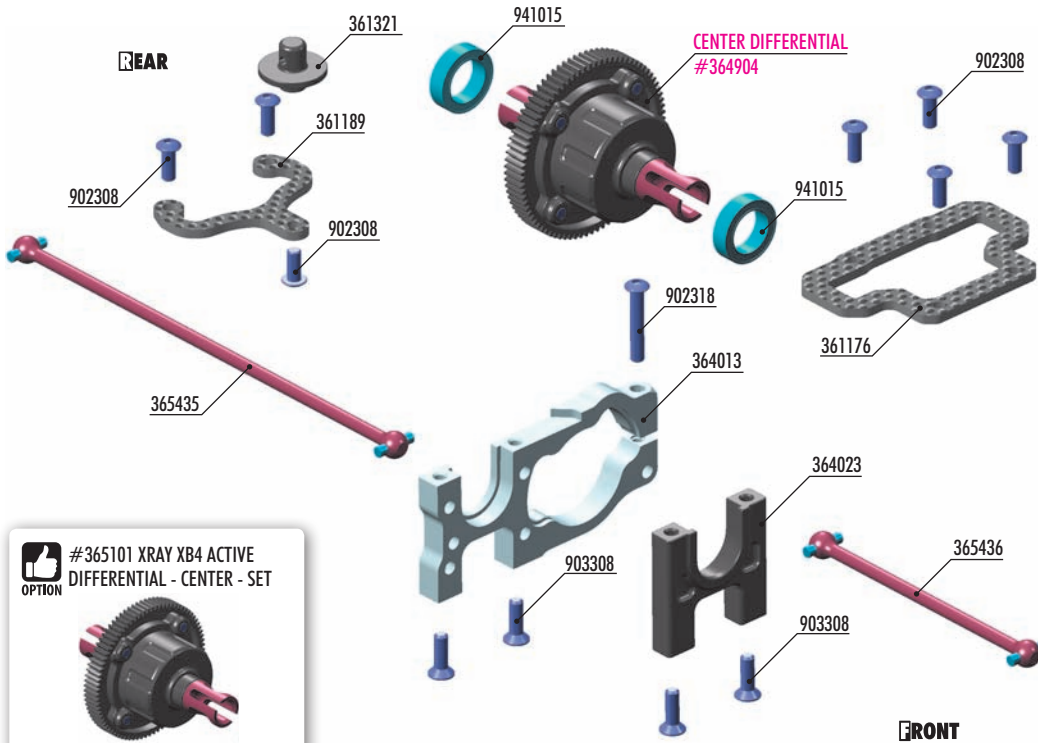

OPTION ONE-WAY SLIPPER CLUTCH CONVERSION

#364101 ONE-WAY SLIPPER CLUTCH SET



#364025 ALU CENTRAL BULKHEAD



#365434 CENTRAL DOGBONE DRIVE SHAFT 47MM



#361159 GRAPHITE CENTER UPPER DECK



OPTION #365101 XRAY XB4 ACTIVE DIFFERENTIAL - CENTER - SET



ACTIVE DIFF SEGMENTS			
#325123	60°		OPTION
#325125	90°		INCLUDED
#325127	120°		OPTION

OPTION #364024 ALU CENTRAL BULKHEAD



BAG 06

- 361176 GRAPHITE CENTER UPPER DECK 2.2MM - V2
- 361189 GRAPHITE REAR BODY POST HOLDER 2.2MM
- 361321 BODY MOUNT - SHORT + SHIMS - SET
- 364013 ALU MOTOR BULKHEAD - LOWER
- 364023 COMPOSITE CENTRAL BULKHEAD - LOWER
- 365435 CENTRAL DOGBONE DRIVE SHAFT 117MM - HUDY SPRING STEEL™

- 365436 CENTRAL DOGBONE DRIVE SHAFT 65MM - HUDY SPRING STEEL™
- 902308 HEX SCREW SH M3x8 (10)
- 902318 HEX SCREW SH M3x18 (10)
- 903308 HEX SCREW SFH M3x8 (10)
- 941015 BALL-BEARING 10x15x4 RUBBER SEALED - OIL (2)

- 902318 SH M3x18
- 903308 SFH M3x8

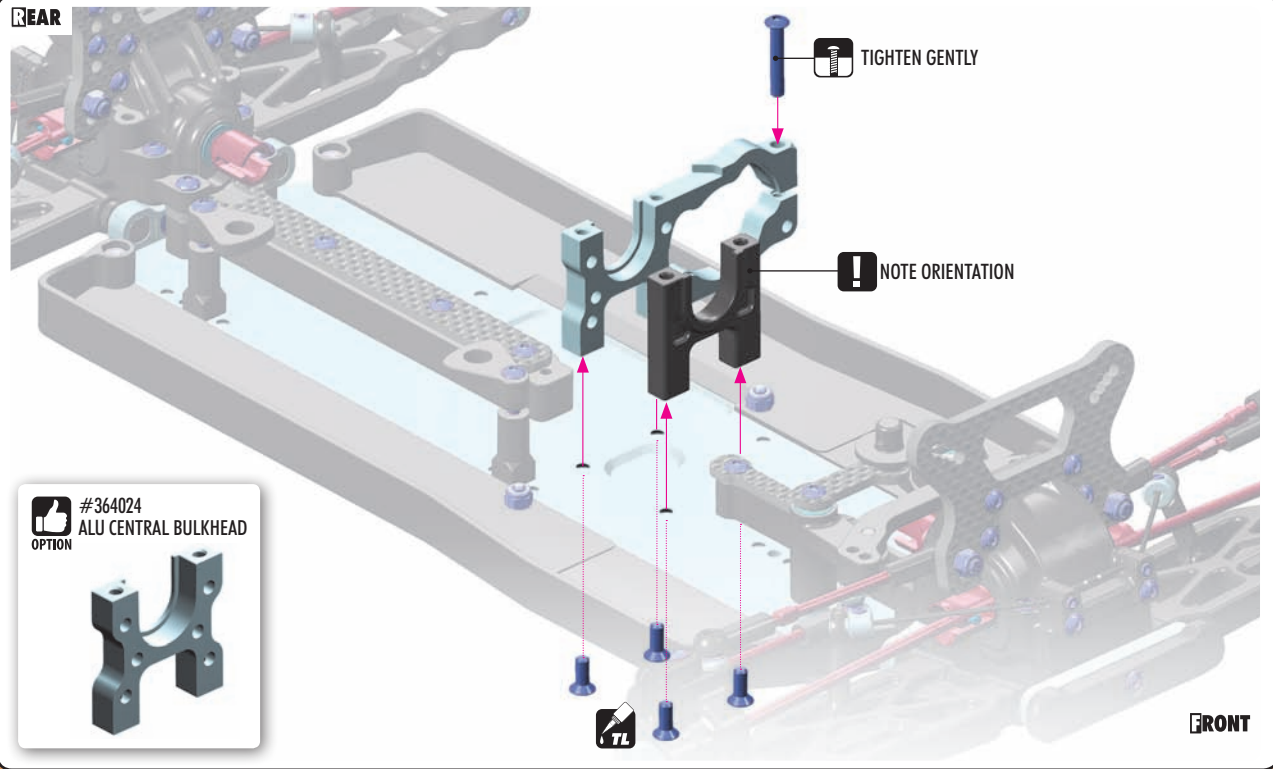

6. CENTER DIFF ASSEMBLY

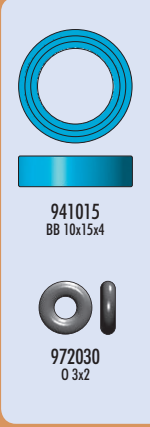

941015
BB 10x15x4

972030
O 3x2

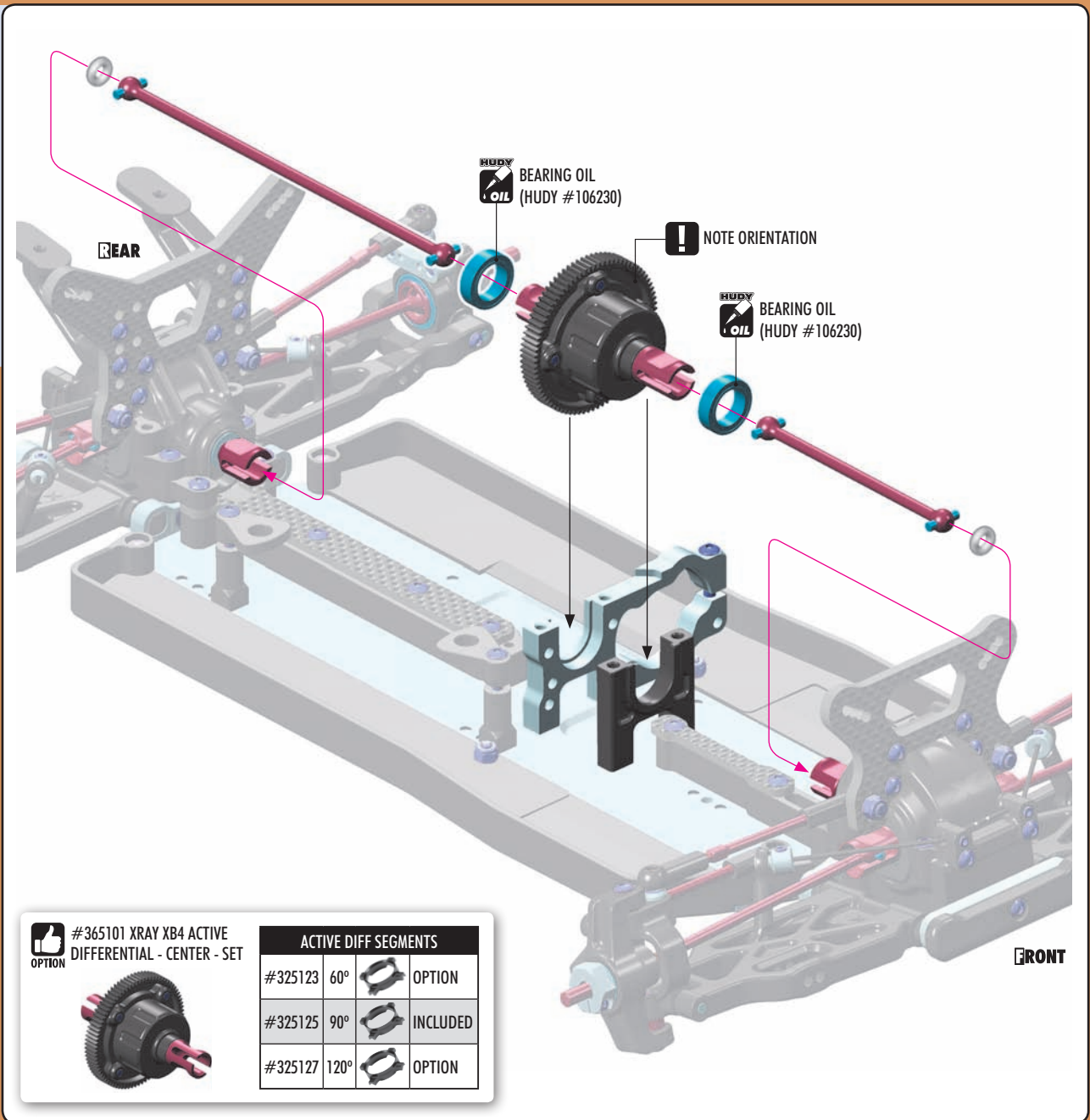

REAR

BEARING OIL (HUDY #106230)

NOTE ORIENTATION

BEARING OIL (HUDY #106230)

FRONT

OPTION #365101 XRAY XB4 ACTIVE DIFFERENTIAL - CENTER - SET

ACTIVE DIFF SEGMENTS			
#325123	60°		OPTION
#325125	90°		INCLUDED
#325127	120°		OPTION



902308
SH M3x8

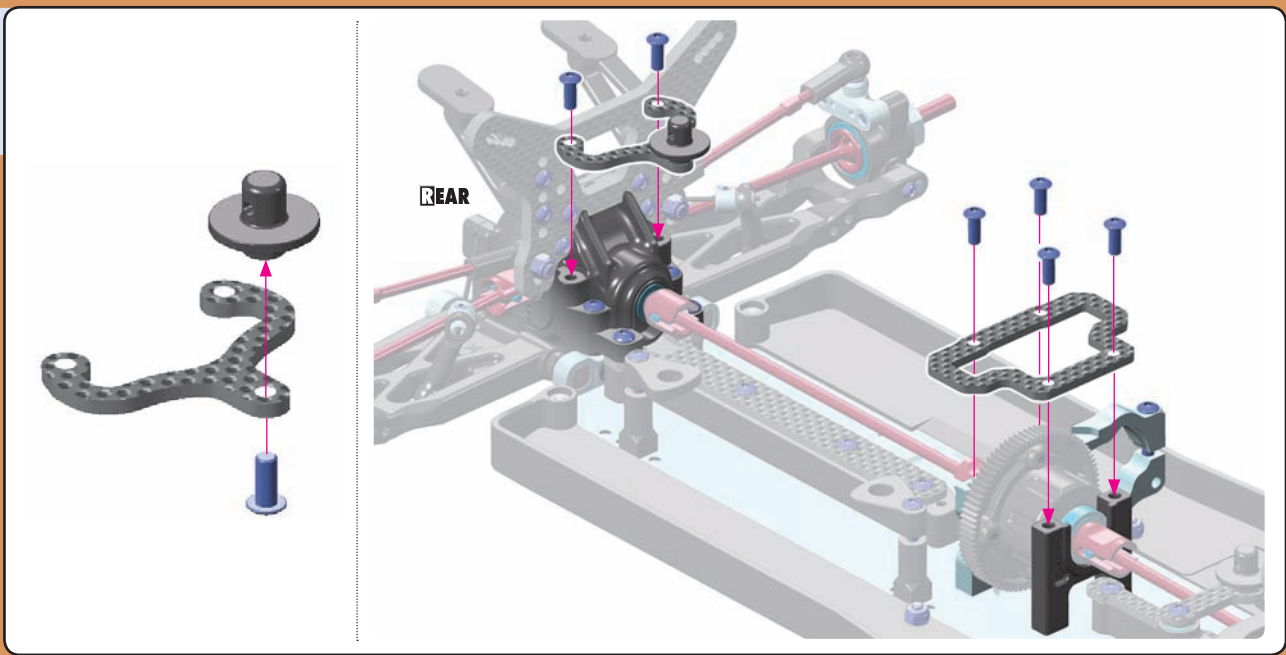

REAR

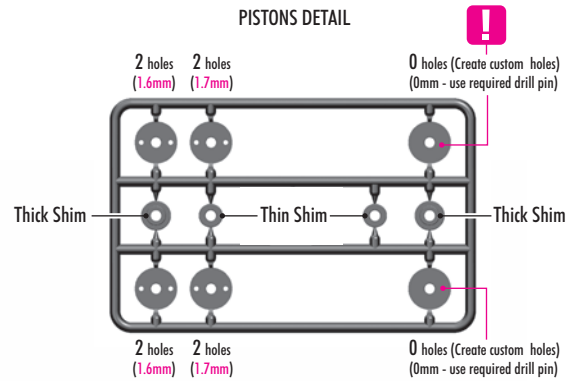
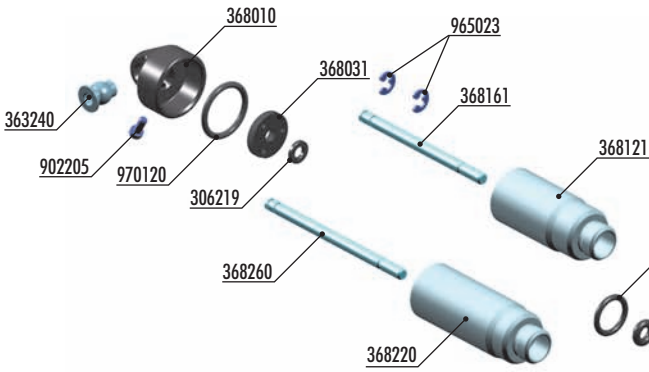

!
These pistons can NOT be used in shocks without making the custom holes by yourselves.

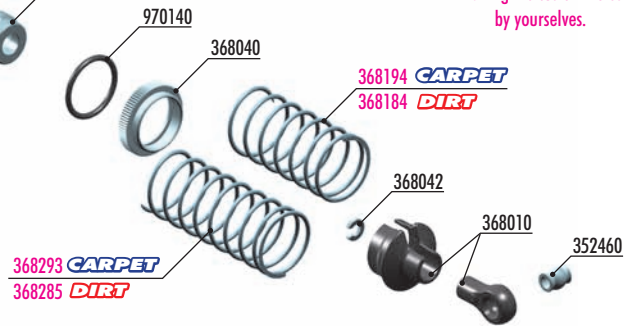

FRONT SPRINGS

OPTION	#368191	LINEAR	42mm	1 DOTS	OPTION
	#368192	LINEAR	42mm	2 DOTS	OPTION
	#368193	LINEAR	42mm	3 DOTS	OPTION
	#368194	LINEAR	42mm	4 DOTS	INCLUDED
	#368195	LINEAR	42mm	5 DOTS	OPTION



REAR SPRINGS

OPTION	#368292	LINEAR	57mm	2 DOTS	OPTION
	#368293	LINEAR	57mm	3 DOTS	INCLUDED
	#368294	LINEAR	57mm	4 DOTS	OPTION



FRONT SPRINGS

OPTION	#368175	PROGRESS.	40mm	3 DOTS	OPTION
	#368182	LINEAR	45mm	1 STRIPE & 3 DOTS	OPTION
	#368183	LINEAR	45mm	1 DOT	OPTION
	#368184	LINEAR	45mm	2 DOTS	INCLUDED
	#368185	LINEAR	45mm	3 DOTS	OPTION
	#368186	LINEAR	45mm	4 DOTS	OPTION



REAR SPRINGS

OPTION	#368273	PROGRESS.	60mm	2 STRIPES	OPTION
	#368275	PROGRESS.	55mm	2 DOTS	OPTION
	#368283	LINEAR	63mm	1 STRIPE & 3 DOTS	OPTION
	#368284	LINEAR	60mm	1 DOT	OPTION
	#368285	LINEAR	60mm	2 DOTS	INCLUDED
	#368286	LINEAR	60mm	3 DOTS	OPTION
	#368287	LINEAR	60mm	4 DOTS	OPTION



#368051
ALU SHOCK CAP-NUT WITH VENT HOLE (2)



#368021
ALU SHOCK SPRING RETAINING COLLAR (4)



#368022
ALU SHOCK SPRING RETAINING COLLAR - 2MM (4)



#104004
HUDY AIR VAC - VACUUM PUMP
- 1/10 OFF-ROAD



BAG



- 306219 COMPOSITE SET OF SERVO SHIMS (4)
- 352460 PIVOT BALL 5.8 - V3 (10)
- 363240 BALL UNIVERSAL 5.8MM WITH BACKSTOP (2)
- 368010 COMPOSITE SHOCK PARTS
- 368031 SHOCK PISTONS - COMPLETE SET - DERLIN - V2
- 368040 ALU SHOCK ADJUSTABLE NUT (2)
- 368042 COMPOSITE SHOCK BUSHING & SHIM FOR ALU CAP (2+2)
- 368121 ALU FRONT SHOCK BODY 32MM - V2 (2)
- 368140 ALU LOWER SHOCK BODY CAP (2)
- 368161 FRONT HARDENED SHOCK SHAFT 42MM (2)
- 368200 REAR SHOCK ABSORBERS COMPLETE SET (2)
- 368220 ALU REAR SHOCK BODY (2)
- 368260 REAR HARDENED SHOCK SHAFT (2)

- 902205 HEX SCREW SH M2x5 (10)
- 965023 E-CLIP 2.3 (10)
- 970080 O-RING 8x1 (10)
- 970120 O-RING 12 x 1.0 (10)
- 970140 O-RING 14 x 1.5 (10)
- 972031 SILICONE O-RING 3x2.1 (10)

- 368184 FRONT SPRING SET L=45MM - 2 DOTS (2)
- 368194 FRONT SPRING SET L=42MM - 4 DOTS (2)
- 368285 REAR SPRING SET L=60MM - 2 DOTS (2)
- 368293 REAR SPRING SET L=57MM - 3 DOTS (2)

7. SHOCK ABSORBERS

CARPET DIRT

965023
C 2.3

970080
O 8x1

972031
O 3x2.1

SET-UP BOOK
SHOCK DAMPING
SHOCK PISTONS

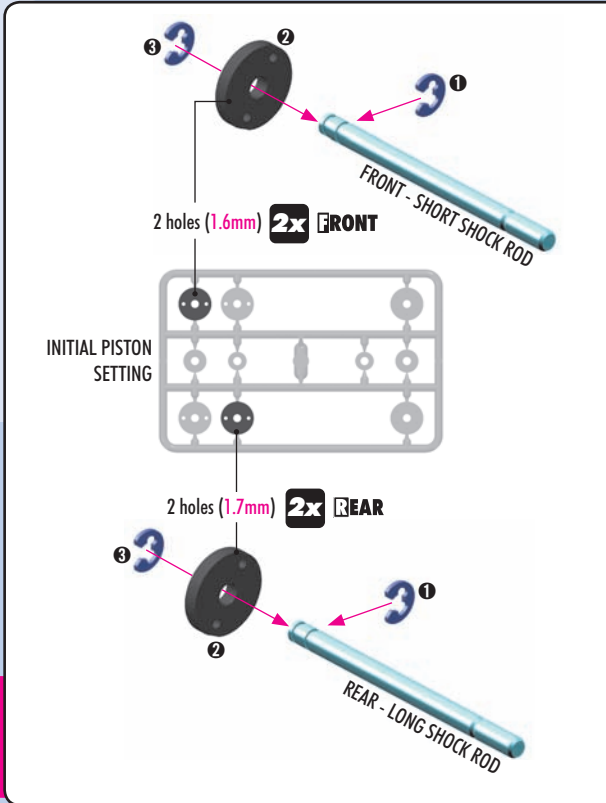

4x

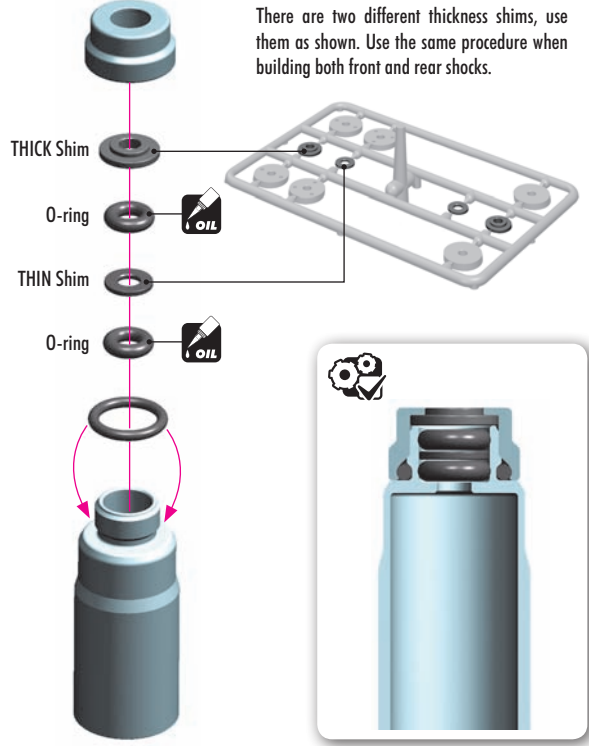

IO
306219
SHIM 3x6x2

#306219
DOWNSTOP SHIMS
THICKER shim used, GREATER downstop is achieved.

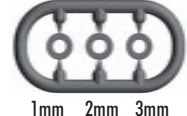

! IMPORTANT
Always use same shim thickness on right and left side to achieve same downstop.

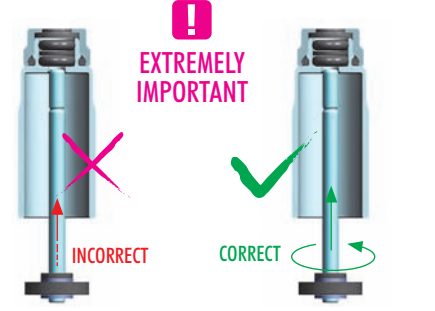
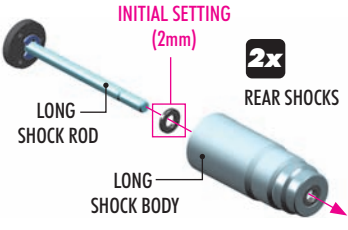
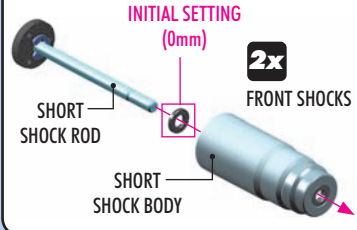

Do not push the shock rod straight through the lower shock body assembly; O-ring damage may result.

Twist the shock rod through the lower shock body assembly.

970140
O 14x1.5

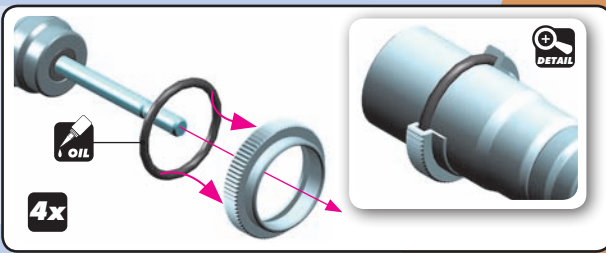

970120
O 12x1

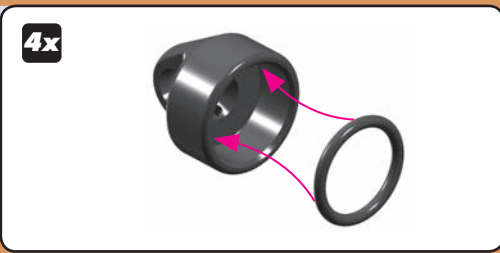

UP-STOP "C" SHIMS

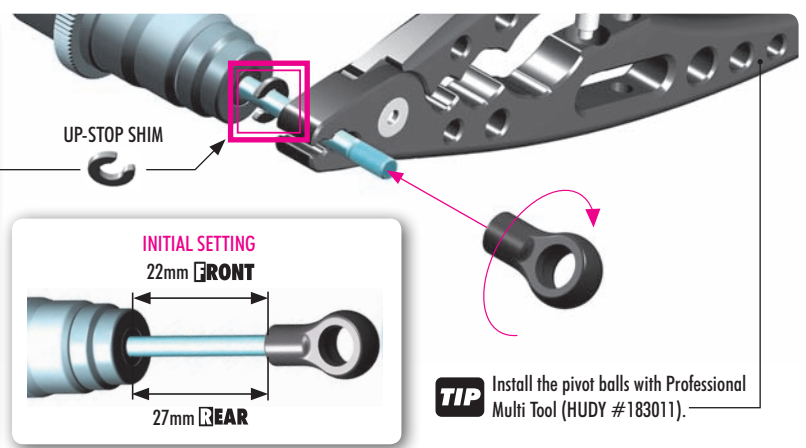
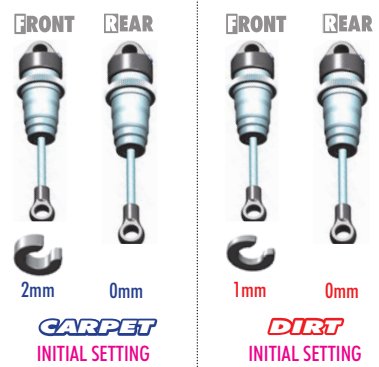

IMPORTANT

UP-STOP TRAVEL SETTINGS

It is very important to have properly set the up-stop travel to avoid damage to the drive shaft and diff outdrives.

To avoid collision of the drive shaft with diff outdrives use the up-stop travel shims to set-up the up-stop travel.

All these settings have influence on the up-stop travel:

- Length of arms (long/short)
- Length of drive shafts
- Shock positions
- Eccentric bushings in suspension holders
- Eccentric bushings in rear uprights
- Camber

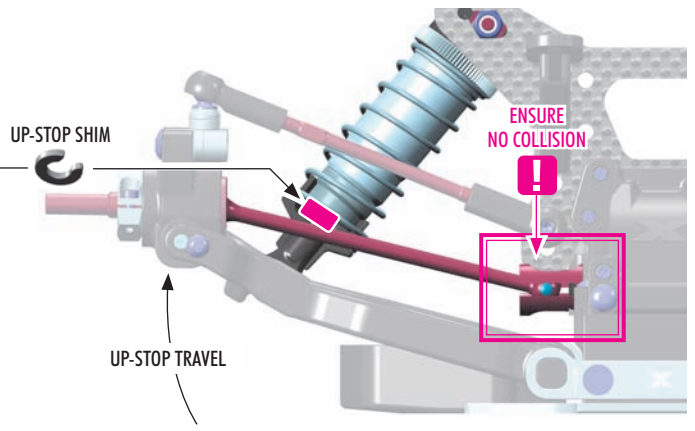

- | | |
|---------------|---------------|
| CARPET | DIRT |
| FRONT (SHORT) | FRONT (SHORT) |
| Oil 700cSt | Oil 600cSt |
| REAR (LONG) | REAR (LONG) |
| Oil 550cSt | Oil 500cSt |

DEFAULT SHOCK REBOUND SETTING 0% REBOUND

- Extend the shock shaft completely. Fill the shock body with the shock oil. For the FRONT shocks use 700cSt or 600cSt oil. For the REAR shocks use 550cSt or 500cSt oil.
- Move the shock shaft up and down a few times to release the air bubbles trapped beneath the piston.
- Orient the filled shock vertically for several minutes with the shock shaft fully extended. The remaining air bubbles will release.
- Gently place the shock cap onto the filled shock body and start to tighten the cap. Tighten the cap fully.
- Gently push the shock shaft completely into the shock body. Excess oil will flow through the hole in the shock cap.
- Keep the shock shaft pushed in the shock body and insert the screw into the shock cap. Tighten gently.
- 6x push the shaft up and down.
- Untighten the screw.
- Gently push the shock shaft completely into the shock body. Excess oil will flow through the hole in the shock cap.
- Tighten the screw. The rebound will be at approx. 0%.

<p>SHORT FRONT SHOCKS Short Springs</p> <p>2x</p>	<p>LONG REAR SHOCKS Long Springs</p> <p>2x</p>
---	--

FOR EXTREMELY LOW RIDE HEIGHT
OPTIONAL #368022 MUST BE USED

#368022
ALU SHOCK SPRING RETAINING COLLAR -2MM (4)

<p>2x FRONT SHOCKS (SHORT)</p>	<p>2x REAR SHOCKS (LONG)</p>
--------------------------------	------------------------------

#363242
PIVOT BALL ECCENTRIC (2)

* Fits only REAR shock absorbers

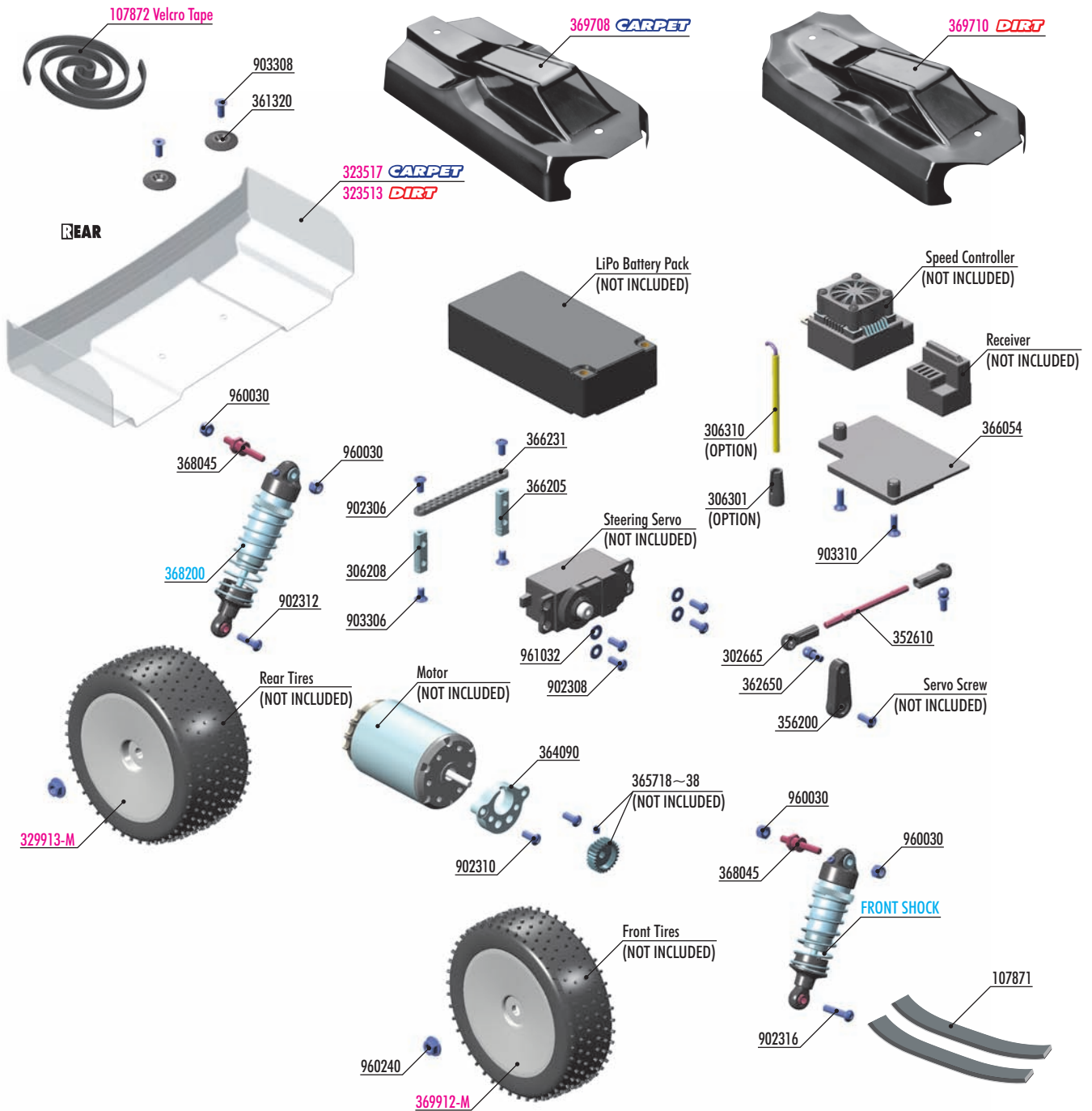

BAG

08

- | | | | |
|-----------|---|----------|--|
| 107871 | HUDY SELF-ADHESIVE FOAM STRIP (2) | 903306 | HEX SCREW SFH M3x6 (10) |
| 302665 | COMPOSITE BALL JOINT 4.9MM - CLOSED WITH HOLE (4) | 903308 | HEX SCREW SFH M3x8 (10) |
| 306208 | ALU SERVO MOUNT 21MM - BOTH SIDES THREADED | 903310 | HEX SCREW SFH M3x10 (10) |
| 306301 | ANTENNA MOUNT - THIN (OPTION) | 960030 | NUT M3 (10) |
| 306310 | ANTENNA (2) (OPTION) | 961032 | WASHER S 3.2 (10) |
| 352610 | ADJ. TURNBUCKLE M3 L/R 45 MM - SPRING STEEL™ (2) | 960240 | NUT M4 WITH SERRATED FLANGE (10) |
| 352610 | ADJ. TURNBUCKLE M3 L/R 45 MM - SPRING STEEL™ (2) | 368200 | REAR SHOCK ABSORBERS COMPLETE SET (2) |
| 356200 | BRAKE/THROTTLE ARMS & STEERING SERVO ARMS - SET | 107872 | VELCRO TAPE WITH DOUBLE SIDED TAPE 8x500MM |
| 361320 | BODY MOUNT, BATTERY MOUNT - V2 & WING SHIM (2) | 323513 | LEXAN REAR WING - RANK |
| 362650 | BALL END 4.9MM WITH THREAD 6MM (2) | 323517 | LEXAN REAR WING - TEC |
| 364090 | ALU ECCENTRIC MOTOR BULKHEAD INSERT - V3 | 329913-M | REAR WHEEL AERODISK WITH 12MM HEX IFMAR - WHITE (2) |
| 365718~38 | ALU PINION GEAR HARD COATED 18~38T/48 (OPTION) | 369708 | BODY FOR 1/10 4WD OFF-ROAD BUGGY - GAMMA 4C |
| 366054 | COMPOSITE RADIO PLATE - SHORT | 369710 | BODY FOR 1/10 4WD OFF-ROAD BUGGY - GAMMA 4D |
| 366205 | ALU SERVO MOUNT 22MM - BOTH SIDES THREADED | 369912-M | FRONT WHEEL AERODISK WITH 12MM HEX IFMAR - WHITE (2) |
| 366231 | GRAPHITE SERVO HOLDER 2.2MM | | |
| 368045 | STEEL SCREW SHOCK PIVOT BALL WITH HEX (2) | | |
| 902306 | HEX SCREW SH M3x6 (10) | | |
| 902308 | HEX SCREW SH M3x8 (10) | | |
| 902310 | HEX SCREW SH M3x10 (10) | | |
| 902312 | HEX SCREW SH M3x12 (10) | | |
| 902316 | HEX SCREW SH M3x16 (10) | | |



902316
SH M3x16



960030
N M3

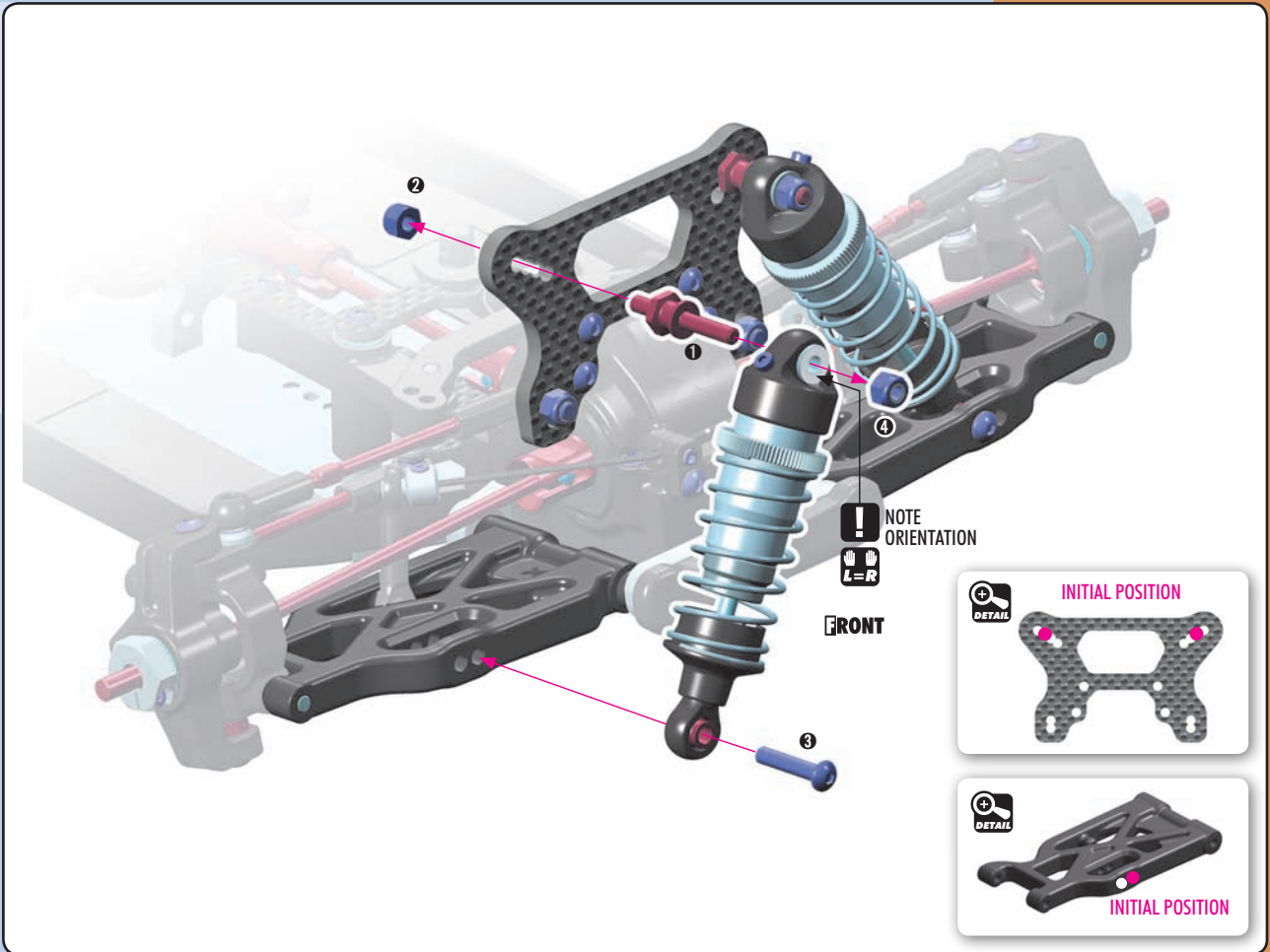

902312
SH M3x12



960030
N M3

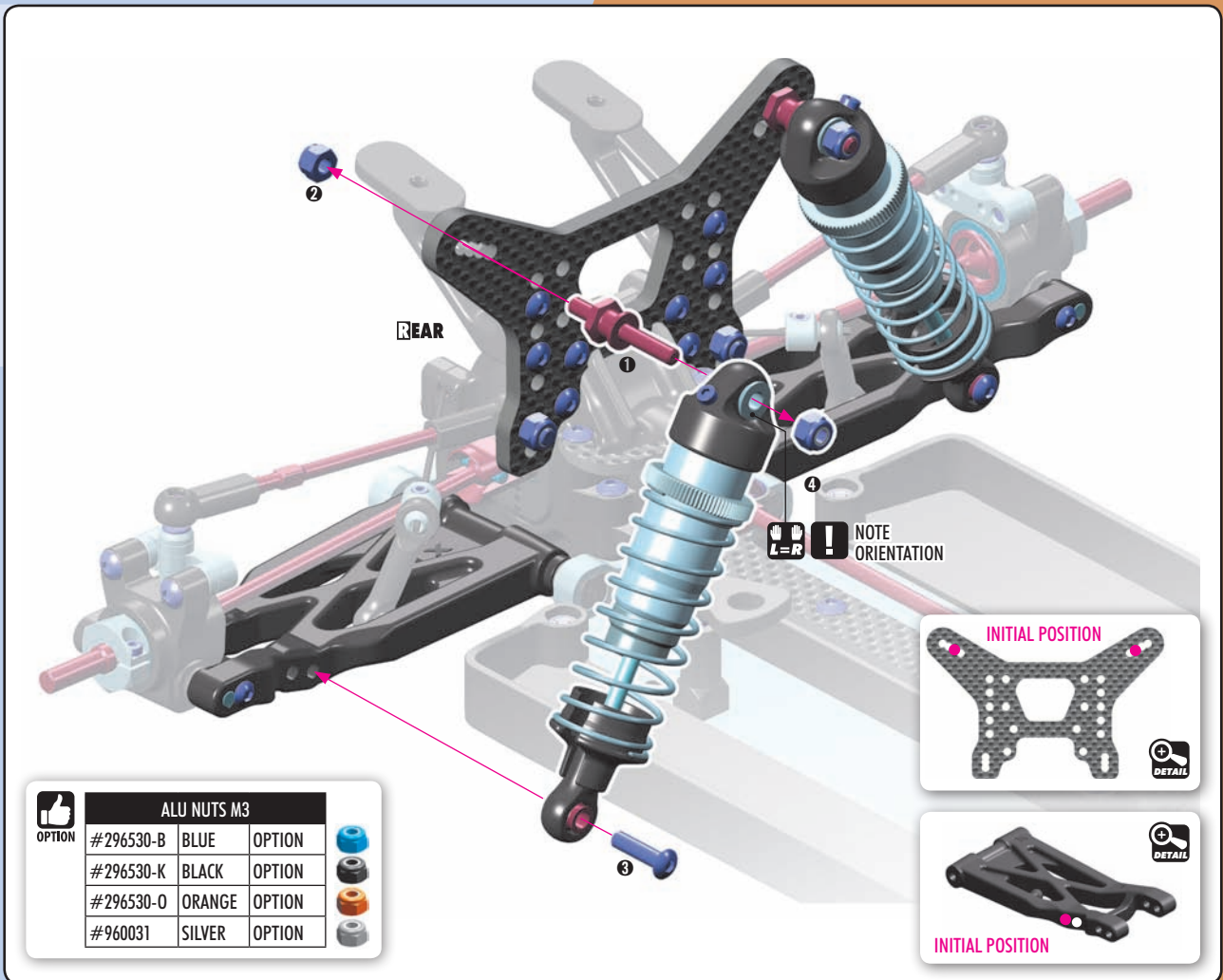

ALU NUTS M3			
OPTION	#296530-B	BLUE	OPTION
	#296530-K	BLACK	OPTION
	#296530-O	ORANGE	OPTION
	#960031	SILVER	OPTION



SERVO LINK
Adjust servo link to fit your servo.

TIP Install the pivot balls with Professional Multi Tool (HUDY #183011).

INITIAL SETTING
CARPET DIRT

- 902306 SH M3x6
- 902308 SH M3x8
- 961032 SHIM S 3.2

NOTE ORIENTATION

Servo (NOT INCLUDED)

3x6mm

3x8mm

Servo screw (NOT INCLUDED)

NOTE ORIENTATION

HUDY ALU SERVO HORNS	
#293497	23T
#293498	24T
#293499	25T

HUDY CLAMP ALU SERVO HORNS	
#293404	23T
#293405	24T
#293406	25T

For more in-corner steering and better steering response, aluminum servo horns may be used.

USE APPROPRIATE SERVO ARM:

K (23T) **H** (24T) **F** (25T)

- 903306 SFH M3x6

FRONT



902310
SH M3x10

Motor (NOT INCLUDED)

NOTE ORIENTATION

NOTE ORIENTATION

Pinion (NOT INCLUDED)
OPTION

PINIONS	
#365718	18T / 48P
#305919	19T / 48P
#294020	20T / 48P
#294021	21T / 48P
#294022	22T / 48P
#294023	23T / 48P
#305924	24T / 48P
#365725	25T / 48P
#365726	26T / 48P
#365727	27T / 48P
#365728	28T / 48P
#365729	29T / 48P
#365730	30T / 48P
#365731	31T / 48P
#365732	32T / 48P
#365733	33T / 48P
#365734	34T / 48P
#365735	35T / 48P
#365736	36T / 48P
#365737	37T / 48P
#365738	38T / 48P

- Loosen the screw.
- Insert motor into the bulkhead.

1 Adjust gear mesh.
2 Tighten the screw.

CORRECT

INCORRECT

Adjust the motor so the pinion meshes with the spur gear properly. Make sure the gear mesh is not too tight.

There should be a small amount of play between the teeth of the pinion gear and the spur gear.

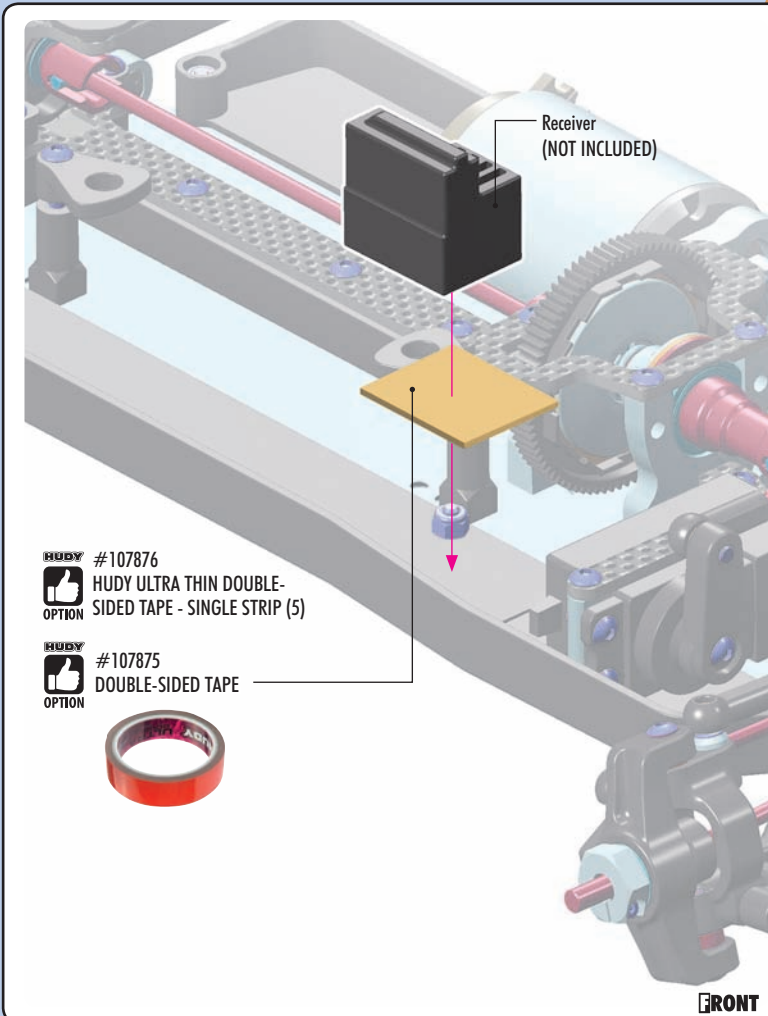
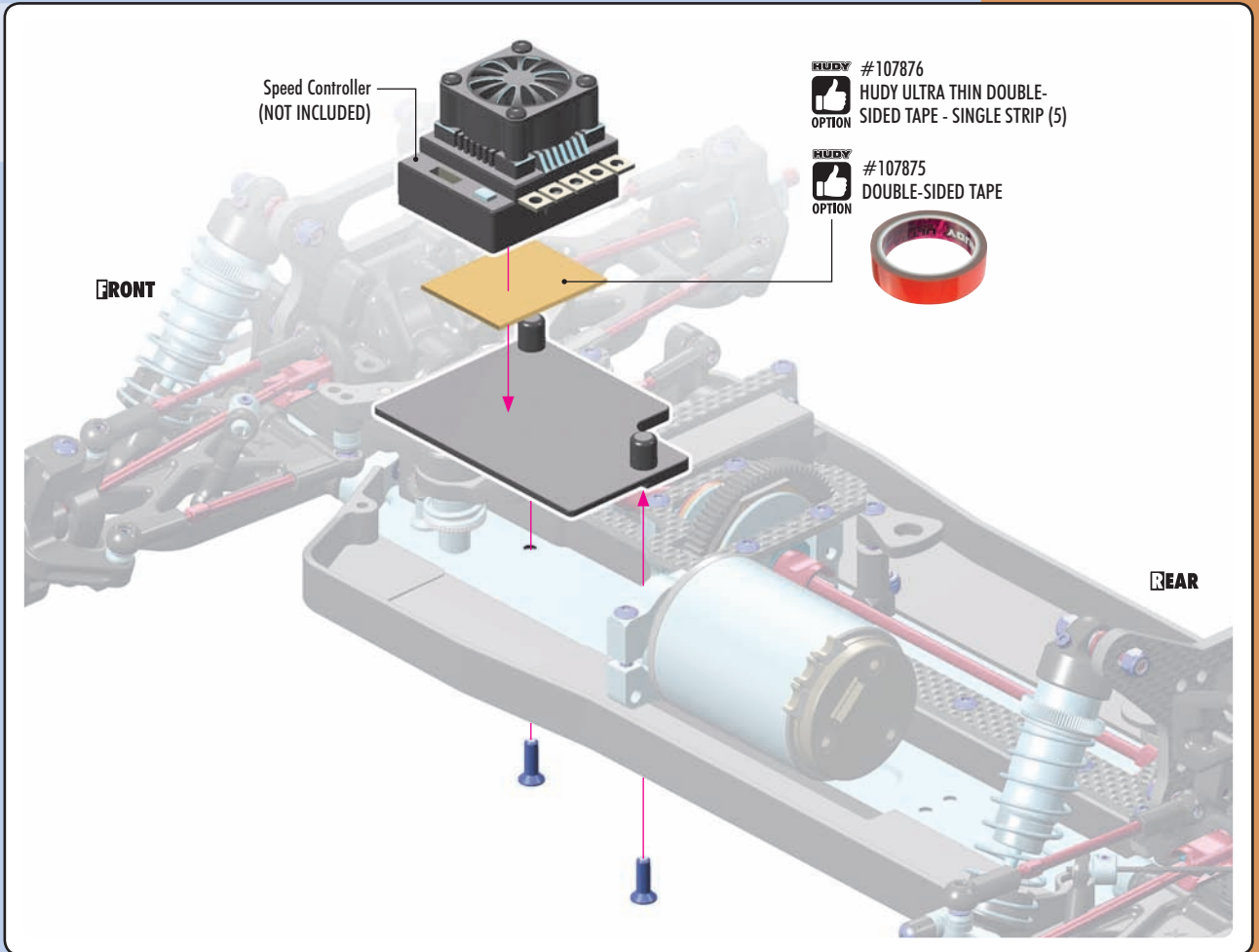
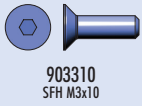

ANTENNA ALTERNATIVE (OPTION)

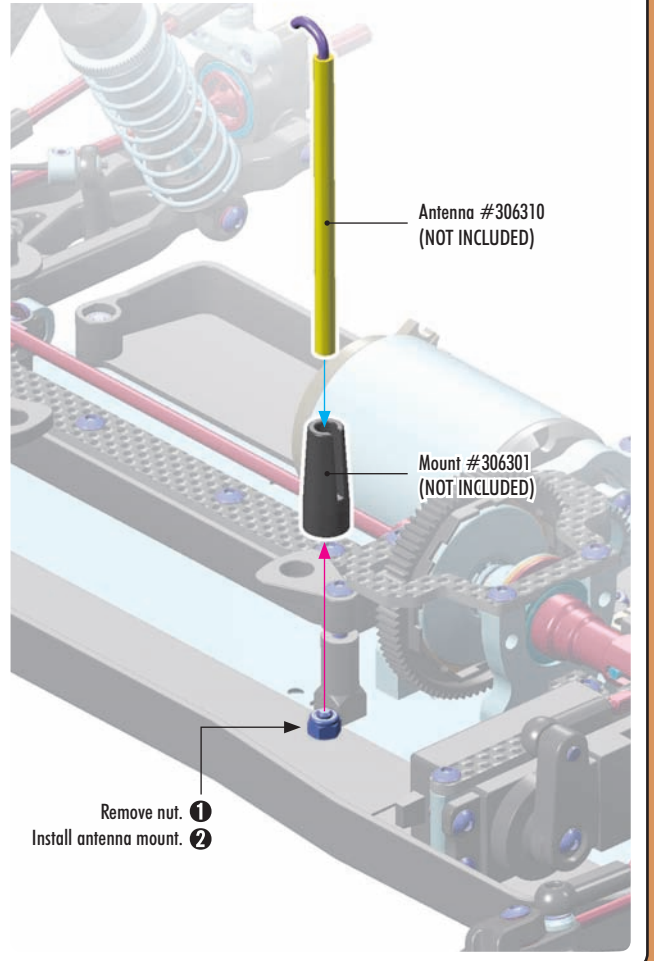

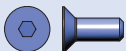
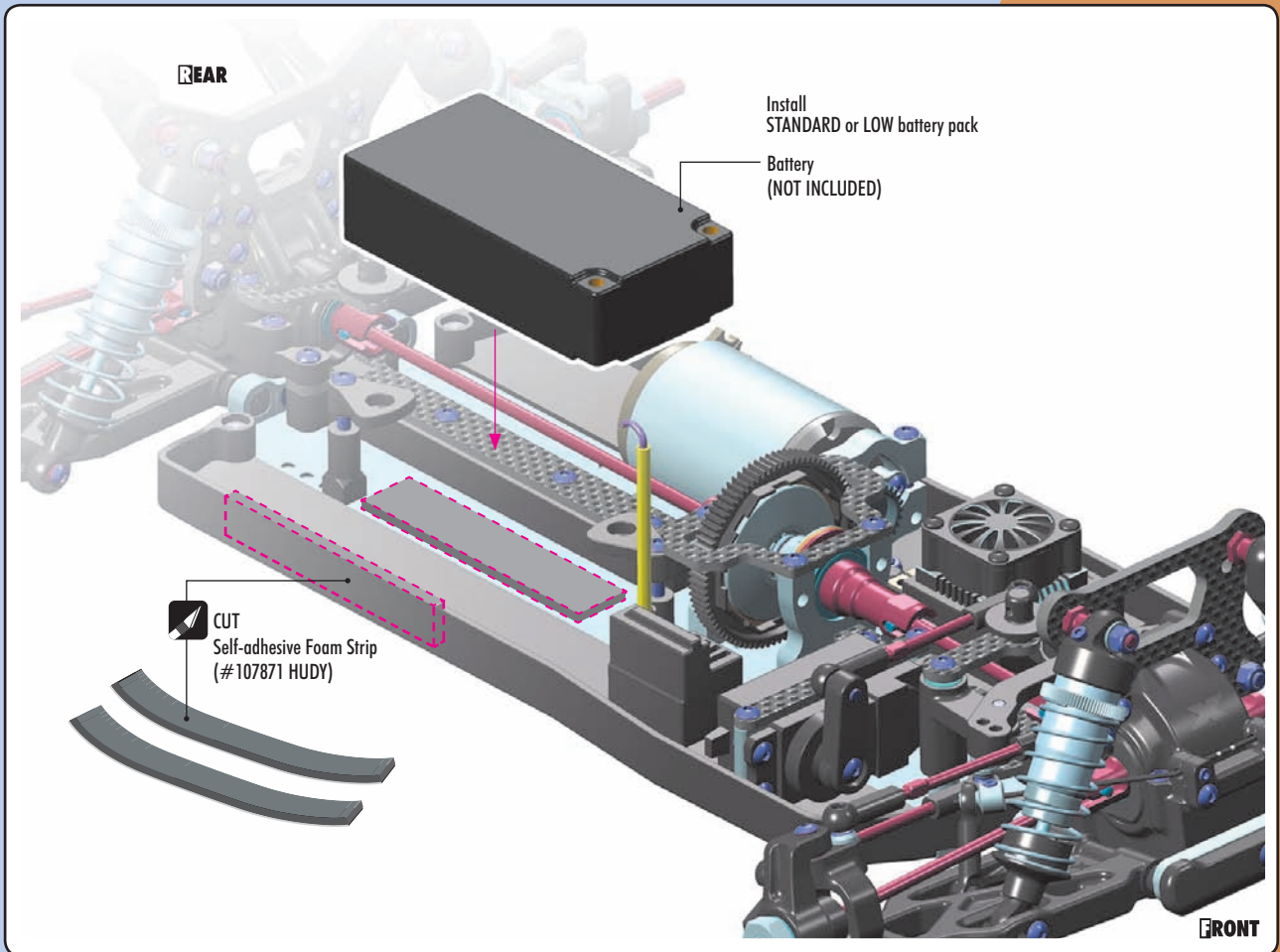

903308
SFH M3x8

WING CUTTING LINE OPTIONS

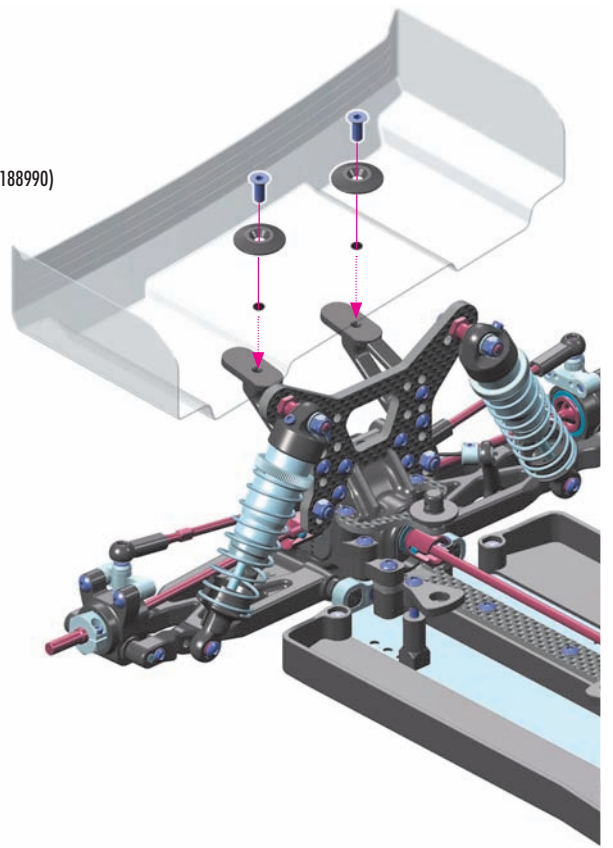
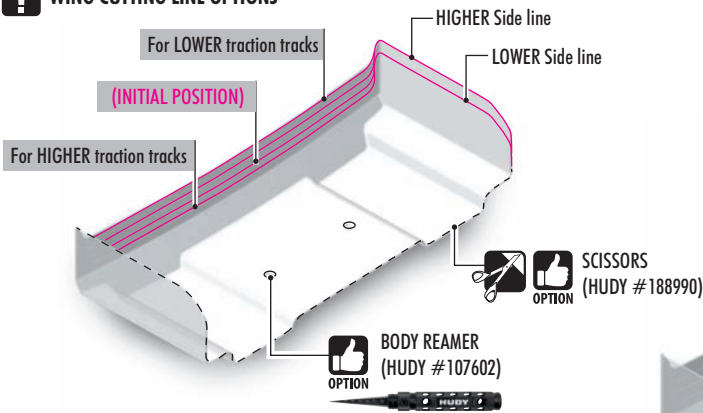

OPTION	REAR WING SHIM		
#293561	SILVER	OPTION	
#293561-O	ORANGE	OPTION	
#293561-K	BLACK	OPTION	

OPTION	XRAY LEXAN REAR WING		
#323510	1.0mm	OPTION	
#323511	1.5mm	OPTION	
#323513	1.0mm	RANK INCLUDED	DIRT
#323517	1.0mm	TEC INCLUDED	CARPET
#363510	1.0mm	OPTION	
#363511	1.5mm	OPTION	
#363512	2.0mm	OPTION	

XRAY LEXAN CENTER FIN		
#323515	1.0mm	ZAP OPTION

- 1 Before cutting and making holes on the BODY, put the unpainted body on the chassis to confirm the mounting position and location for holes and cutouts. Before cutting and making holes on the WING, put the unpainted wing on the wing holders to confirm the mounting position and location for holes and cutouts.
- 2 Before painting, wash the inside of the body with mild detergent, and then rinse and dry thoroughly.
- 3 Mask all windows.

- 4 Apply paint masks as appropriate.
- 5 Paint the body using paints formulated for polycarbonate bodies.
- 6 When the paint is dry, remove the masking.
- 7 Carefully cut out the body using appropriate scissors or cutting tools.
- 8 When you have finished cutting, peel off the external protective films.

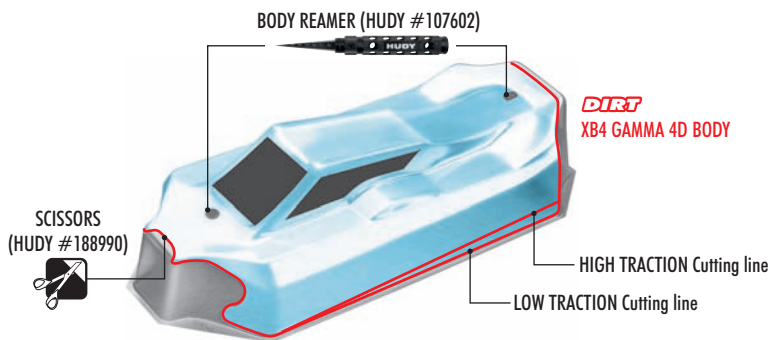
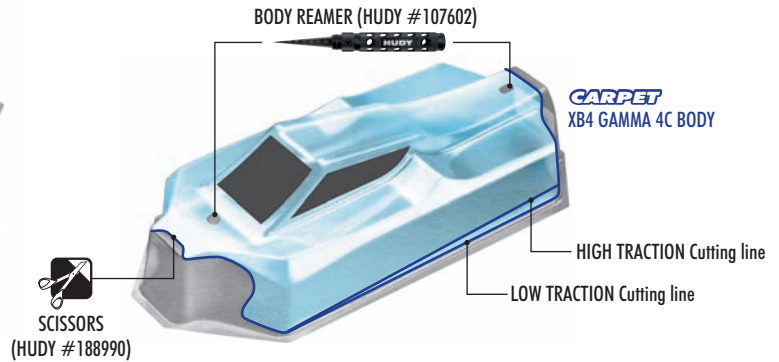
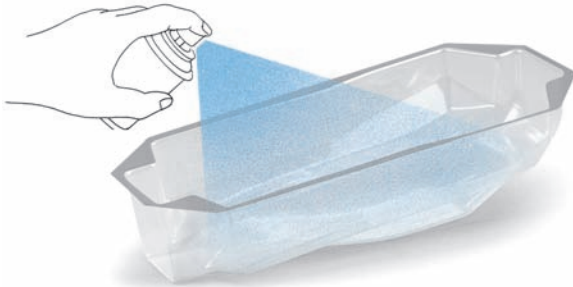

XRAY LEXAN BODY				
OPTION	#369708	0.75mm	GAMMA 4C	INCLUDED
	#369709	0.50mm	GAMMA 4CL	OPTION
	#369710	0.75mm	GAMMA 4D	INCLUDED
	#369711	0.50mm	GAMMA 4DL	OPTION

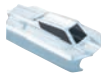

2x L=R

Double-sided Velcro™ tape is used to seal the body against the side guards.

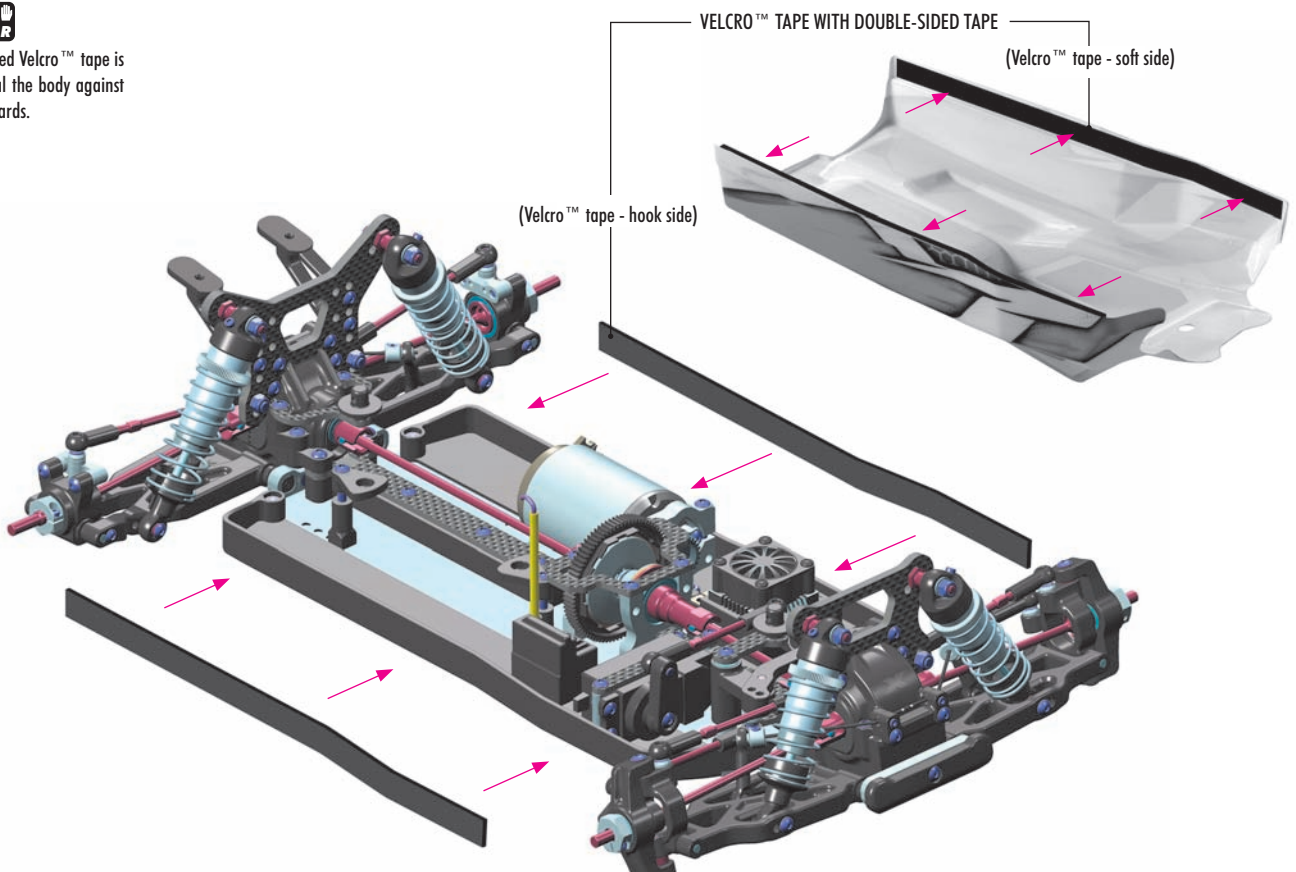

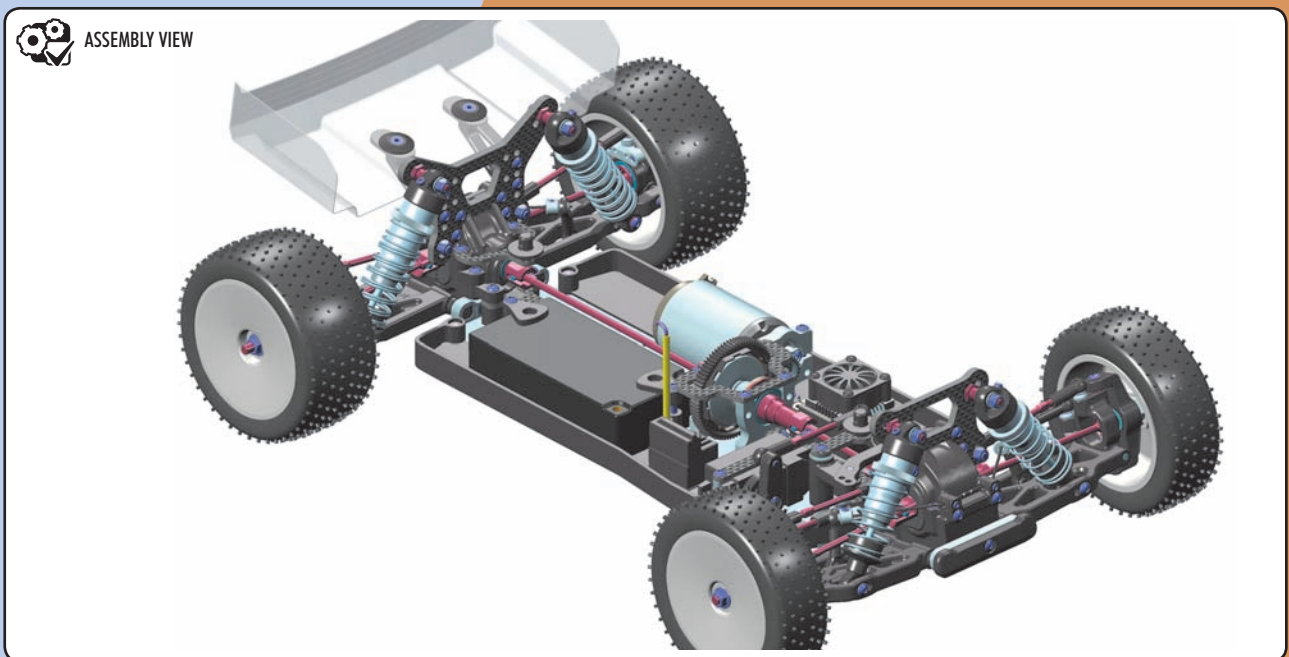
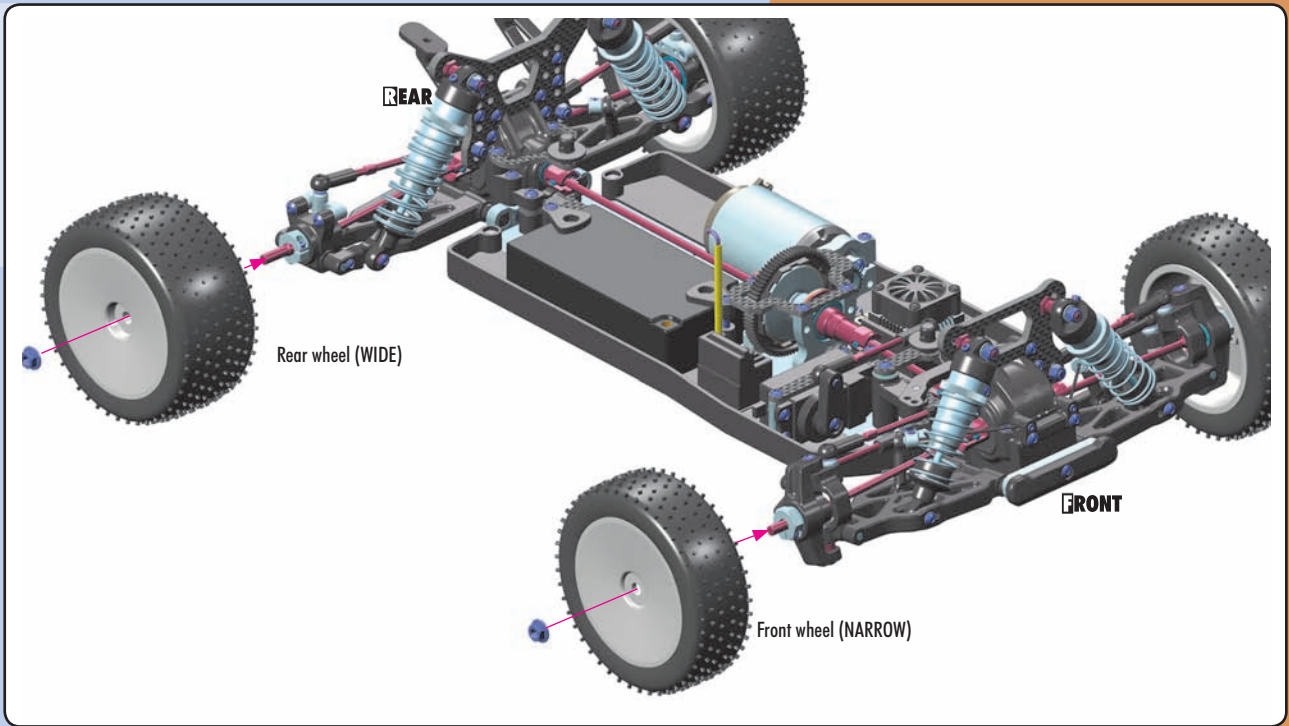
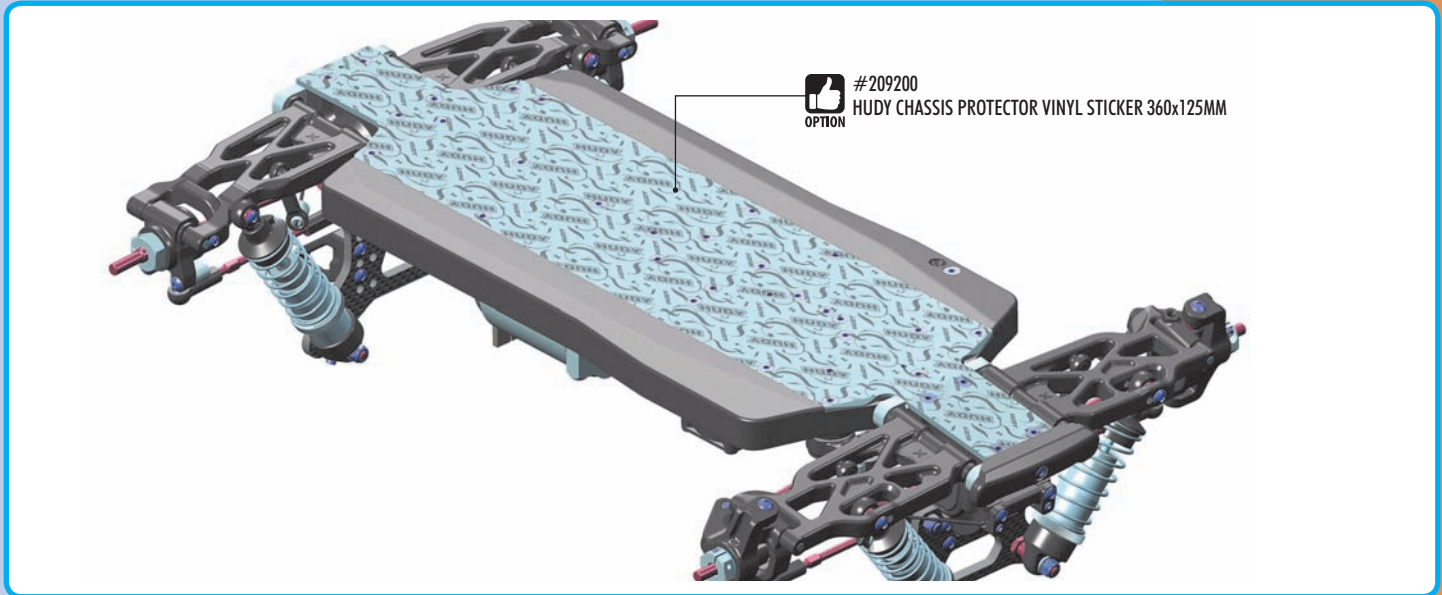

SHOCK MAINTENANCE

The most important maintenance task for keeping consistent shock performance is refilling and bleeding them correctly. If built correctly, it will not be necessary to re-build them often. Replacing warped/hard o-rings, scarred piston rods, or shaved/split/loose composite upper and lower ball joints are also important.

- For club racing, it is recommended to check the shocks for air inside before each race and only re-fill and bleed them if necessary. Before each race day, make sure you take the spring off of each shock, hold it up to your ear, and quickly compress the shock rod fully into the body while listening for any air making a "whistling" or "squishy" sound as it passes through the piston holes. If you hear any air, refill and bleed your shocks. For high-competition racing, it is recommended that the shocks be re-filled and bled before a large event.
- If building or pairing new shocks, always make sure they are the same length using a shock length measuring tool and adjust the lower ball joints as needed.
- During regular shock operation, oil naturally gets on the shock shaft and drop-by-drop slightly gets out of the shock body. Shocks should be inspected regularly after each race, and oil replaced as required.

BEARING MAINTENANCE

Ball-bearings in an off-road car must be properly maintained for smooth operation and long lifespan.

The ball-bearings are degreased and are lubricated with HUDY Bearing Oil or HUDY Grease. The following procedures are recommended to clean all of the bearings in your off-road car. For high-competition racing, we recommended doing this every 3-4 weeks, or before a major race.

- 1 Remove the seals on both sides of the bearing (if present). If the seals bend a little and you can see a kink, carefully flatten the kink out by hand.
- 2 Spray the seals with motor cleaner and blow dry with compressed air.
- 3 Spray the bearing on both sides with motor cleaner.
- 4 Spin the bearing while it is still wet to dislodge any particles with the cleaner.
- 5 Spray the bearing on both sides again.
- 6 Blow both sides of the bearing dry with compressed air to make sure particles come out.
- 7 Hold the inner part of the bearing with my left thumb/forefinger and spin it to make sure it spins free without any abnormal vibrations or sounds.
- 8 Place one drop of bearing oil into each side of the bearing.
- 9 Replace both seals at the same time by lining them up on each side of the bearing and lightly pressing them in all the way around the bearings circumference with your thumb and forefinger. Do not press too hard or use any type of tool, such as a wrench tip, to push the blue seals in as they will push in too far, bend and cause drag.

If you spin test the bearing after you have re-oiled and sealed it, it will not spin freely for an extended period of time. The lightest of oils may allow it to spin for 1-2 seconds. This is normal and once you have mounted the bearings in the car again, the drive train will spin freely.

Make sure you use a motor cleaner that does not leave a residue after it dries as this may cause drag and wear in the bearings.

RECOMMENDED PRODUCTS

- Use correct oil or grease to lubricate the bearings:
 #106230 HUDY Bearing Oil
 #106220 HUDY Bearing Grease - Standard
 #106221 HUDY Bearing Grease - Blue
 #106222 HUDY Bearing Grease - Red



SUSPENSION & DRIVETRAIN MAINTENANCE

- Check suspension for free movement during building and operation, and especially after running and if you have crashed the car. If the suspension does not move freely, use the appropriate HUDY Arm Reamer to clean and resize the holes of the suspension arms.
- Regularly check the drive shaft pins (both side and center) and if they show any wear must be immediately replaced by new pins. If the car is run with worn pins, excessive wear on the diff outdrives will result. The #106000 HUDY Drive Pin Replacement Tool (for 3mm Pins) is a compact, rugged multi-use tool set for replacing 3mm drive pins in drive shafts. Use the HUDY replacement drive shaft pins 3x12 (#106051).
- Regularly inspect and replace the connecting pins which connect the center drive shafts with the pinion gear, and also the pins that connect the wheel drive shafts with wheel axles. Use HUDY Graphite Grease to lubricate the drive shaft connecting joints and the diff gears.
- Pivot balls and ball-joints will naturally wear for some time and will generate play. If there is too much play the pivot balls and ball joints need to be replaced.
- If the car is run in wet conditions, apply WD-40® on all drivetrain parts before the run. After the run, clean and dry the parts again.



#106210 HUDY GRAPHITE GREASE or #106213 HUDY JOINT GREASE

HUDY SPRING STEEL™

The HUDY Spring Steel™ used in the car is the strongest and most durable steel material on the RC market. While items made from HUDY Spring Steel™ are still subject to wear, the lifespan is considerably longer than any other material. As parts made from HUDY Spring Steel™ wear, the

brown color will fade (get lighter) but it will not affect the strength of the material. The brown color is only a surface treatment and if the brown color will wear the durability of the part will be still strong.

RACE

TRACK

NAME DATE

LAPS BEST LAP TIME sec

QUALIFYING POSITION FINAL POSITION

TRACK

SIZE OPEN MEDIUM TIGHT

TRACTION

VERY-LOW MEDIUM VERY-HIGH

SURFACE SMOOTH MEDIUM BUMPY

TYPE CLAY CARPET ASTRO

CONDITION BLUE GROOVE HARD PACKED DRY

DUSTY LOAMY WET

DIFFERENTIAL TYPE

FRONT ↓	MIDDLE ↓	REAR ↓
GEAR DIFF <input type="checkbox"/>	GEAR DIFF <input type="checkbox"/>	GEAR DIFF <input type="checkbox"/>
BALL DIFF <input type="checkbox"/>	SLIPPER <input type="checkbox"/>	BALL DIFF <input type="checkbox"/>
ACTIVE DIFF <input type="checkbox"/>	ACTIVE DIFF <input type="checkbox"/>	ACTIVE DIFF <input type="checkbox"/>
60° 90° 120°	60° 90° 120°	60° 90° 120°
OIL <input type="text"/> cst	OIL <input type="text"/> cst	OIL <input type="text"/> cst

SATELLITE GEARS

FRONT	MIDDLE	REAR
COMPOSITE <input type="checkbox"/>	COMPOSITE <input type="checkbox"/>	COMPOSITE <input type="checkbox"/>
STEEL <input type="checkbox"/>	STEEL <input type="checkbox"/>	STEEL <input type="checkbox"/>
40T <input type="checkbox"/> 41T	CROWN GEAR	40T <input type="checkbox"/> 41T

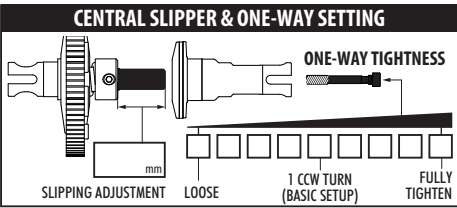

GEARING

PINION T CENTER DIFF SPUR

FRONT	SHOCKS	REAR
cst	SPRINGS	cst
%	OIL	%
<input type="checkbox"/> 2 HOLES <input type="checkbox"/>	PISTONS	<input type="checkbox"/> 2 HOLES <input type="checkbox"/>
<input type="checkbox"/> 3 HOLES <input type="checkbox"/>	ø1.2mm <input type="checkbox"/>	<input type="checkbox"/> 3 HOLES <input type="checkbox"/>
<input type="checkbox"/> 6 HOLES <input type="checkbox"/>	ø1.3mm <input type="checkbox"/>	<input type="checkbox"/> 6 HOLES <input type="checkbox"/>
<input type="checkbox"/> HOLES <input type="checkbox"/>	ø1.4mm <input type="checkbox"/>	<input type="checkbox"/> HOLES <input type="checkbox"/>
	ø1.6mm <input type="checkbox"/>	
	ø1.7mm <input type="checkbox"/>	
	CUSTOM PISTONS	
	ø mm <input type="text"/> ø mm <input type="text"/>	

ANTI ROLL BAR

FRONT THICKNESS REAR

FRONT	TIRES	REAR
	BRAND	
	COMPOUND	
	INSERTS	
	WHEELS	

ELECTRONICS

MOTOR SPEEDO

MOTOR TIMING BATTERY

BATTERY SIZE

STD. SHORT LOW SHORT

BODY

TYPE STANDARD LIGHT

COMMENTS

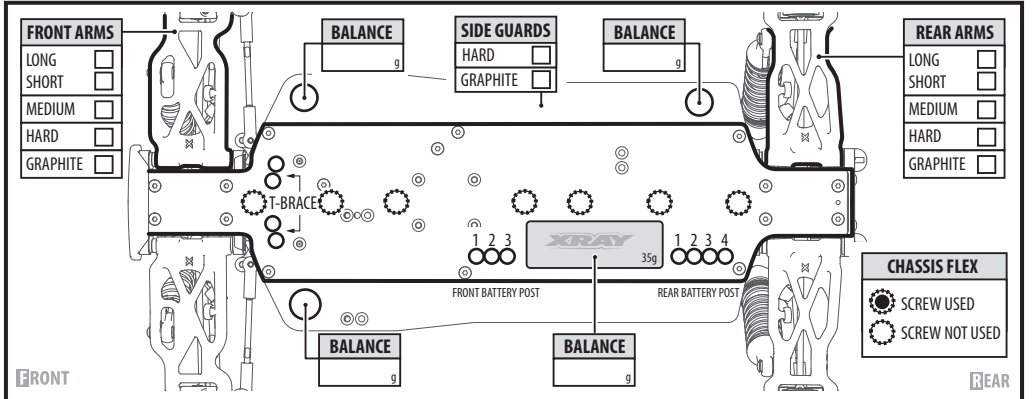
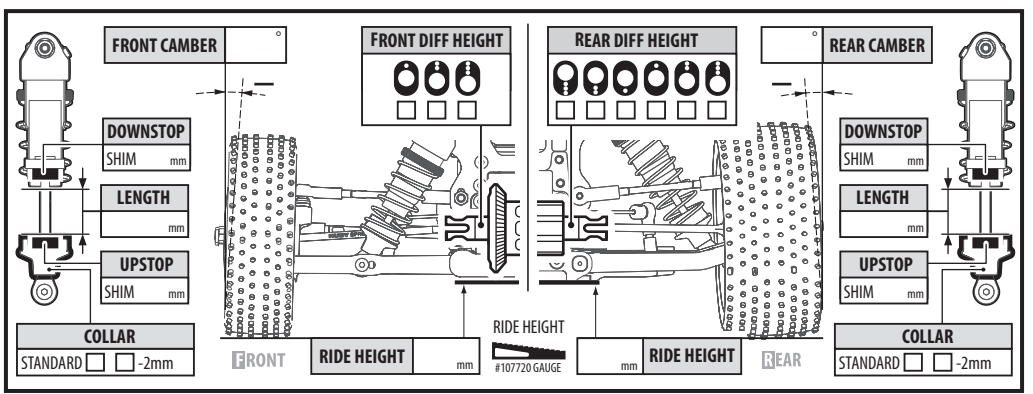
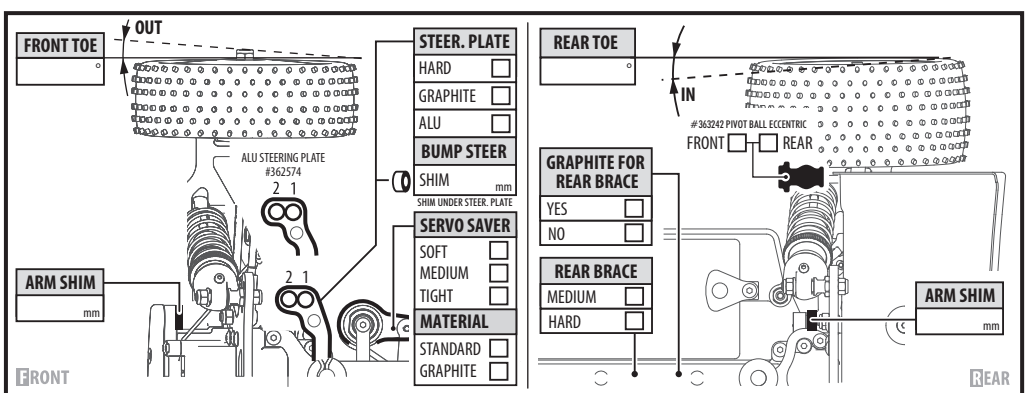
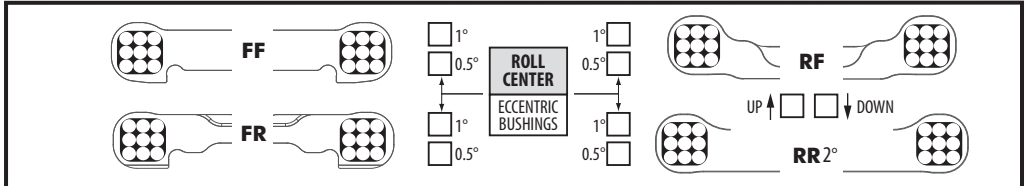
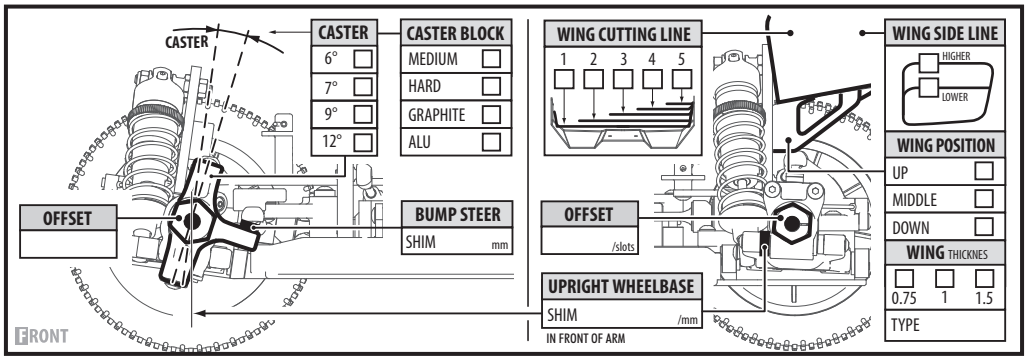
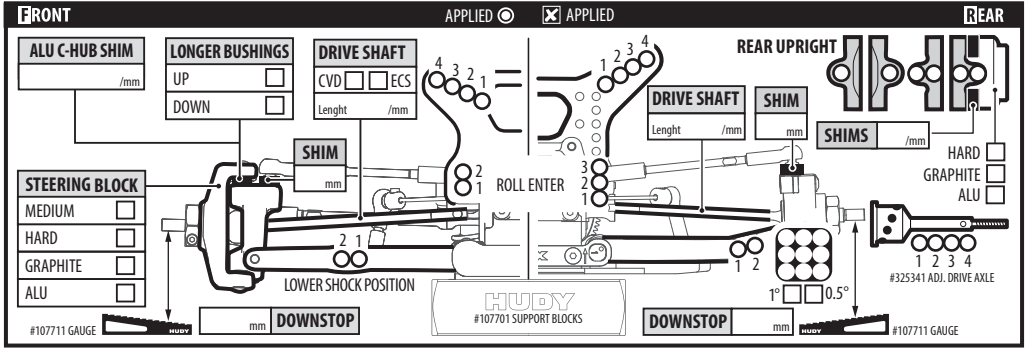

EXCLUSIVE PROFESSIONAL

HUDY®

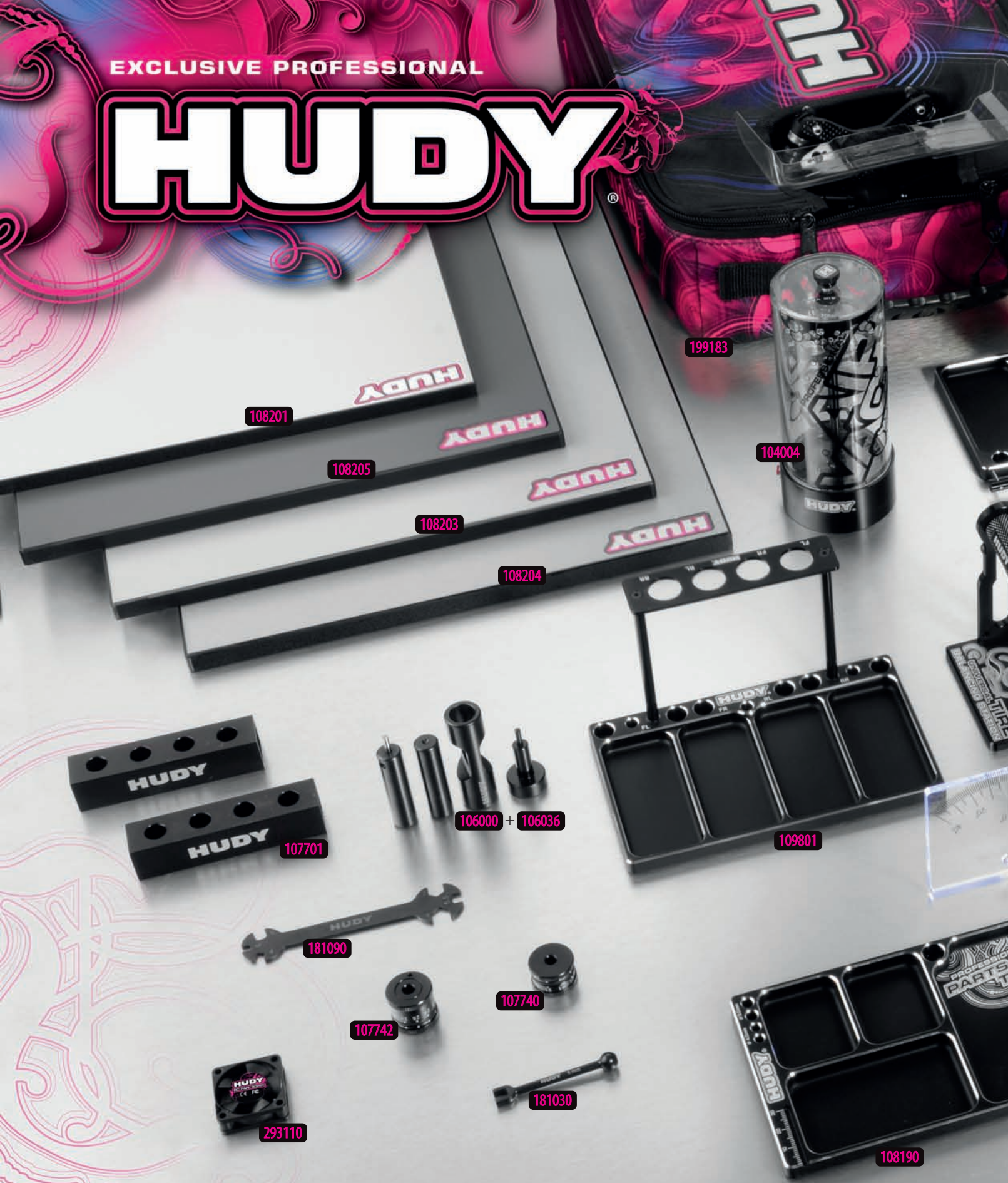

108201

108205

108203

108204

199183

104004

107701

106000 + 106036

109801

181090

107740

107742

181030

293110

108190

- 104004 HUDY AIR VAC - VACUUM PUMP - 1/10 OFF-ROAD
- 105500 HUDY UNIVERSAL TIRE BALANCING STATION
- 105520 WHEEL ADAPTER FOR 1/10 TOURING CARS - 12MM
- 106000 HUDY DRIVE PIN REPLACEMENT TOOL (FOR 3MM PINS)
- 106036 EJECTOR PIVOT PIN & ALTERNATING PIVOT 2.5MM FOR #106000
- 107090 HUDY BEARING CHECKING TOOL
- 107601 LIMITED EDITION - REAMER FOR BODY 0-9MM + COVER - SMALL
- 107701 CHASSIS DROOP GAUGE SUPPORT BLOCKS 20MM FOR 1/8 - LW(2)
- 107740 HUDY ADJUSTABLE RIDE HEIGHT GAUGE 14-20MM
- 107742 HUDY ADJUSTABLE RIDE HEIGHT GAUGE 20-30MM
- 107855 HUDY PIT LED
- 107880 CHASSIS BALANCING TOOL (2)

- 108160 HUDY 1/10 OFF-ROAD CAR STAND - V2
- 108190 HUDY ALU TRAY FOR PARTS
- 108201 FLAT SET-UP BOARD FOR 1/10 TOURING CARS
- 108203 FLAT SET-UP BOARD FOR 1/10 TOURING CARS - SILVER GREY
- 108204 FLAT SET-UP BOARD FOR 1/10 TOURING CARS - TITAN
- 108205 FLAT SET-UP BOARD FOR 1/10 TOURING CARS - DARK GREY
- 108905 UNIVERSAL EXCLUSIVE SET-UP SYSTEM FOR 1/10 OFF-ROAD CARS
- 108960 ALU NUT FOR 1/10 OFF-ROAD SET-UP SYSTEM (4)
- 109801 HUDY ALU TRAY FOR 1/10 OFF-ROAD DIFF & SHOCKS
- 109840 HUDY ALU TRAY FOR 1/10 OFF-ROAD DIFF ASSEMBLY
- 109860 HUDY ALU TRAY FOR SET-UP SYSTEM
- 109880 HUDY ALU TRAY FOR ACCESSORIES & PIT LED

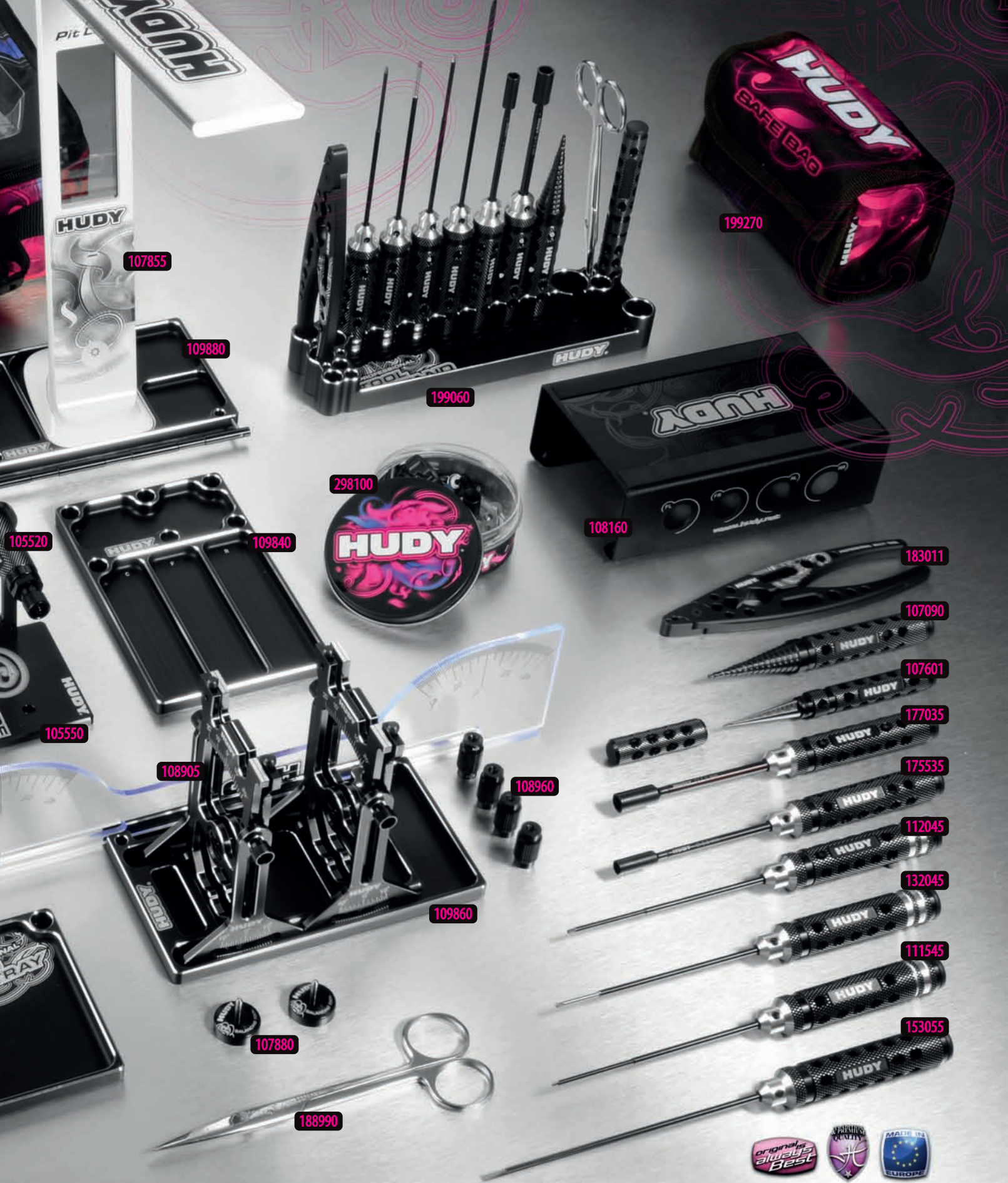

- 111545 LIMITED EDITION - ALLEN WRENCH # 1.5MM
- 112045 LIMITED EDITION - ALLEN WRENCH # 2.0MM
- 132045 LIMITED EDITION - ALLEN WRENCH + BALL REPL. TIP # 2.0MM
- 153055 LIMITED EDITION - SLOTTED SCREWDRIVER # 3.0MM - LONG
- 175535 LIMITED EDITION - SOCKET DRIVER # 5.5MM
- 177035 LIMITED EDITION - SOCKET DRIVER # 7.0MM
- 181030 HUDY SPRING STEEL TURNBUCKLE WRENCH 3 MM
- 181090 HUDY SPECIAL TOOL FOR TURNBUCKLES & NUTS
- 183011 HUDY PROFESSIONAL MULTI TOOL
- 188990 HUDY PROFESSIONAL BODY SCISSORS
- 199060 HUDY ALU TOOL STAND
- 199183 HUDY CAR BAG - 1/10 OFF-ROAD

- 199270 HUDY LIPO SAFETY BAG
- 293110 HUDY BRUSHLESS RC FAN 30MM
- 298100 HUDY TIN ROUND BOX 80X30MM
- 293110XL HUDY BRUSHLESS RC FAN 30MM - SET OF 12PCS

For more information about tools, set-up equipment and accessories suitable for your car please visit:

www.hudy.net



www.teamxray.com

XRAY EUROPE

XRAY, K VÝSTAVISKU 6992, 91101 TRENCIN, SLOVAKIA, EUROPE
PHONE: +421-32-740 11 00, FAX: +421-32-740 11 09, info@teamxray.com

XRAY USA

RC AMERICA, 2030 Century Center Blvd #15, Irving, TX 75062, USA
PHONE: 214-744-2400, FAX: 214-744-2401, xray@rcamerica.com



/TeamXray



/TeamXray



/TeamXray



/TeamXrayRC



/XrayRacing



/XrayRacing