

1/10 LUXURY ELECTRIC OFF-ROAD BUGGY 2WD

XRAY XB2



INSTRUCTION MANUAL
FOR XB2C'24 & XB2D'24 EDITION

BEFORE YOU START

This is a high-competition, high-quality RC car intended for persons aged 16 years and older with previous experience building and operating RC model racing cars. This is not a toy; it is a precision racing model. This model racing car is not intended for use by beginners, inexperienced customers, or by children without direct supervision of a responsible, knowledgeable adult. If you DO NOT fulfill these requirements, please return the kit in unused and unassembled form back to the shop where you have purchased it.

Before building and operating your XRAY, YOU MUST read through all of the operating instructions and instruction manual and fully understand them to get the maximum enjoyment and prevent unnecessary damage.

CUSTOMER SUPPORT

We have made every effort to make these instructions as easy to understand as possible. However, if you have any difficulties, problems, or questions, please DO NOT hesitate to contact the XRAY support team at info@teamxray.com. Also, please visit our Web site at www.teamxray.com to find the latest updates, set-up information, option parts, and many other goodies. We pride ourselves on taking excellent care of our customers.

You can join thousands of XRAY fans and enthusiasts in our online community at:

www.teamxray.com

Read carefully and fully understand the instructions before beginning assembly.

Make sure you review this entire manual, download and use set-up book from the web, and examine all details carefully. If for some reason you decide this is not what you wanted or expected, DO NOT continue any further. Your hobby dealer can not accept your kit for return or exchange after it has been partially or fully assembled.

Contents of the box may differ from pictures. In line with our policy of continuous product development, the exact specifications of the kit may vary without prior notice.

XRAY Europe

K Vystavisku 6992
91101 Trenčín
Slovakia, EUROPE
Phone: 421-32-7401100
Fax: 421-32-7401109
E-mail: info@teamxray.com

XRAY USA

RC America, 2030 Century Center Blvd #15
Irving, TX 75062
USA
Phone: (214) 744-2400
Fax: (214) 744-2401
E-mail: xray@rcamerica.com

FAILURE TO FOLLOW THESE INSTRUCTIONS WILL BE CONSIDERED AS ABUSE AND/OR NEGLIGENCE.

SAFETY PRECAUTIONS

Contains:

LEAD (CAS 7439-92-1) ANTIMONY (CAS 7440-36-0)

WARNING: This product contains a chemical known to the state of California to cause cancer and birth defects or other reproductive harm.

CAUTION: CANCER HAZARD

Contains lead, a listed carcinogen. Lead is harmful if ingested. Wash thoroughly after using. DO NOT use product while eating, drinking or using tobacco products. May cause chronic effects to gastrointestinal tract, CNS, kidneys, and blood. MAY CAUSE BIRTH DEFECTS.

When building, using and/or operating this model always wear protective glasses and gloves.

Take appropriate safety precautions prior to operating this model. You are responsible for this model's assembly and safe operation! Please read the instruction manual before building and operating this model and follow all safety precautions. Always keep the instruction manual at hand for quick

reference, even after completing the assembly. Use only genuine and original authentic XRAY parts for maximum performance. Using any third party parts on this model will void guaranty immediately.

Improper operation may cause personal and/or property damage. XRAY and its distributors have no control over damage resulting from shipping, improper construction, or improper usage. XRAY assumes and accepts no responsibility for personal and/or property damages resulting from the use of improper building materials, equipment and operations. By purchasing any item produced by XRAY, the buyer expressly warrants that he/she is in compliance with all applicable federal, state and local laws and regulation regarding the purchase, ownership and use of the item. The buyer expressly agrees to indemnify and hold harmless XRAY for all claims resulting directly or indirectly from the purchase, ownership or use of the product. By the act of assembling or operating this product, the user accepts all resulting liability. If the buyer is not prepared to accept this liability, then he/she should return this kit in new, unassembled, and unused condition to the place of purchase.



IMPORTANT NOTES - GENERAL

- This product is not suitable for children under 16 years of age without the direct supervision of a responsible and knowledgeable adult.
- Carefully read all manufacturers warnings and cautions for any parts used in the construction and use of your model.
- Assemble this kit only in places away from the reach of very small children.
- First-time builders and users should seek advice from people who have building experience in order to assemble the model correctly and to allow the model to reach its performance potential.
- Exercise care when using tools and sharp instruments.
- Take care when building, as some parts may have sharp edges.
- Keep small parts out of reach of small children. Children must not be allowed to put any parts in their mouth, or pull vinyl bag over their head.
- Read and follow instructions supplied with paints and/or cement, if used (not included in kit).
- Immediately after using your model, DO NOT touch equipment on the model such as the motor and speed controller, because they generate high temperatures. You may seriously burn yourself seriously touching them.
- Follow the operating instructions for the radio equipment at all times.
- DO NOT put fingers or any objects inside rotating and moving parts, as this may cause damage or serious injury as your finger, hair, clothes, etc. may get caught.
- Be sure that your operating frequency is clear before turning on or running your model, and never share the same frequency with somebody else at the same time. Ensure that others are aware of the operating frequency you are using and when you are using it.
- Use a transmitter designed for ground use with RC cars. Make sure that no one else is using the same frequency as yours in your operating area. Using the same frequency at the same time, whether it is driving, flying or sailing, can cause loss of control of the RC model, resulting in a serious accident.
- Always turn on your transmitter before you turn on the receiver in the car. Always turn off the receiver before turning your transmitter off.
- Keep the wheels of the model off the ground when checking the operation of the radio equipment.
- Disconnect the battery pack before storing your model.
- When learning to operate your model, go to an area that has no obstacles that can damage your model if your model suffers a collision.
- Remove any sand, mud, dirt, grass or water before putting your model away.
- If the model behaves strangely, immediately stop the model, check and clear the problem.
- To prevent any serious personal injury and/or damage to property, be responsible when operating all remote controlled models.
- The model car is not intended for use on public places and roads or areas where its operation can conflict with or disrupt pedestrian or vehicular traffic.
- Because the model car is controlled by radio, it is subject to radio interference from many sources that are beyond your control. Since radio interference can cause momentary loss of control, always allow a safety margin in all directions around the model in order to prevent collisions.
- DO NOT use your model:
 - Near real cars, animals, or people that are unaware that an RC car is being driven.
 - In places where children and people gather
 - In residential districts and parks
 - In limited indoor spaces
 - In wet conditions
 - In the street
 - In areas where loud noises can disturb others, such as hospitals and residential areas.
 - At night or anytime your line of sight to the model may be obstructed or impaired in any way.

To prevent any serious personal injury and/or damage to property, please be responsible when operating all remote controlled models.

IMPORTANT NOTES - ELECTRICAL

- Insulate any exposed electrical wiring (using heat shrink tubing or electrical tape) to prevent dangerous short circuits. Take maximum care in wiring, connecting and insulating cables. Make sure cables are always connected securely. Check connectors for if they become loose. And if so, reconnect them securely. Never use RC models with damaged wires. A damaged wire is extremely dangerous, and can cause short-circuits resulting in fire. Please have wires repaired at your local hobby shop.
- Low battery power will result in loss of control. Loss of control can occur due to a weak battery in either the transmitter or the receiver. Weak running battery may also result in an out of control car if your car's receiver power is supplied by the running battery. Stop operation immediately if the car starts to slow down.
- When not using RC model, always disconnect and remove battery.
- DO NOT disassemble battery or cut battery cables. If the running battery short-circuits, approximately 300W of electricity can be discharged, leading to fire or burns. Never disassemble battery or cut battery cables.
- Use a recommended charger for the receiver and transmitter batteries and follow the instructions correctly. Over-charging, incorrect charging, or using inferior chargers can cause the batteries to become dangerously hot. Recharge battery when necessary. Continual recharging may damage battery and, in the worst case, could build up heat leading to fire. If battery becomes extremely hot during recharging, please ask your local hobby shop for check and/or repair and/or replacement.
- Regularly check the charger for potential hazards such as damage to the cable, plug, casing or other defects. Ensure that any damage is rectified before using the charger again. Modifying the charger may cause short-circuit or overcharging leading to a serious accident. Therefore DO NOT modify the charger.
- Always unplug charger when recharging is finished.
- DO NOT recharge battery while battery is still warm. After use, battery retains heat. Wait until it cools down before charging.
- DO NOT allow any metal part to short circuit the receiver batteries or other electrical/electronic device on the model.
- Immediately stop running if your RC model gets wet as may cause short circuit.
- Please dispose of batteries responsibly. Never put batteries into fire.

R/C & BUILDING TIPS

- Make sure all fasteners are properly tightened. Check them periodically.
- Make sure that chassis screws DO NOT protrude from the chassis.
- For the best performance, it is very important that great care is taken to ensure the free movement of all parts.
- Clean all ball-bearings so they move very easily and freely.
- Tap or pre-thread the plastic parts when threading screws.
- Self-tapping screws cut threads into the parts when being tightened. DO NOT use excessive force when tightening the self-tapping screws because you may strip out the thread in the plastic. We recommended you stop tightening a screw when you feel some resistance.
- Ask your local hobby shop for any advice.

Please support your local hobby shop. We at XRAY Model Racing Cars support all local hobby dealers. Therefore we ask you, if at all possible, to purchase XRAY products at your hobby dealer and give them your support like we do. If you have difficulty finding XRAY products, please check out www.teamxray.com to get advice, or contact us via email at info@teamxray.com, or contact the XRAY distributor in your country.

WARRANTY

XRAY guarantees this model kit to be free from defects in both material and workmanship within 30 days of purchase. The total monetary value under warranty will in no case exceed the cost of the original kit purchased. This warranty DOES NOT cover any components damaged by use or modification or as a result of wear. Part or parts missing from this kit must be reported within 30 days of purchase. No part or parts will be sent under warranty without proof of purchase. Should you find a defective or missing part, contact the local distributor. Service and customer support will be provided through local hobby store where you have purchased the kit, therefore make sure to purchase any XRAY products at your local hobby store. This model racing car is considered to be a high-performance racing vehicle. As such this vehicle will be used in an extreme range of conditions and situations, all which may cause premature wear or failure of any component. XRAY has no control over usage of vehicles once they leave the dealer, therefore XRAY can only offer warranty against all manufacturer's defects in materials, workmanship, and assembly at point of sale and before use. No warranties are expressed or implied that cover damage caused by what is considered normal use, or cover or imply how long any model cars' components or electronic components will last before requiring replacement.

Due to the high performance level of this model car you will need to periodically maintain and replace consumable components. Any and all warranty coverage will not cover replacement of any part or component damaged by neglect, abuse, or improper or unreasonable use. This includes

but is not limited to damage from crashing, chemical and/or water damage, excessive moisture, improper or no maintenance, or user modifications which compromise the integrity of components. Warranty will not cover components that are considered consumable on RC vehicles. XRAY DOES NOT pay nor refund shipping on any component sent to XRAY or its distributors for warranty. XRAY reserves the right to make the final determination of the warranty status of any component or part.

Limitations of Liability

XRAY makes no other warranties expressed or implied. XRAY shall not be liable for any loss, injury or damages, whether direct, indirect, special, incidental, or consequential, arising from the use, misuse, or abuse of this product and/or any product or accessory required to operate this product. In no case shall XRAY's liability exceed the monetary value of this product.

Take adequate safety precautions prior to operating this model. You are responsible for this model's assembly and safe operation.

Disregard of the any of the above cautions may lead to accidents, personal injury, or property damage. XRAY MODEL RACING CARS assumes no responsibility for any injury, damage, or misuse of this product during assembly or operation, nor any addictions that may arise from the use of this product.

All rights reserved.

QUALITY CERTIFICATE

XRAY MODEL RACING CARS uses only the highest quality materials, the best compounds for molded parts and the most sophisticated manufacturing processes of TQM (Total Quality Management). We guarantee that all parts of a newly-purchased kit are manufactured with the highest regard to quality. However, due to the many factors inherent in model racecar competition, we

cannot guarantee any parts once you start racing the car. Products which have been worn out, abused, neglected or improperly operated will not be covered under warranty.

We wish you enjoyment of this high-quality and high-performance RC car and wish you best success on the track!

In line with our policy of continuous product development, the exact specifications of the kit may vary. In the unlikely event of any problems with your new kit, you should contact the model shop where you purchased it, quoting the part number.

We do reserve all rights to change any specification without prior notice. All rights reserved.

TOOLS REQUIRED



Combination Pliers (HUDY #189020)

Side Cutters (HUDY #189010)

Pocket Hobby Knife (HUDY #188981)

Special Tool for turnbuckles, nuts (HUDY #181090)

Turnbuckle Wrench 3mm (HUDY #181030)

HUDY Tweezers Straight (HUDY #188970)

HUDY Tweezers Curved (HUDY #188971)

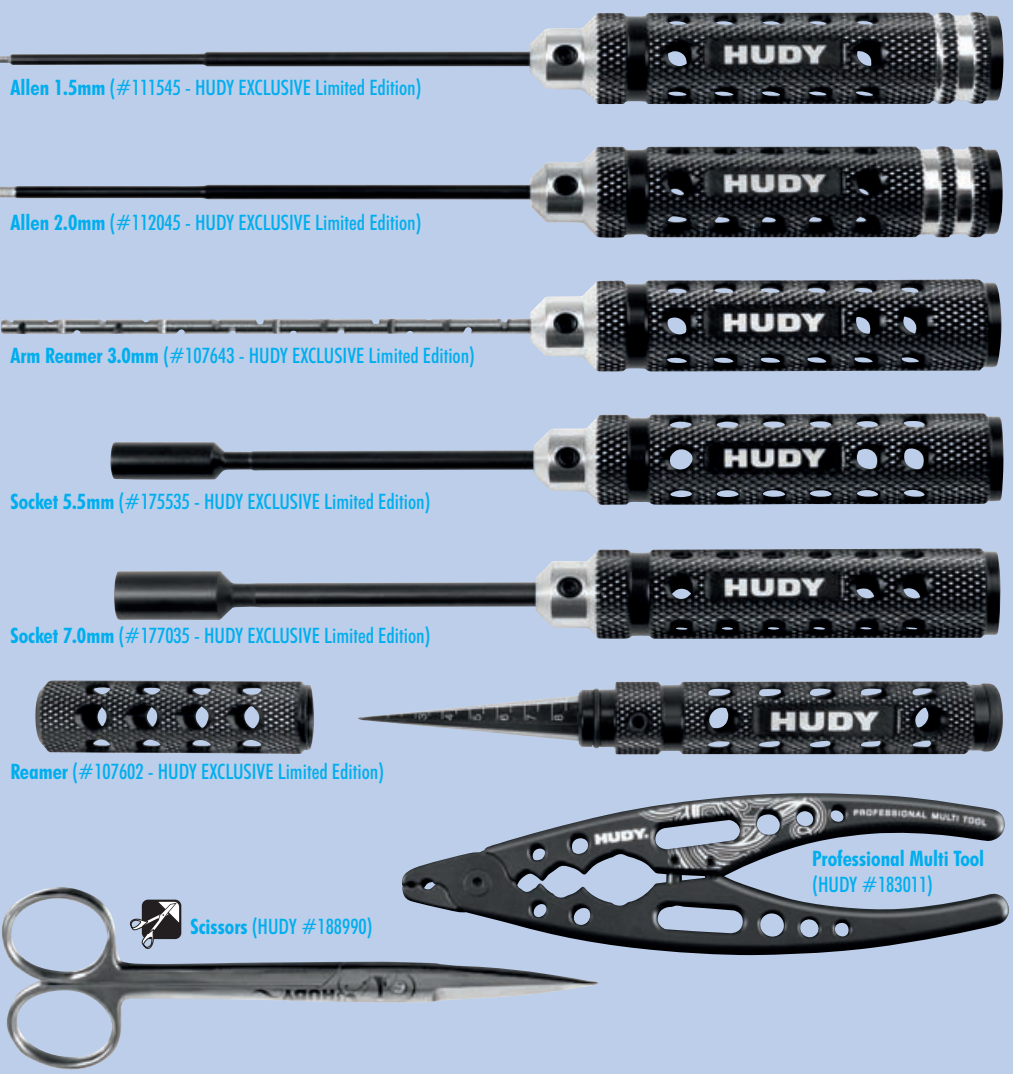

Allen 1.5mm (#111545 - HUDY EXCLUSIVE Limited Edition)

Allen 2.0mm (#112045 - HUDY EXCLUSIVE Limited Edition)

Arm Reamer 3.0mm (#107643 - HUDY EXCLUSIVE Limited Edition)

Socket 5.5mm (#175535 - HUDY EXCLUSIVE Limited Edition)

Socket 7.0mm (#177035 - HUDY EXCLUSIVE Limited Edition)

Reamer (#107602 - HUDY EXCLUSIVE Limited Edition)

Scissors (HUDY #188990)

Professional Multi Tool (HUDY #183011)

EQUIPMENT INCLUDED * Kit includes smaller but sufficient amount of oil and grease to build the car.



300cSt (#106330) HUDY Premium Silicone Oils

10.000cSt (#106510) HUDY Premium Silicone Oils

(HUDY #106211) Premium Diff Grease

(HUDY #106210) Premium Graphite Grease

EQUIPMENT REQUIRED



Transmitter

Receiver

Speed Controller

Steering Servo

Electric Motor & Pinion Gear with Setscrew

LiPo Battery

Battery Charger

Double-sided Tape (HUDY #107875)

Lexan™ Paint

4x Tires & Inserts

Bearing Oil (HUDY #106230)

Threadlock

CA glue

NOT INCLUDED



Follow Set-Up Book:

To ensure that you always have access to the most up-to-date version of the Set-up Book you can download the HUDY Set-up Book from their web site at [www.hudy.net] By offering this online version instead of including a hardcopy printed version in kits, you will always be assured of having the most current updated version.



SAMPLE OF OPTIONAL PARTS

#32XXXX	TYPE1	OPTION 1
#32XXXX	TYPE2	OPTION 2
#32XXXX	TYPE	INCLUDED
#32XXXX	TYPE3	OPTION 3

XRAY offers wide range of optional tuning parts which are listed in a table like this. Please refer to the exploded view of each main section to verify which part is included in the kit while all other parts are available only as an optional part and must be purchased separately.

COLOR INDICATIONS

At the beginning of each section is an exploded view of the parts to be assembled. There is also a list of all the parts and part numbers that are related to the assembly of that section.

The part descriptions are color-coded to make it easier for you to identify the source of a part. Here are what the different colors mean:

321200

STYLE A - indicates parts that are included in the bag marked for the section.

321100

STYLE B - indicates parts that are included in the box.

324900

STYLE C - indicates parts that are already assembled from previous steps.

325100

STYLE D - indicates parts that are optional.

TECH TIPS

TIP DRIVE SHAFT PIN SERVICING

To enjoy the longest possible lifespan of the drive shafts and diff outdrives, it is extremely important to properly service the drive shaft pins. Inspect the pins after every 3 hours of runtime. If the pins show any wear, replace them with new pins.



DO NOT use drive shafts when the pins are worn.

Press out the worn pins.

Press in new pins and regularly inspect for wear.



For quick & easy drive pin replacements use #106000 HUDY Drive Pin Replacement Tool together with #106036 Ejector Pivot Pin & Alternating Pivot 2.5mm.



To replace the worn pins use only premium HUDY drive pins (#106053 2.5mm dia x 10mm length)

TIP GRAPHITE PARTS PREPARATION

Follow this Tech Tip to prepare the graphite parts. Sand the edges with sandpaper, and then seal the edges with CA glue to reinforce them and help prevent delamination.

Prepare all Graphite Parts:

- Front shock tower
- Rear shock tower

Fine sandpaper

Use fine sandpaper to sand smooth the edges of all graphite parts.

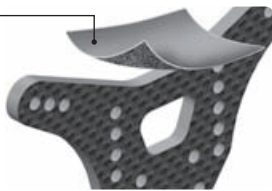

Apply CA glue to all edges of the graphite parts.

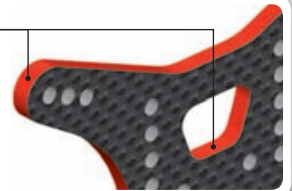

MANUAL STEPS ONLY FOR DIRT

1. BALL DIFFERENTIAL **DIRT**

SAG 07

MANUAL STEPS ONLY FOR CARPET

1. GEAR DIFFERENTIAL **CARPET**

SAG 07

MANUAL DUAL STEPS FOR CARPET AND DIRT

3. REAR DRIVETRAIN **CARPET** **DIRT**

1. GEAR DIFFERENTIAL

GEAR DIFF CASES			
#324912	HARD	INCLUDED	
#324912-G	GRAPHITE	OPTION	
GEAR DIFF PULLEYS			
#324955	HARD	INCLUDED	
#324955-G	GRAPHITE	OPTION	

#325101 XRAY XB2 ACTIVE DIFF - NARROW - SET

ACTIVE DIFF SEGMENTS			
#325123	60°		OPTION
#325125	90°		OPTION
#325127	120°		INCLUDED

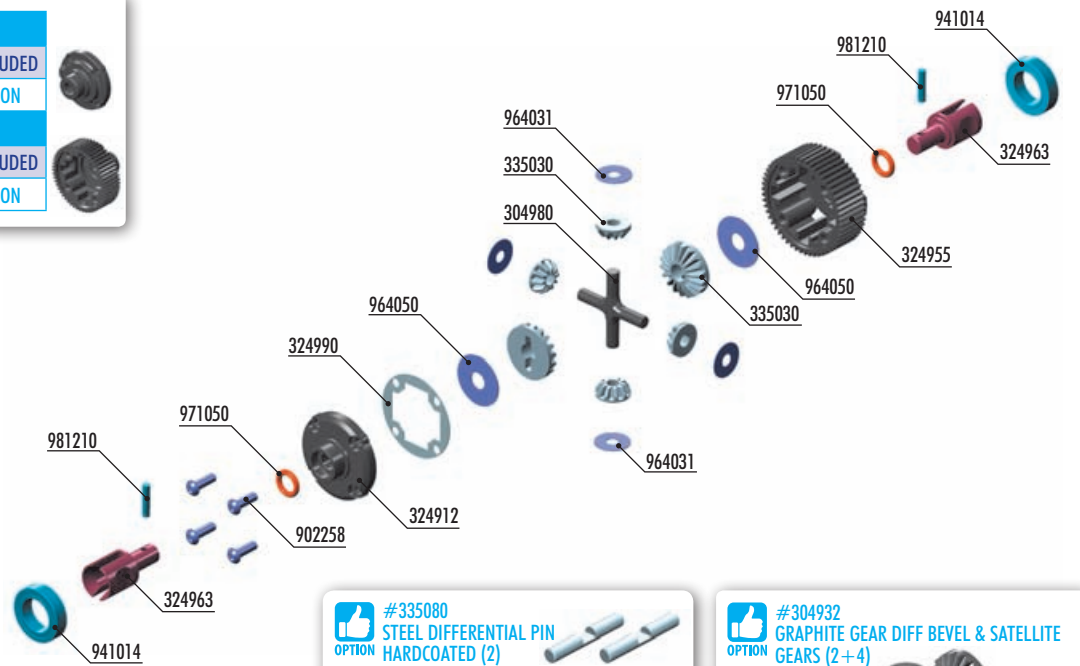

#335080 STEEL DIFFERENTIAL PIN HARDCOATED (2)

#335081 ALU DIFFERENTIAL PIN HARDCOATED (2)

#304932 GRAPHITE GEAR DIFF BEVEL & SATELLITE GEARS (2+4)



- | | | | |
|--------|---|--------|---|
| 304980 | COMPOSITE GEAR DIFF CROSS PIN | 902258 | HEX SCREW SH M2.5x8 (10) |
| 324990 | DIFF GASKET (4) | 941014 | BALL-BEARING 10x15x4 RUBBER SEALED - GREASE (2) |
| 324903 | GEAR DIFFERENTIAL - LCG - NARROW - SET | 964031 | WASHER S 3.5x10x0.2 (10) |
| 324912 | COMPOSITE GEAR DIFFERENTIAL COVER - LCG - NARROW | 964050 | WASHER S 5x15x0.3 (10) |
| 324955 | COMPOSITE GEAR DIFFERENTIAL CASE WITH PULLEY 53T - LCG - NARROW | 971050 | SILICONE O-RING 5x1.5 (10) |
| 324963 | GEAR DIFF OUTDRIVE ADAPTER - LCG - FOR NARROW DIFF - HSS™ (2) | 981210 | PIN 2x10 (10) |
| 335030 | STEEL DIFF BEVEL & SATELLITE GEARS (2+4) | | |

- 1x 964050 S 5x15x0.3
- 1x 971050 O 5x1.5
- 1x 981210 P 2x10

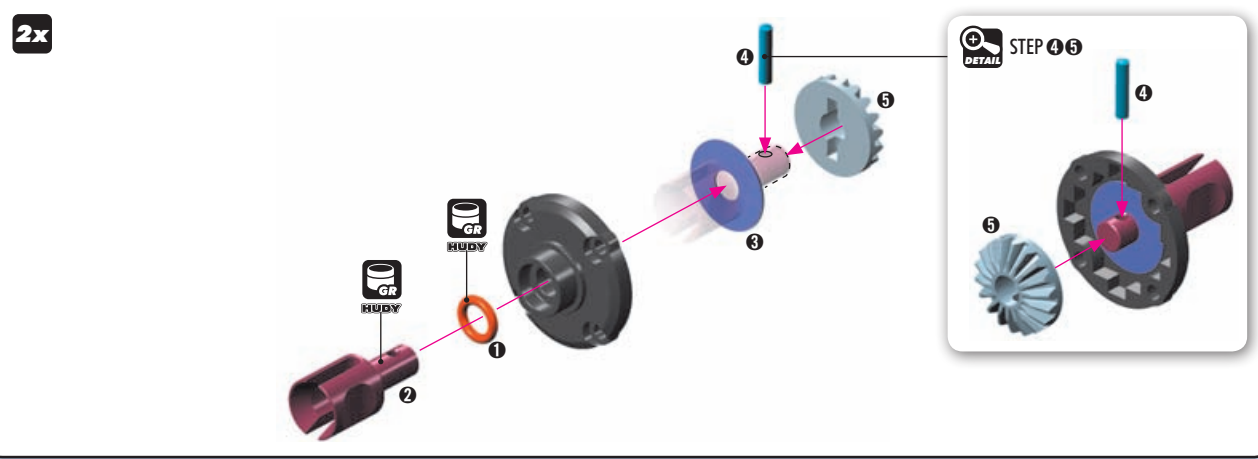

- 1x 964050 S 5x15x0.3
- 1x 971050 O 5x1.5
- 1x 981210 P 2x10

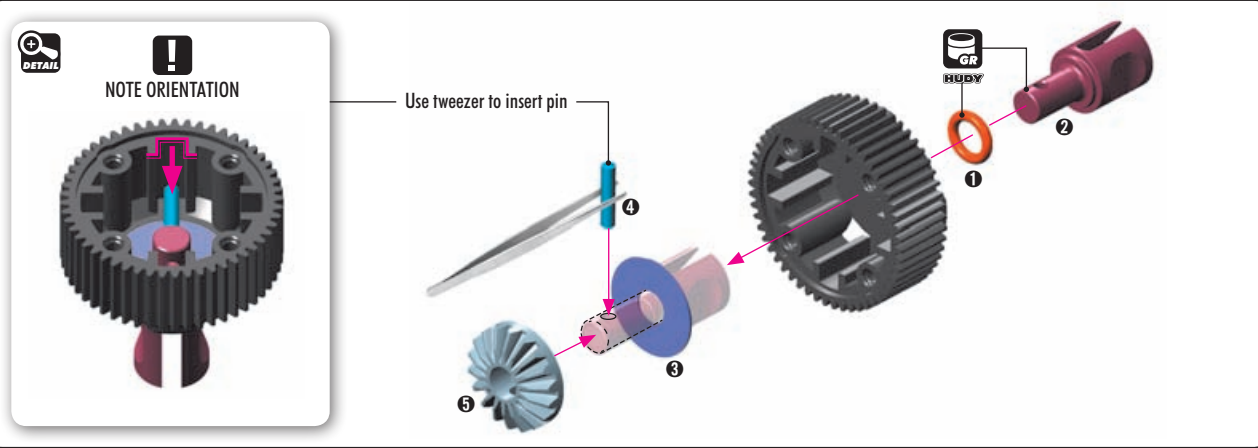

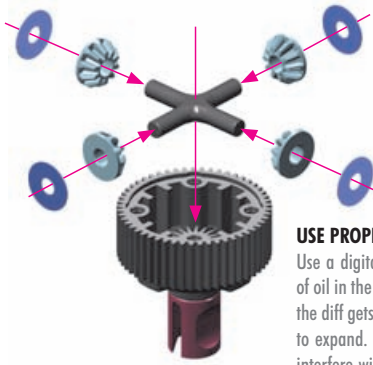

USE PROPER AMOUNT OF OIL IN THE DIFFS
Use a digital scale to measure the exact amount of oil in the diff. Remember that during operation the diff gets hotter and the heat may allow the oil to expand. If there is too much oil inside it may interfere with the diff operation and damage the internal gears.

Rear diff
Silicone oil **10.000cSt**
Fill just above the diff pin.



Fill differential up to the top of the diff pin.

DO NOT fill the diff to the top of the housing.



TO ENSURE YOU HAVE THE SAME AMOUNT OF OIL FROM REBUILD TO REBUILD, DO THE FOLLOWING:

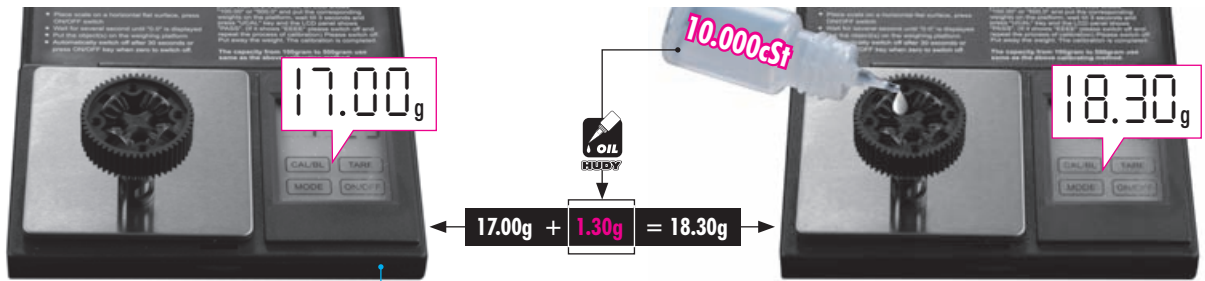

1 Put the diff (without oil) on the scale and check the weight (approximately 17.00g)

#107865
HUDY Professional Digital Pocket Scale 300g/0.01g

#107866
HUDY Professional Digital Pocket Scale 3000g/0.1g

2 Slowly pour oil into the diff and watch the weight. Add 1.30g of oil into the diff. The approximate weight of the diff including oil is 18.30g.

TIP TIPS FOR REAR DIFFERENTIAL

- LOW-MEDIUM TRACTION 5.000cSt (HUDY #106450)
- MEDIUM-HIGH TRACTION 15.000cSt (HUDY #106515)

NOTE: Softer oil increases rear traction, harder oil increases on-power steering.

HUDY ULTIMATE SILICONE OILS		
#106440	4.000cSt - 50ml	OPTION
#106450	5.000cSt - 50ml	OPTION
#106460	6.000cSt - 50ml	OPTION
#106470	7.000cSt - 50ml	OPTION
#106480	8.000cSt - 50ml	OPTION
#106490	9.000cSt - 50ml	OPTION
#106510	10.000cSt - 50ml	INCLUDED
#106492	11.000cSt - 50ml	OPTION
#106512	12.000cSt - 50ml	OPTION
#106513	13.000cSt - 50ml	OPTION
#106515	15.000cSt - 50ml	OPTION
#106520	20.000cSt - 50ml	OPTION
#106530	30.000cSt - 50ml	OPTION
#106540	40.000cSt - 50ml	OPTION
#106550	50.000cSt - 50ml	OPTION
#106560	60.000cSt - 50ml	OPTION
#106580	80.000cSt - 50ml	OPTION

SET-UP BOOK

DIFFERENTIAL OIL

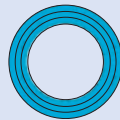
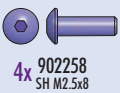

2x 941014 BB 10x15x4



Install the screws equally but **DO NOT** tighten them completely.

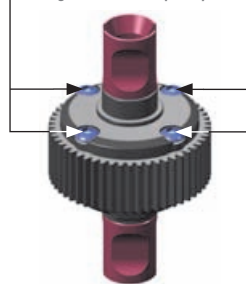

Finish tightening in this order.

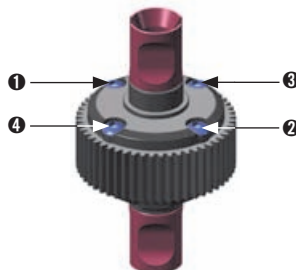

Use HUDY Ball-Bearing Grease

- #106220 - STANDARD
- #106221 - BLUE
- #106222 - RED

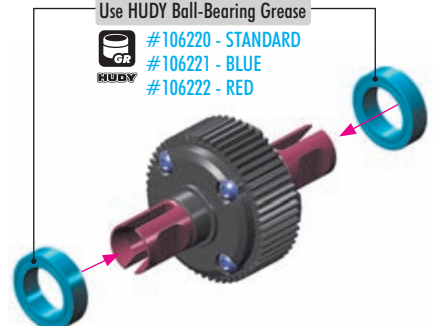

1. BALL DIFFERENTIAL

DIRT

#325101 XRAY XB2 ACTIVE
DIFF - NARROW - SET



ACTIVE DIFF SEGMENTS

#325123	60°		OPTION
#325125	90°		OPTION
#325127	120°		INCLUDED

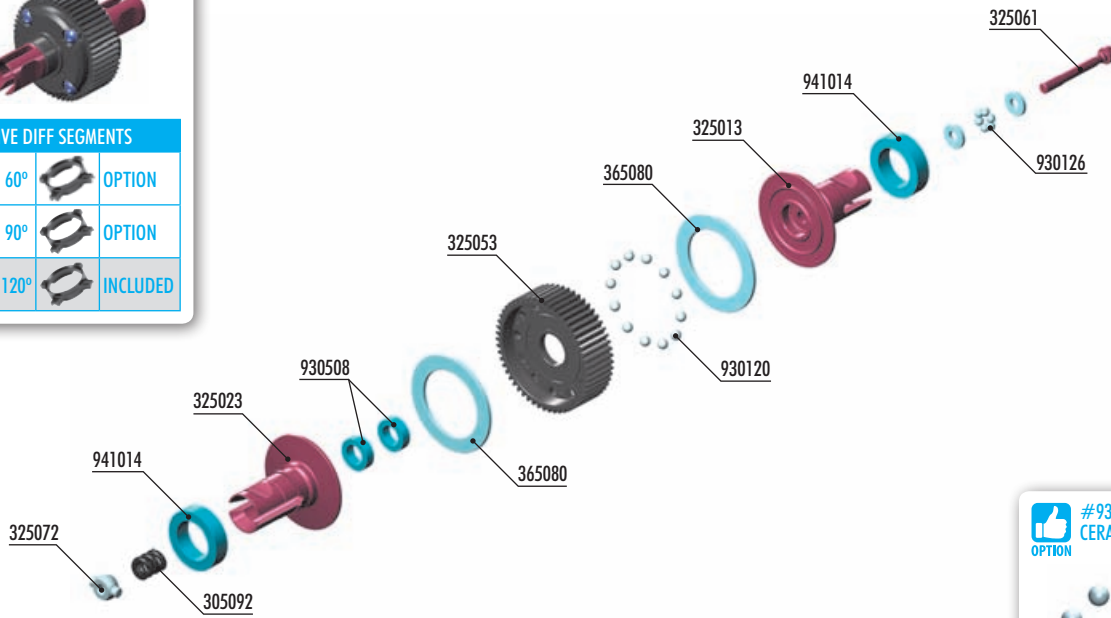

#930220
CERAMIC BALL 2.4MM (12)



BAG



- | | | | |
|--------|---|--------|---|
| 305092 | BALL DIFFERENTIAL SPRING | 325072 | ALU BALL DIFFERENTIAL NUT |
| 325003 | BALL ADJUSTABLE DIFFERENTIAL - LCG - SET - HUDY SPRING STEEL™ | 365080 | DIFF WASHER 17 x 24.5 x 1 (2) |
| 325013 | BALL DIFFERENTIAL SHORT OUTPUT SHAFT - LCG - HUDY SPRING STEEL™ | 930120 | CARBIDE BALL 2.4mm FOR BALL DIFF (12) |
| 325023 | BALL DIFFERENTIAL LONG OUTPUT SHAFT - LCG - HUDY SPRING STEEL™ | 930126 | CARBIDE BALL-BEARING AXIAL 2.6x6x1 |
| 325053 | COMPOSITE BALL DIFFERENTIAL GEAR 53T | 930508 | BALL-BEARING 5x8x2.5 STEEL SEALED - OIL (2) |
| 325061 | SCREW FOR BALL DIFF ADJUSTMENT - SPRING STEEL™ | 941014 | BALL-BEARING 10x15x4 RUBBER SEALED - GREASE (2) |



1x 930126
BA 2.6x6x1

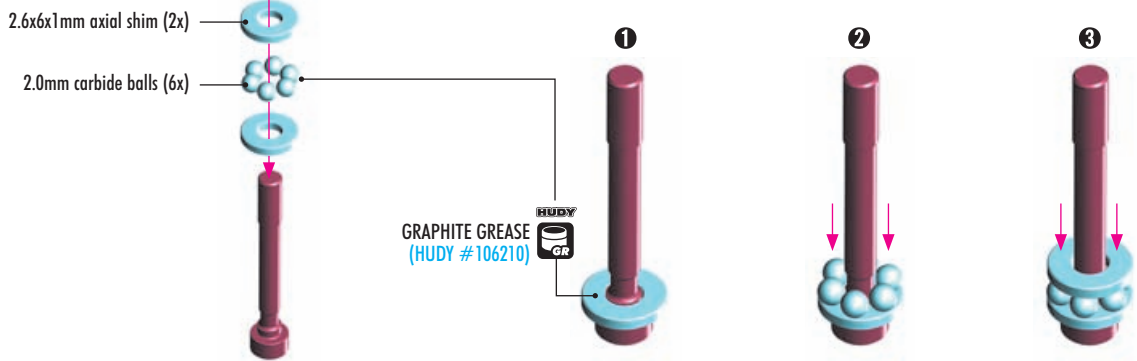

1. BALL DIFFERENTIAL



2x 930508
BB 5x8x2.5

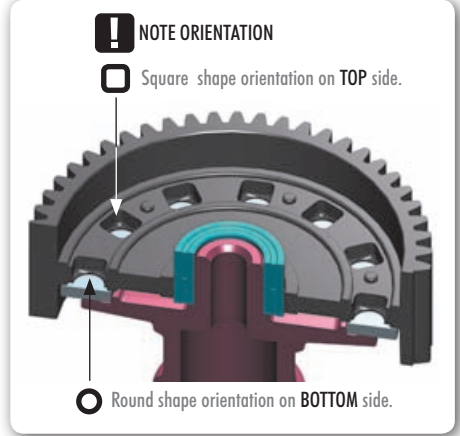
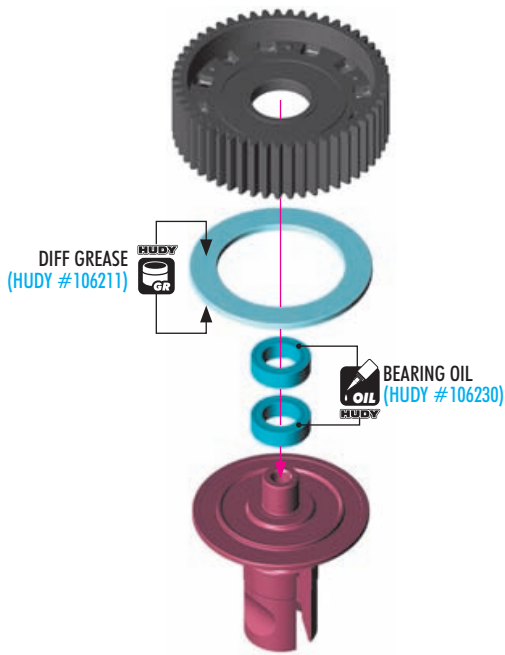

12x 930120
B 2.4

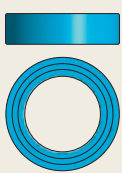
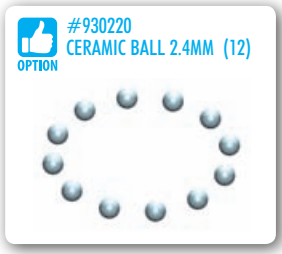
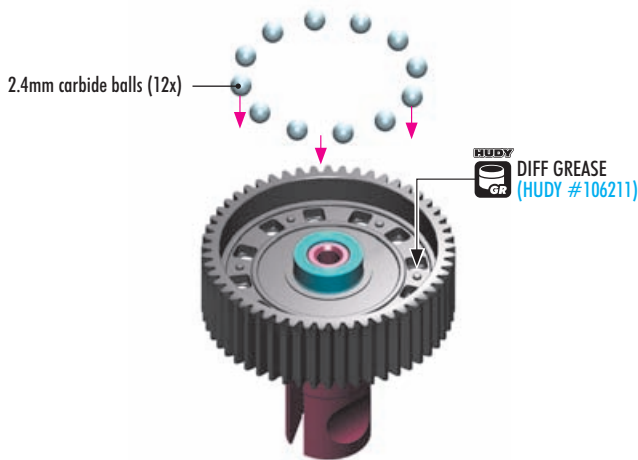

2x 941014
BB 10x15x4

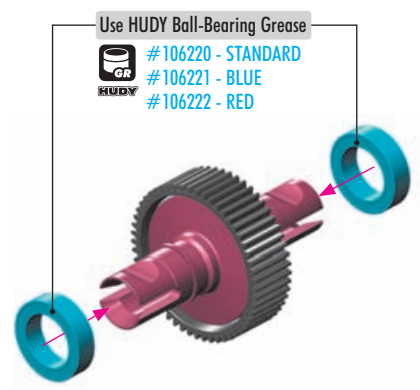
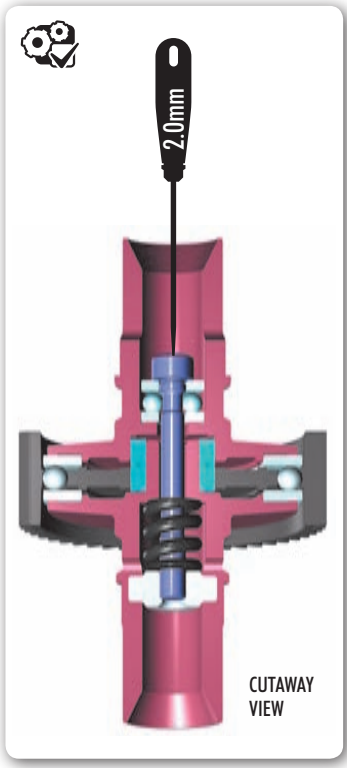
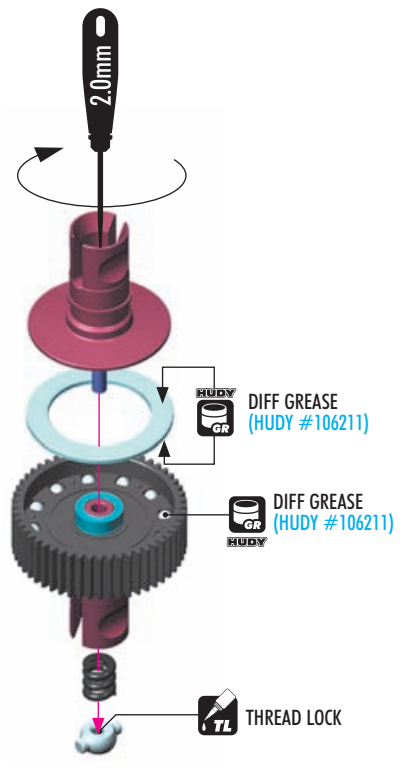



BEFORE RACING, follow these steps to properly break in the differential.

1

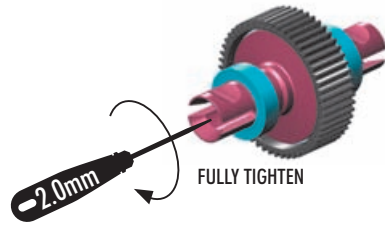

2 Loosen the adjustment screw 1/2 turn (180° CCW).

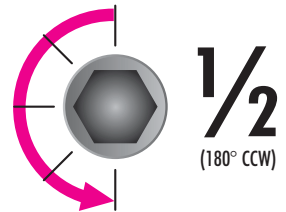
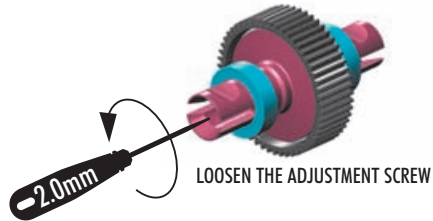

3

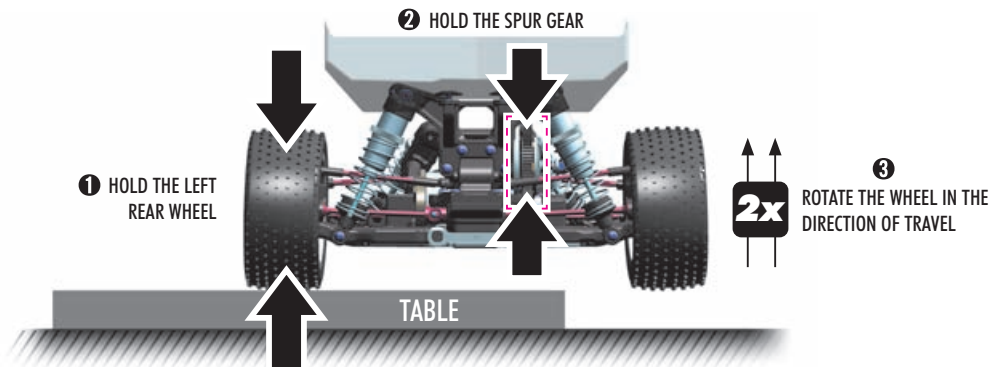

4

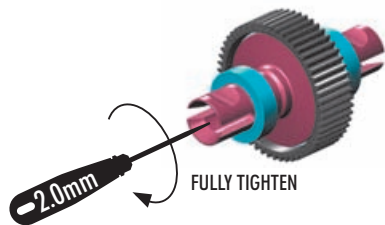

5 LOOSEN THE ADJUSTMENT SCREW 1/8 TURN (45° CCW).

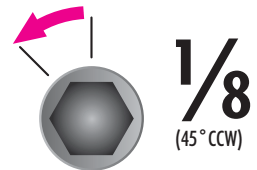
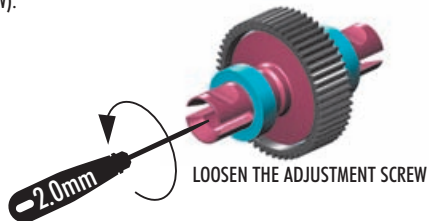

2. REAR TRANSMISSION **CARPET** **DIRT**

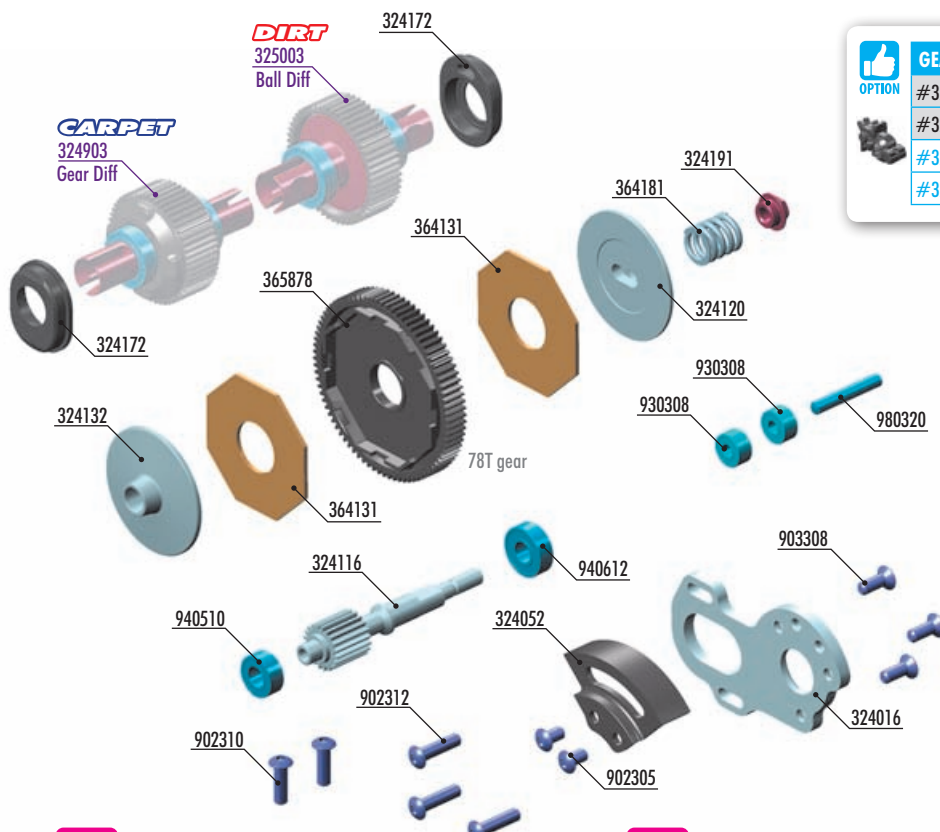

OPTION	GEAR BOXES	CARPET	DIRT
#323018	REAR MOTOR COMPOSITE	INCLUDED	INCLUDED
#323019	FRONT MOTOR COMPOSITE	INCLUDED	INCLUDED
#323018-G	REAR MOTOR GRAPHITE	OPTION	OPTION
#323019-G	FRONT MOTOR GRAPHITE	OPTION	OPTION

BAG REAR MOTOR POSITION

BAG FRONT MOTOR POSITION

• DIRT low & high grip • WET ASTRO

• CARPET • Dry ASTRO • DIRT very high traction



GEAR BOX ALTERNATIVE 1

→ REAR MOTOR POSITION

We recommend for these types of surfaces and traction:
 - DIRT low & high traction
 - WET ASTRO



GEAR BOX ALTERNATIVE 2

← FRONT MOTOR POSITION

We recommend for these types of surfaces and traction:
 - CARPET
 - Dry ASTRO
 - DIRT very high traction

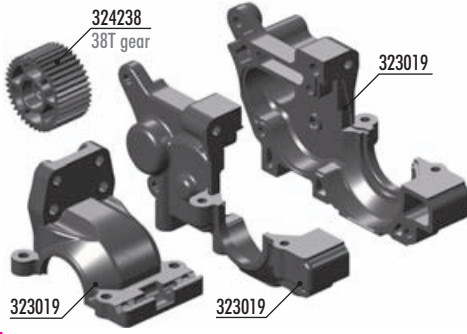
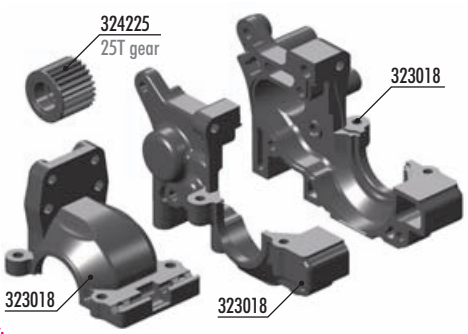

OPTION	SPUR GEARS	CARPET	DIRT
#365875	75T	OPTION	OPTION
#365878	78T	INCLUDED	INCLUDED
#365881	81T	OPTION	OPTION



BAG 02

- | | | | |
|--------|--|--------|---|
| 323018 | COMPOSITE REAR MOTOR GEAR BOX - LCG - SET | 902305 | HEX SCREW SH M3x5 (10) |
| 323019 | COMPOSITE FRONT MOTOR GEAR BOX - LCG - SET | 902310 | HEX SCREW SH M3x10 (10) |
| 324016 | ALU MOTOR PLATE - LCG - SWISS 7075 T6 | 902312 | HEX SCREW SH M3x12 (10) |
| 324052 | COMPOSITE GEAR COVER - LCG | 903308 | HEX SCREW SFH M3x8 (10) |
| 324116 | ALU 2-PAD TOP SHAFT 20T - LCG - ULTRA-LIGHTWEIGHT - SHORT | 930308 | BALL-BEARING 3x8x4 STEEL SEALED - OIL (2) |
| 324120 | ALU 3-PAD SLIPPER CLUTCH PLATE - SWISS 7075 T6 - HARD COATED | 940510 | BALL-BEARING 5x10x4 RUBBER SEALED - OIL (2) |
| 324132 | ALU 2-PAD SLIPPER CLUTCH PLATE 31MM WITH ADAPTER - LCG - 7075 T6 | 940612 | BALL-BEARING 6x12x4 RUBBER SEALED - OIL (2) |
| 324172 | COMPOSITE ADJUSTMENT BALL-BEARING HUB (2) | 980320 | PIN 3x20 (10) |
| 324191 | STEEL SLIPPER CLUTCH NUT - HUDY SPRING STEEL™ | | |
| 324225 | COMPOSITE GEAR 25T - GRAPHITE | | |
| 324238 | COMPOSITE GEAR 38T - LCG - GRAPHITE | | |
| 364131 | SLIPPER CLUTCH PAD SLS - SOFT (3) | | |
| 364181 | SLIPPER CLUTCH SPRING C=45 - BLACK | | |
| 365878 | COMPOSITE 3-PAD SLIPPER CLUTCH SPUR GEAR 78T / 48 | | |

CARPET

324903 GEAR DIFFERENTIAL - LCG - NARROW - SET

DIRT

325003 BALL ADJUSTABLE DIFFERENTIAL - LCG - SET - HUDY SPRING STEEL™

-  3x 902312 SH M3x12
-  2x 930308 BB 3x8x4
-  1x 940510 BB 5x10x4
-  1x 940612 BB 6x12x4
-  1x 980320 P 3x20



- DIRT surface low & high grip
- WET ASTRO surface

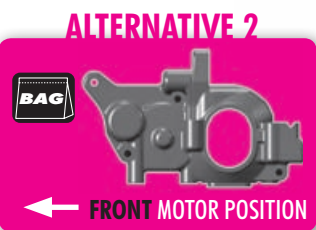
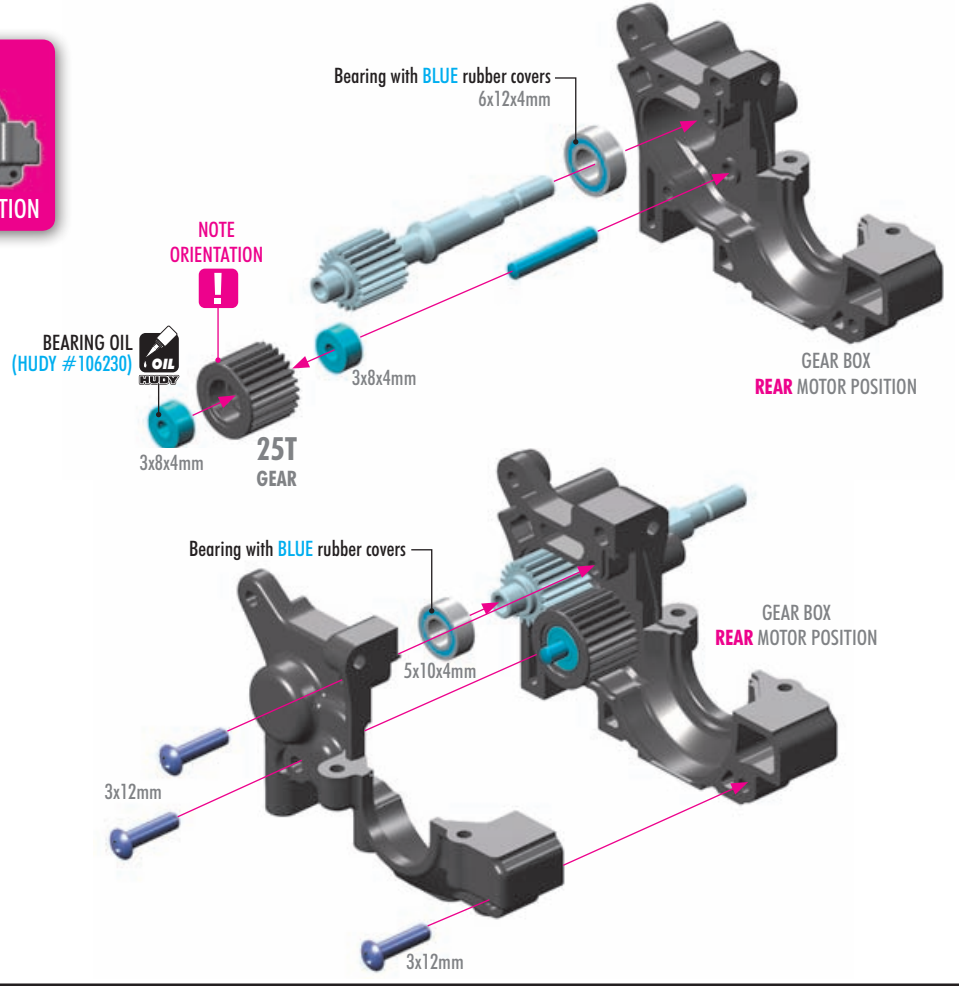

- CARPET
- ASTRO surface
- DIRT very high traction

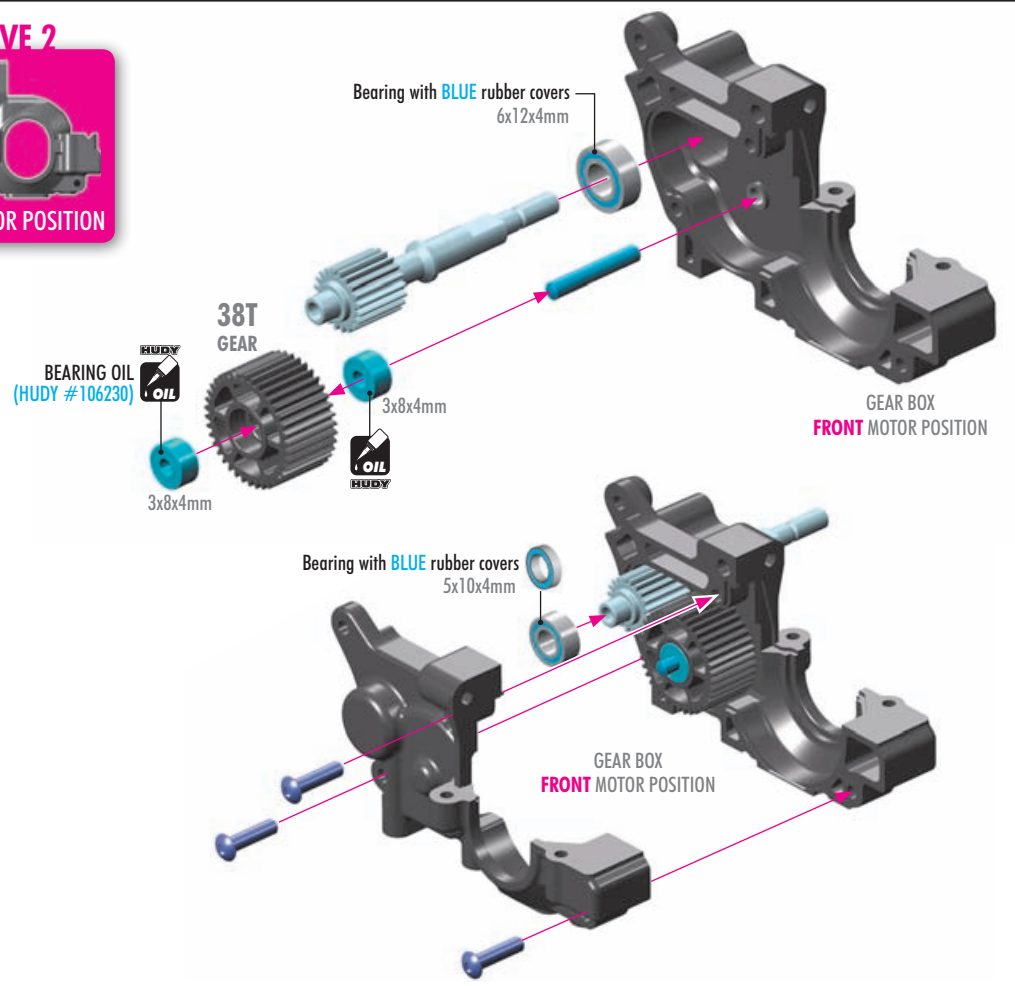

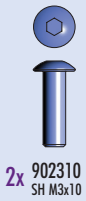

ALTERNATIVE 1

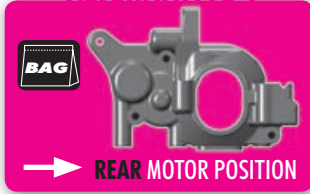

- DIRT surface low & high grip
- WET ASTRO surface

NOTE DIFF ORIENTATION

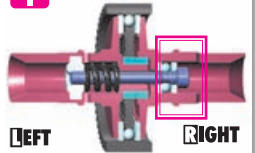

Ball differential must always be oriented with the screw on the right side. If the ball differential is oriented with the screw on the left side, the ball diff will become loose when the car is running.

DIFFERENTIAL HEIGHT ADJUSTMENT DIRT

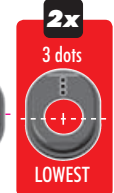
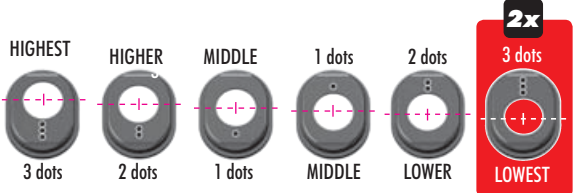

Dots must have same orientation on each side (dots up or down).

NOTE ORIENTATION

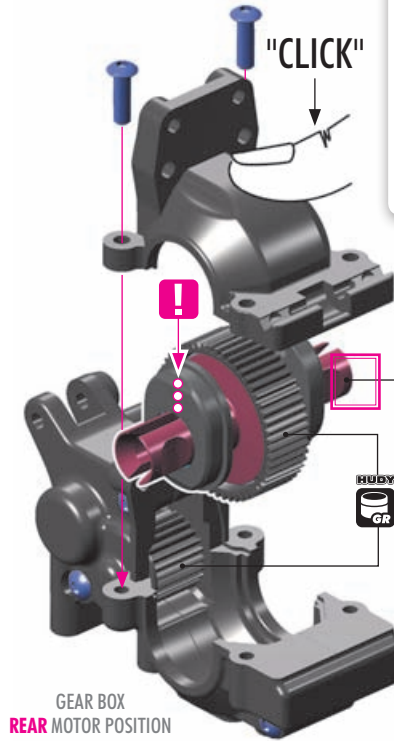
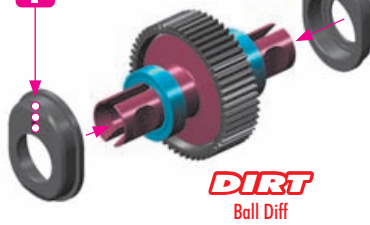

GRAPHITE GREASE (HUDY #106210)

GEAR RATIO
Internal Gear Ratio 2.65

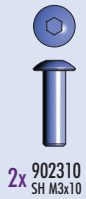

ALTERNATIVE 2

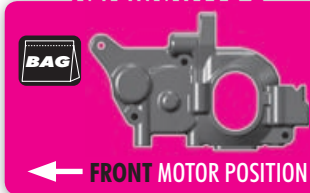

- CARPET
- ASTRO surface
- DIRT very high traction

DIFFERENTIAL HEIGHT ADJUSTMENT CARPET

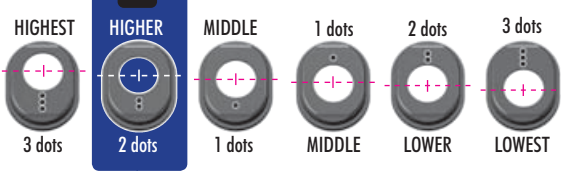

INITIAL SETTING

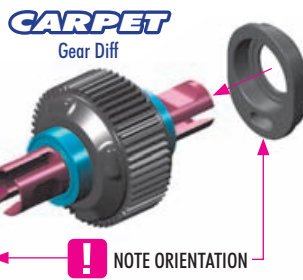

Dots must have same orientation on each side (dots up or down).

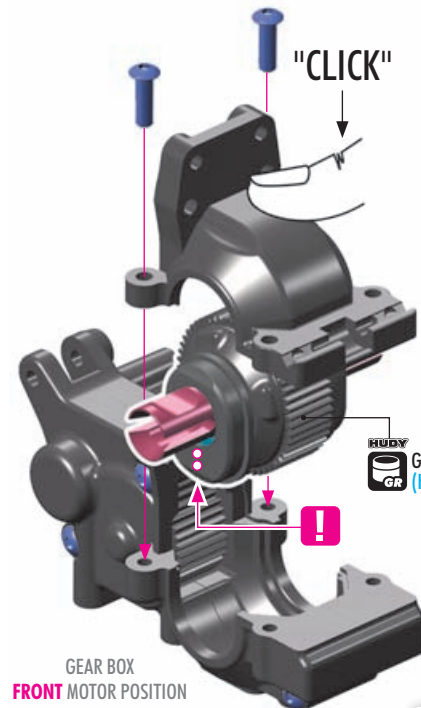

GRAPHITE GREASE (HUDY #106210)

GEAR RATIO
Internal Gear Ratio 2.65

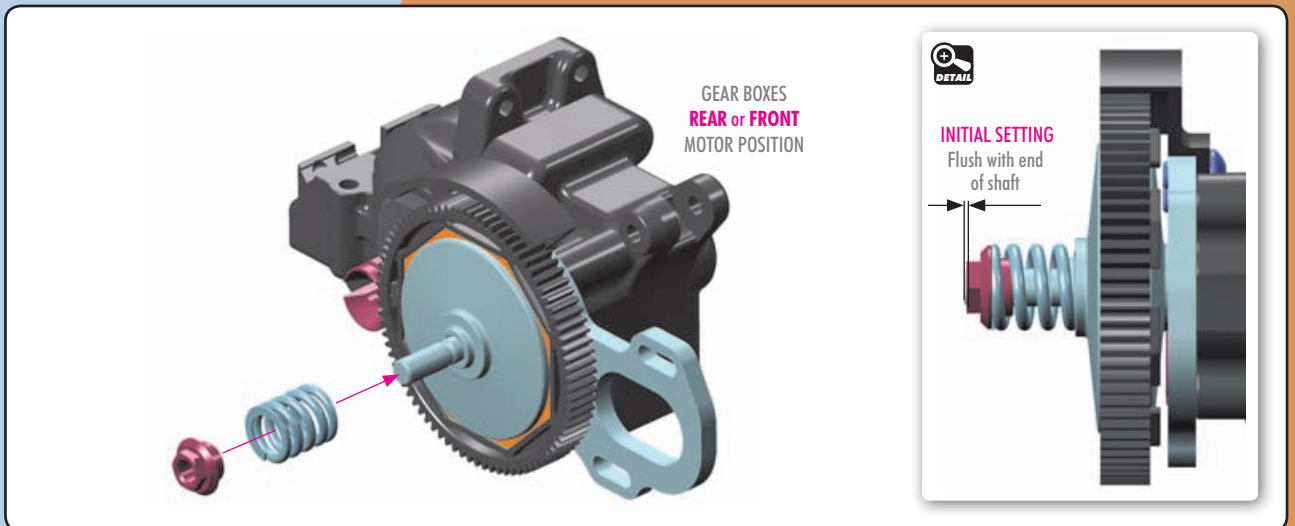
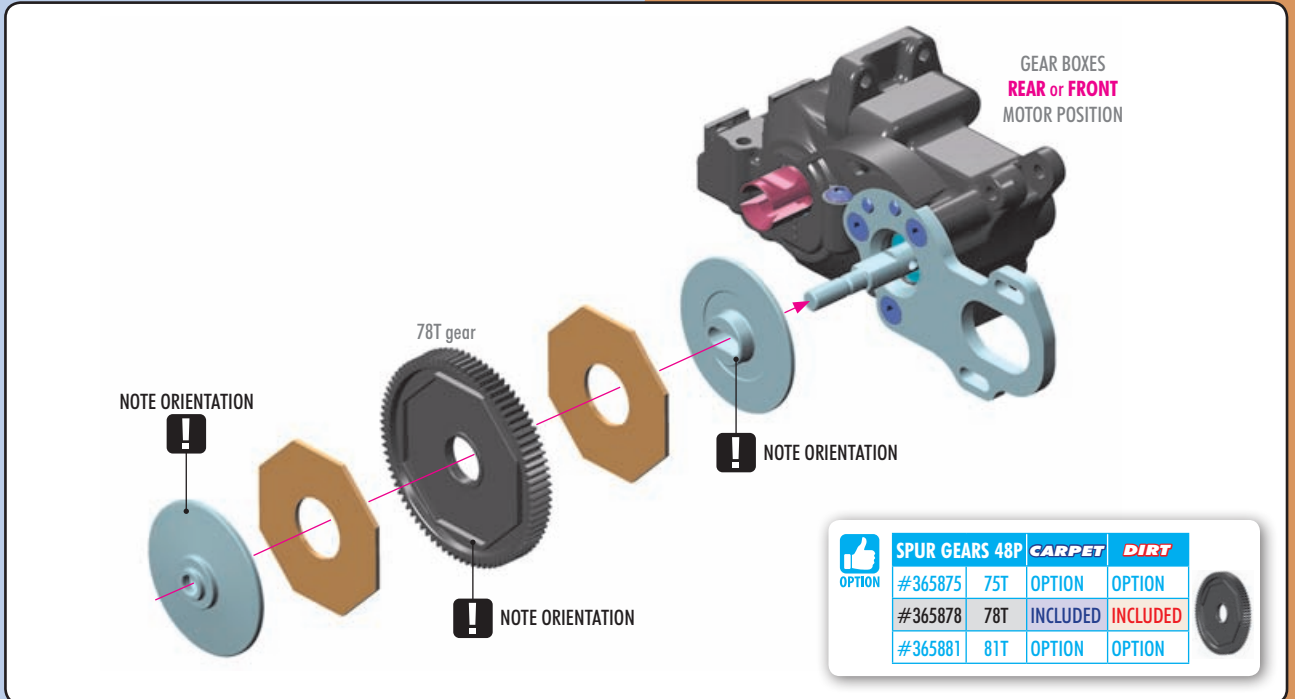
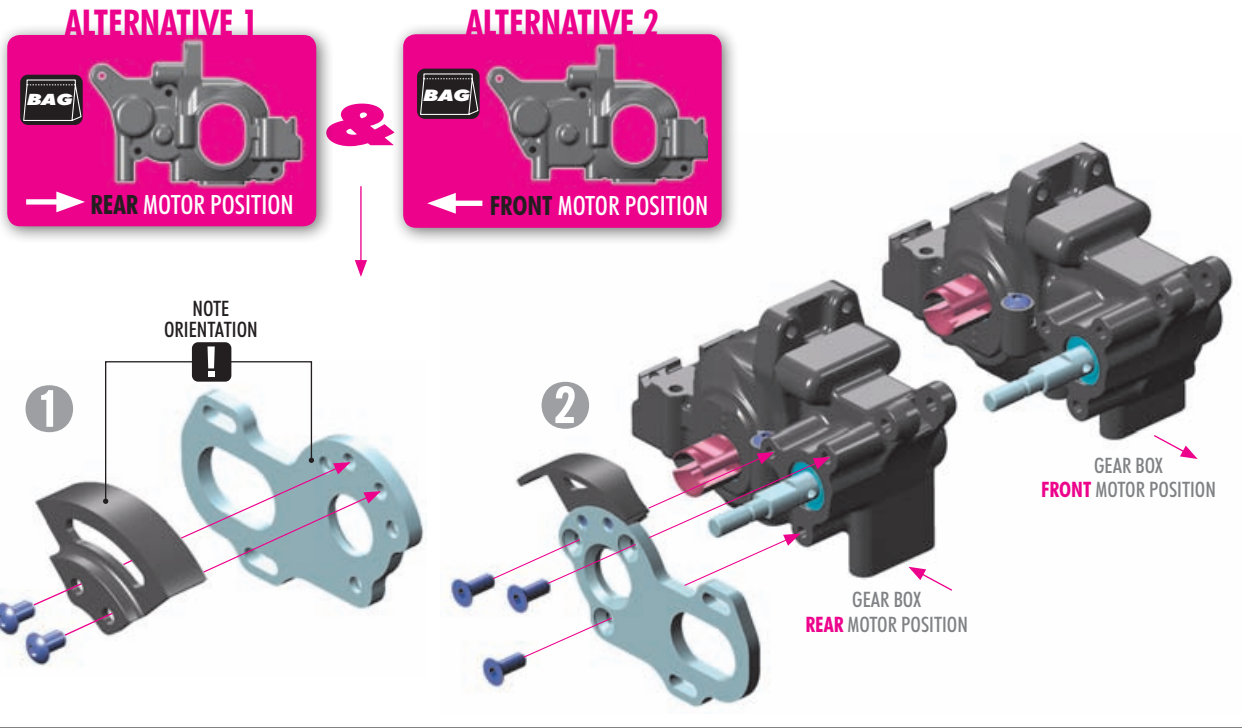

3. REAR SUSPENSION

CARPET **DIRT**

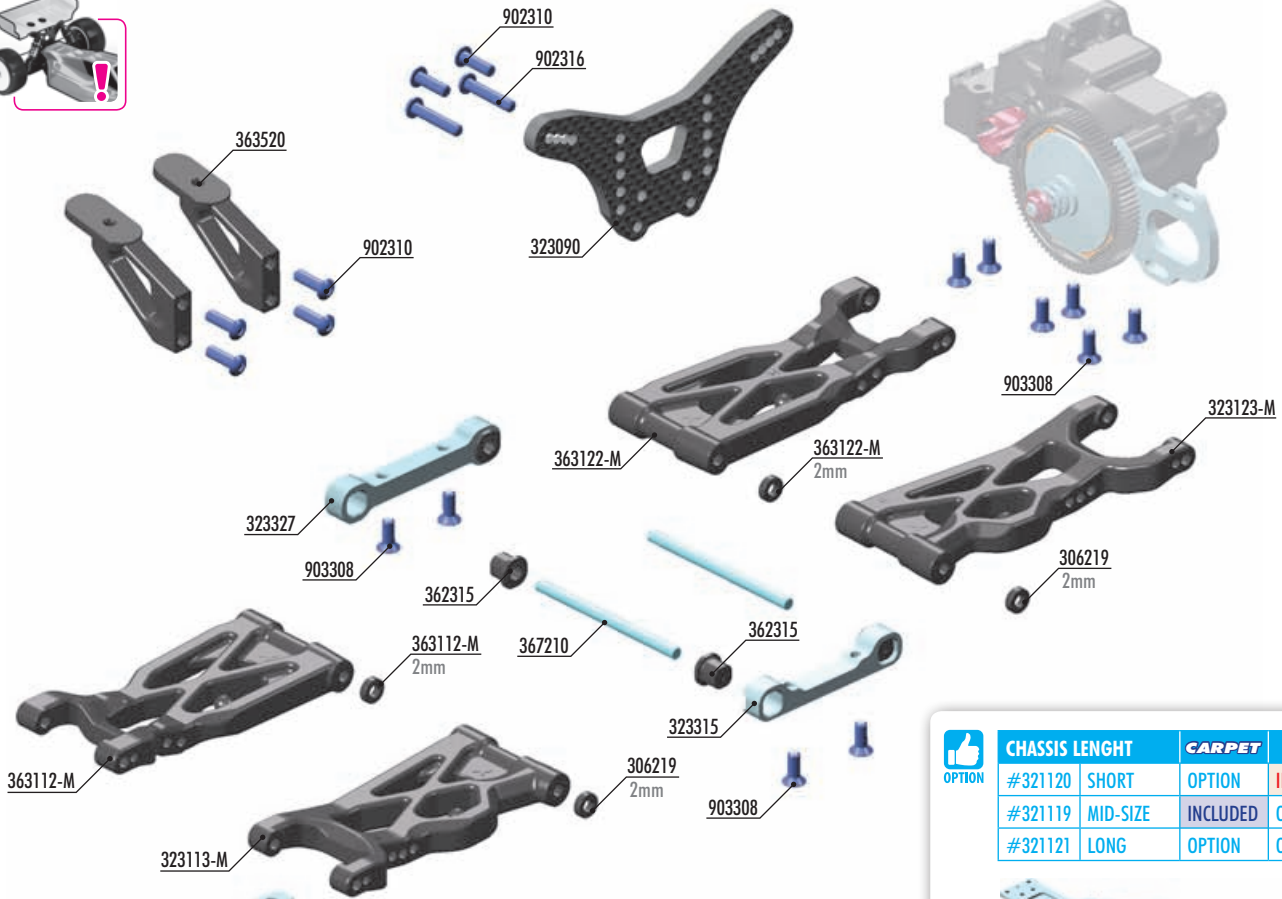

CHASSIS LENGTH		CARPET	DIRT
#321120	SHORT	OPTION	INCLUDED
#321119	MID-SIZE	INCLUDED	OPTION
#321121	LONG	OPTION	OPTION

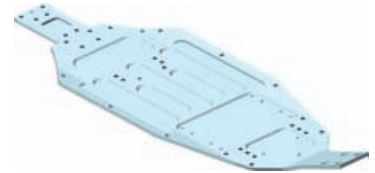

321119
CARPET
MID-SIZE

321120
DIRT
SHORT



#323326
ALU REAR LOWER SUSP.
HOLDER 1° - REAR



BAG

03

- 306219 COMPOSITE SET OF SHIMS (4)
- 323090 XB2 GRAPHITE SHOCK TOWER - REAR - LOWER
- 323113-M COMPOSITE DISENGAGED SUSPENSION ARM REAR LOWER RIGHT - MEDIUM
- 323123-M COMPOSITE DISENGAGED SUSPENSION ARM REAR LOWER LEFT - MEDIUM
- 323315 ALU REAR LOWER SUSPENSION HOLDER - WIDER - FRONT
- 323327 ALU REAR LOWER SUSPENSION HOLDER 3° - WIDER - REAR
- 362315 ECCENTRIC BUSHING SET (2)
- 363112-M COMPOSITE SUSPENSION ARM REAR LOWER RIGHT - MEDIUM
- 363122-M COMPOSITE SUSPENSION ARM REAR LOWER LEFT - MEDIUM
- 363520 REAR WING POST (2)
- 367210 REAR SUSPENSION PIVOT PIN (2)

- 902310 HEX SCREW SH M3x10 (10)
- 902316 HEX SCREW SH M3x16 (10)
- 903308 HEX SCREW SFH M3x8 (10)

CARPET

321119 XB2 ALU CHASSIS 1-PIECE - 2.5MM - MID-SIZE - SWISS 7075 T6

DIRT

321120 XB2 ALU CHASSIS 1-PIECE - 2.5MM - SHORT - SWISS 7075 T6

IO
2x From Rear Arm
SHIM 3x6x2

IO
2x 306219
SHIM 3x6x2

4x 903308
SFH M3x8

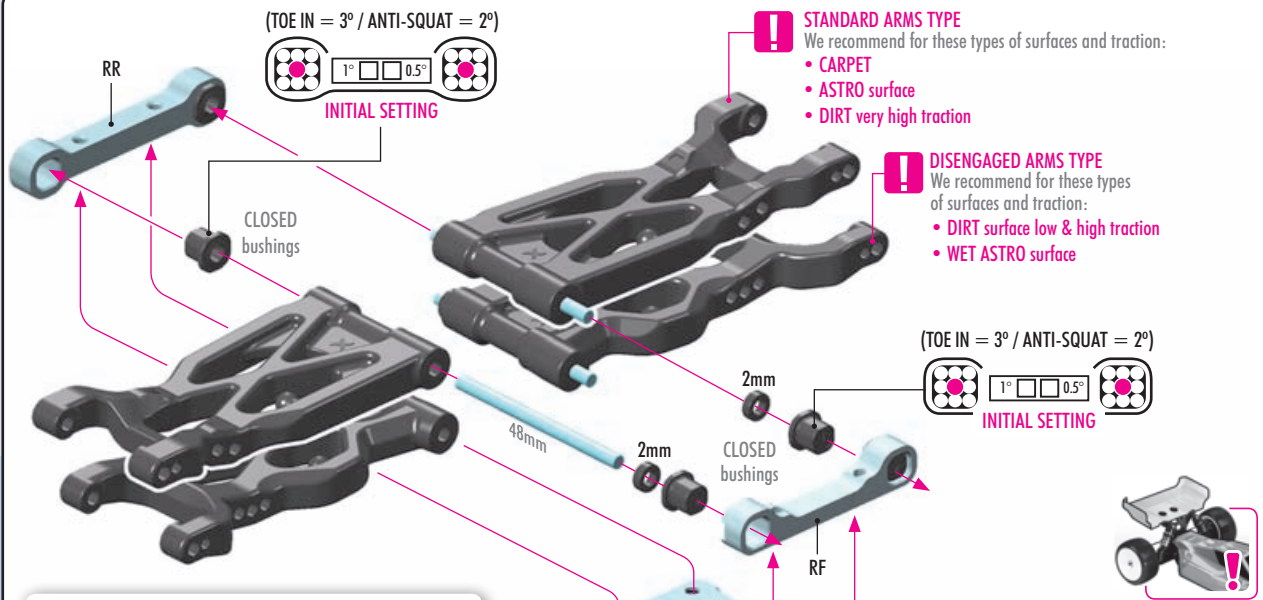

STANDARD ARMS TYPE
We recommend for these types of surfaces and traction:
• CARPET
• ASTRO surface
• DIRT very high traction

DISENGAGED ARMS TYPE
We recommend for these types of surfaces and traction:
• DIRT surface low & high traction
• WET ASTRO surface

(TOE IN = 3° / ANTI-SQUAT = 2°)
INITIAL SETTING

REAR ARMS DISENGAGED				DISENGAGED
#323113-M	R	MEDIUM	INCLUDED	
#323123-M	L	MEDIUM	INCLUDED	
#323113-H	R	HARD	OPTION	
#323123-H	L	HARD	OPTION	
#323113-G	R	GRAPHITE	OPTION	
#323123-G	L	GRAPHITE	OPTION	
REAR ARMS STANDARD				STANDARD
#363112-M	R	MEDIUM	INCLUDED	
#363122-M	L	MEDIUM	INCLUDED	
#363112-H	R	HARD	OPTION	
#363122-H	L	HARD	OPTION	
#363112-G	R	GRAPHITE	OPTION	
#363122-G	L	GRAPHITE	OPTION	

SUSPENSION ARMS vs GEAR BOXES CROSS REFERENCE TABLE

REAR MOTOR POSITION	FRONT MOTOR POSITION
DISENGAGED ✓	DISENGAGED ✓
STANDARD ✗ DO NOT USE	STANDARD ✓

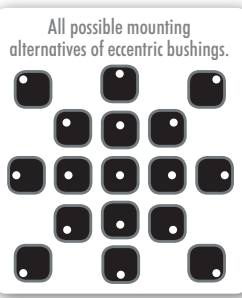

ECCENTRIC BUSHINGS HAVE TWO DIFFERENT OFFSETS FROM THE CENTER.

Middle position = 0.5° or 0.375mm from center.

Outer position = 1° or 0.75mm from center.

TIP Arm Reamer 3.0mm (HUDY #107643).

If the suspension arm DOES NOT move freely use a HUDY Arm Reamer to size the holes of the arms.

Check for free movement.

SET-UP BOOK
TOE-IN
ANTI-SQUAT
ROLL CENTER
TRACK-WIDTH

The XRAY rear alu lower suspension holders provide great range of adjustment for the rear suspension. Using different combinations of eccentric bushings, fine adjustment of rear anti-squat, rear toe-in, rear roll center, and rear track-width can be obtained. For more information about the influence of rear anti-squat, rear toe-in, rear roll center and rear track width on car handling, please refer to HUDY Set-up Book (#209100).

ANTI-SQUAT		(°)
RR	RF	
☐	☐	= 2.0°
☐	☐	= 3.0°
☐	☐	= 1.0°
☐	☐	= 3.0°
☐	☐	= 2.0°
☐	☐	= 4.0°
☐	☐	= 1.0°
☐	☐	= 2.0°
☐	☐	= 1.0°

ROLL CENTER		(mm)
RR	RF	
☐	☐	= +0.75mm
☐	☐	= 0mm
☐	☐	= -0.75mm

TRACK-WIDTH		(mm)
RR	RF	
☐	☐	= +1.5mm
☐	☐	= 0mm
☐	☐	= -1.5mm

The track-width is directly influenced by the size of the wheels and tires used.

The tables describe the amounts of adjustment using the center and outside positions of the eccentric bushings. The middle position eccentric bushings allow for finer adjustment increments.

ANTI-SQUAT Example:

0(RR) - 0 (RF) = 2.0°		= 2.0°
0(RR) - 0.5 (RF) = 2.5°		= 2.5°
0(RR) - 1 (RF) = 3.0°		= 3.0°

TOE-IN		(°)
RR	RF	
☐	☐	= 3°
☐	☐	= 4°
☐	☐	= 2°
☐	☐	= 2°
☐	☐	= 3°
☐	☐	= 1°
☐	☐	= 4°
☐	☐	= 5°
☐	☐	= 3°

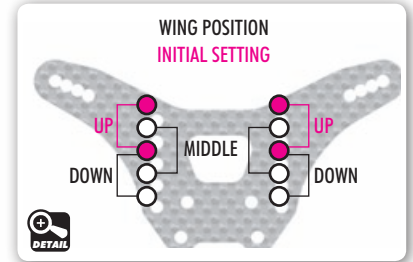
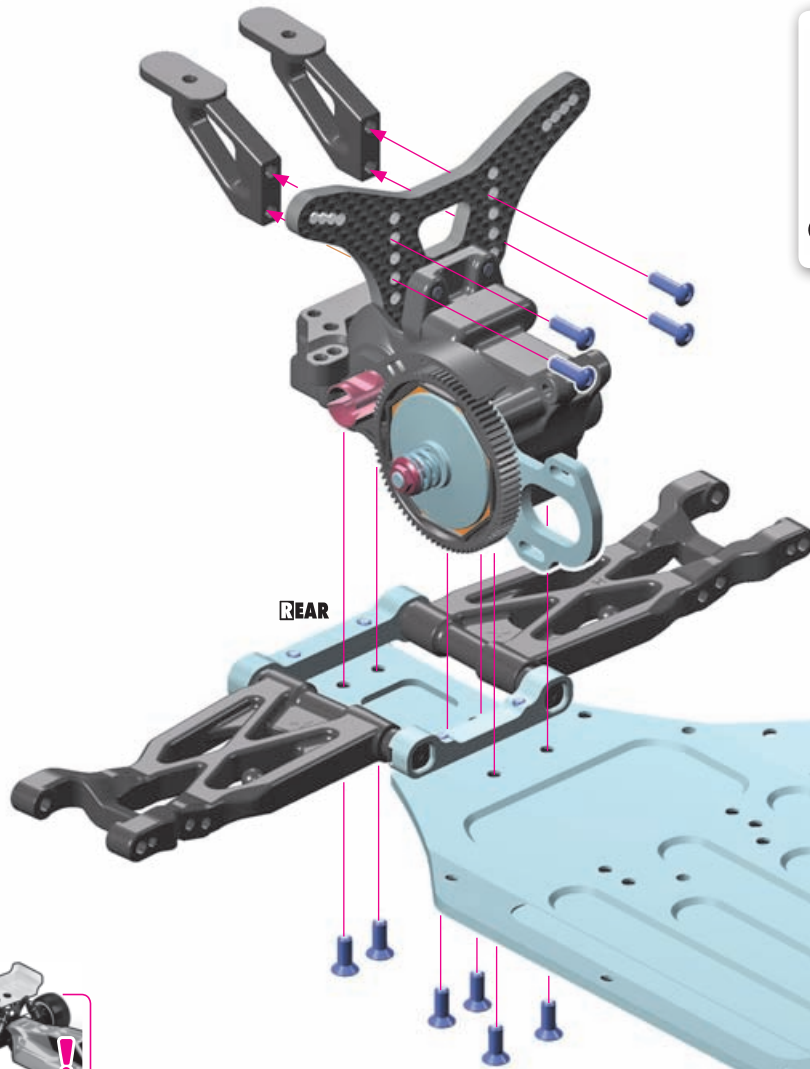
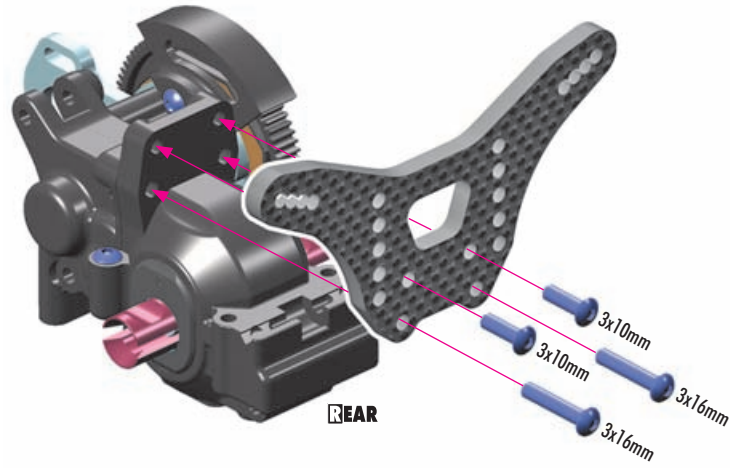

ANTI-ROLL BARS INCLUDED ONLY IN CARPET

BAG
3.1

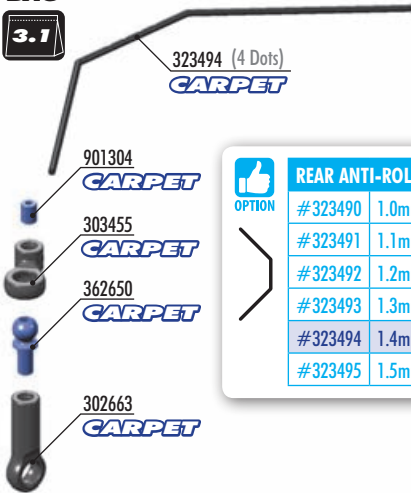

REAR ANTI-ROLL BARS			
#323490	1.0mm	OPTION	
#323491	1.1mm	OPTION	
#323492	1.2mm	OPTION	
#323493	1.3mm	OPTION	
#323494	1.4mm	INCLUDED	
#323495	1.5mm	OPTION	

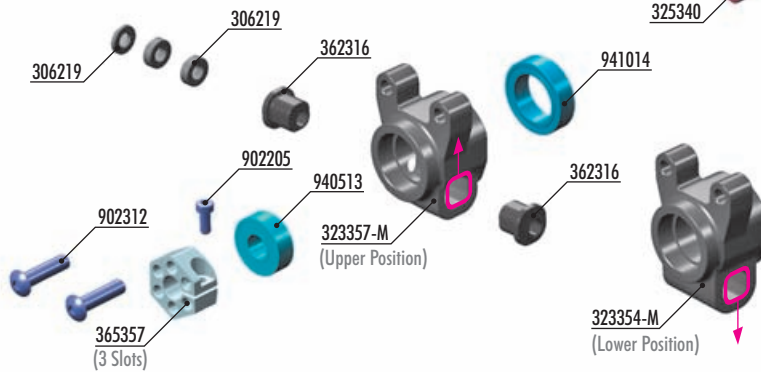
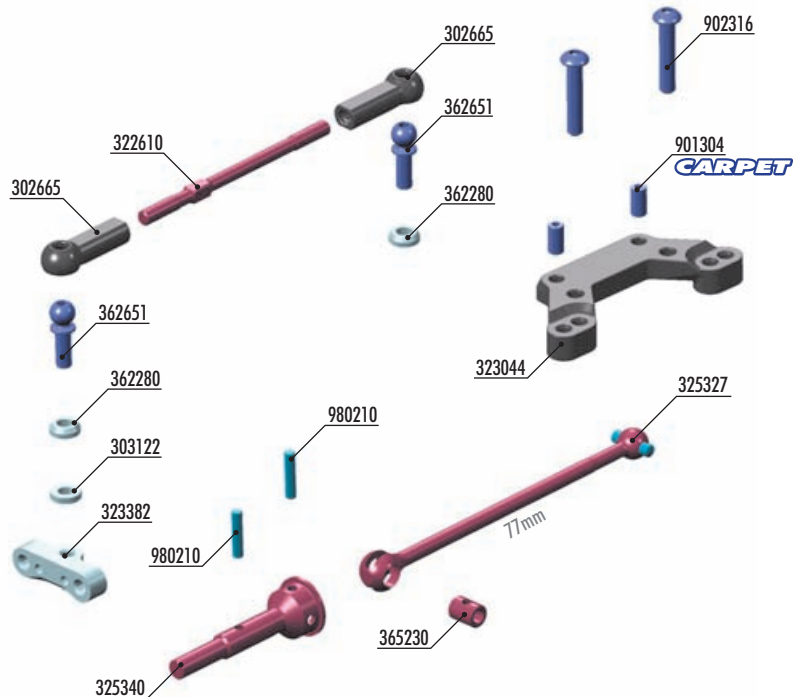

OPTION



#325341 REAR ADJ. DRIVE AXLE LB - HUDY SPRING STEEL™
#325390 ALU SHIM 10x12x2mm (2)

OPTION

HUDY TITAN BALL ENDS

#990006	6mm LONG	OPTION
#990008	8mm LONG	OPTION



OPTION

#305231
DRIVE SHAFT COUPLING HUDY
SPRING STEEL



OPTION

REAR UPRIGHTS

	Position	Position	
		UPPER	LOWER
#323354-M	MEDIUM	UPPER	INCLUDED
#323357-M	MEDIUM	LOWER	INCLUDED
#323354-H	HARD	UPPER	OPTION
#323354-G	GRAPHITE	UPPER	OPTION
#323357-G	GRAPHITE	LOWER	OPTION
#323355	ALU HIGH	UPPER	OPTION
#323356	ALU LOW	LOWER	OPTION



OPTION

WHEEL HUBS 12MM

#365360	+4.5mm - 6 SLOTS	OPTION
#365359	+3.75mm - 5 SLOTS	OPTION
#365358	+3.0mm - 4 SLOTS	OPTION
#365357	+2.25mm - 3 SLOTS	INCLUDED
#365356	+1.5mm - 2 SLOTS	OPTION
#365355	+0.75mm - 1 SLOT	OPTION
#365353	0mm - 0 SLOTS	OPTION
#365354	-0.75mm - Lightw.	OPTION
#365361	-1.25mm - Lightw.	OPTION



OPTIONAL HEX HUB EFFECTS

Different offset hex hubs are used to increase or decrease the track-width.

LESS OFFSET

Rear - more traction
Front - more steering

MORE OFFSET

Rear - less traction
Front - less steering

BAG

03

- 302665 COMPOSITE BALL JOINT 4.9mm - CLOSED WITH HOLE (4)
- 303122 ALU SHIM 3x6x1.0mm (10)
- 306219 COMPOSITE SET OF SHIMS (4)
- 322610 ADJUSTABLE TURNBUCKLE 55mm M3 L/R - HUDY SPRING STEEL™ (2)
- 323044 COMPOSITE REAR ROLL CENTER HOLDER FOR ANTI-ROLL BAR
- 323354-M COMPOSITE UPRIGHT REAR - UPPER POSITION - MEDIUM
- 323357-M COMPOSITE UPRIGHT REAR - LOWER POSITION - MEDIUM
- 323382 ALU REAR HUB PLATE FOR MULTI ADJ. UPRIGHT - 1-HOLE - SWISS 7075 T6
- 325327 REAR DRIVE SHAFT 77mm WITH 2.5mm PIN - HUDY SPRING STEEL™
- 325340 REAR DRIVE AXLE LB - HUDY SPRING STEEL™

- 327210 SUSPENSION PIVOT PIN (2)
- 362280 ALU CONICAL SHIM 3x6x2.0mm (10)
- 362316 ECCENTRIC BUSHING SET - OPEN (2)
- 362651 BALL ENDS 4.9mm WITH THREAD 8mm (2)
- 365230 DRIVE SHAFT COUPLING - HUDY SPRING STEEL™
- 365357 ALU WHEEL HUB 12mm - 3 SLOTS - OFFSET "+2.25mm" (2)

- 902205 HEX SCREW SH M2x5 (10)
- 902254 HEX SCREW SH M2.5x4 (10)
- 902312 HEX SCREW SH M3x12 (10)
- 902316 HEX SCREW SH M3x16 (10)
- 940513 BALL-BEARING 5x12x4 RUBBER SEALED - GREASE (2)
- 941014 BALL-BEARING 10x15x4 RUBBER SEALED - GREASE (2)
- 980210 PIN 2x9.8 (10)

BAG

3.1

CARPET

- 302663 COMPOSITE BALL JOINT 4.9mm - OPEN - V2 (8)
- 303455 COMPOSITE ANTI-ROLL BAR BALL JOINT 4.9mm (4)
- 323494 XB2 ANTI-ROLL BAR REAR - SHORT - 1.4mm
- 362650 BALL ENDS 4.9mm WITH THREAD 6mm (2)
- 901304 HEX SCREW SB M3x4 (10)

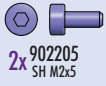

2x 902205 SH M2x5

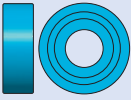

2x 940513 BB 5x12x4



2x 941014 BB 10x15x4



4x 980210 P 2x10

2x L=R

UPRIGHT ALTERNATIVE 2

We recommend for these types of surfaces and traction:

- DIRT low & high traction
- Wet ASTRO

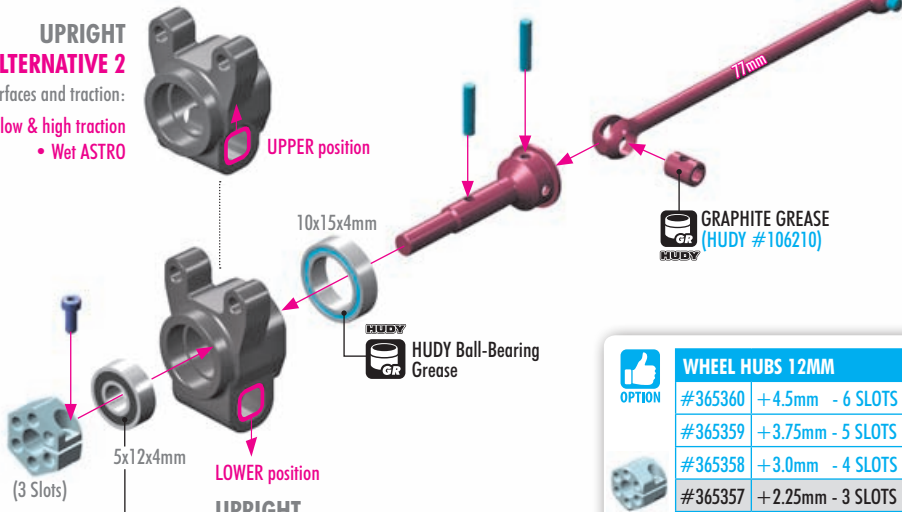

Bearing with BLACK rubber covers

UPRIGHT ALTERNATIVE 1

We recommend for these types of surfaces and traction:

- CARPET
- Dry ASTRO
- DIRT very high traction

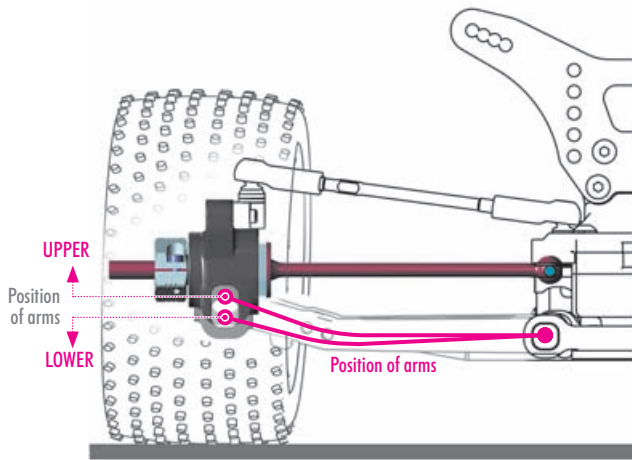

OPTION



#325341 REAR ADJ. DRIVE AXLE LB - HUDY SPRING STEEL™
#325390 ALU SHIM 10x12x2mm (2)

OPTION

WHEEL HUBS 12MM

#365360	+4.5mm - 6 SLOTS	OPTION
#365359	+3.75mm - 5 SLOTS	OPTION
#365358	+3.0mm - 4 SLOTS	OPTION
#365357	+2.25mm - 3 SLOTS	INCLUDED
#365356	+1.5mm - 2 SLOTS	OPTION
#365355	+0.75mm - 1 SLOT	OPTION
#365353	0mm - 0 SLOTS	OPTION
#365354	-0.75mm - Lightw.	OPTION
#365361	-1.25mm - Lightw.	OPTION

OPTIONAL HEX HUB EFFECTS

Different offset hex hubs are used to increase or decrease the track-width.

LESS OFFSET

Rear - more traction
Front - more steering

MORE OFFSET

Rear - less traction
Front - less steering

OPTION

XRAY BALL-BEARINGS

#940512	5x12x4	OIL	OPTION
#941015	10x15x4	OIL	OPTION
#940513	5x12x4	GREASE	INCLUDED
#941014	10x15x4	GREASE	INCLUDED

OPTION

REAR UPRIGHTS

		Position	
#323354-M	MEDIUM	UPPER	INCLUDED
#323357-M	MEDIUM	LOWER	INCLUDED
#323354-H	HARD	UPPER	OPTION
#323354-G	GRAPHITE	UPPER	OPTION
#323357-G	GRAPHITE	LOWER	OPTION
#323355	ALU HIGH	UPPER	OPTION
#323356	ALU LOW	LOWER	OPTION

2x L=R



4x 902312 SH M3x12

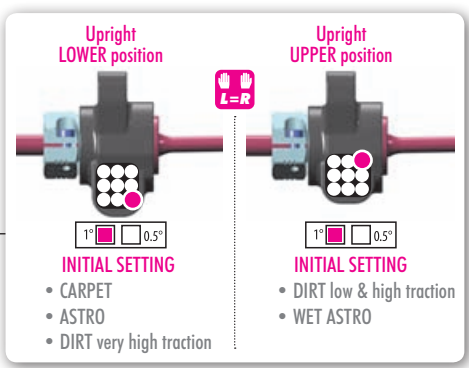
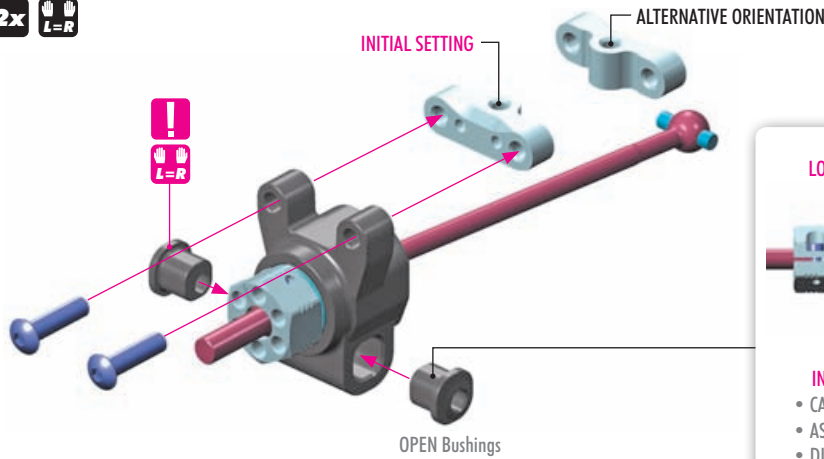

INITIAL SETTING
• CARPET
• ASTRO
• DIRT very high traction

INITIAL SETTING
• DIRT low & high traction
• WET ASTRO

REAR ANTI-ROLL BAR CARPET

Step only for Carpet edition.

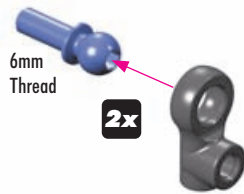

TIP Install the pivot balls with Professional Multi Tool (HUDY #183011).

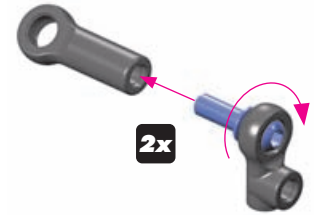

CARPET

Step only for Carpet edition.



HUDY TITAN BALL ENDS

#990006 6mm Thread OPTION



2x 901304
SB M3x4

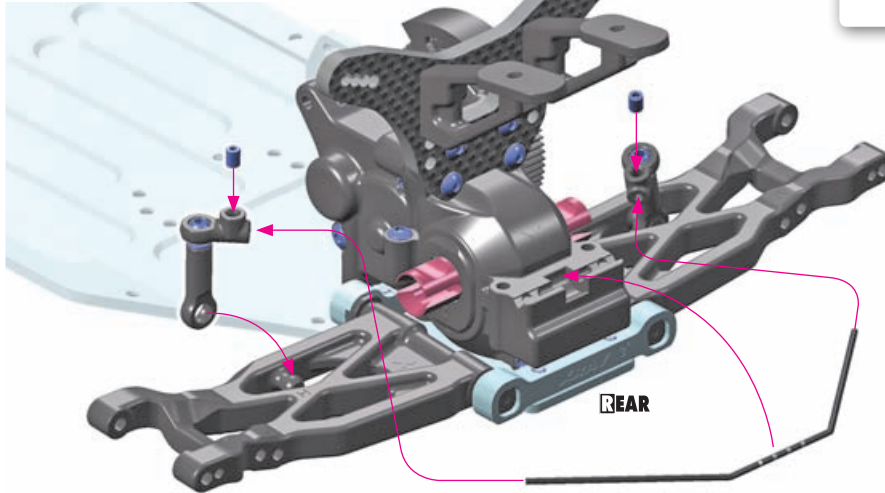

REAR ANTI-ROLL BARS

#323490	1.0mm	OPTION
#323491	1.1mm	OPTION
#323492	1.2mm	OPTION
#323493	1.3mm	OPTION
#323494	1.4mm	INCLUDED
#323495	1.5mm	OPTION

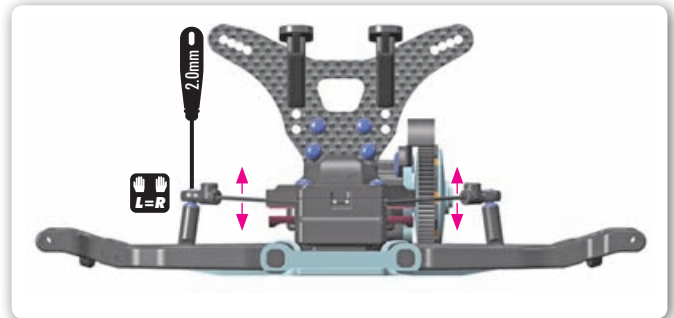
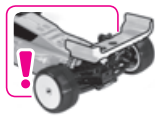

2x 901304
SB M3x4

CARPET

Assembly with anti-roll bar.

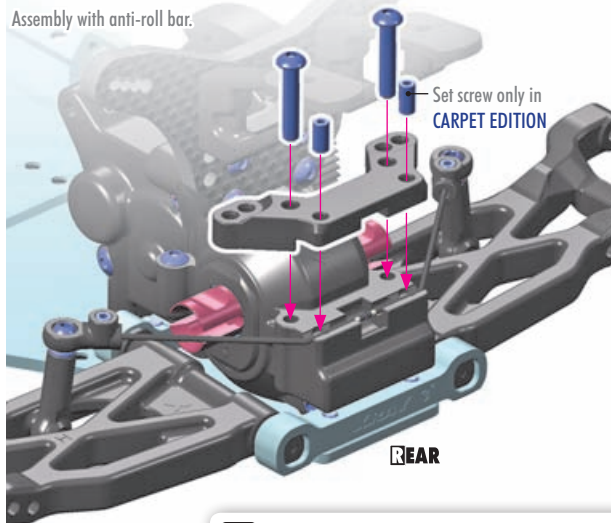

DIRT

Assembly without anti-roll bar.

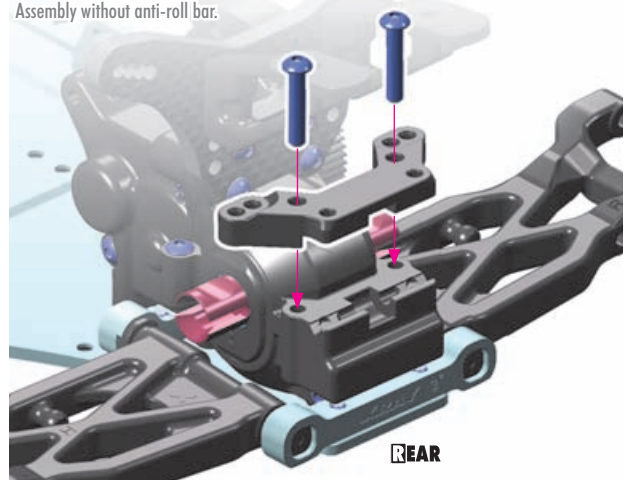

902316
SH M3x16



Check for free movement.

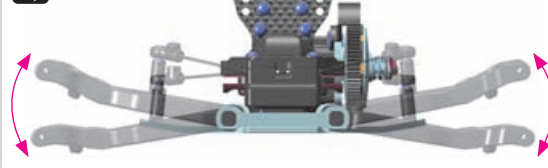

REAR ROLL CENTER HOLDERS

#323044	HARD	INCLUDED
#323044-G	GRAPHITE	OPTION
#323043	ALU	OPTION



- IO**
2x 306219 SHIM 3x6x1
- IO**
2/4x 306219 SHIM 3x6x2
- 4x** 902254 SH M2.5x4

ALTERNATIVE 1
STANDARD ARMS TYPE

2mm
1mm
35mm

TIGHTEN GENTLY

STANDARD ARMS TYPE

ALTERNATIVE 2
DISENGAGED ARMS TYPE

2mm
2mm
1mm
35mm

TIGHTEN GENTLY

DISENGAGED ARMS TYPE

2x **L=R**

LEFT THREAD
RIGHT THREAD
8mm THREAD
8mm THREAD

DIRT 41.2mm
CARPET 40.5mm

TIP Install the pivot balls with Professional Multi Tool (HUDY #183011).

HUDY TITAN BALL ENDS
#990008 8mm Thread

- 2x** 303122 SHIM 3x6x1
- 4x** 362280 CON. SHIM 3x6x2

2x **L=R**

8mm THREAD
2mm CONICAL SHIM
1mm SHIM
8mm THREAD
2mm CONICAL SHIM

INITIAL SETTING

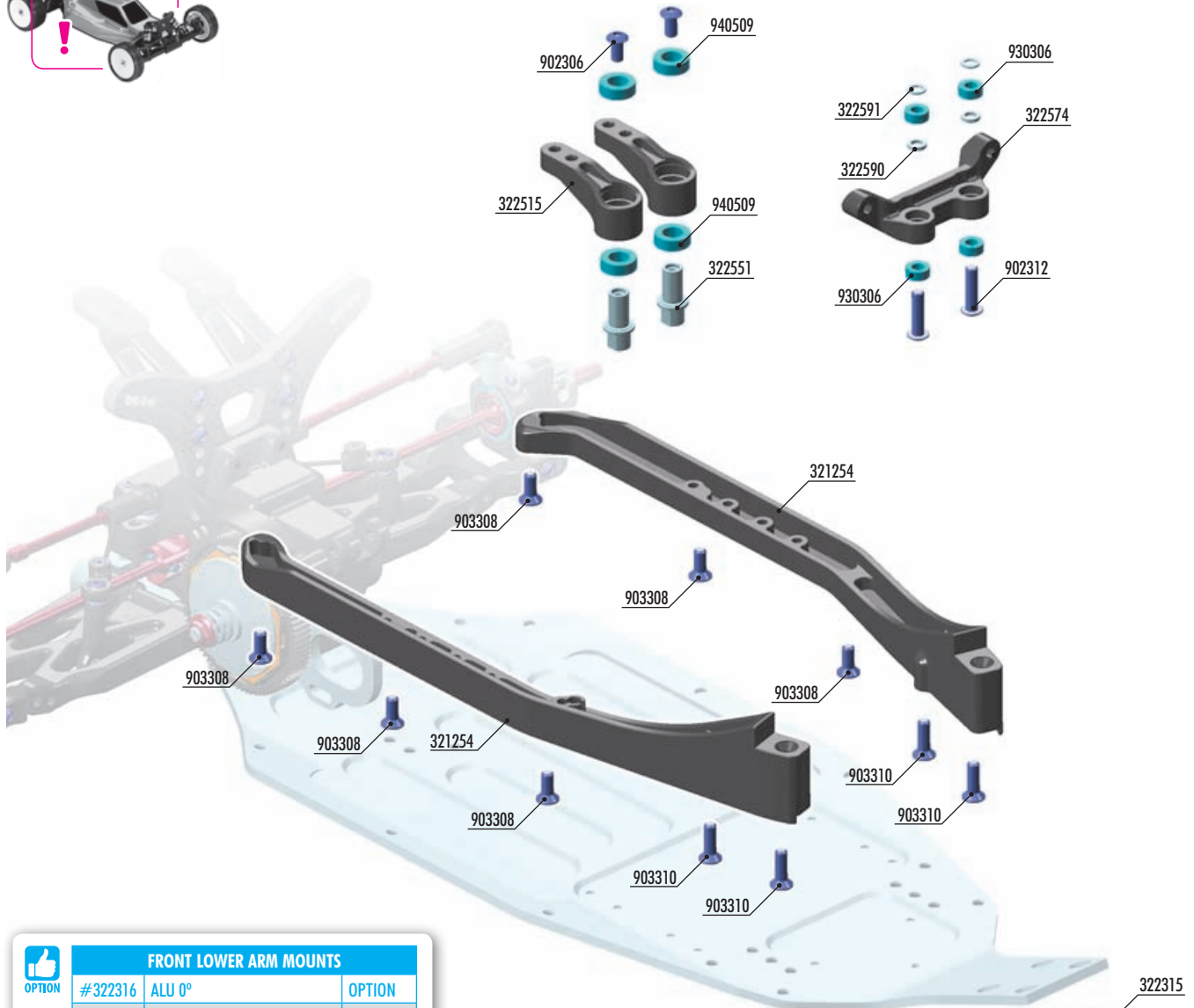

FRONT LOWER ARM MOUNTS

#322316	ALU 0°	OPTION
#322315	COMPOSITE 0°	INCLUDED
#322312	BRASS 0°	OPTION
#322317	ALU +3°/-3°	OPTION
#321211	SUSP. HOLDER BRACE +3°/-3°	OPTION



ARM MOUNTS - WEIGHT			
Composite	BRASS	ALU	ALU + Tungsten
6g	46g	13.5g	23.5g

COMPOSITE - Generates more traction in front.
 ALU - Makes car more stable.
 BRASS - Adds more weight in front, less weight transfer.



The alu arm mounts can be used with optional weight:
 #293085 HUDY Pure Tungsten Weight - 10g.



STEERING ARMS

#322515	HARD	INCLUDED
#322516	ALU	OPTION



STEERING PLATES

#322574	HARD	INCLUDED
#322575	ALU	OPTION



BAG

04

- 321254 COMPOSITE ELEVATED CHASSIS SIDE BRACES L+R
- 322315 COMPOSITE FRONT LOWER ARM MOUNT FOR 1-PIECE CHASSIS
- 322515 COMPOSITE STEERING ARM FOR 1-PIECE CHASSIS (2)
- 322551 ALU SERVO SAVER PIVOT SHAFT 15.3mm - SWISS 7075 T6 (2)
- 322574 COMPOSITE STEERING PLATE FOR 1-PIECE CHASSIS
- 322590 ALU SHIM 3x4.7x1.0mm (10)
- 322591 ALU SHIM 3x4.7x0.5mm (10)

- 902306 HEX SCREW SH M3x6 (10)
- 902308 HEX SCREW SH M3x8 (10)
- 902312 HEX SCREW SH M3x12 (10)
- 903308 HEX SCREW SFH M3x8 (10)
- 903310 HEX SCREW SFH M3x10 (10)
- 930306 BALL-BEARING 3x6x2.5mm STEEL SEALED - OIL (2)
- 940509 BALL-BEARING 5x9x3mm RUBBER SEALED - OIL (2)

4. FRONT ASSEMBLY

CARPET DIRT



6x 903308
SFH M3x8



4x 903310
SFH M3x10

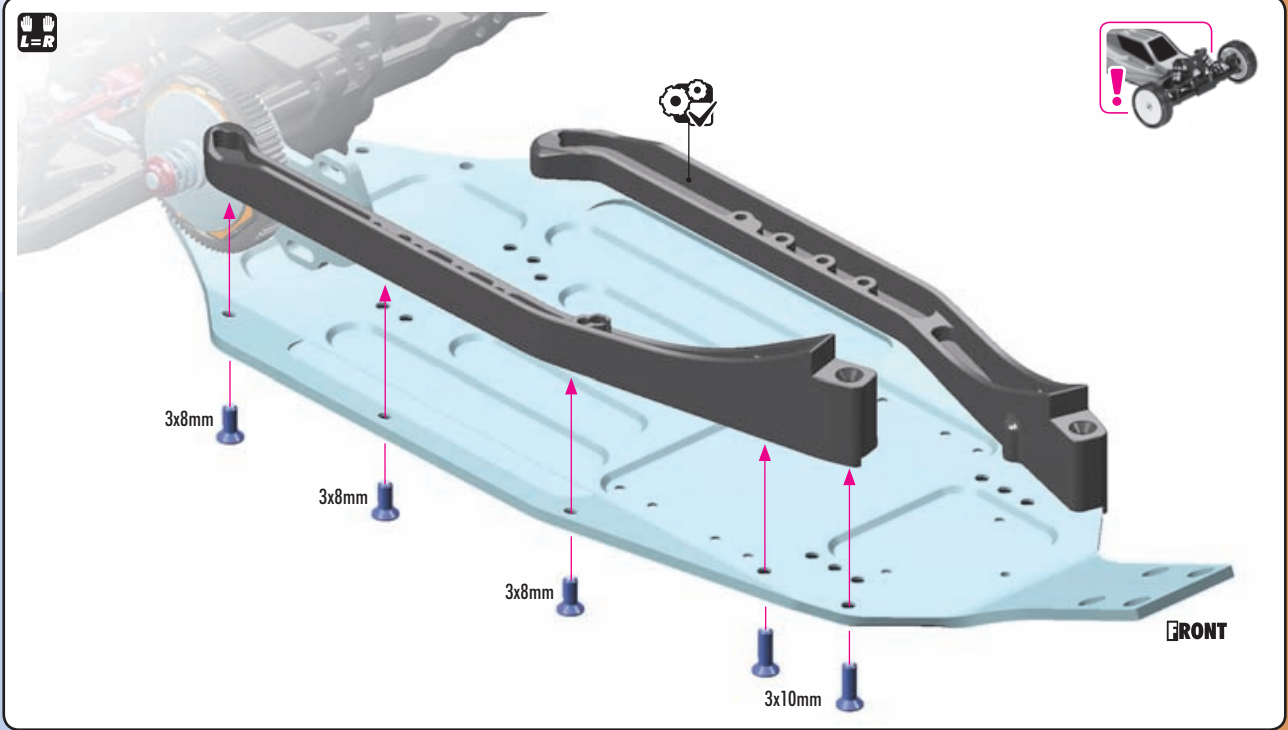

2x 322590
SHIM 3x4.7x1



4x 930306
BB 3x6x2.5

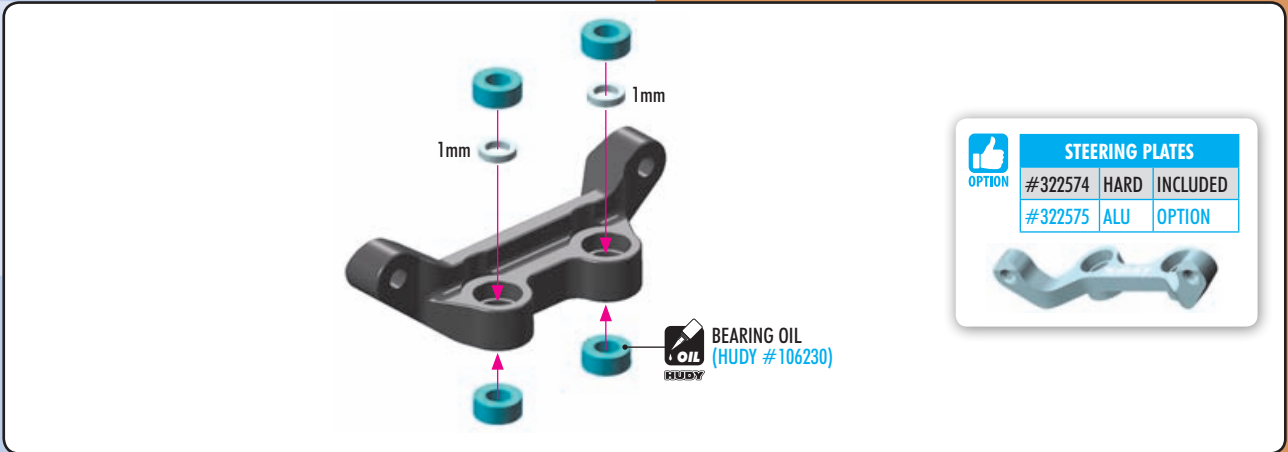

2x 322591
SHIM 3x4.7x0.5

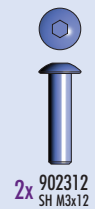

2x 902312
SH M3x12

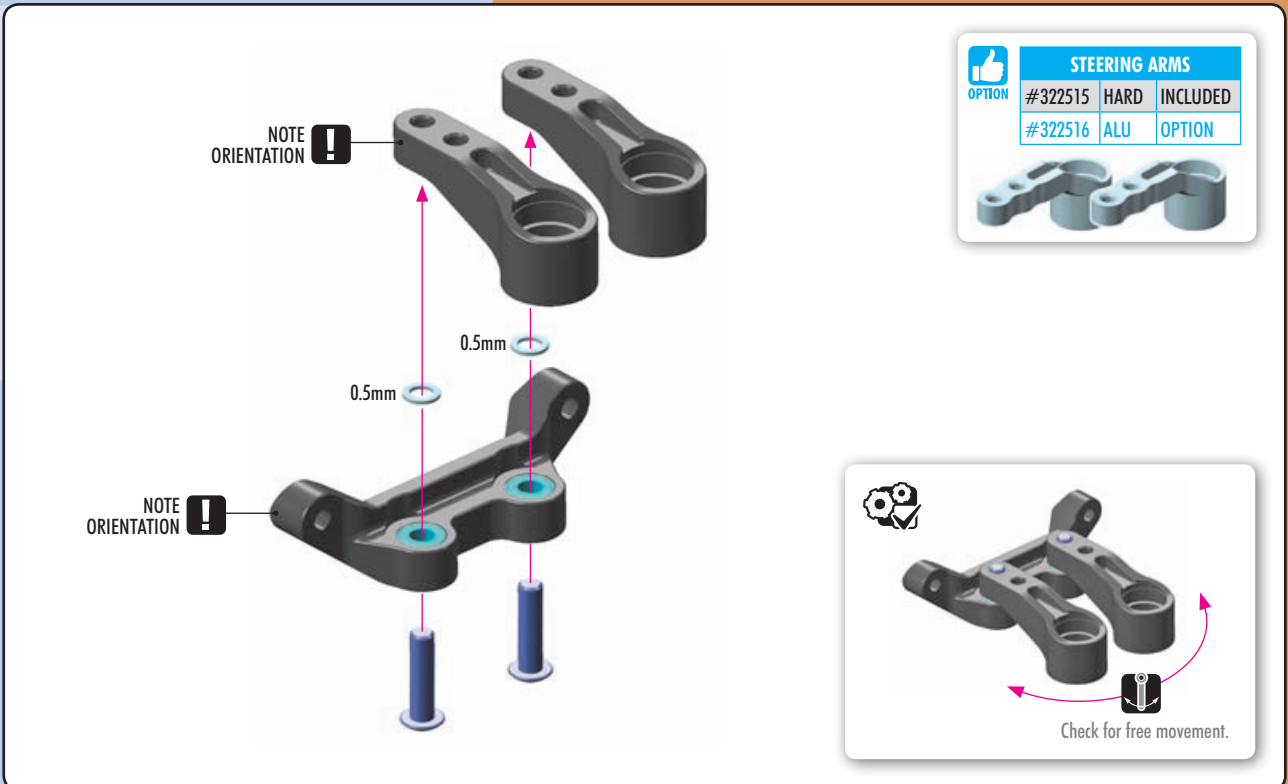

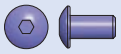

2x 902306
SH M3x6



4x 940509
BB 5x9x3

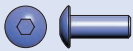
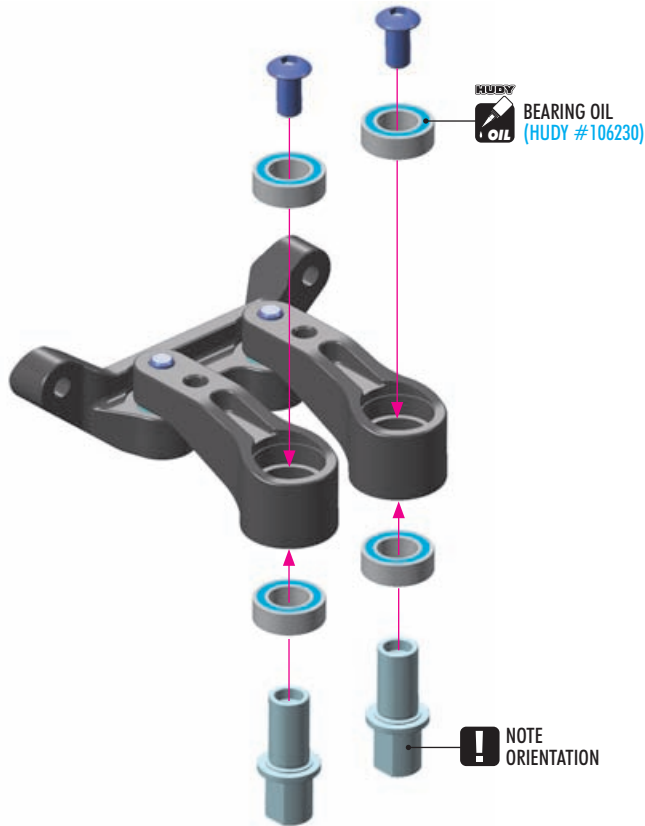

2x 902308
SH M3x8

The alu arm mounts can be used with optional weight:

OPTION #293085 HUDY Pure Tungsten Weight - 10g.

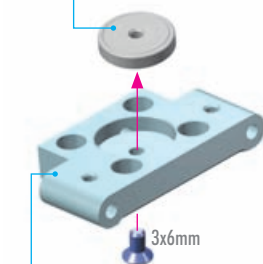

OPTION ALU FRONT LOWER ARM MOUNTS



FRONT LOWER ARM MOUNTS

#322316	ALU 0°	OPTION
#322315	COMPOSITE 0°	INCLUDED
#322312	BRASS 0°	OPTION
#322317	ALU +3°/-3°	OPTION
#321211	SUSP. HOLDER BRACE +3°/-3°	OPTION



ARM MOUNTS - WEIGHT

Composite	BRASS	ALU	ALU + Tungsten
6g	46g	13.5g	23.5g

COMPOSITE - Generates more traction in front.

ALU - Makes car more stable.

BRASS - Adds more weight in front, less weight transfer.



The alu arm mounts can be used with optional #293085 HUDY Pure Tungsten Weight - 10g.





XRAY BALL-BEARINGS

#940510	5x10x4	OIL	OPTION
#359050	5x10x4	GREASE	INCLUDED



STEERING BLOCKS

#322250-M	MEDIUM	INCLUDED
#322250-H	HARD	OPTION
#322250-G	GRAPHITE	OPTION



HUDY TITAN BALL ENDS

#990008	8mm Thread	OPTION
#990010	10mm Thread	OPTION



FRONT LSM SUSPENSION ARMS

#322113-M	RIGHT	MEDIUM	INCLUDED
#322123-M	LEFT	MEDIUM	INCLUDED
#322113-H	RIGHT	HARD	OPTION
#322123-H	LEFT	HARD	OPTION
#322113-G	RIGHT	GRAPHITE	OPTION
#322123-G	LEFT	GRAPHITE	OPTION



FRONT ROLL CENTER HOLDERS

#322045	HARD	INCLUDED
#322046	ALU	OPTION



STEERING BLOCK EXTENSION

#322294	1 DOT	OPTION
#322295	2 DOTS	INCLUDED
#322296	3 DOTS	OPTION



C-HUBS

#322210-M	RIGHT	MEDIUM	INCLUDED
#322210-H	RIGHT	HARD	OPTION
#322210-G	RIGHT	GRAPHITE	OPTION
#322220-M	LEFT	MEDIUM	INCLUDED
#322220-H	LEFT	HARD	OPTION
#322220-G	LEFT	GRAPHITE	OPTION



WHEEL HEX HUBS 12MM

#365360	+4.5mm	6 SLOTS	OPTION
#365359	+3.75mm	5 SLOTS	OPTION
#365358	+3.0mm	4 SLOTS	OPTION
#365357	+2.25mm	3 SLOTS	OPTION
#365356	+1.5mm	2 SLOTS	OPTION
#365355	+0.75mm	1 SLOT	OPTION
#365353	0mm	0 SLOTS	INCLUDED
#365354	-0.75mm	Lightw.	OPTION
#365361	-1.25mm	Lightw.	OPTION

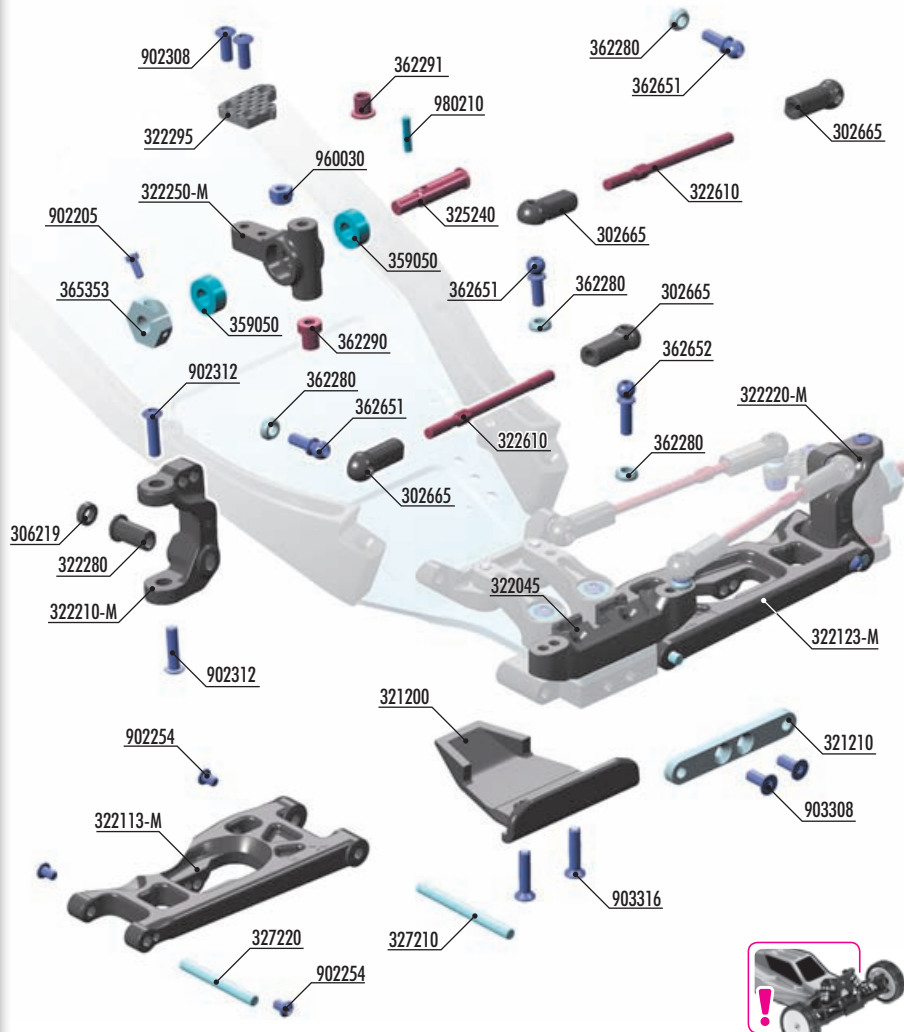

#320903 XB2 ALU STEERING BLOCKS & C-HUBS - SET - V2

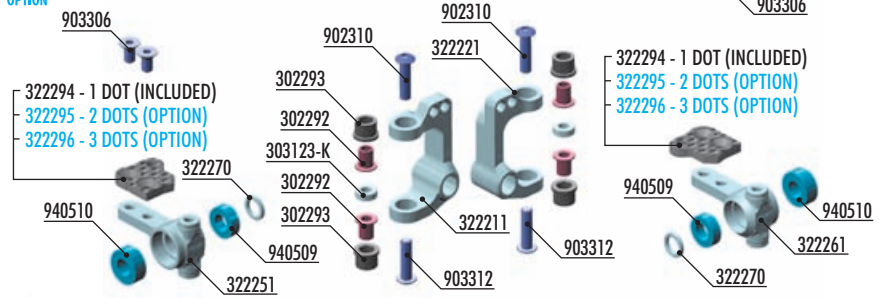

1mm WHEELBASE SHIM *When using optional aluminum C-hub add extra +1mm shim for wheelbase adjustment.

BAG



- 302665 COMPOSITE BALL JOINT 4.9mm - CLOSED WITH HOLE (4)
- 306219 COMPOSITE SET OF SERVO SHIMS (4)
- 321200 COMPOSITE FRONT BUMPER
- 321210 ALU SUSPENSION HOLDER BRACE - SWISS 7075 T6 (3mm)
- 322045 COMPOSITE FRONT ROLL-CENTER HOLDER FOR BRIDGE UPPER DECK
- 322113-M SUSP. ARM FRONT - LOW SHOCK MOUNTING - LOWER RIGHT - MEDIUM
- 322123-M SUSP. ARM FRONT - LOW SHOCK MOUNTING - LOWER LEFT - MEDIUM
- 322210-M COMPOSITE C-HUB 0° DEG. RIGHT - MEDIUM
- 322220-M COMPOSITE C-HUB 0° DEG. LEFT - MEDIUM
- 322250-M COMPOSITE STEERING BLOCK - MEDIUM
- 322280 COMPOSITE CASTER ECCENTRIC BUSHING (2+2+2)
- 322295 GRAPHITE EXTENSION FOR STEERING BLOCK - 2 DOTS (2)
- 322610 ADJUSTABLE TURNBUCKLE 55mm M3 L/R - HUDY SPRING STEEL™ (2)
- 325240 FRONT DRIVE AXLE - HUDY SPRING STEEL™
- 327210 FRONT SUSPENSION PIVOT PIN (2)
- 327220 FRONT ARM PIVOT PIN (2)

- 362280 ALU CONICAL SHIM 3x6x2.0mm (10)
- 362290 STEEL STEERING BUSHING - SHORT (2)
- 362291 STEEL STEERING BUSHING - LONG (2)
- 362651 BALL ENDS 4.9mm WITH THREAD 8mm (2)
- 362652 BALL ENDS 4.9mm WITH THREAD 10mm (2)
- 365353 ALU WHEEL HUB 12mm (2)
- 359050 BALL-BEARING 5x10x4 STEEL SEALED - GREASE (2)
- 902205 HEX SCREW SH M2x5 (10)
- 902254 HEX SCREW SH M2.5x4 (10)
- 902308 HEX SCREW SH M3x8 (10)
- 902312 HEX SCREW SH M3x12 (10)
- 903308 HEX SCREW SFH M3x8 (10)
- 903316 HEX SCREW SFH M3x16 (10)
- 960030 NUT M3 (10)
- 980210 PIN 2x9.8 (10)

5. FRONT SUSPENSION

CARPET DIRT

4x 902254
SH M2.5x4

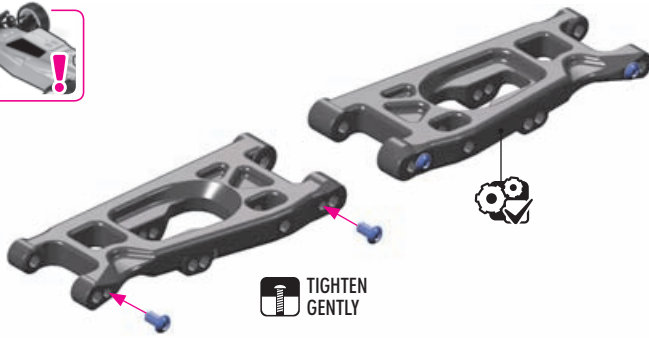

TIGHTEN GENTLY



FRONT LSM SUSPENSION ARMS

Part #	Side	Material	Status
#322113-M	RIGHT	MEDIUM	INCLUDED
#322123-M	LEFT	MEDIUM	INCLUDED
#322113-H	RIGHT	HARD	OPTION
#322123-H	LEFT	HARD	OPTION
#322113-G	RIGHT	GRAPHITE	OPTION
#322123-G	LEFT	GRAPHITE	OPTION



2x 903308
SFH M3x8

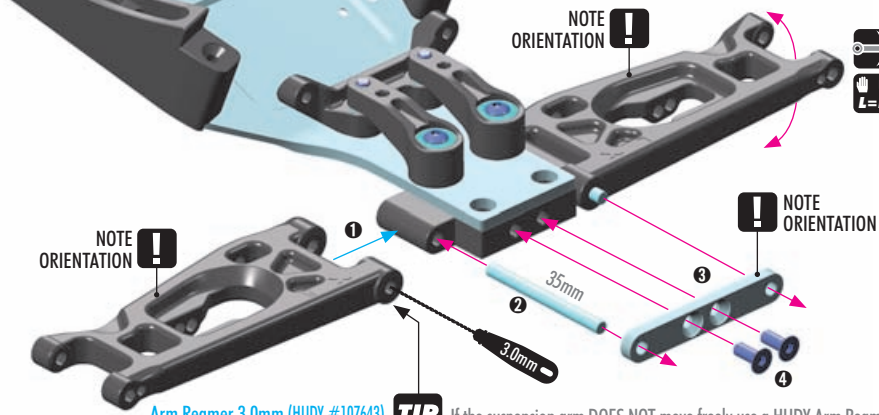

Arm Reamer 3.0mm (HUDY #107643)

TIP If the suspension arm DOES NOT move freely use a HUDY Arm Reamer to size the holes of the arms.

2x 903316
SFH M3x16

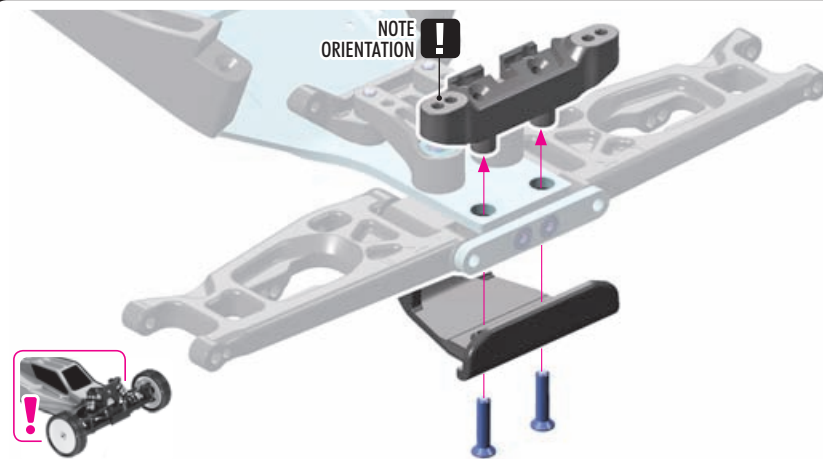

#322046
ALU FRONT ROLL-CENTER HOLDER FOR BRIDGE UPPER DECK



4x 902308
SH M3x8

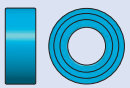

4x 940510
BB 5x10x4

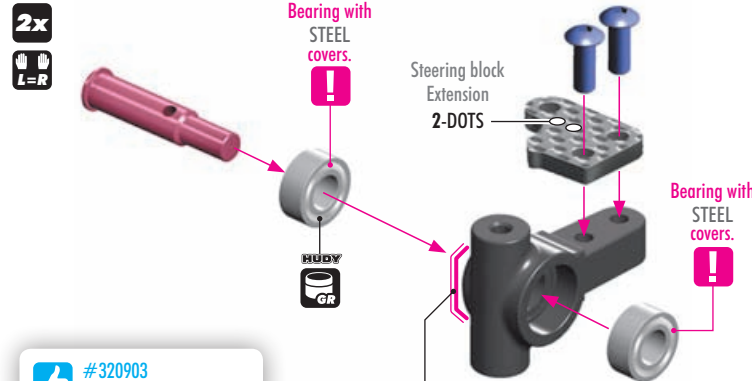

STEERING BLOCK EXTENSION

Part #	Configuration	Status
#322294	1 DOT	OPTION
#322295	2 DOTS	INCLUDED
#322296	3 DOTS	OPTION

Maximum steering 1 Dot 2 Dots 3 Dots Reduced steering

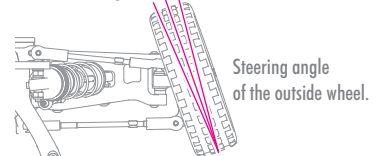

#320903
ALU STEERING BLOCKS & C-HUBS - SET - V2

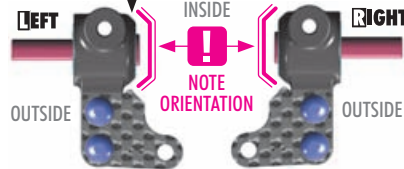

STEERING BLOCKS

Part #	Material	Status
#322250-M	MEDIUM	INCLUDED
#322250-H	HARD	OPTION
#322250-G	GRAPHITE	OPTION

MEDIUM - More steering on low traction.
HARD - More free in corner on high traction.
GRAPHITE - Less stopping in corner on high traction.

- 2x 902205 SH M2x5
- 2x 981210 P 2x10

2x L=R

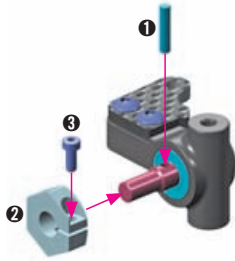

OPTION

WHEEL HEX HUBS 12MM

#365360	+4.5mm	6 SLOTS	OPTION
#365359	+3.75mm	5 SLOTS	OPTION
#365358	+3.0mm	4 SLOTS	OPTION
#365357	+2.25mm	3 SLOTS	OPTION

#365356	+1.5mm	2 SLOTS	OPTION
#365355	+0.75mm	1 SLOT	OPTION
#365353	0mm	0 SLOTS	INCLUDED
#365354	-0.75mm	Lightw.	OPTION
#365361	-1.25mm	Lightw.	OPTION



- 4x 902312 SH M3x12

2x L=R

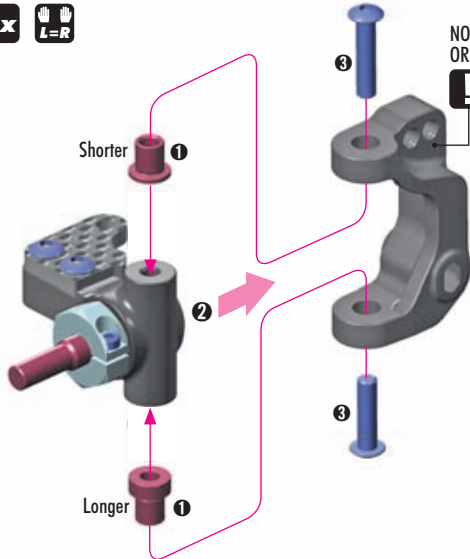

NOTE ORIENTATION

ROLL CENTER

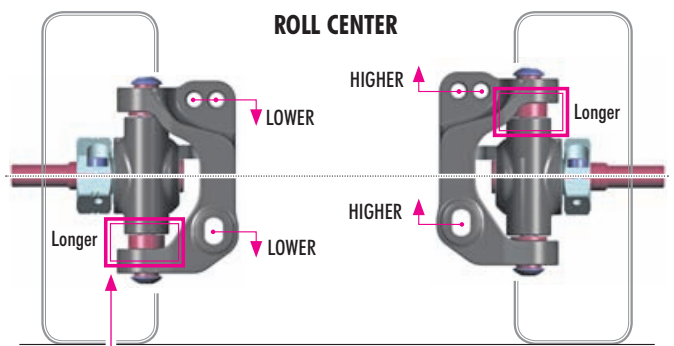

(INITIAL SETTING)

TOP = SHORTER bushing

BOTTOM = LONGER bushing

Recommended for smooth tracks to gain more steering.

OPTION

C-HUBS - LEFT

#322220-M	MEDIUM	INCLUDED
#322220-H	HARD	OPTION
#322220-G	GRAPHITE	OPTION

C-HUBS - RIGHT

#322210-M	MEDIUM	INCLUDED
#322210-H	HARD	OPTION
#322210-G	GRAPHITE	OPTION



MEDIUM

- For low traction. More steering on low grip.

HARD

- For medium traction. More steering, more free in corners.

GRAPHITE

- For high traction. More precise steering, less stopping in corners.

- 2x 306219 SHIM 3x6x2

- 2x 902254 SH M2.5x4

2x L=R

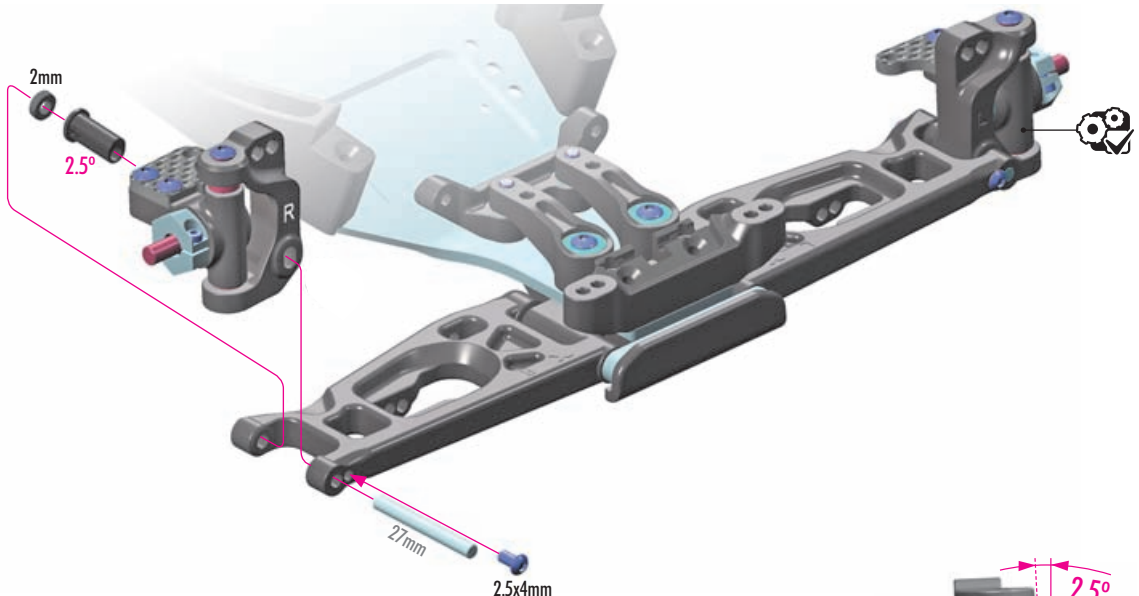

CASTER ECCENTRIC BUSHINGS

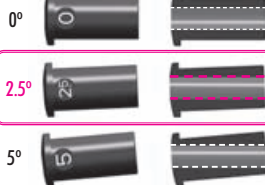

0°

2.5°

5°

LESS CASTER = increased steering off-power

MORE CASTER = less steering off-power

REAR

FRONT

CUTAWAY VIEW

ROLL CENTER LINKS

2x L=R

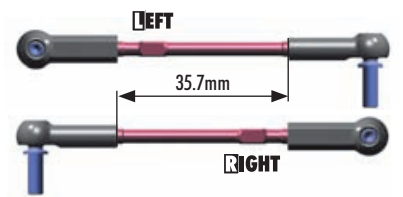
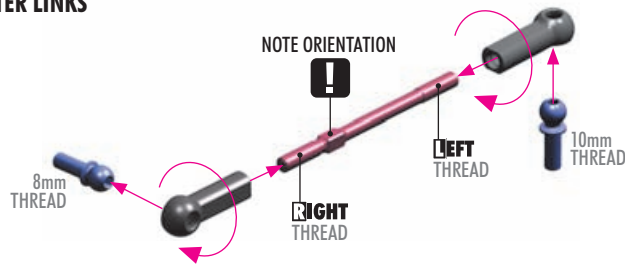

HUDY TITAN BALL ENDS			
OPTION	#990008	8mm Thread	OPTION
	#990010	10mm Thread	OPTION

ALU CONICAL SHIMS			
OPTION	#362280	SILVER	INCLUDED
	#362280-K	BLACK	OPTION
	#362280-O	ORANGE	OPTION

ROLL CENTER LINKS

4x 362280 CON. SHIM 3x6x2

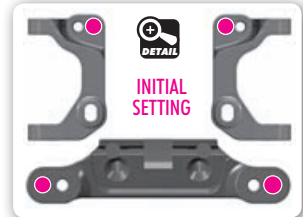
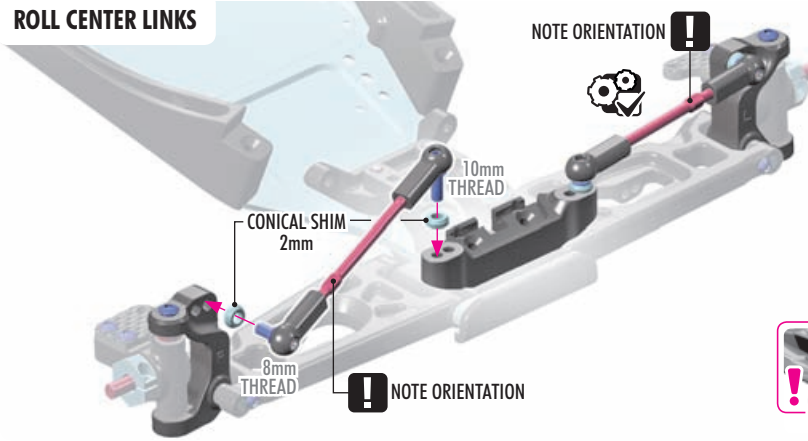

CARPET STEERING LINKS

2x L=R

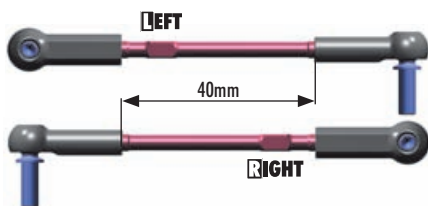
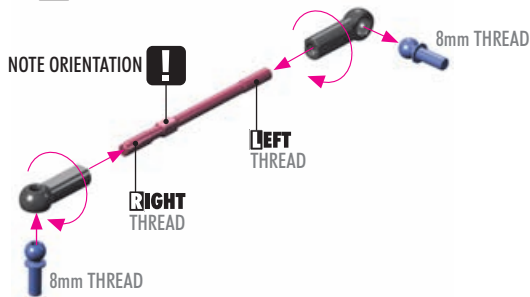

DIRT STEERING LINKS

2x L=R

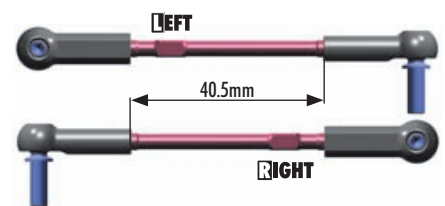
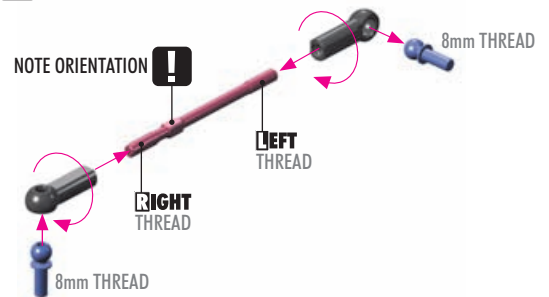

2x 362280 CON. SHIM 3x6x2

2x 960030 NUT M3

2x L=R

CARPET STEERING LINKS (INITIAL SETTING)

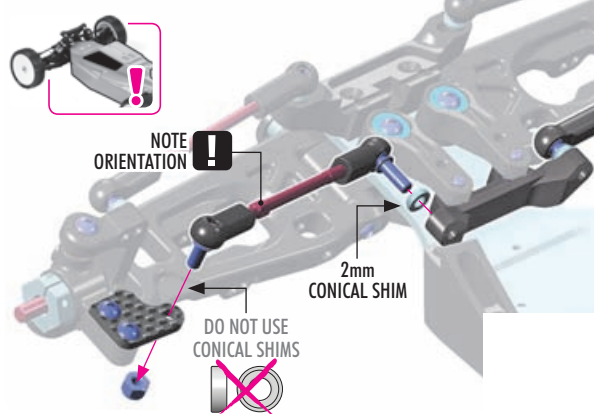

2x L=R

DIRT STEERING LINKS (INITIAL SETTING)

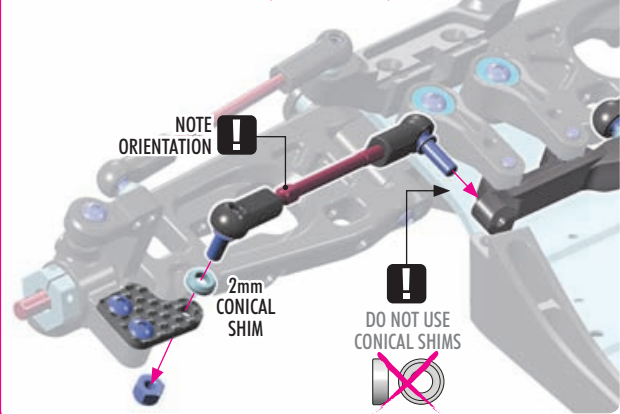

6. SHOCK ABSORBERS

CARPET DIRT

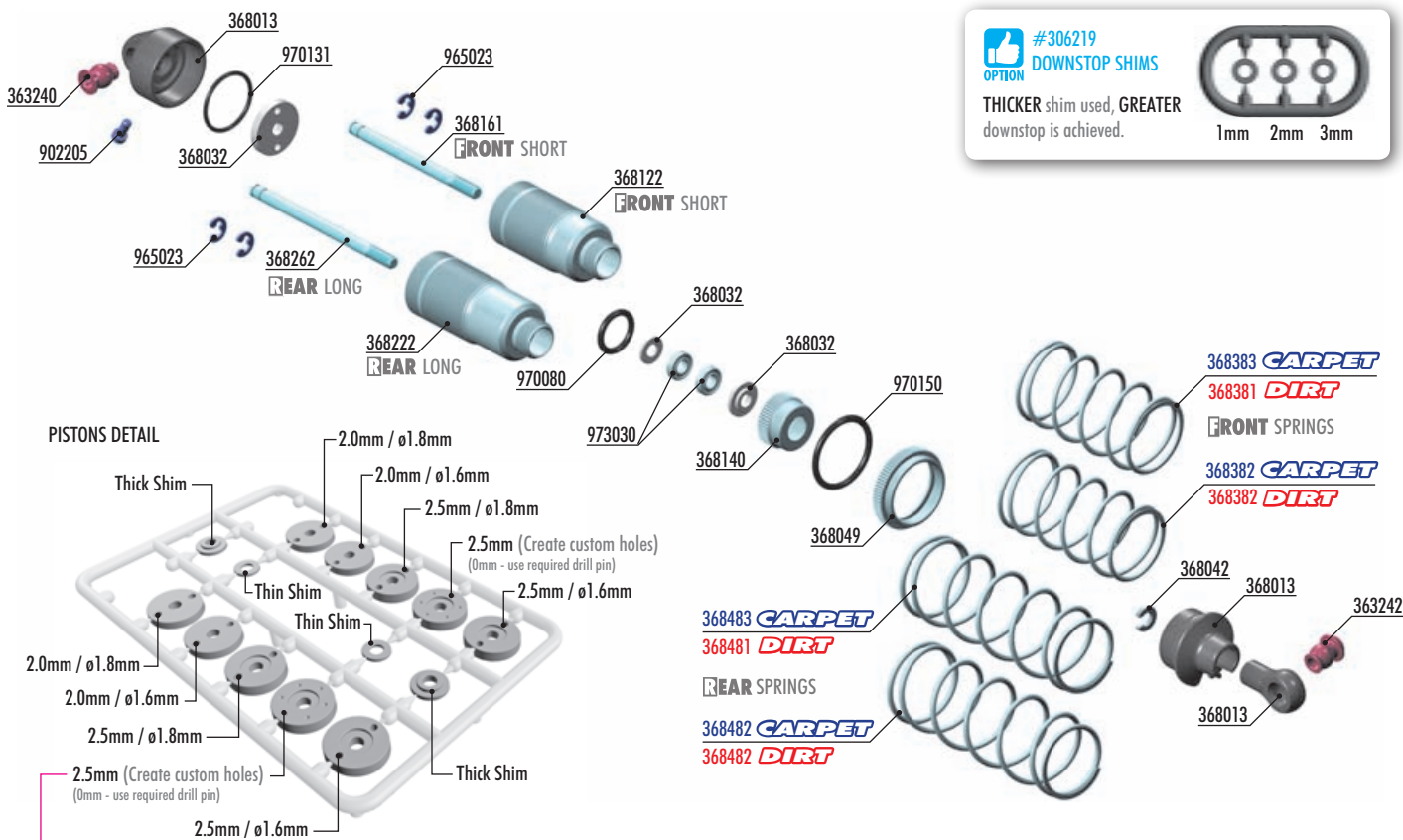

#306219 DOWNSTOP SHIMS
 THICKER shim used, GREATER downstop is achieved.
 1mm 2mm 3mm

! These pistons can NOT be used in shocks without making the custom holes by yourselves.

#368033 PRECISION GROUND SHOCK PISTON BLANKS 2.5MM - BIG BORE (4)

#368034 PRECISION GROUND SHOCK PISTON BLANKS 2.0MM - BIG BORE (4)

#104004 HUDY AIR VAC - VACUUM PUMP - 1/10 OFF-ROAD

#368054 ALU SHOCK CAP-NUT - BIG BORE (2)

#368021 ALU SHOCK SPRING RETAINING COLLAR (4)

#368022 ALU SHOCK SPRING RETAINING COLLAR -2mm (4)

#368023 ALU SHOCK SPRING RETAINING COLLAR -4mm (4)

FRONT SPRINGS			
#368381	L=42.5mm	1 DOTS	INCLUDED
#368382	L=42.5mm	2 DOTS	INCLUDED
#368382	L=42.5mm	2 DOTS	INCLUDED
#368383	L=42.5mm	3 DOTS	INCLUDED
#368384	L=42.5mm	4 DOTS	OPTION
#368385	L=42.5mm	5 DOTS	OPTION

REAR SPRINGS			
#368481	L=57.5mm	1 DOTS	INCLUDED
#368482	L=57.5mm	2 DOTS	INCLUDED
#368482	L=57.5mm	2 DOTS	INCLUDED
#368483	L=57.5mm	3 DOTS	INCLUDED
#368484	L=57.5mm	4 DOTS	OPTION
#368485	L=57.5mm	5 DOTS	OPTION

#368011 COMPOSITE SHOCK BALL JOINT +2mm & +4mm (2+2)

BAG 06

- 363240 BALL UNIVERSAL 5.8mm WITH BACKSTOP (2)
- 363242 PIVOT BALL 5.8mm ECCENTRIC (2)
- 368013 COMPOSITE SHOCK PARTS FOR 2 SHOCKS - BIG BORE
- 368032 SHOCK PISTONS - COMPLETE SET - DELRIN - BIG BORE
- 368049 ALU SHOCK ADJUSTABLE NUT - BIG BORE (2)
- 368042 COMPOSITE SHOCK BUSHING & SHIM (2+2)
- 368101 FRONT SHOCK ABSORBERS - BIG BORE - SET (2)
- 368122 ALU FRONT SHOCK BODY - BIG BORE (2)
- 368140 ALU LOWER SHOCK BODY CAP (2)
- 368161 FRONT HARDENED SHOCK SHAFT 42mm (2)
- 368201 REAR SHOCK ABSORBERS - BIG BORE - SET (2)
- 368222 ALU REAR SHOCK BODY - BIG BORE (2)
- 368262 REAR HARDENED SHOCK SHAFT 47mm (2)
- 902205 HEX SCREW SH M2x5 (10)
- 965023 E-CLIP 2.3 (10)

- 970080 O-RING 8x1 (10)
- 970131 O-RING 13 x 1.0 (10)
- 970150 O-RING 15 x 1.5 (10)
- 973030 SILICONE X-RING PRE-OILED 3x2 (10)

- CARPET**
- 368382 FRONT CONICAL SPRING-SET L=42.5mm - 2 DOTS (2)
 - 368383 FRONT CONICAL SPRING-SET L=42.5mm - 3 DOTS (2)
 - 368482 REAR CONICAL SPRING-SET L=57.5mm - 2 DOTS (2)
 - 368483 REAR CONICAL SPRING-SET L=57.5mm - 3 DOTS (2)
- DIRT**
- 368381 FRONT CONICAL SPRING-SET L=42.5mm - 1 DOT (2)
 - 368382 FRONT CONICAL SPRING-SET L=42.5mm - 2 DOTS (2)
 - 368481 REAR CONICAL SPRING-SET L=57.5mm - 1 DOT (2)
 - 368482 REAR CONICAL SPRING-SET L=57.5mm - 2 DOTS (2)

8x 965023
C2.3

SET-UP BOOK

SHOCK DAMPING
SHOCK PISTONS

PISTONS
ALTERNATIVE 1

We recommend for these types of surfaces and traction levels:
CARPET •

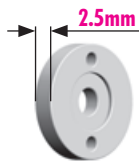

FRONT

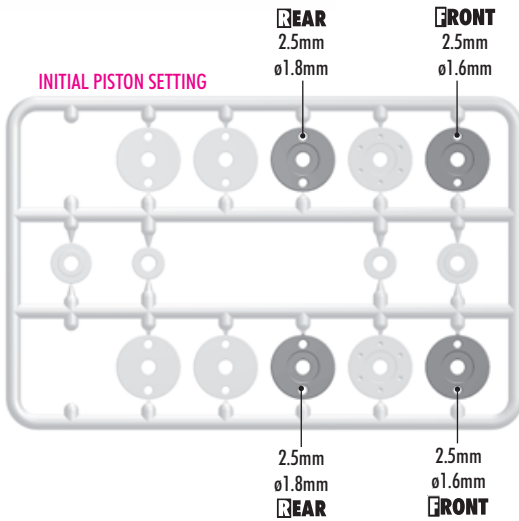
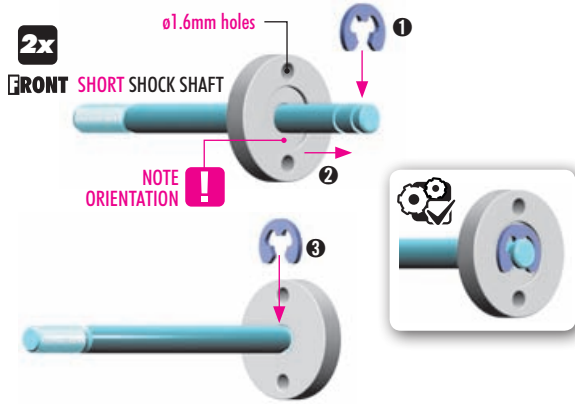

REAR

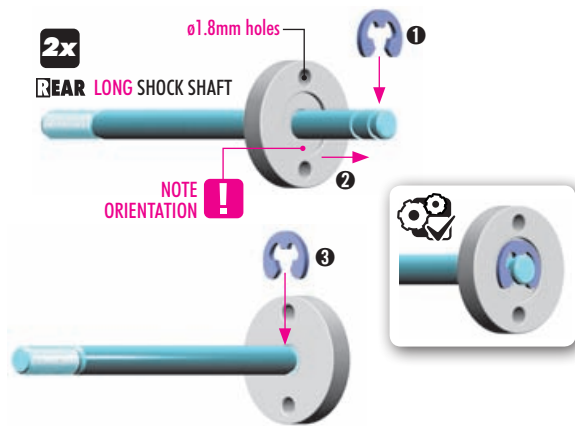

#368033
PRECISION GROUND SHOCK PISTON BLANKS 2.5MM - BIG BORE (4)
OPTION



Use drill bits to create your own piston holes

PISTONS
ALTERNATIVE 2

We recommend for these types of surfaces and traction levels:
• ASTRO
• DIRT



FRONT

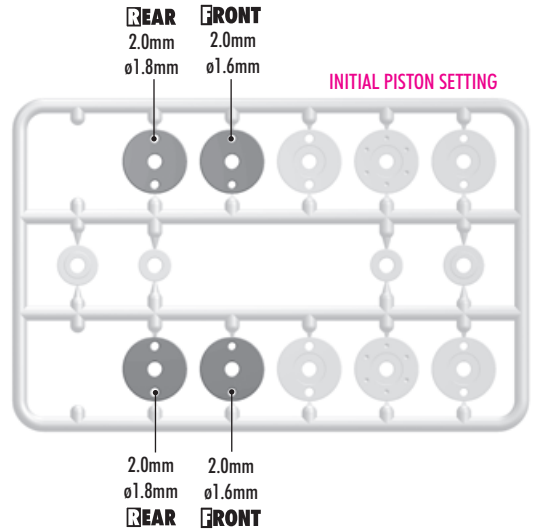
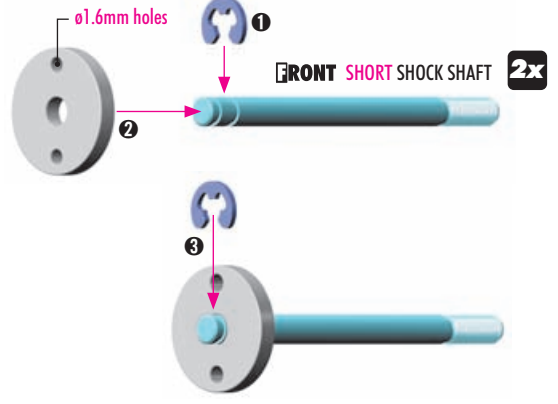

REAR

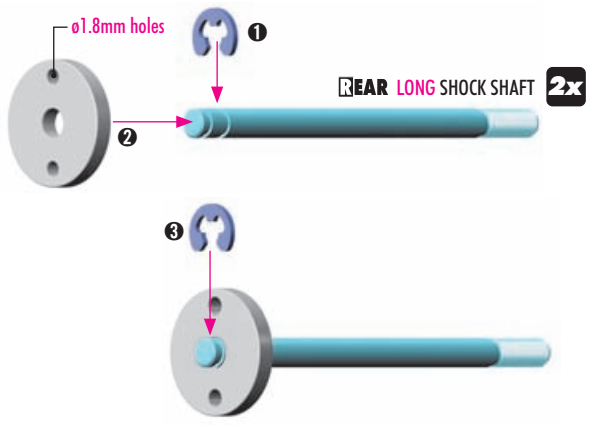

#368034
PRECISION GROUND SHOCK PISTON BLANKS 2.0MM - BIG BORE (4)
OPTION



6. SHOCK ABSORBERS

CARPET DIRT



4x 970080
O 8x1

8x 973030
X 3x2

There are two different thickness shims, use them as shown.
Use the same procedure when building both front and rear shocks.

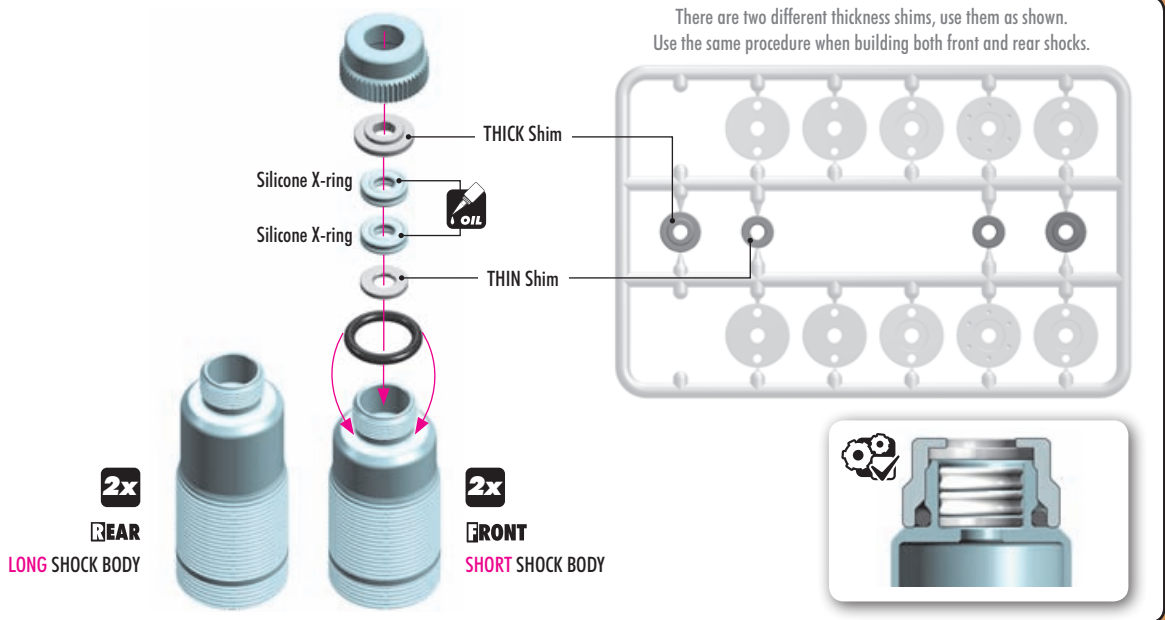

#306219 DOWNSTOP SHIMS

OPTION Add downstop shims to limit suspension travel. Thicker shims increase downstop and reduce droop. Thicker downstop shims reduce suspension travel.

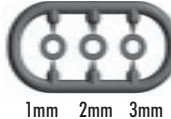

! IMPORTANT
Always use same shim thickness on right and left side to achieve same downstop.

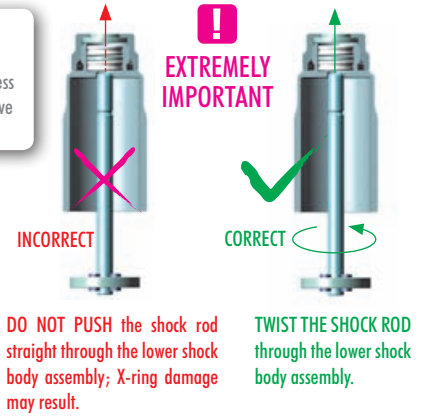
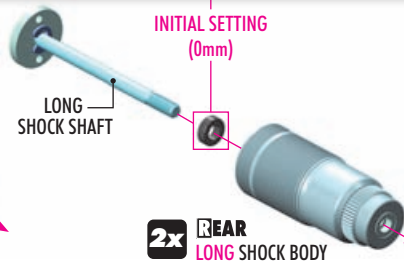
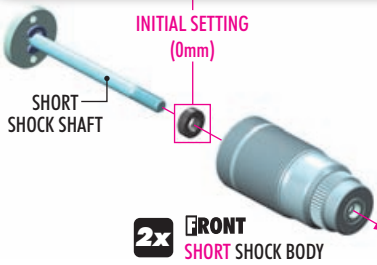

4x 970150
O 15x1.5

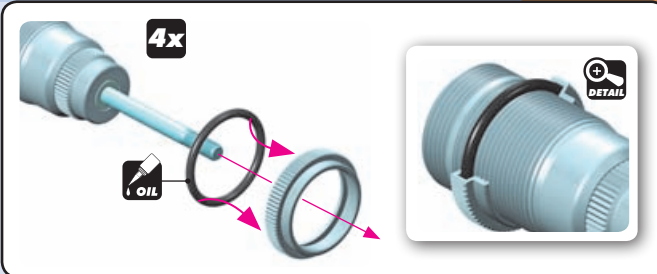

4x 970131
O 13x1

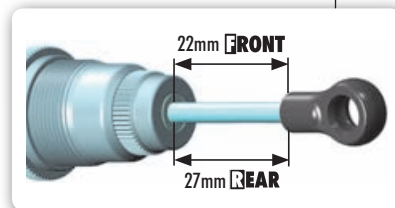
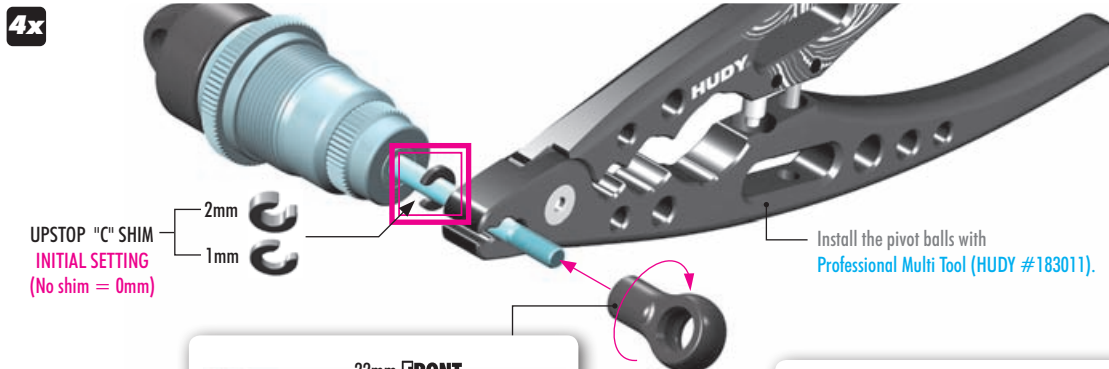
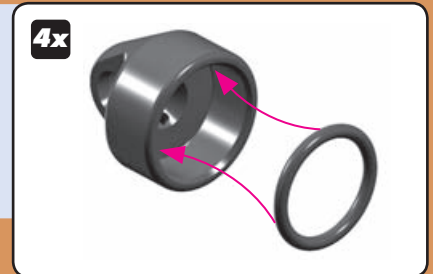

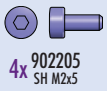

CARPET
FRONT (SHORT)
Oil 300cSt
REAR (LONG)
Oil 300cSt

DIRT
FRONT (SHORT)
Oil 300cSt
REAR (LONG)
Oil 300cSt

DEFAULT SHOCK REBOUND SETTING 0% REBOUND

Follow the steps below to set the shock rebound to the default setting of 0%.

- Extend the shock shaft completely. Fill the shock body with the shock oil. For the **FRONT** shocks (short) use 300cSt oil. For the **REAR** shocks (long) use 300cSt oil.
- Move the shock shaft up and down a few times to release the air bubbles trapped beneath the piston. 3~5x UP & DOWN
- Orient the filled shock vertically for several minutes with the shock shaft fully extended. The remaining air bubbles will release.
- TIGHTEN FULLY. Gently place the shock cap onto the filled shock body and start to tighten the cap fully.
- Gently push the shock shaft completely into the shock body. Excess oil will flow through the hole in the shock cap.
- Keep the shock shaft pushed in the shock body and insert the screw into the shock cap. Tighten gently.
- 6x push the shaft up and down.
- Untighten the screw.
- Gently push the shock shaft completely into the shock body. Excess oil will flow through the hole in the shock cap.
- Tighten the screw. The rebound will be at approx. 0%.

SET-UP BOOK
SHOCK OIL

SHORT FRONT SHOCKS 2x Short Springs
LONG REAR SHOCKS 2x Long Springs

WIDE NUT
SPRINGS
NOTE ORIENTATION
NARROW COLLAR

WIDE SIDE ON TOP
NARROW SIDE ON BOTTOM

REAR FRONT

We recommend for these types of surfaces and traction:

INITIAL STARTING SETTINGS		
SURFACE	FRONT	REAR
CARPET	3 DOTS	3 DOTS
ASTRO	2 DOTS	2 DOTS
DIRT	1 DOT	1 DOT

#368021 ALU SHOCK SPRING RETAINING COLLAR (4)
OPTION

#368022 ALU SHOCK SPRING RETAINING COLLAR -2mm (4)
OPTION

#368023 ALU SHOCK SPRING RETAINING COLLAR -4mm (4)
OPTION

IMPORTANT
Check that Front and Rear shock pairs are the same overall length.

2x FRONT
2x REAR



HUDY TITAN BALL ENDS

#990008	8mm Thread	OPTION
#990010	10mm Thread	OPTION

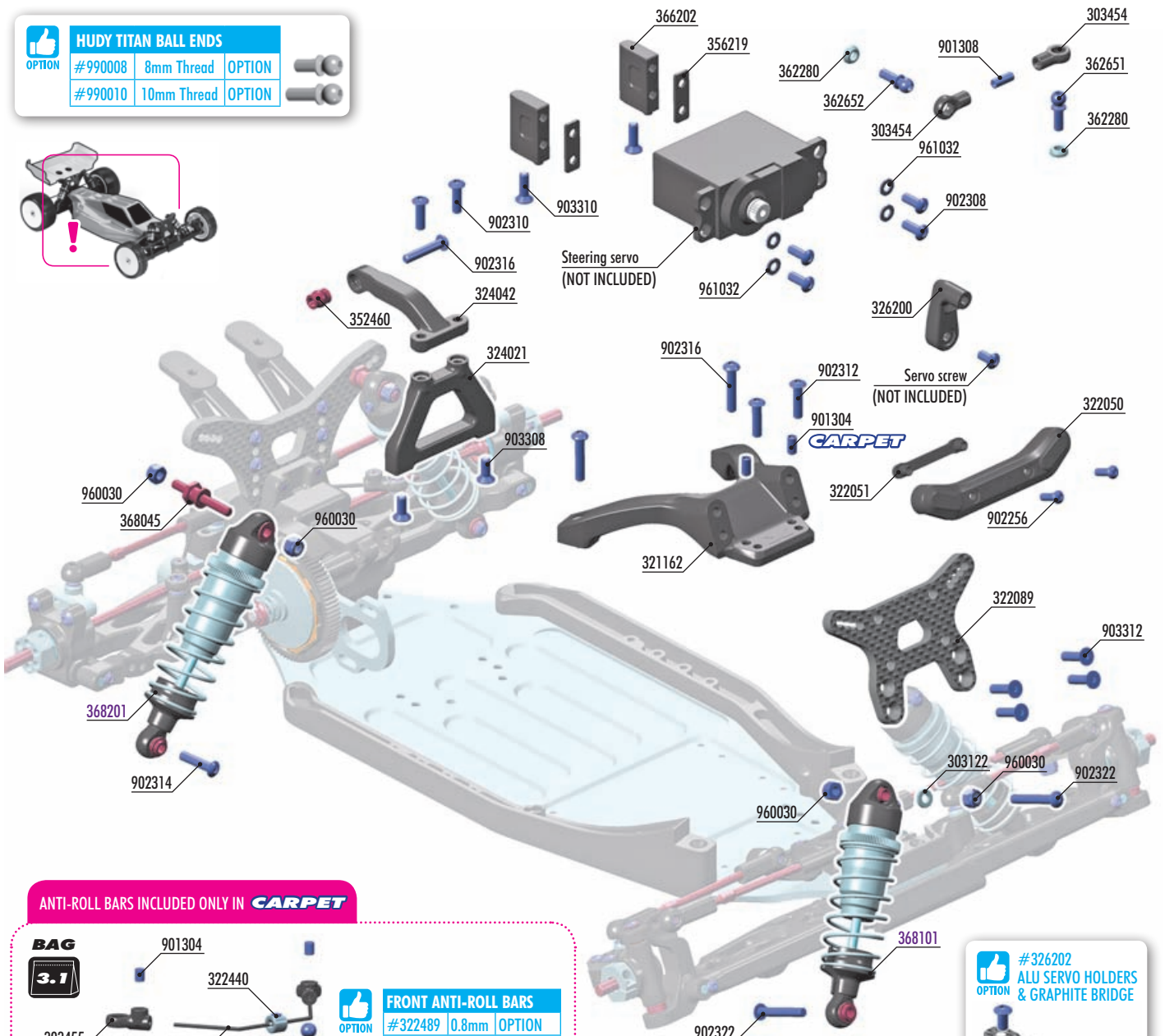

ANTI-ROLL BARS INCLUDED ONLY IN CARPET



3.1

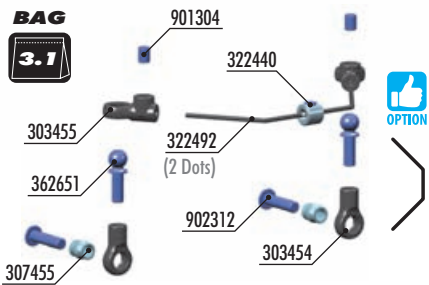

FRONT ANTI-ROLL BARS

#322489	0.8mm	OPTION
#322490	1.0mm	OPTION
#322491	1.1mm	OPTION
#322492	1.2mm	INCLUDED
#322493	1.3mm	OPTION



#326202
ALU SERVO HOLDERS & GRAPHITE BRIDGE



BAG

07

- 303122 ALU SHIM 3x6x1.0mm (10)
- 303454 BALL JOINT 4.9mm - OPEN (4)
- 321162 COMPOSITE FRONT BRIDGE UPPER DECK
- 322050 COMPOSITE FRONT SHOCK TOWER PROTECTOR
- 322051 COMPOSITE FRONT SHOCK TOWER INSERT (2)
- 322089 XB2 GRAPHITE SHOCK TOWER FOR BRIDGE UPPER DECK - FRONT
- 324021 COMPOSITE MOUNT FOR UPPER BRACE - LCG
- 324042 COMPOSITE MOTOR UPPER BRACE - LCG
- 326200 COMPOSITE STEERING SERVO ARMS - EXTENDED - 23T + 25T
- 352460 PIVOT BALL 5.8 (10)
- 356219 COMPOSITE SERVO SHIMS 1.0, 1.5 & 2.5mm (2+2+2)
- 362280 ALU CONICAL SHIM 3x6x2.0mm (10)
- 362651 BALL ENDS 4.9mm WITH THREAD 8mm (2)
- 362652 BALL ENDS 4.9mm WITH THREAD 10mm (2)
- 366202 COMPOSITE SERVO MOUNT - HIGHER
- 368045 STEEL SCREW SHOCK PIVOT BALL WITH HEX (2)

- 901308 HEX SCREW SB M3x8 (10)
- 902256 HEX SCREW SH M2.5x6 (10)
- 902308 HEX SCREW SH M3x8 (10)
- 902310 HEX SCREW SH M3x10 (10)
- 902312 HEX SCREW SH M3x12 (10)
- 902314 HEX SCREW SH M3x14 (10)
- 902316 HEX SCREW SH M3x16 (10)
- 902322 HEX SCREW SH M3x22 (10)
- 903308 HEX SCREW SFH M3x8 (10)
- 903310 HEX SCREW SFH M3x10 (10)
- 903312 HEX SCREW SFH M3x12 (10)
- 960030 NUT M3 (10)
- 961032 WASHER S 3.2 (10)

- 368101 FRONT SHOCK ABSORBERS - BIG BORE - SET (2)
- 368201 REAR SHOCK ABSORBERS - BIG BORE - SET (2)

CARPET

BAG

3.1

- 303454 COMPOSITE BALL JOINT 4.9mm - OPEN (4)
- 303455 COMPOSITE ANTI-ROLL BAR BALL JOINT 4.9mm (4)
- 307455 PIVOT BALL 4.9mm DOUBLE BEVEL SHOULDERS (10)
- 322440 ALU ANTI-ROLL BAR COLLAR
- 322492 XB2 ANTI-ROLL BAR FRONT FOR BRIDGE UPPER DECK - 1.2mm
- 362651 BALL ENDS 4.9mm WITH THREAD 8mm (2)
- 901304 HEX SCREW SB M3x4 (10)
- 902312 HEX SCREW SH M3x12 (10)

7. FINAL ASSEMBLY

CARPET DIRT

1x 901308
SB M3x8

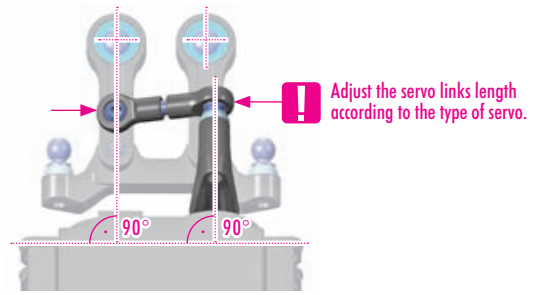
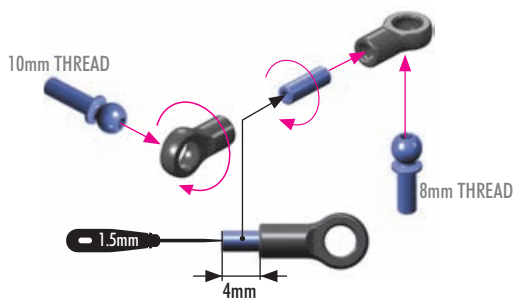

1x 362280
CON. SHIM 3x6x2

4x 902308
SH M3x8

4x 961032
SHIM S 3.2

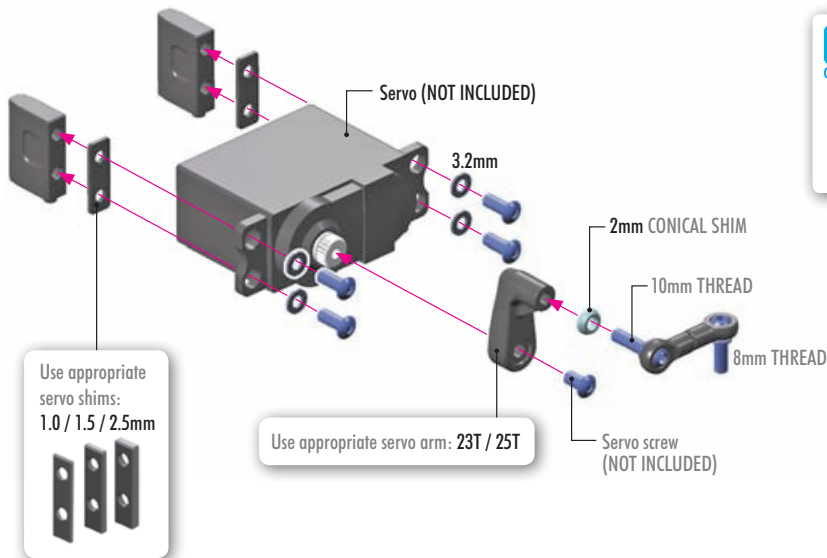

CLAMP ALU SERVO HORNS - EXTENDED

#326221 KO, Sanwa - 23T

#326222 Futaba, Savox - 25T

For more in-corner steering and better steering response, aluminum servo horns may be used.



#326202 ALU SERVO HOLDERS & GRAPHITE BRIDGE



1x 362280
CON. SHIM 3x6x2

2x 903310
SFH M3x10

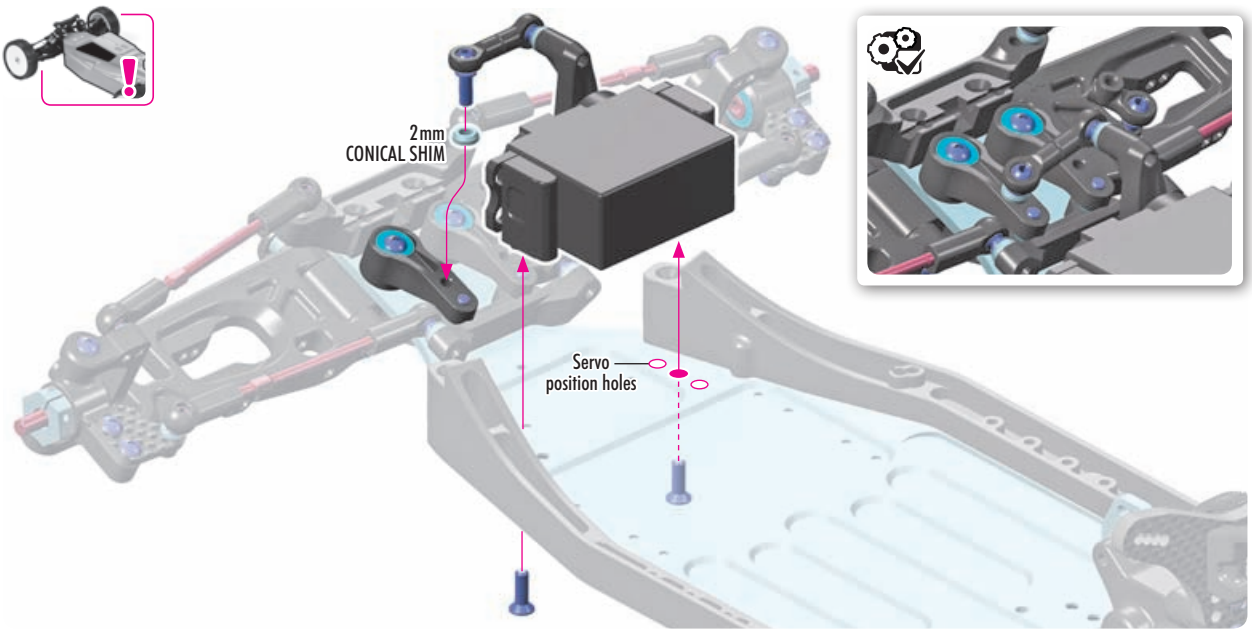

FRONT ANTI-ROLL BAR

Steps only for Carpet edition.

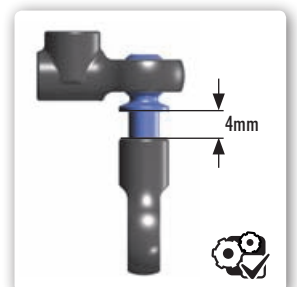
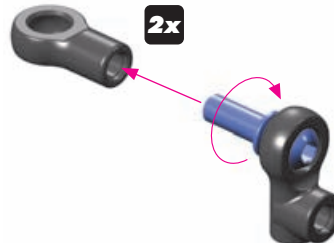

FRONT ANTI-ROLL BAR
CARPET

2x 902312
SH M3x12

FRONT ANTI-ROLL BAR
CARPET

Setscrew is already threaded in collar. **2**

Set the collar into the **CENTER**

1x 901302
SB M3x2.5

FRONT ANTI-ROLL BARS		
OPTION	#322489	0.8mm OPTION
	#322490	1.0mm OPTION
	#322491	1.1mm OPTION
	#322492	1.2mm INCLUDED
	#322493	1.3mm OPTION

FRONT ANTI-ROLL BAR
CARPET

2x 901304
SB M3x4

FRONT ANTI-ROLL BAR
CARPET

2x 901304
SB M3x4

2x 902312
SH M3x12

2x 902316
SH M3x16

3x12mm

Set screw only in **CARPET EDITION**

3x16mm

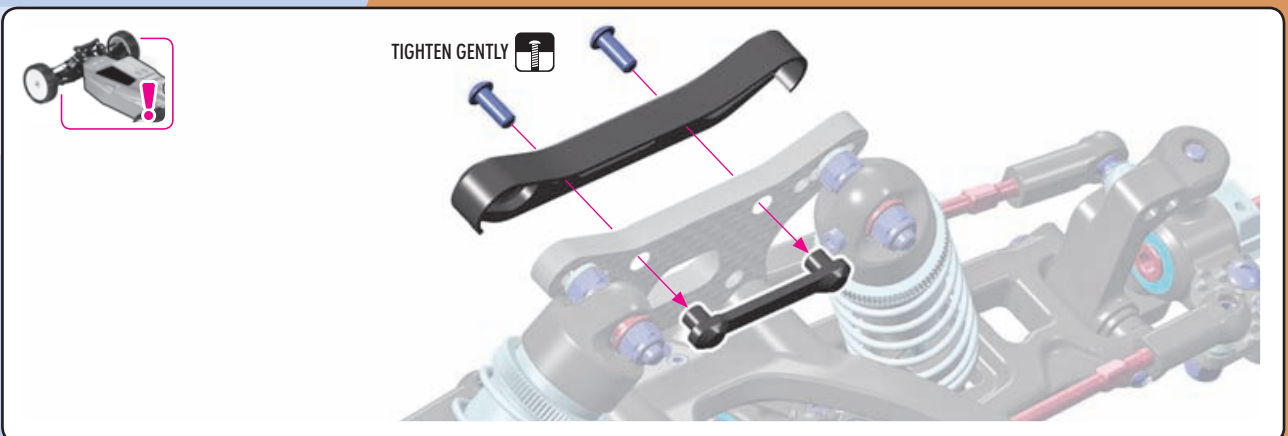
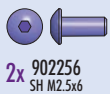
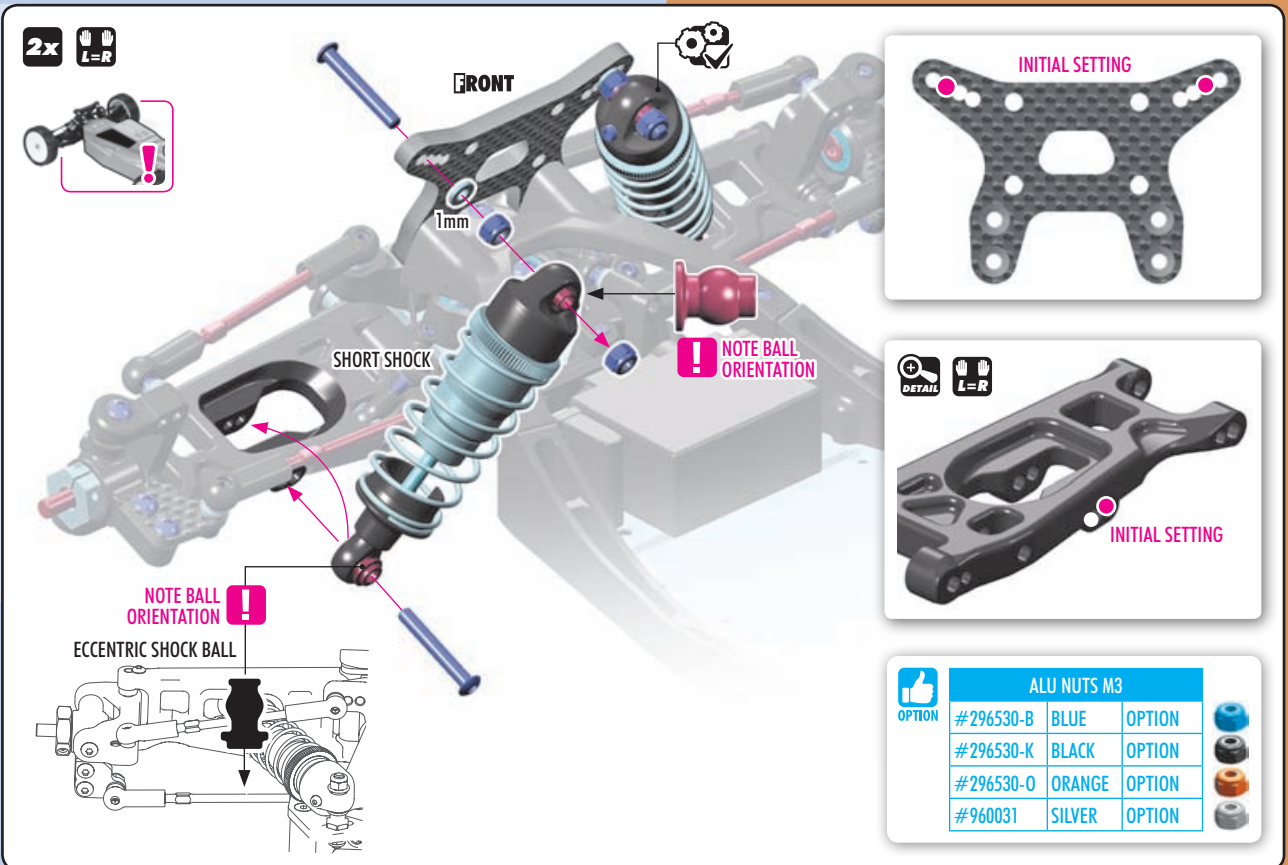
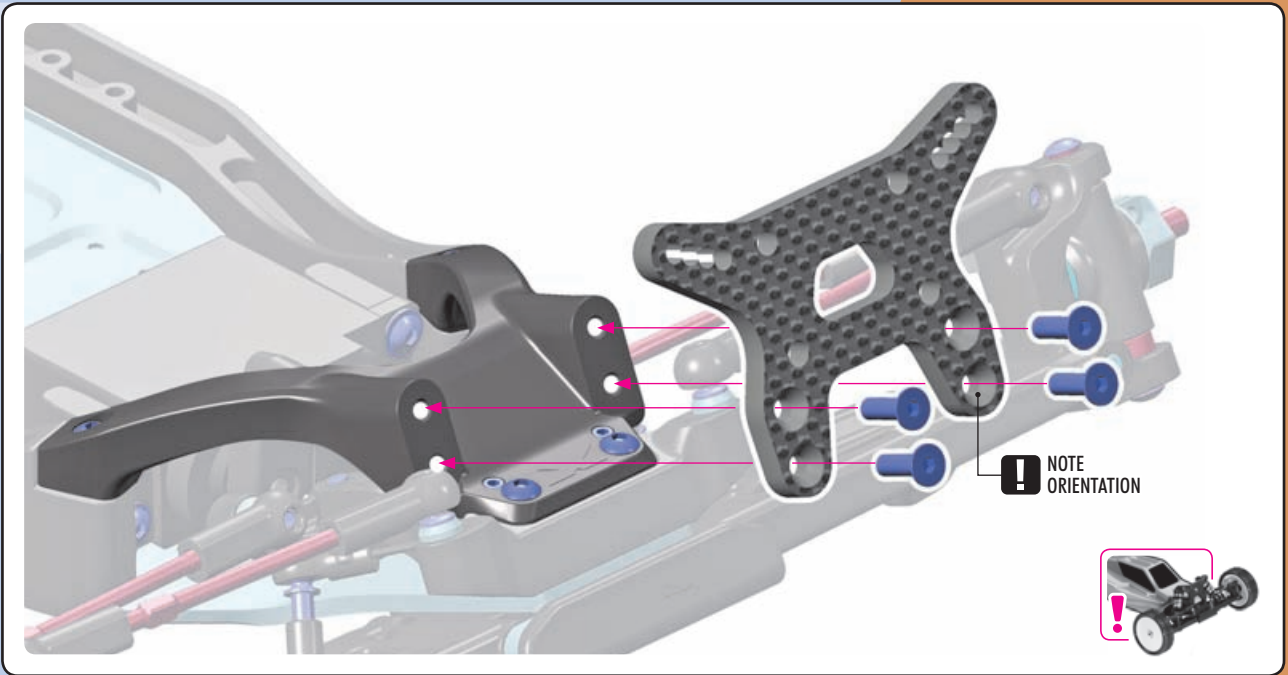

- 

2x 902314
SH M3x14
- 

4x 960030
NUT M3

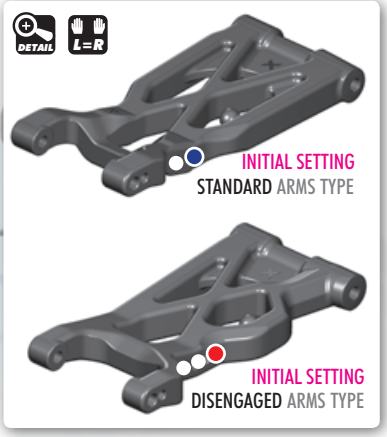
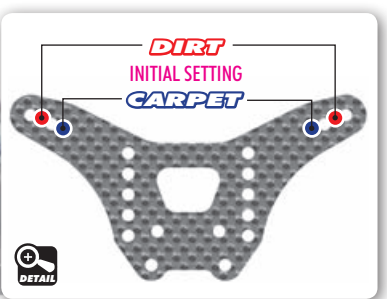
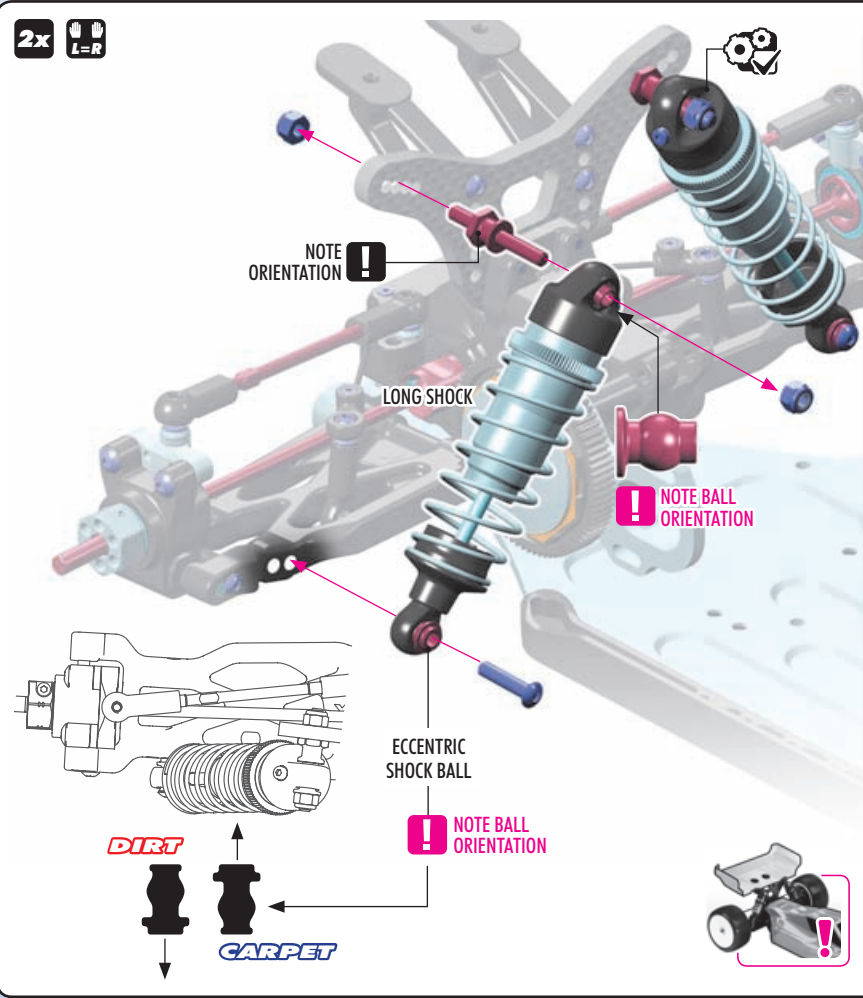

ALU NUTS M3

OPTION	ALU NUTS M3	OPTION
#296530-B	BLUE	OPTION
#296530-K	BLACK	OPTION
#296530-O	ORANGE	OPTION
#960031	SILVER	OPTION

- 

2x 902310
SH M3x10
- 

1x 902316
SH M3x16
- 

2x 903308
SFH M3x8

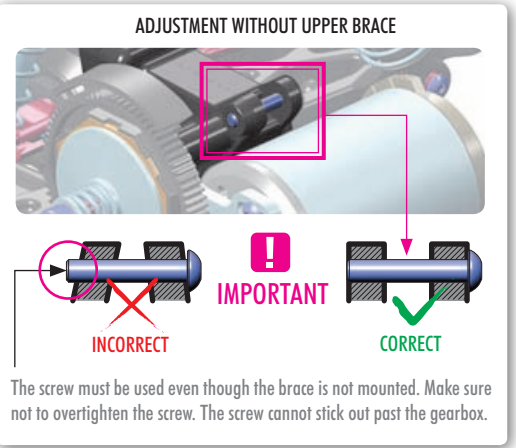
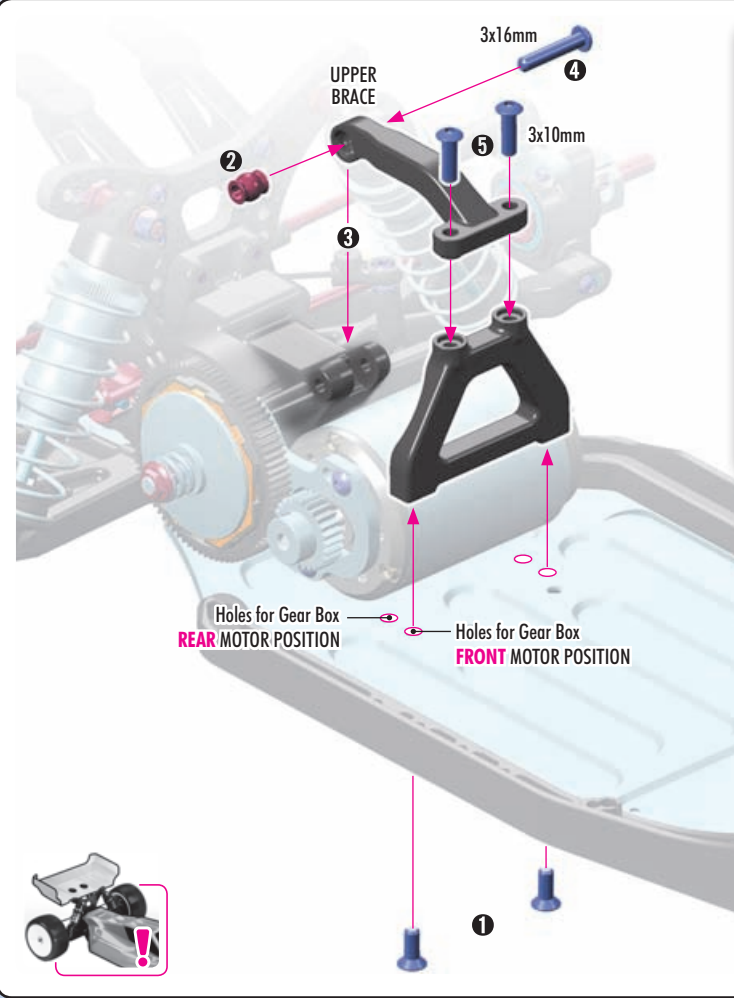

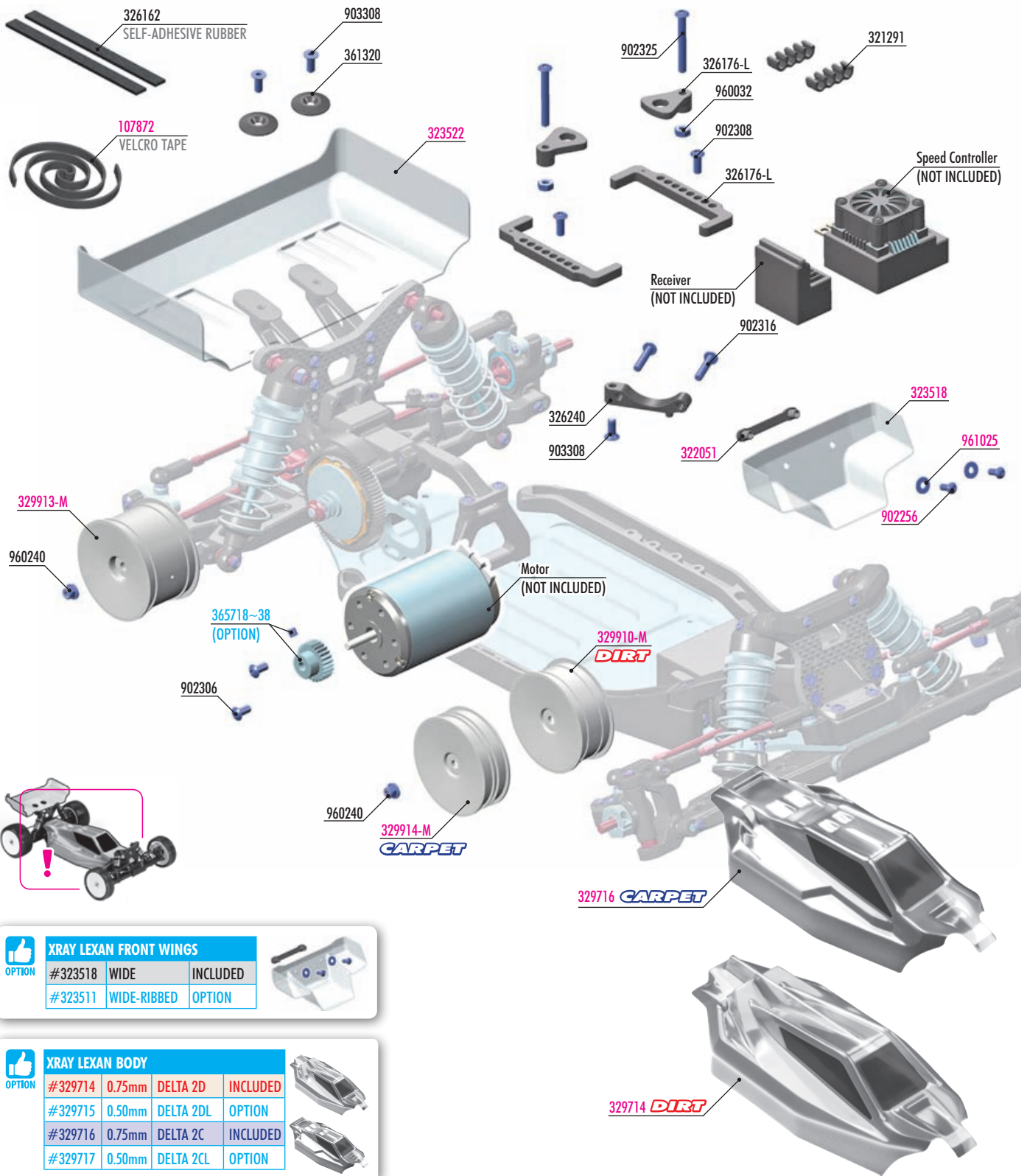

OPTION

XRAY LEXAN FRONT WINGS		
#323518	WIDE	INCLUDED
#323511	WIDE-RIBBED	OPTION

OPTION

XRAY LEXAN BODY			
#329714	0.75mm	DELTA 2D	INCLUDED
#329715	0.50mm	DELTA 2DL	OPTION
#329716	0.75mm	DELTA 2C	INCLUDED
#329717	0.50mm	DELTA 2CL	OPTION



- 321291 COMPOSITE 5-WIRES HOLDER - SET
- 326162 SELF-ADHESIVE RUBBER 1.5x6.5x155mm (2)
- 326176-L COMPOSITE LIPO BATTERY HOLDER - LONG (2+2)
- 326240 COMPOSITE FAN HOLDER
- 361320 BODY MOUNT, BATTERY MOUNT - V2 & WING SHIM (2)
- 902306 HEX SCREW SH M3x6 (10)
- 902308 HEX SCREW SH M3x8 (10)
- 902316 HEX SCREW SH M3x16 (10)
- 902325 HEX SCREW SH M3x25 (10)
- 903308 HEX SCREW SFH M3x8 (10)
- 960032 NUT M3 (10)
- 960240 NUT M4 WITH SERRATED FLANGE (10)

- 107872 VELCRO TAPE WITH DOUBLE SIDED TAPE 8x500mm
- 322051 COMPOSITE FRONT SHOCK TOWER INSERT (2)
- 323518 LEXAN FRONT WING - WIDE
- 323522 LEXAN REAR WING - LUSH
- 329913-M REAR WHEEL AERODISK WITH 12MM HEX IFMAR - WHITE (2)
- 902256 HEX SCREW SH M2.5x6 (10)
- 961025 WASHER S 2.5 (10)

CARPET

- 329716 BODY FOR 1/10 2WD OFF-ROAD BUGGY - DELTA 2C
- 329914-M 2WD FRONT SLIM WHEEL AERODISK WITH NARROW OFFSET - WHITE (2)

DIRT

- 329714 BODY FOR 1/10 2WD OFF-ROAD BUGGY - DELTA 2D
- 329910-M FRONT WHEEL AERODISK WITH 12MM HEX IFMAR - WHITE (2)

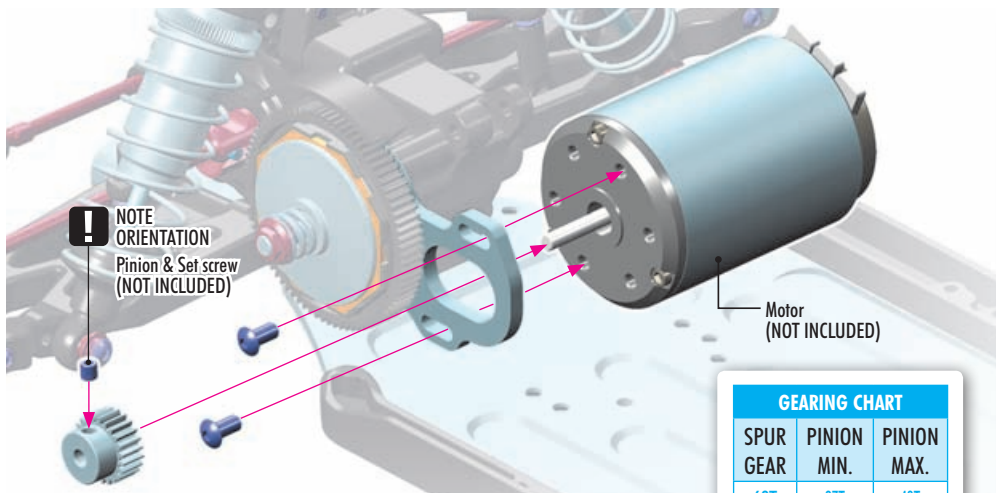

NOTE ORIENTATION
Pinion & Set screw
(NOT INCLUDED)

Motor
(NOT INCLUDED)

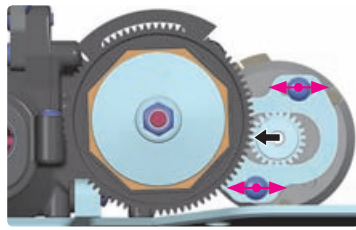

GEAR MESH

Adjust the motor so the pinion meshes with the spur gear properly. Make sure the gear mesh is not too tight.

There should be a small amount of play between the teeth of the pinion gear and the spur gear.

GEARING CHART

SPUR GEAR	PINION MIN.	PINION MAX.
69T	27T	43T
72T	24T	40T
75T	21T	37T
78T	18T	34T
81T	15T	31T

GEAR RATIO Final Drive Ratio
 $78 : X \times 2.65 = \text{FDR}$
(Spur) (Pinion) (IGR)



PINIONS (48P)

#294017	17T
#305918	18T
#305919	19T
#294020	20T
#294021	21T
#294022	22T
#294023	23T
#305924	24T
#305925	25T
#365726	26T
#365727	27T
#365728	28T
#365729	29T
#365730	30T
#365731	31T
#365732	32T
#365733	33T
#365734	34T
#365735	35T
#365736	36T
#365737	37T
#365738	38T

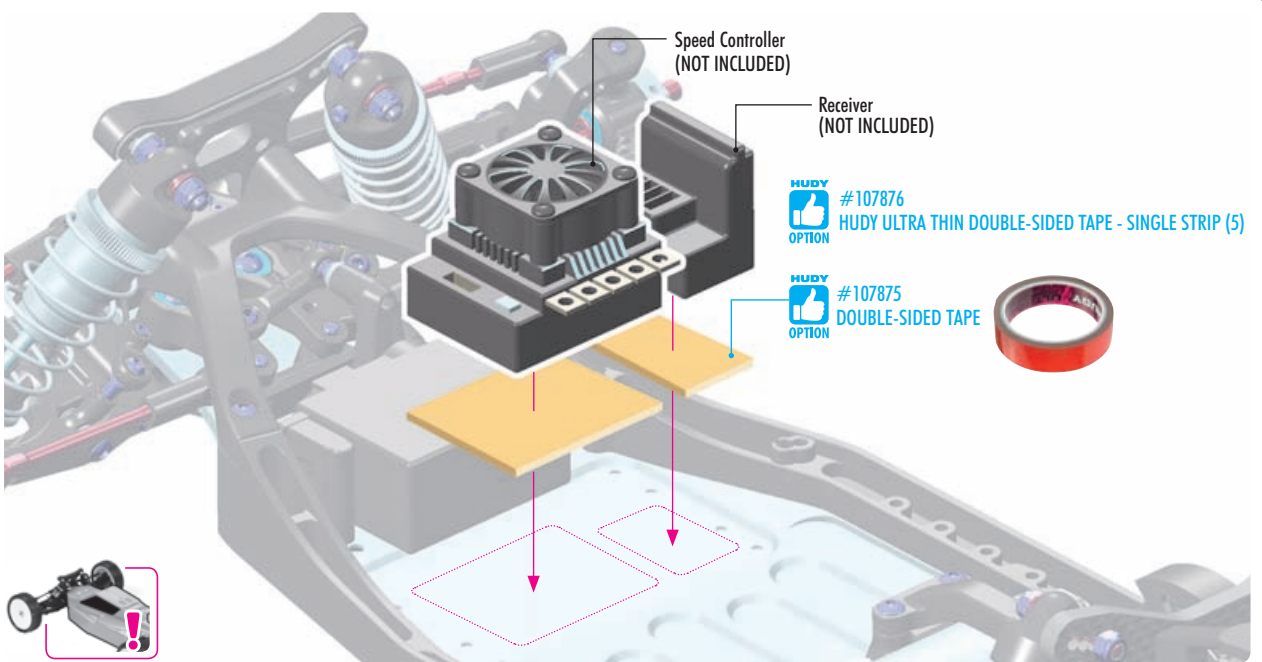

Speed Controller
(NOT INCLUDED)

Receiver
(NOT INCLUDED)



#107876

HUDY ULTRA THIN DOUBLE-SIDED TAPE - SINGLE STRIP (5)



#107875

DOUBLE-SIDED TAPE



CHASSIS TUNING

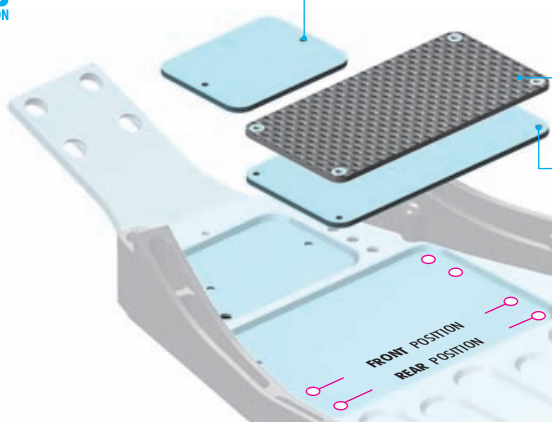

#326153

STAINLESS STEEL WEIGHT UNDER SERVO FOR 1-PIECE CHASSIS 13g
(Including 2pcs Hex screws 110° SFH M2x3 #913203)



#326149

GRAPHITE PLATE FOR ELECTRONICS FOR 1-PIECE CHASSIS - SET
(Including 4pcs Hex screws 110° SFH M2x3 #913203)



#326152

STAINLESS STEEL WEIGHT FOR ELECTRONICS 1-PIECE CHASSIS 30g
(Including 4pcs Hex screws 110° SFH M2x3 #913203)



2x 902308
SH M3x8



2x 902325
SH M3x25



2x 960032
NUT M3

NOTE ORIENTATION
for **LOW BATTERY PACK**



NOTE ORIENTATION
for **STANDARD BATTERY PACK**



To ensure correct functioning of the battery holder, **DO NOT** overtighten the screw; the holder must be able to move.

DO NOT overtighten the screw to avoid side guard damage.

#326181
STAINLESS STEEL BATTERY WEIGHT 35g
OPTION



Battery
(NOT INCLUDED)

BATTERY POSITION SETTING
CARPET DIRT

For **INITIAL SETTING** use the battery position setting maximum in rearward position.

ORIENTATION FOR
STANDARD BATTERY PACK

ORIENTATION FOR
LOW BATTERY PACK

HEIGHT ADJUSTMENT
1 turn = 0.5mm

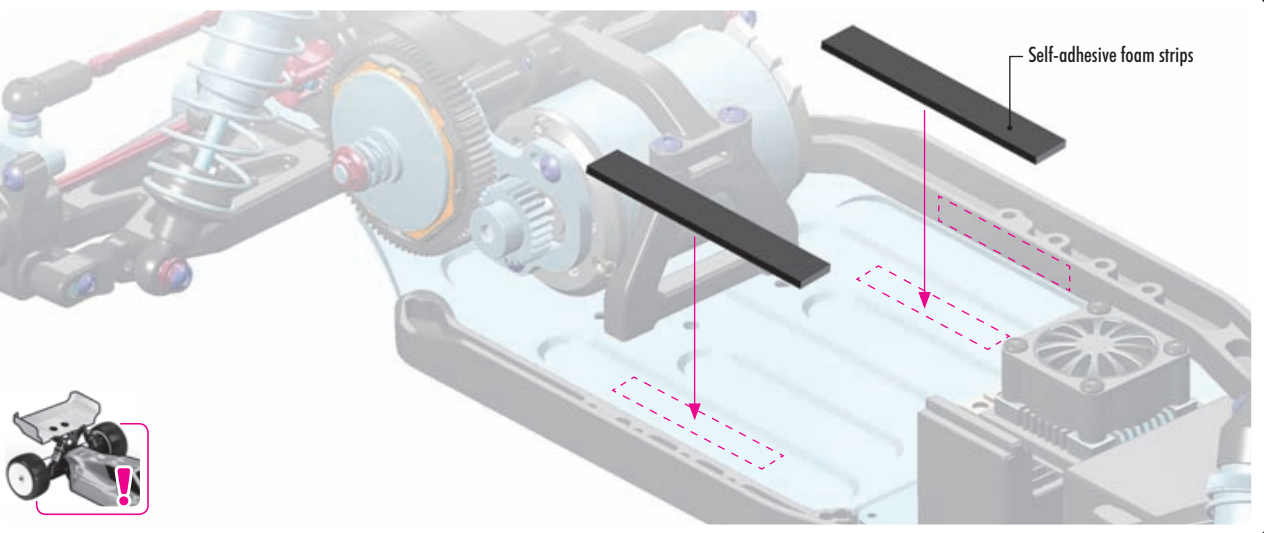

Self-adhesive foam strips



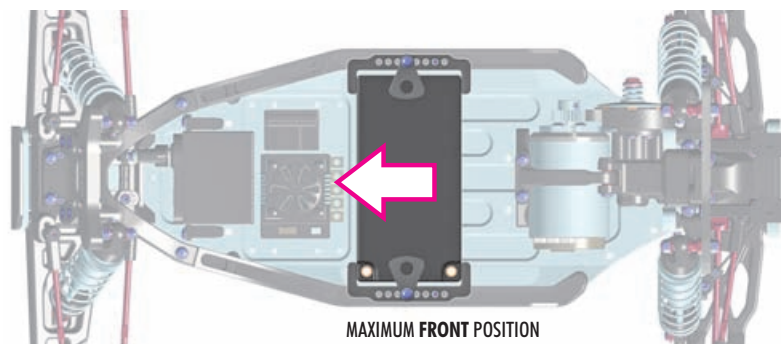
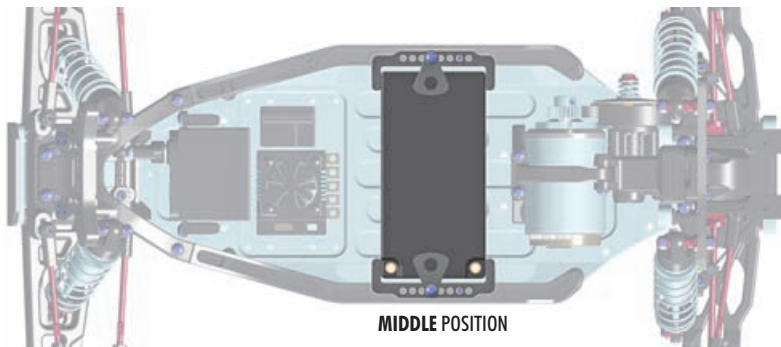
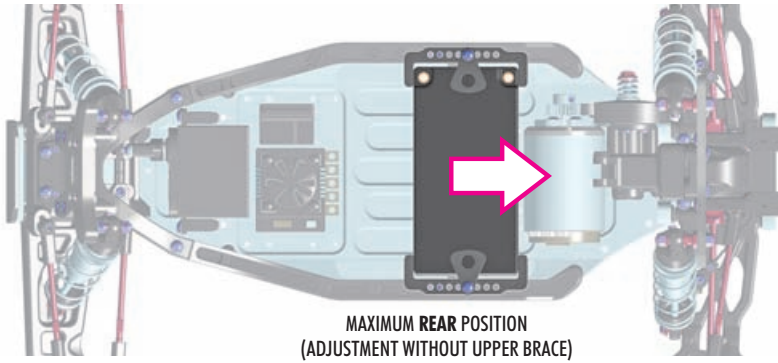
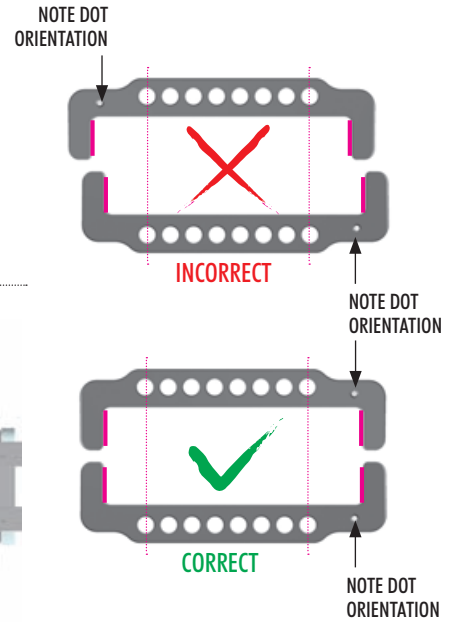
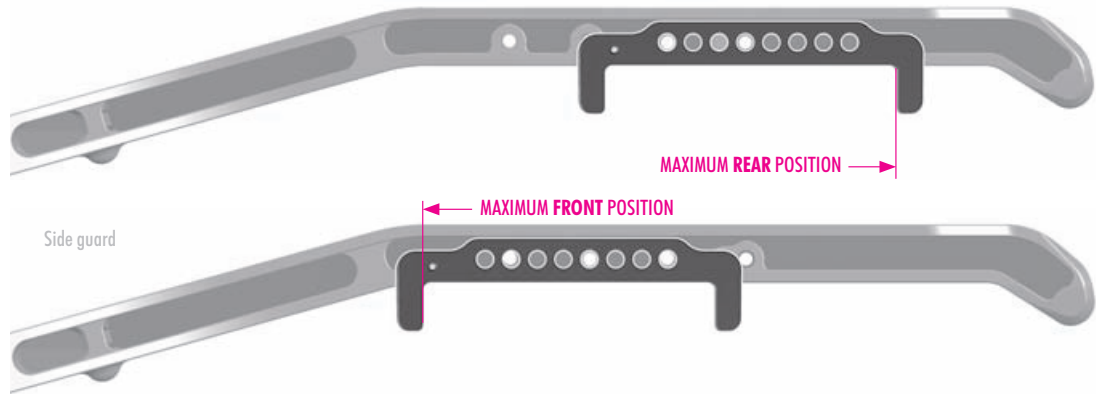



2x 902316
SH M3x16



1x 903308
SFH M3x8

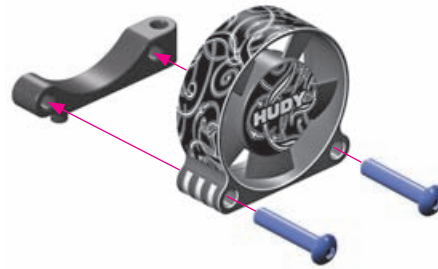

#293101
OPTION HUDY ALU RC FAN 30MM
SIDE MOUNT 2 HOLE



#293112
OPTION HUDY BRUSHLESS RC FAN 30MM
WITH INTERNAL SOLDERING TABS



#293110
OPTION HUDY BRUSHLESS RC FAN 30MM
WITH EXTERNAL SOLDERING TABS



ALTERNATIVE 1 FAN ASSEMBLY BEHIND MOTOR

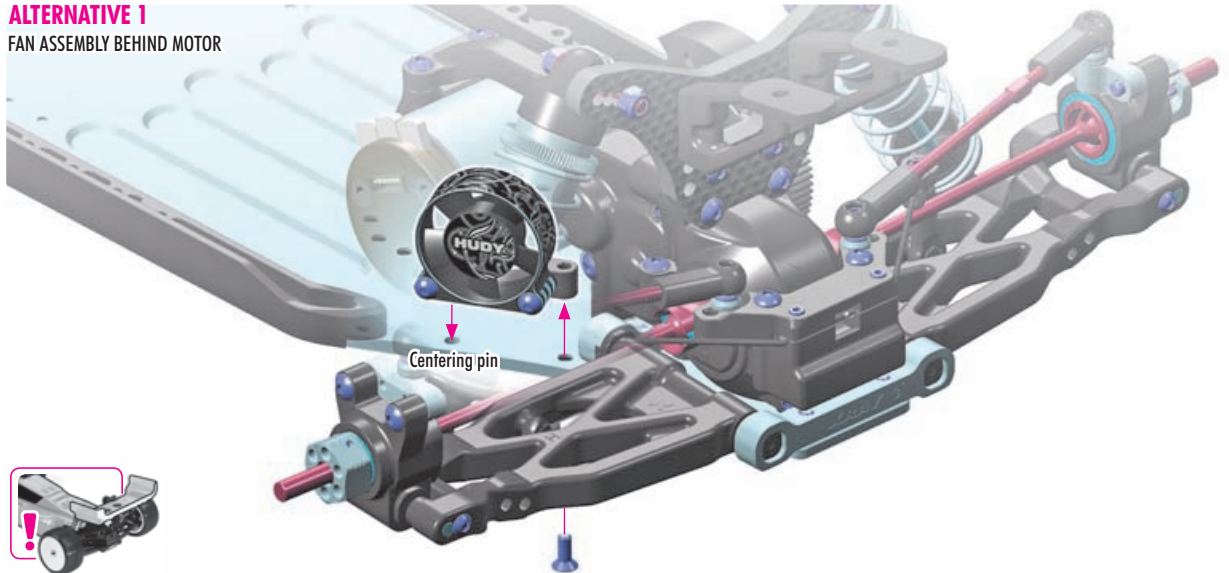

ALTERNATIVE 2 FAN ASSEMBLY BETWEEN BATTERY & MOTOR

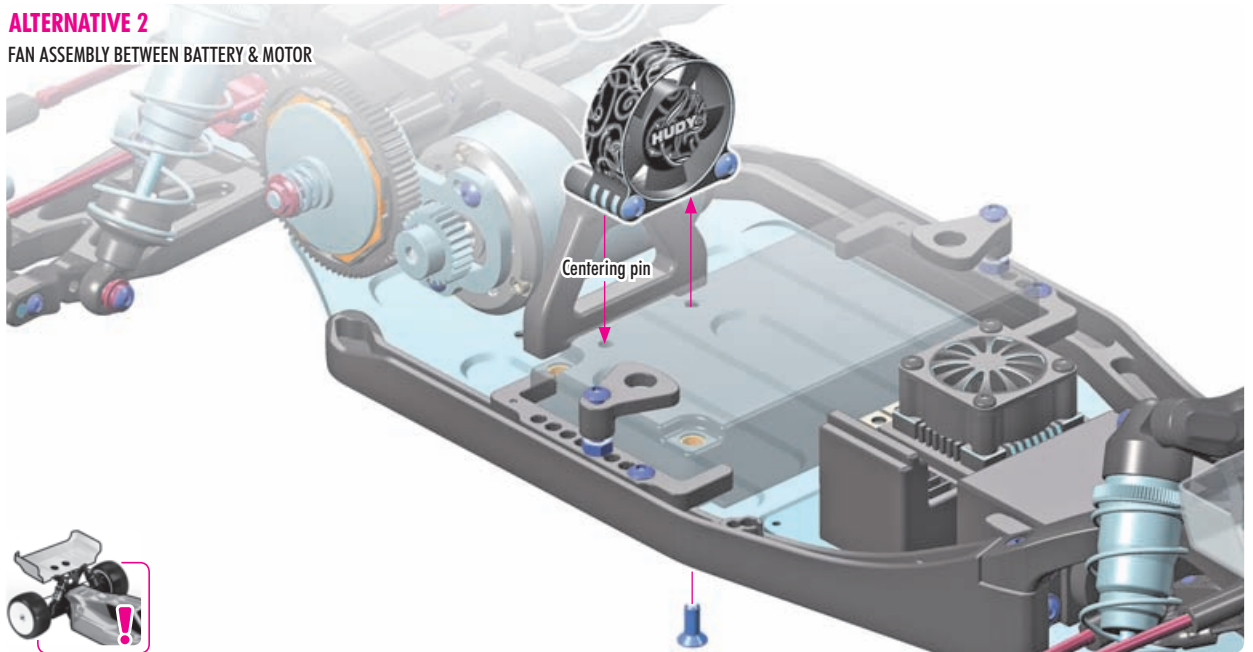



2x 903308
SFH M3x8

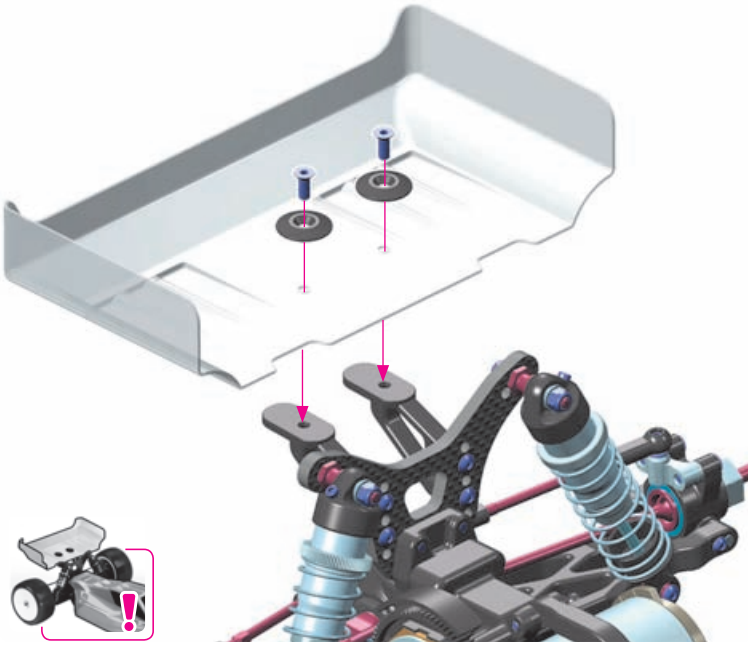

REAR WING SHIMS

#293561	SILVER	OPTION
#293561-0	ORANGE	OPTION
#293561-K	BLACK	OPTION



XRAY LEXAN REAR WINGS

#323510	1.0mm		OPTION
#323511	1.5mm		OPTION
#323513	1.0mm	RANK	OPTION
#323517	1.0mm	TEC	OPTION
#323522	Std.	LUSH	INCLUDED
#323523	Thick	LUSH	OPTION
#363510	1.0mm		OPTION
#363511	1.5mm		OPTION
#363512	2.0mm		OPTION



XRAY LEXAN CENTER FIN

#323515	1.0mm	ZAP	OPTION
---------	-------	-----	--------

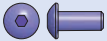

2x 902256
SH M2.5x6



2x 961025
S 2.5

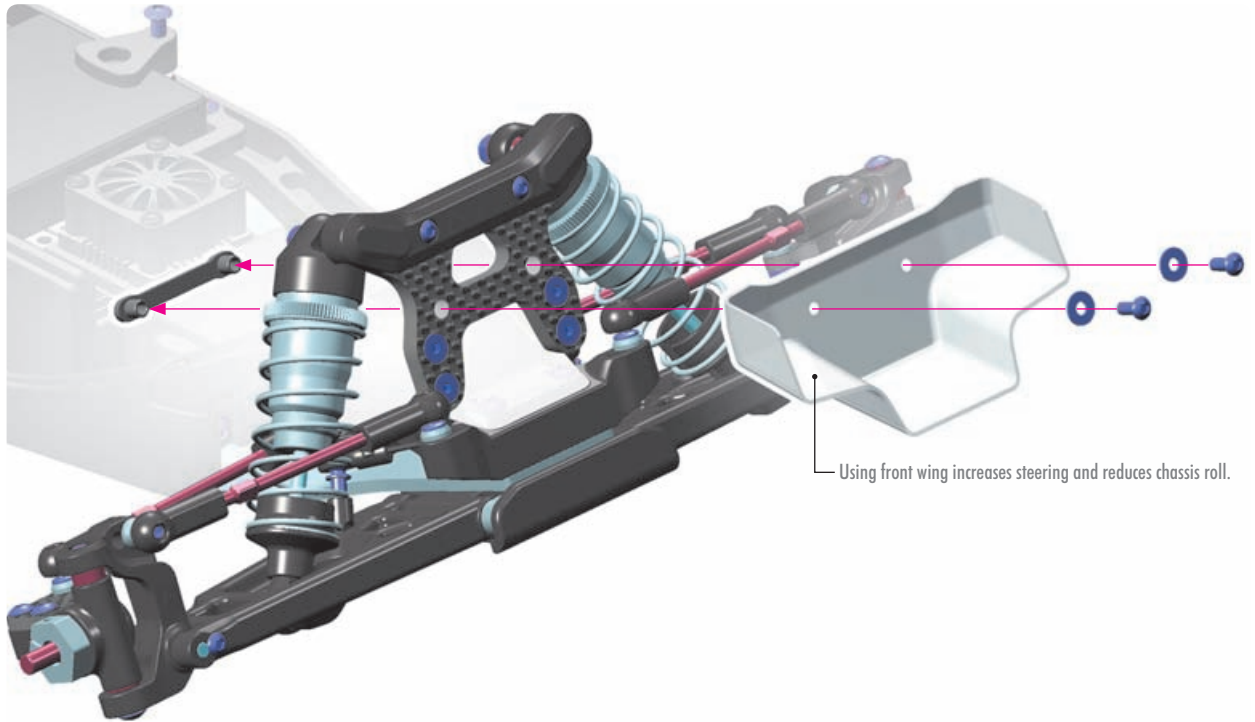

Using front wing increases steering and reduces chassis roll.



XRAY LEXAN FRONT WINGS

#323518	WIDE	INCLUDED
#323511	WIDE-RIBBED	OPTION

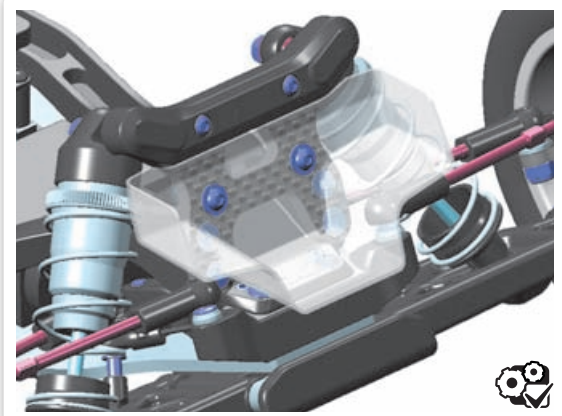
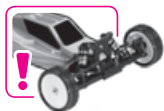

- ❶ Before cutting and making holes on the BODY, put the unpainted body on the chassis to confirm the mounting position and location for holes and cutouts. Before cutting and making holes on the WING, put the unpainted wing on the wing holders to confirm the mounting position and location for holes and cutouts.
- ❷ Before painting, wash the inside of the body with mild detergent, and then rinse and dry thoroughly.
- ❸ Mask all windows.

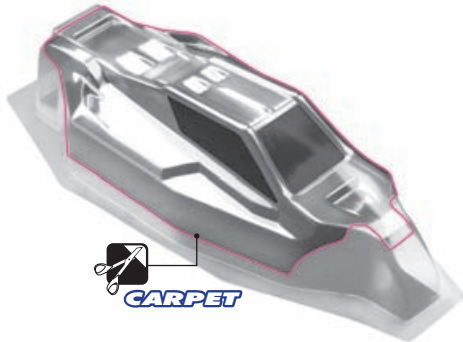
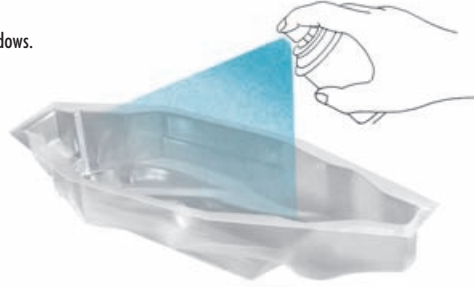

XRAY LEXAN BODY				
OPTION	#329714	0.75mm	DELTA 2D	INCLUDED
	#329715	0.50mm	DELTA 2DL	OPTION
	#329716	0.75mm	DELTA 2C	INCLUDED
	#329717	0.50mm	DELTA 2CL	OPTION



- ❹ Apply paint masks as appropriate.
- ❺ Paint the body using paints formulated for polycarbonate bodies.
- ❻ When the paint is dry, remove the masking.
- ❼ Carefully cut out the body using appropriate scissors or cutting tools.
- ❽ When you have finished cutting, peel off the external protective films.

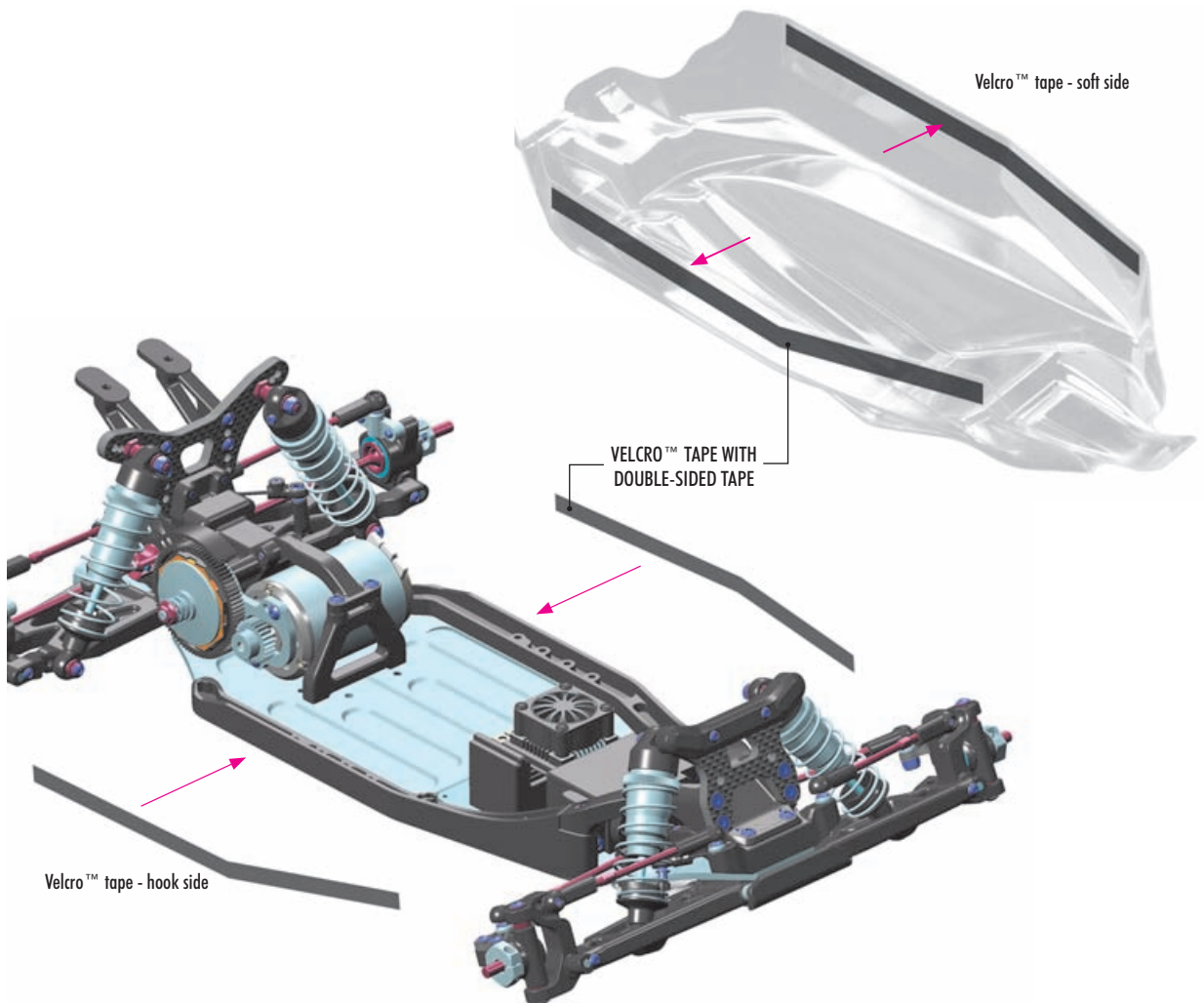



4x

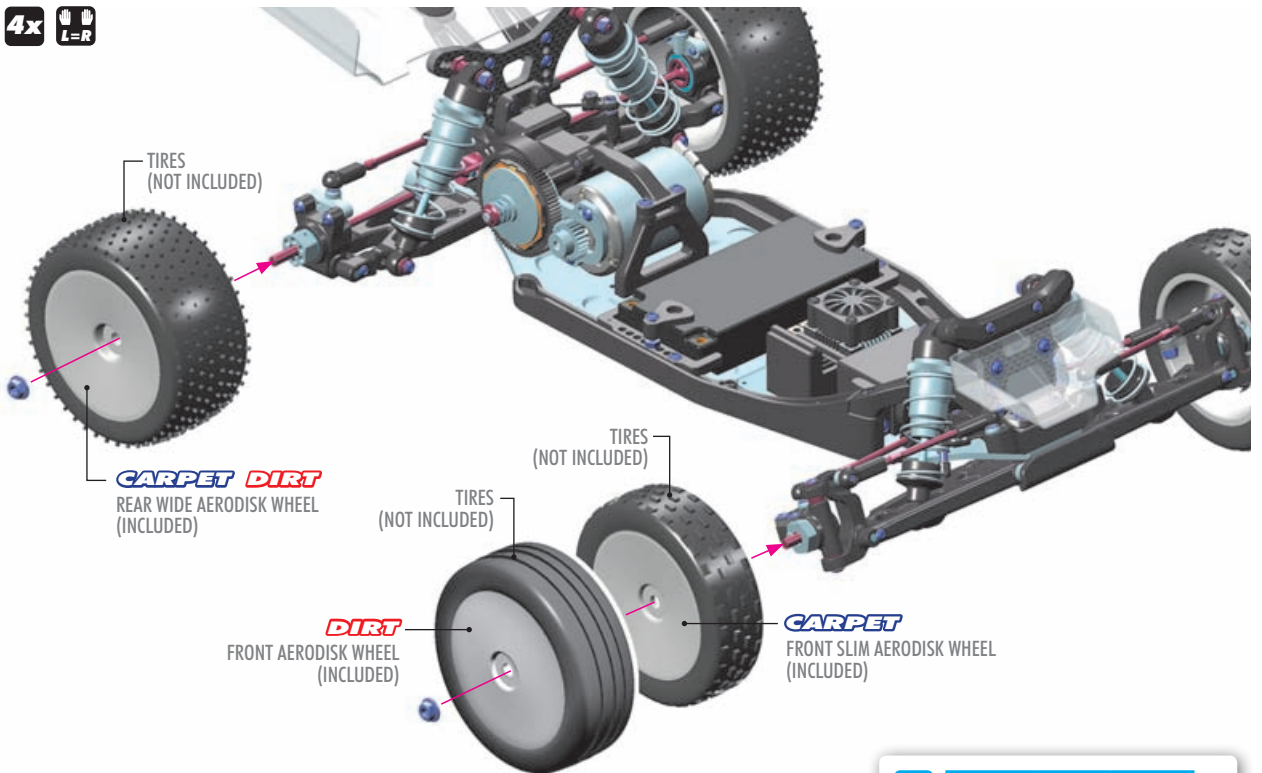

XRAY FRONT AERODISK WHEELS

#329900-M	MEDIUM	WHITE	10pcs	OPTION
#329900-H	HARD	WHITE	10pcs	OPTION
#329900-Y	HARD	YELLOW	10pcs	OPTION
#329904-M	MEDIUM	SLIM WHITE	10pcs	OPTION
#329904-Y	MEDIUM	SLIM YELLOW	10pcs	OPTION
#329910-M	MEDIUM	WHITE	2pcs	INCLUDED
#329910-H	HARD	WHITE	2pcs	OPTION
#329910-Y	HARD	YELLOW	2pcs	OPTION
#329914-M	MEDIUM	SLIM WHITE	2pcs	INCLUDED
#329914-Y	MEDIUM	SLIM YELLOW	2pcs	OPTION



ALU NUT SERRATED FLANGE

#960240	SILVER	INCLUDED
#960241-O	ORANGE	OPTION
#960241-K	BLACK	OPTION



XRAY REAR AERODISK WHEELS

#329901-M	MEDIUM	WHITE	10pcs	OPTION
#329901-H	HARD	WHITE	10pcs	OPTION
#329901-Y	HARD	YELLOW	10pcs	OPTION
#329913-M	MEDIUM	WHITE	2pcs	INCLUDED
#329913-H	HARD	WHITE	2pcs	OPTION
#329913-Y	HARD	YELLOW	2pcs	OPTION

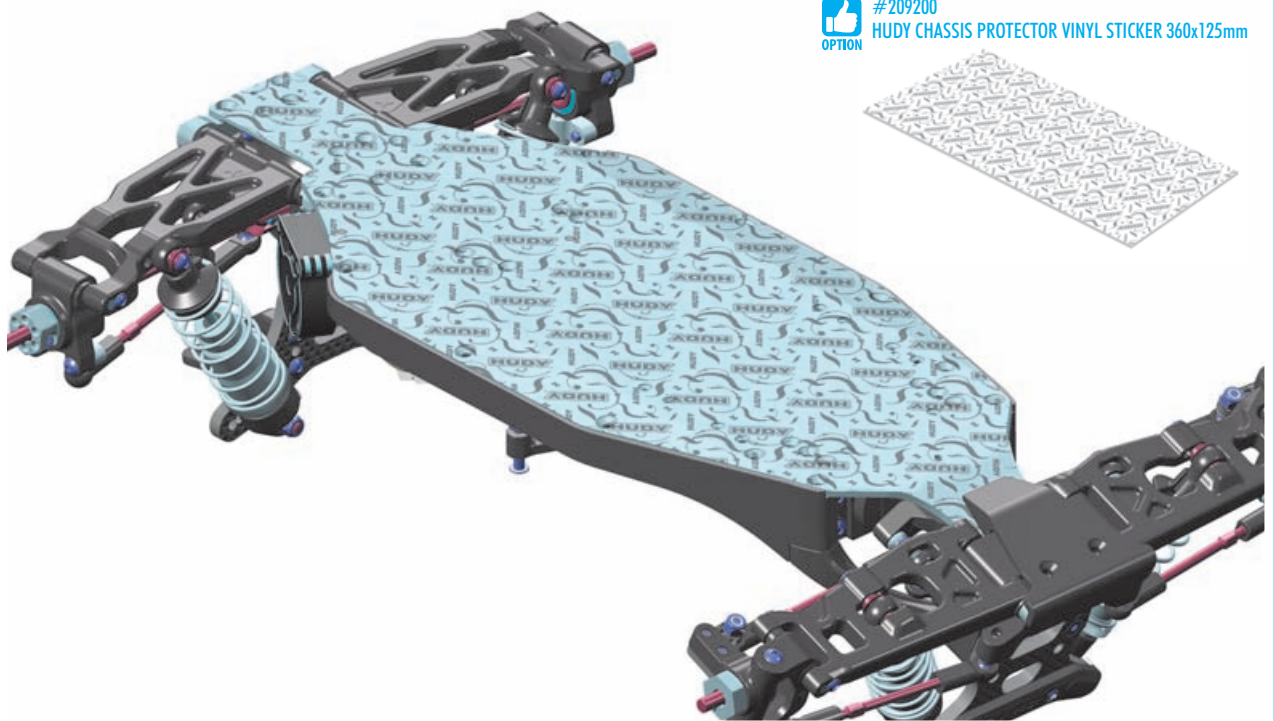

#209200

HUDY CHASSIS PROTECTOR VINYL STICKER 360x125mm

SHOCK MAINTENANCE

The most important maintenance task for keeping consistent shock performance is refilling and bleeding them correctly. If built correctly, it will not be necessary to re-build them often. Replacing warped/hard o-rings, scarred piston rods, or shaved/split/loose composite upper and lower ball joints are also important.

- For club racing, it is recommended to check the shocks for air inside before each race and only re-fill and bleed them if necessary. Before each race day, make sure you take the spring off of each shock, hold it up to your ear, and quickly compress the shock rod fully into the body while listening for any air making a "whistling" or "squishy" sound as it passes through the piston holes. If you hear any air, refill and bleed your shocks. For high-competition racing, it is recommended that the shocks be re-filled and bled before a large event.
- If building or pairing new shocks, always make sure they are the same length using a shock length measuring tool and adjust the lower ball joints as needed.
- During regular shock operation, oil naturally gets on the shock shaft and drop-by-drop slightly gets out of the shock body. Shocks should be inspected regularly after each race, and oil replaced as required.

BEARING MAINTENANCE

Ball-bearings in an off-road car must be properly maintained for smooth operation and long lifespan.

The ball-bearings are degreased and are lubricated with HUDY Bearing Oil. The following procedures are recommended to clean all of the bearings in your off-road car. For high-competition racing, we recommended doing this every 3-4 weeks, or before a major race.

- 1 Remove the seals on both sides of the bearing (if present). If the seals bend a little and you can see a kink, carefully flatten the kink out by hand.
- 2 Spray the seals with motor cleaner and blow dry with compressed air.
- 3 Spray the bearing on both sides with motor cleaner.
- 4 Spin the bearing while it is still wet to dislodge any particles with the cleaner.
- 5 Spray the bearing on both sides again.
- 6 Blow both sides of the bearing dry with compressed air to make sure particles come out.
- 7 Hold the inner part of the bearing with my left thumb/forefinger and spin it to make sure it spins free without any abnormal vibrations or sounds.
- 8 Place one drop of bearing oil into each side of the bearing.
- 9 Replace both seals at the same time by lining them up on each side of the bearing and lightly pressing them in all the way around the bearings circumference with your thumb and forefinger. DO NOT press too hard or use any type of tool, such as a wrench tip, to push the blue seals in as they will push in too far, bend and cause drag.

If you spin test the bearing after you have re-oiled and sealed it, it will not spin freely for an extended period of time. The lightest of oils may allow it to spin for 1-2 seconds. This is normal and once you have mounted the bearings in the car again, the drive train will spin freely.

Make sure you use a motor cleaner that DOES NOT leave a residue after it dries as this may cause drag and wear in the bearings.

RECOMMENDED PRODUCTS

- Use correct oil or grease to lubricate the bearings:
 - #106230 HUDY Bearing Oil
 - #106220 HUDY Bearing Grease - Standard
 - #106221 HUDY Bearing Grease - Blue
 - #106222 HUDY Bearing Grease - Red



SUSPENSION & DRIVETRAIN MAINTENANCE

- Check suspension for free movement during building and operation, and especially after running and if you have crashed the car. If the suspension DOES NOT move freely, use the appropriate HUDY Arm Reamer to clean and resize the holes of the suspension arms.
- Regularly check the drive shaft pins and if they show any wear must be immediately replaced by new pins. If the car is run with worn pins, excessive wear on the diff outdrives will result. The #106000 HUDY Drive Pin Replacement Tool (for 3mm Pins) is a compact, rugged multi-use tool set for replacing 3mm drive pins in drive shafts. Use the HUDY replacement drive shaft pins 3x12 (#106051).
- Regularly inspect and replace the pins that connect the wheel drive shafts with wheel axles. Use HUDY Graphite Grease to lubricate the drive shaft connecting joints and the diff gears.
- Pivot balls and ball-joints will naturally wear for some time and will generate play. If there is too much play the pivot balls and ball joints need to be replaced.
- If the car is run in wet conditions, apply WD-40® on all drivetrain parts before the run. After the run, clean and dry the parts again.



HUDY SPRING STEEL™

The HUDY Spring Steel™ used in the car is the strongest and most durable steel material on the RC market. While items made from HUDY Spring Steel™ are still subject to wear, the lifespan is considerably longer than any other material. As parts made from HUDY Spring Steel™ wear, the

brown color will fade (get lighter) but it will not affect the strength of the material. The brown color is only a surface treatment and if the brown color will wear the durability of the part will be still strong.

NOTE

A large, empty rectangular box with a black border, intended for a note. The box is white and occupies most of the page area below the 'NOTE' header and above the footer.

NOTE

A large, empty rectangular box with a thin black border, intended for a note or additional information.

NOTE

A large, empty rectangular box with a thin black border, occupying most of the page. It is intended for a note or comment.

EXCLUSIVE PROFESSIONAL

HUDY

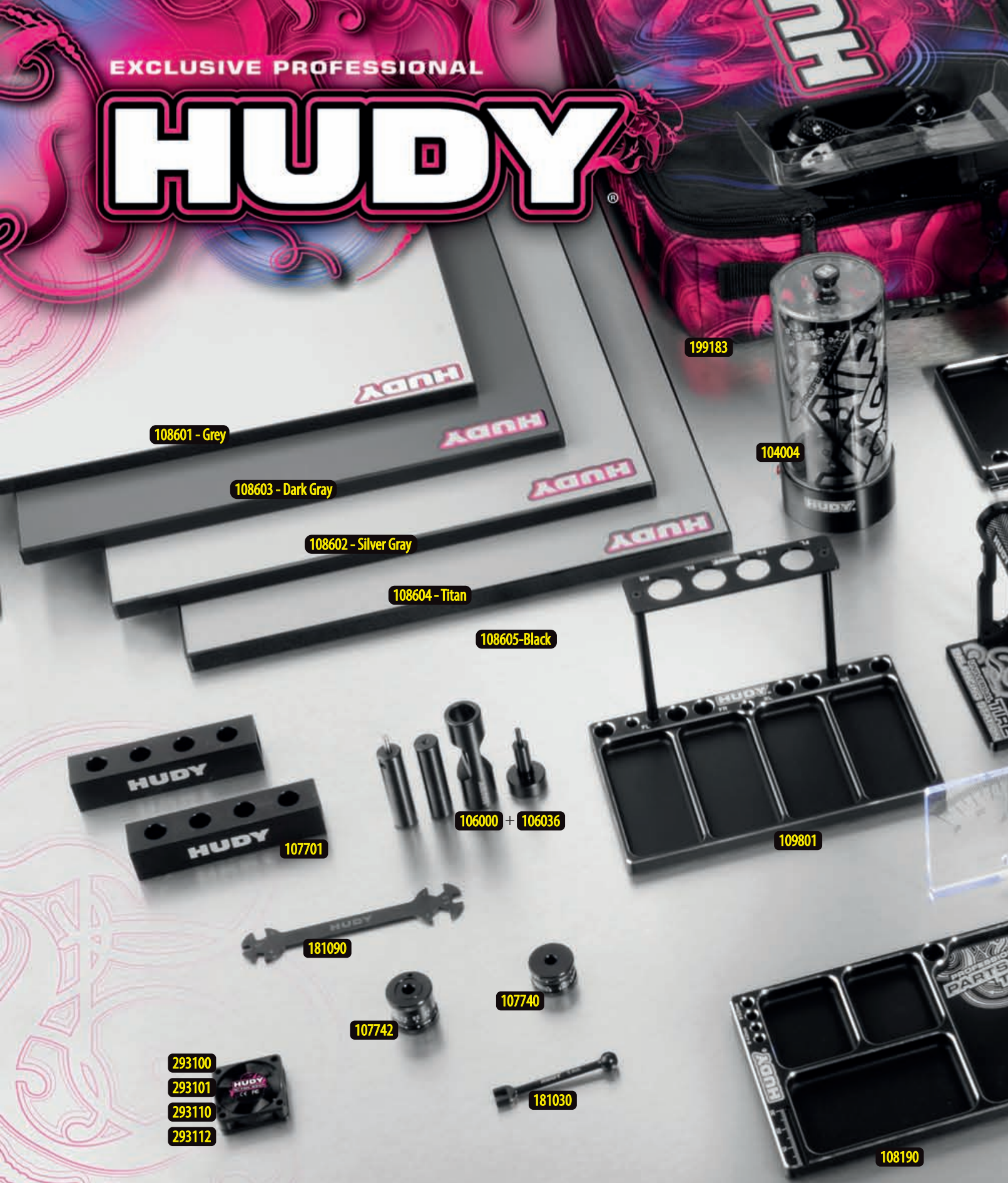

108601 - Grey

108603 - Dark Gray

108602 - Silver Gray

108604 - Titan

108605-Black

199183

104004

107701

106000 + 106036

109801

181090

107742

107740

293100

293101

293110

293112

181030

108190

- 104004 HUDY AIR VAC - VACUUM PUMP - 1/10 OFF-ROAD
- 105500 HUDY UNIVERSAL TIRE BALANCING STATION
- 105520 WHEEL ADAPTER FOR 1/10 TOURING CARS - 12MM
- 106000 HUDY DRIVE PIN REPLACEMENT TOOL (FOR 3MM PINS)
- 106036 EJECTOR PIVOT PIN & ALTERNATING PIVOT 2.5MM FOR #106000
- 107090 HUDY BEARING CHECKING TOOL
- 107601 LIMITED EDITION - REAMER FOR BODY Ø-9MM + COVER - SMALL
- 107701 CHASSIS DROOP GAUGE SUPPORT BLOCKS 20MM FOR 1/8 - LW(2)
- 107740 HUDY ADJUSTABLE RIDE HEIGHT GAUGE 14-20MM
- 107742 HUDY ADJUSTABLE RIDE HEIGHT GAUGE 20-30MM
- 107855 HUDY PIT LED
- 107880 CHASSIS BALANCING TOOL (2)

- 108160 HUDY 1/10 OFF-ROAD CAR STAND - V2
- 108190 HUDY ALU TRAY FOR PARTS
- 108601 FLAT SET-UP BOARD FOR 1/10 OFF-ROAD - LIGHTWEIGHT - GREY
- 108602 FLAT SET-UP BOARD FOR 1/10 OFF-ROAD - LIGHTWEIGHT - SILVER GRAY
- 108603 FLAT SET-UP BOARD FOR 1/10 OFF-ROAD - LIGHTWEIGHT - DARK GRAY
- 108604 FLAT SET-UP BOARD FOR 1/10 OFF-ROAD - LIGHTWEIGHT - TITAN
- 108605 FLAT SET-UP BOARD FOR 1/10 OFF-ROAD - LIGHTWEIGHT - BLACK
- 108901 HUDY SET-UP STATION FOR 1/10 OFF-ROAD CARS
- 108960 ALU NUT FOR 1/10 OFF-ROAD SET-UP SYSTEM (4)
- 109801 HUDY ALU TRAY FOR 1/10 OFF-ROAD DIFF & SHOCKS
- 109840 HUDY ALU TRAY FOR 1/10 OFF-ROAD DIFF ASSEMBLY
- 109860 HUDY ALU TRAY FOR SET-UP SYSTEM

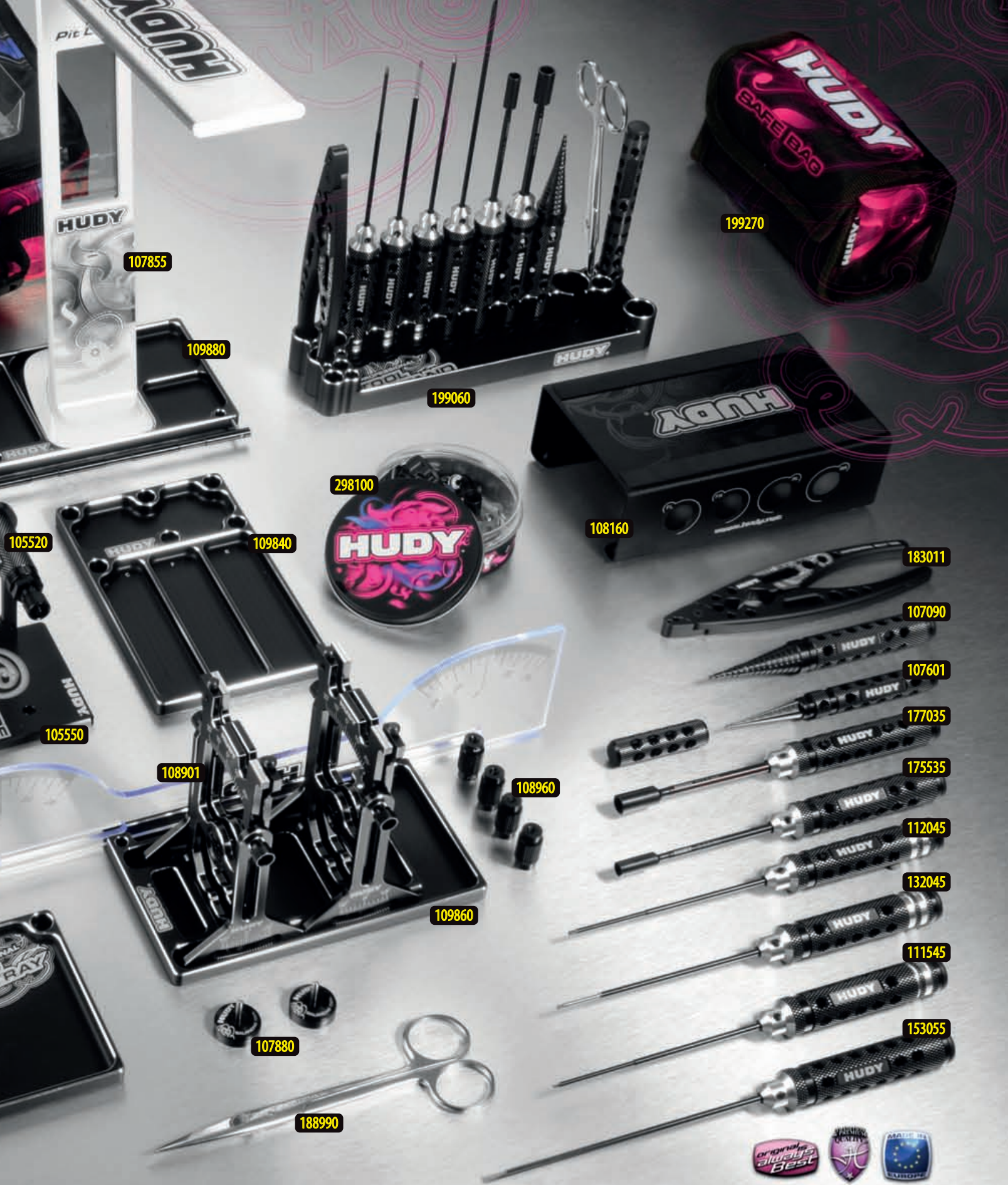

109880 HUDY ALU TRAY FOR ACCESSORIES & PIT LED
 111545 LIMITED EDITION - ALLEN WRENCH # 1.5MM
 112045 LIMITED EDITION - ALLEN WRENCH # 2.0MM
 132045 LIMITED EDITION - ALLEN WRENCH + BALL REPL. TIP # 2.0MM
 153055 LIMITED EDITION - SLOTTED SCREWDRIVER # 3.0MM - LONG
 175535 LIMITED EDITION - SOCKET DRIVER # 5.5MM
 177035 LIMITED EDITION - SOCKET DRIVER # 7.0MM
 181030 HUDY SPRING STEEL TURNBUCKLE WRENCH 3 MM
 181090 HUDY SPECIAL TOOL FOR TURNBUCKLES & NUTS
 183011 HUDY PROFESSIONAL MULTI TOOL

188990 HUDY PROFESSIONAL BODY SCISSORS
 199060 HUDY ALU TOOL STAND
 199183 HUDY CAR BAG - 1/10 OFF-ROAD
 199270 HUDY LIPO SAFETY BAG
 298100 HUDY TIN ROUND BOX 80X30MM
 293100 HUDY ALU RC FAN 30MM - BOTTOM MOUNT 2 HOLE
 293101 HUDY ALU RC FAN 30MM - SIDE MOUNT 2 HOLE
 293110 HUDY BRUSHLESS RC FAN 30MM - WITH EXTERNAL SOLDERING TABS
 293112 HUDY BRUSHLESS RC FAN 30MM - WITH INTERNAL SOLDERING TABS

For more information about tools, set-up equipment and accessories suitable for your car please visit:

www.hudy.net

www.teamxray.com

XRAY EUROPE

XRAY, K VÝSTAVISKU 6992, 91101 TRENCIN, SLOVAKIA, EUROPE
PHONE: +421-32-740 11 00, FAX: +421-32-740 11 09, info@teamxray.com

XRAY USA

RC AMERICA, 2030 Century Center Blvd #15, Irving, TX 75062, USA
PHONE: 214-744-2400, FAX: 214-744-2401, xray@rcamerica.com



/TeamXray



/TeamXray



/TeamXray



/XrayRacing



/+TeamXrayRC