

Driver: \_\_\_\_\_  
Date: \_\_\_\_\_

Track: \_\_\_\_\_  
Event: \_\_\_\_\_

## FRONT

Ride Height:	
Camber:	
Toe:	
Anti-Roll Bar	
Size:	
Gap:	
Ackermann	
Orientation	<input type="radio"/> <input checked="" type="radio"/> <input type="radio"/>
Drive Shaft:	
Chassie Brace:	
Hex:	

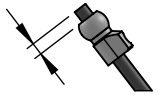
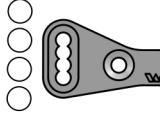
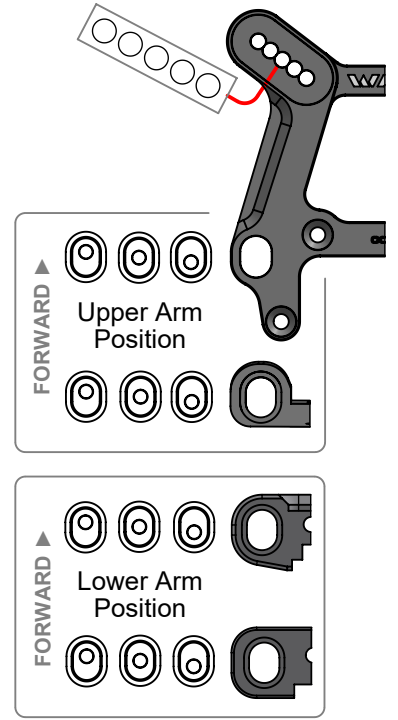
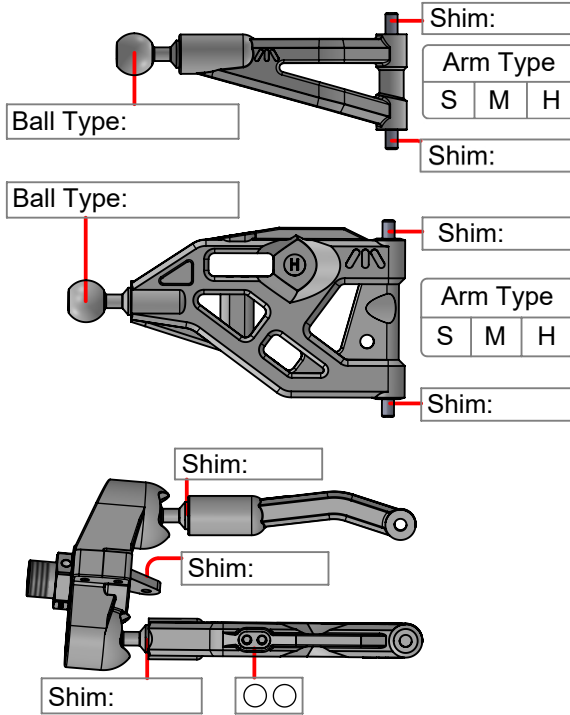

## REAR

Ride Height:	
Camber:	
Toe:	
Anti-Roll Bar	
Size:	
Gap:	
Drive Shaft:	
Chassie Brace:	
Hex:	

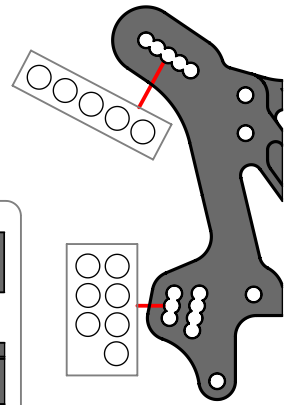
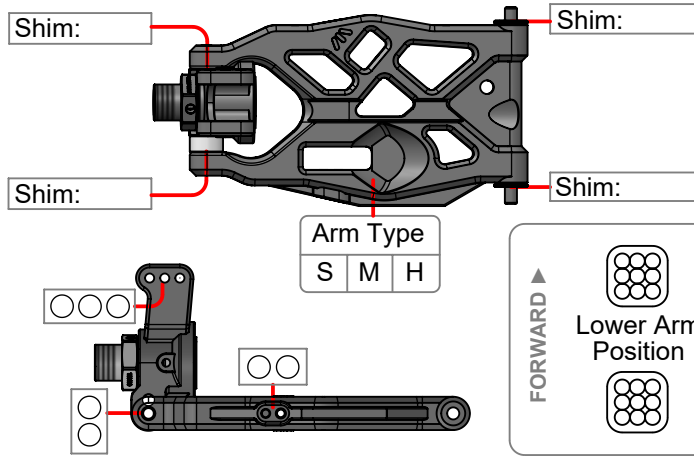

## SHOCKS

	Front	Rear
Piston:		
Membrane:		
Oil:		
Spring:		
Rebound:		
Free Length:		

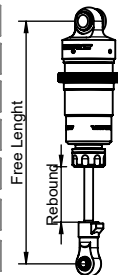

## DIFFERENTIAL

	Front	Center	Rear
Case Mat.:			
Oil:			
Crown Gear:			
Clutch Bell:		Spur Gear	
Shoe:		Spring	

## GEARING

## TYRES

	Front	Rear
Brand:		
Pattern:		
Insert:		
Wheels:		
Compound:		

## ENGINE

Type:	
Muffler:	
Manifold:	
Plug:	

## BODY & WING

Body:	
Wing:	
Wing Height:	
Gap to tower:	

## NOTES / OPTIONALS

\_\_\_\_\_

\_\_\_\_\_

\_\_\_\_\_

\_\_\_\_\_

\_\_\_\_\_

## TRACK

Size :	
Traction:	
Surface:	

Total Vehicle Weight: \_\_\_\_\_