

FIREBOLT RM

1/10 RWD ELECTRIC COMPETITION OFFROAD BUGGY CAR KIT



SETUP SHEET

DRIVER _____	DATE _____
TRACK _____	RESULT _____
COMPOSITION _____	INDOOR OUTDOOR _____
SURFACE BUMPY SMOOTH _____	TEMP. _____
GRIP CONDITION HI MED LOW _____	HUMIDITY DRY WET _____

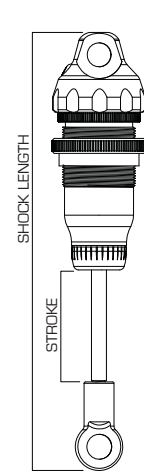
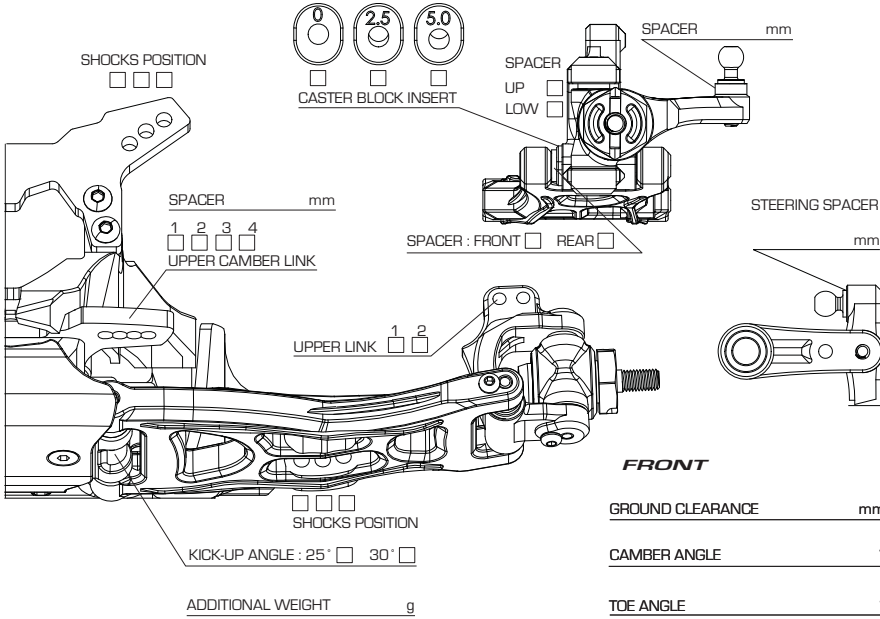

FRONT

SHOCK LENGTH _____ mm

STROKE _____ mm

PISTON _____ / OTHERS _____

OIL _____

SPRING _____

LIMITERS _____ mm

REBOUND _____ %

NOTES _____

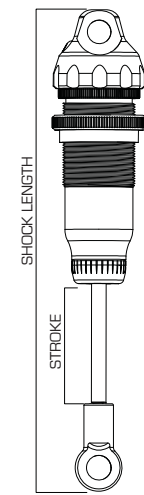
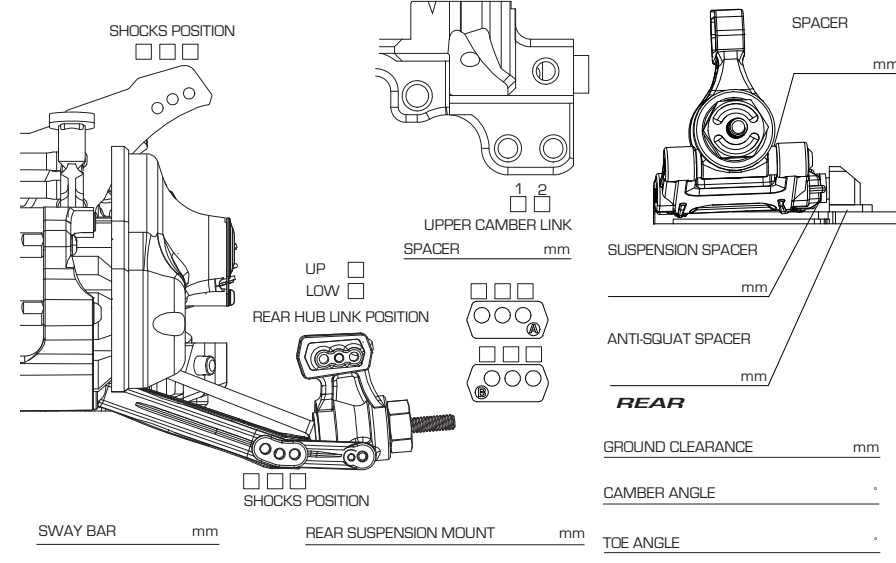

REAR

SHOCK LENGTH _____ mm

STROKE _____ mm

PISTON _____ / OTHERS _____

OIL _____

SPRING _____

LIMITERS _____ mm

REBOUND _____ %

NOTES _____

DIFFERENTIAL

DIFFERENTIAL TYPE : BALL GEAR

SETTING : _____

OIL : _____

BATTERY POSITION

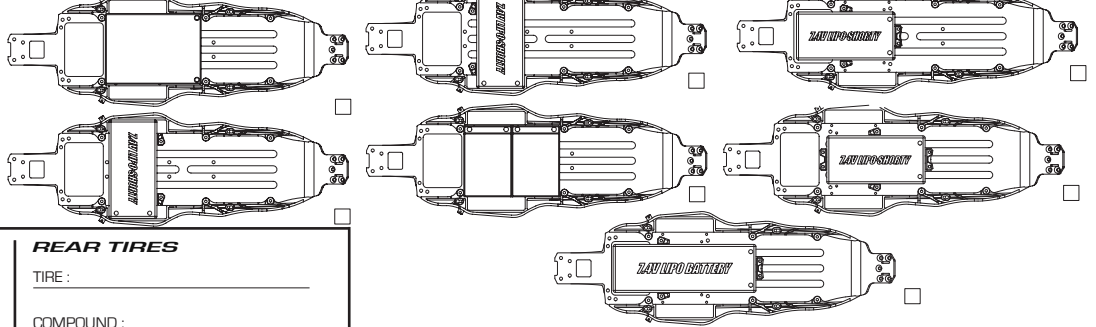

FRONT TIRES

TIRE : _____

COMPOUND : _____

INSERT : _____

WHEEL : _____

NOTES : _____

REAR TIRES

TIRE : _____

COMPOUND : _____

INSERT : _____

WHEEL : _____

NOTES : _____

MOTOR : _____ ROTOR : _____ TIMING : _____

SPUR : _____ T PINION : _____ T RATIO : _____

ESC : _____ SETUP : _____ BATTERY : _____

STEERING EXPO _____ BRAKE E.P. _____ THROTTLE EXPO _____

BODY : _____ WING : _____ ANGLE : 6° 8° 10°