

Name: *Ian Cameron*

Date: *03-14-2015* Event/Track: *Sparks Park St Patty day race*

Track Conditions: Outdoor Indoor Wet Dry High Bite Low Bite Rough

Smooth Hard Packed Loose/Loamy Blue Groove

Bumpsteer/Ackerman/Servo Saver/Steering Stop:

<p># washers 4 over 0 under</p> <p>ballstud <input type="checkbox"/> <input checked="" type="checkbox"/></p>	<p># washers 4 over 0 under</p> <p>ballstud <input type="checkbox"/> <input checked="" type="checkbox"/></p>	<p><input type="checkbox"/> front <input checked="" type="checkbox"/> middle <input type="checkbox"/> rear</p>
--	--	--

Front End:

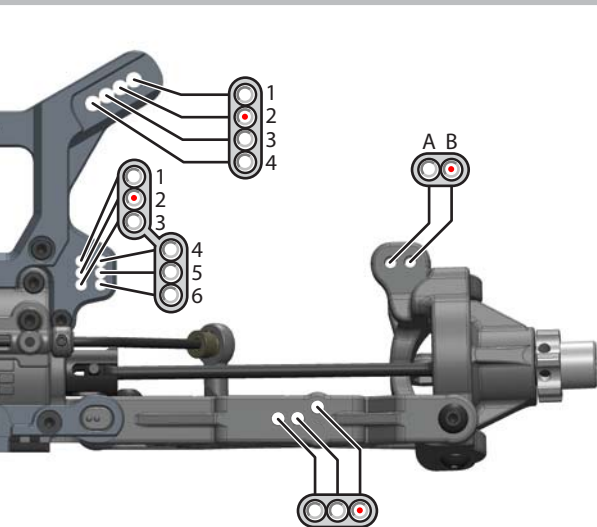

Front Outer (Sweep)

1.0F 0.5F 0.0 0.5R 1.0R

Front Inner (Kick Up)

10.0° 10.5° 11.0° 11.5° 12.0°

Rear End:

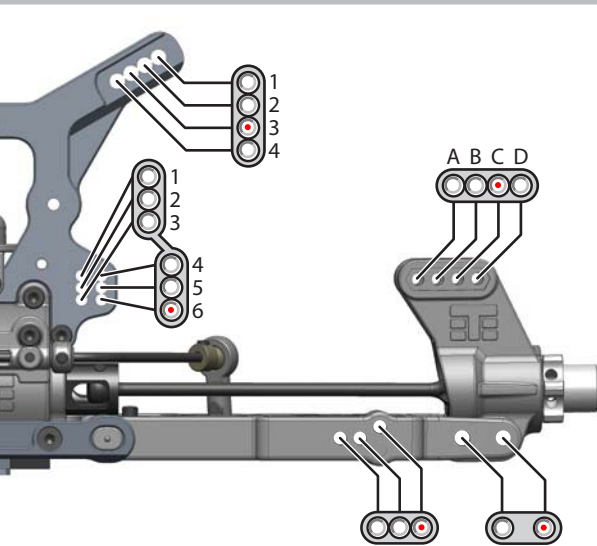

Rear Outer (Toe In)

2.5° 3.0° 3.5° 4.0° 4.5°

Rear Inner (Anti-Squat)

3.0° 2.5° 2.0° 1.5° 1.0°

of turns from fully tightened *tight*

washers 3

Suspension:

	FRONT	REAR
RIDE HEIGHT:	<i>37</i>	<i>37</i>
TOE (in/out):	<i>1out</i>	
CAMBER:	<i>-2</i>	<i>-2</i>
CASTER:	<i>10</i> Deg°	
SHOCK LENGTH (DROOP):	<i>122</i>	<i>136</i>
SWAY BAR:	<i>0.0</i>	<i>2.6</i>

NOTES: *no front swaybar*

Body/Wing:

BODY:	<i>stock</i>
WING:	<i>stock</i>

(DOWNFORCE POSITION)

Wheelbase:

3 mm / FRONT

2 mm / REAR

large 2mm small 1mm

Notes:

+1.5 rear hanger

Shocks:

	FRONT	REAR
STD/EMUL/VENT:	<i>vent</i>	<i>vent</i>
PISTON:	<i>8x1.3</i>	<i>8x1.3</i>
OIL:	<i>42.5 ae</i>	<i>35 ae</i>
BLADDER:	<i>stock</i>	<i>stock</i>
REBOUND:	<i>0</i> %	<i>0</i> %
SPRING:	<i>green</i>	<i>Orange</i>

NOTES: *Tekno pistons and springs.*

Tires / Wheels:

	FRONT	REAR
BRAND:	<i>HB</i>	<i>HB</i>
TREAD:	<i>Megabytes</i>	<i>Megabytes</i>
COMPOUND:	<i>pink</i>	<i>pink</i>
INSERT:	<i>AKA Red</i>	<i>AKA Red</i>
WHEEL:	<i>Proline</i>	<i>Proline</i>

NOTES:

Differential Oil:

	FRONT	CENTER	REAR
	<i>10</i>	<i>20</i>	<i>5</i>

NOTES:

Equipment:

BATTERY:	<i>Trakpower 6700 90c</i>
ESC:	<i>Tekin RX8 Gen 2</i>
MOTOR:	<i>Tekin Gen2 T8 1700kv</i>
RADIO:	<i>M12</i>
SERVO(s):	<i>Savox sb2271</i>

NOTES:

Drivetrain:

PINION/BELL:	<i>21</i>	(teeth)
SPUR GEAR:	Metal <input type="checkbox"/> Plastic <input type="checkbox"/>	
BRAKES:	Mech <input type="checkbox"/> Motor <input type="checkbox"/>	
TRAKTION DRIVE:	Y/N / Springs	

NOTES: