

Name: _____ **Date:** _____ **Event:** _____
Track: Indoor Outdoor **Size:** Small Medium Large **Traction:** Low Med High
Surface: Smooth Bumpy Rutted **Type:** Dirt Clay Carpet AstroTurf
Condition: Dusty Dry Wet Muddy

Bumpsteer/Ackermann/Steering Stop:

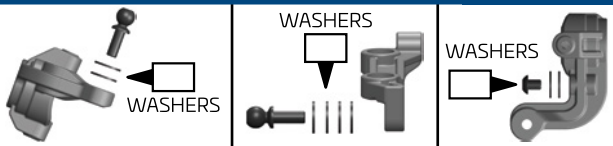

Front End:

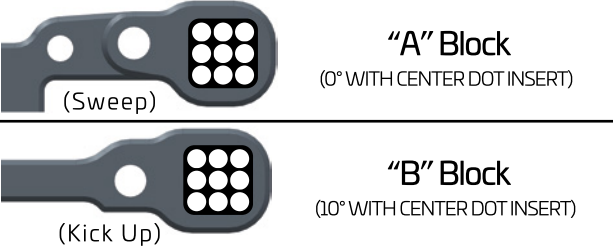
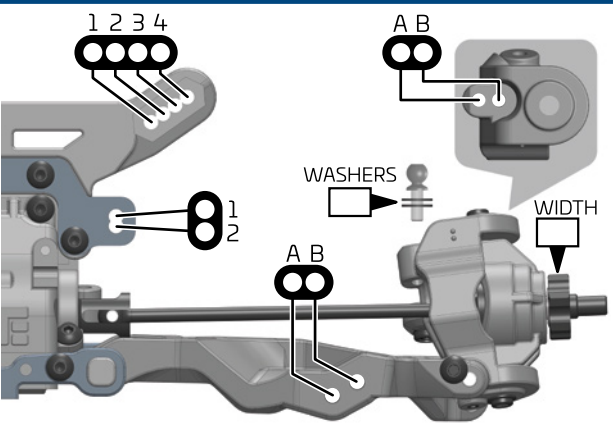

Rear End:

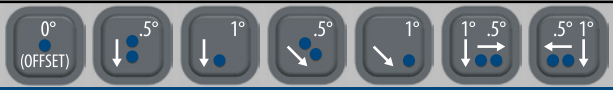
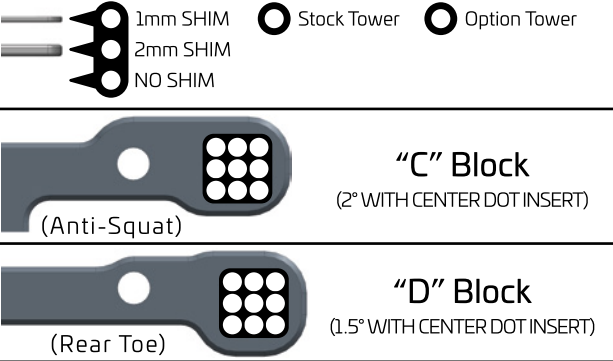
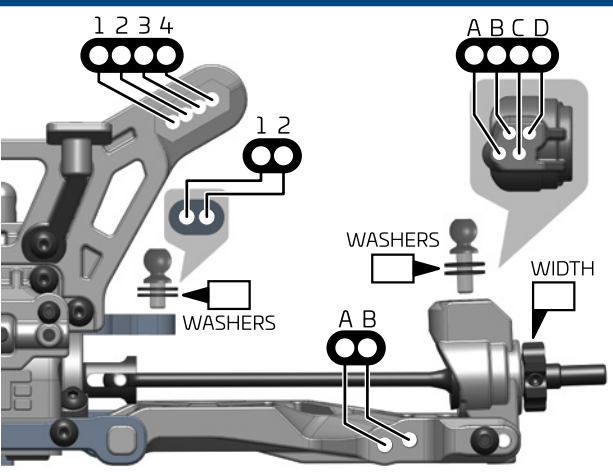

Suspension:

	FRONT	REAR
RIDE HEIGHT		
CAMBER		
CASTER		
SWEEP		
KICK UP		
ANTI-SQUAT		
TOE (in/out)	(per side)	(per side)
SWAY BAR		
SHOCK LENGTH (DROOP)		

Shocks:

	FRONT	REAR
OIL		
BRAND		
PISTON		
SPRING		
REBOUND	%	%
BUILD		

NOTES:

Tires / Wheels:

	FRONT	REAR
BRAND/TREAD		
COMPOUND		
INSERT		
WHEEL		

NOTES:

Body/Wing:

DOWNFORCE SETTINGS

Shim/Direction: 3° (left), 15° (left), 0°, 15° (right), 3° (right)

Total Wing Angle: 9°, 7.5°, 6°, 4.5°, 3°

WING POSITION SETTINGS

(rear) (front)

Differential Oil:

FRONT	CENTER	REAR

Electronics:

ESC:	
BATTERY:	
MOTOR:	
RADIO:	
SERVO:	

Wheelbase/Axle Sweep:

Front Arm

front rear

large 1mm small .5mm

MUST = 2mm TOTAL

Rear Arm

front rear

large 1mm small .5mm

MUST = 1.5mm TOTAL

Drivetrain:

PINION/SPUR	
-------------	--

Chassis Braces:

Short Rear Long Rear

Notes:
