

Track Conditions

Composition: Astroturf Carpet Clay Dirt Grass Soft Dirt _____

Traction: Low Medium High Size: Small Medium Large Environment: Indoor Outdoor

Condition: Dry Dusty Wet Muddy Surface: Smooth Bumpy Rutted

Front Suspension

BUMPSTEER: _____ ACKERMANN: _____



STEERING STOP: _____

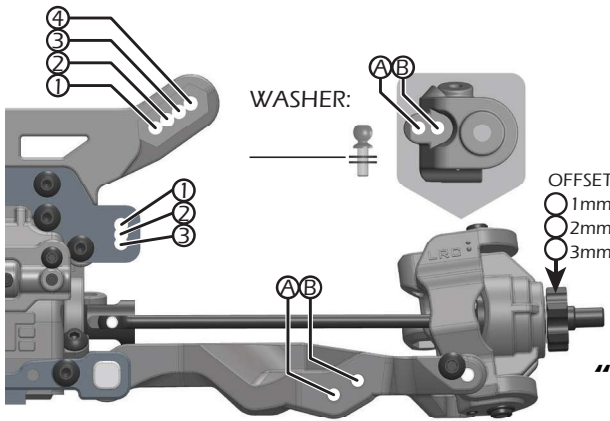

WASHER: _____

OFFSET
 1mm
 2mm
 3mm

"A" Block
 (Arm Sweep)
 (0° with center dot inserts)

"B" Block
 (Kick-Up)
 (10° with center dot inserts)

TOE: _____ CAMBER: _____

CASTER: _____ SWEEP: _____

DROOP: _____ KICK-UP _____

RIDE HEIGHT: _____

Shocks

OIL: _____

PISTON: _____

SPRING: _____

STROKE: _____

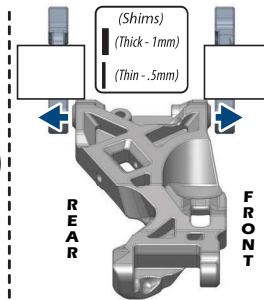

REAR FRONT

Differential Oil

FRONT: _____

CENTER: _____

REAR: _____

Drivetrain

PINION / SPUR: _____ / _____

Equipment

MOTOR: _____

ESC: _____

BATTERY: _____

RADIO: _____

SERVO: _____

Chassis Braces

REAR-SHORT REAR-LONG

Tires & Wheels

TIRES: _____

COMPOUND: _____

INSERT: _____

WHEELS: _____

NOTES: _____

Body & Wing

BODY: _____

WING: _____

Notes

Rear Suspension

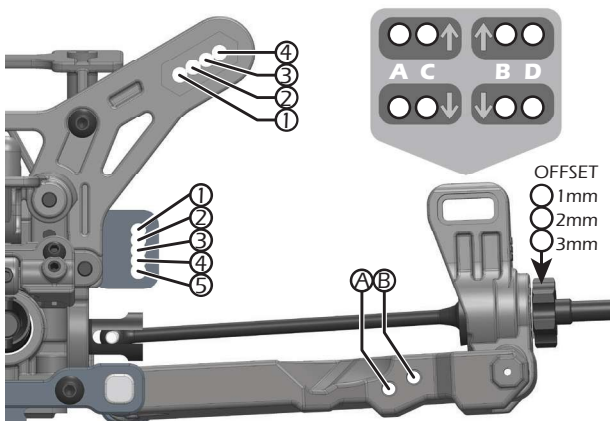

"C" Block
 (Anti-Squat)
 (2° with center dot inserts)

"D" Block
 (Rear Toe)
 (2° with center dot inserts)

TOE: _____ CAMBER: _____

RIDE HEIGHT: _____

DROOP: _____

ANTI-SQUAT: _____

SWAY BAR: _____

Shocks

OIL: _____

PISTON: _____

SPRING: _____

STROKE: _____

Rear hub / Wheelbase

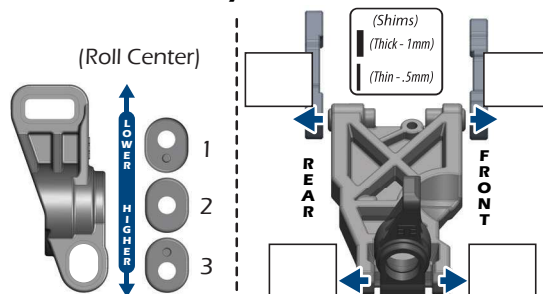

(Roll Center)

(Shims)
 (Thick - 1mm)
 (Thin - .5mm)

Wing

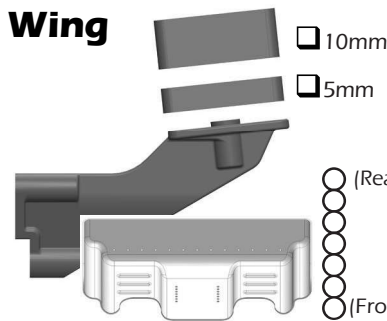

10mm

5mm

(Rear) (Front)