

Name: _____
 Date: _____
 Track: _____
 Race Time: _____

Diff. Oil
 Front: _____
 Center: _____
 Rear: _____

Track Conditions
 Size: Open Med. Tight
 Traction: High Med. Low
 Surface: Smooth Med. Bumpy

Tire
 Front Type: _____ Rear Type: _____
 Foam: _____ Foam: _____

Electric System
 ESC Type: _____ Motor Gear/Spur Gear: _____
 Motor Type: _____ Battery Type A: Standard Pack _____
 B: Shorty Pack _____

Front Suspension

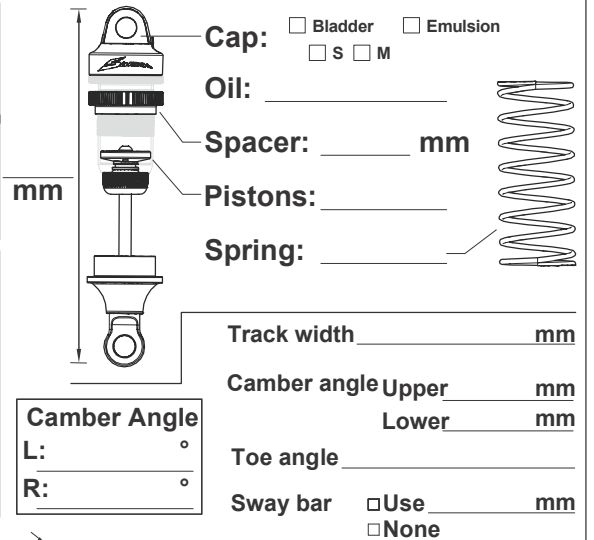
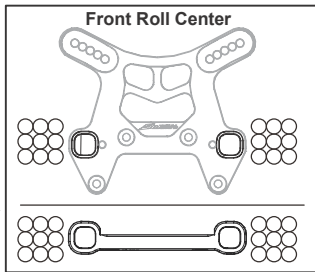
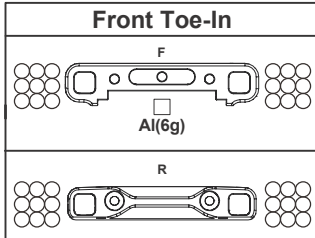
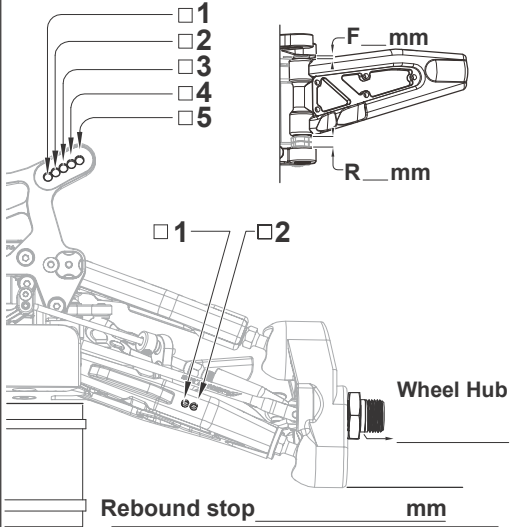

Rear Suspension

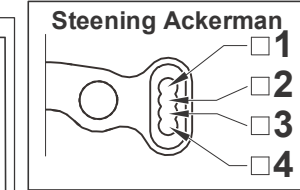
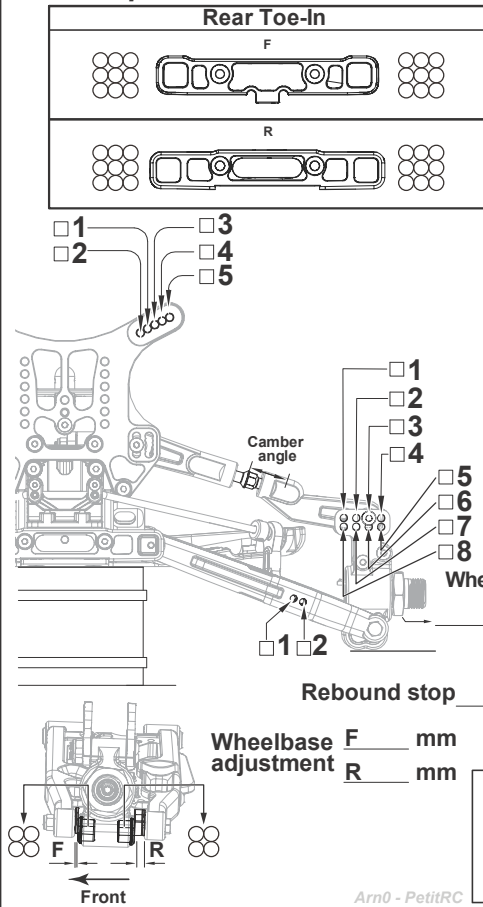

Body: _____
 Wing: _____

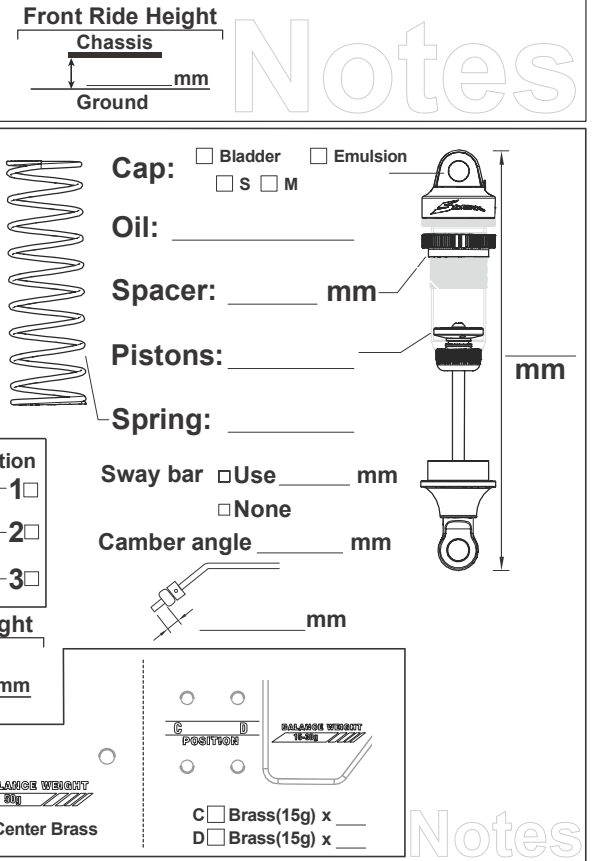
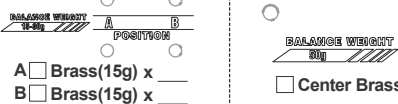
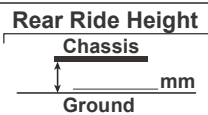
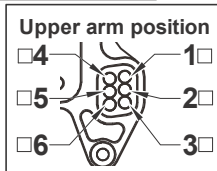
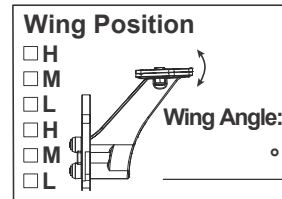

Option Parts List

Front Upper Arm
 Hard Soft
 Carbon Cover _____ mm

Front Lower Arm
 Hard Medium Soft
 Carbon Cover _____ mm

Rear Lower Arm
 Hard Medium Soft
 Carbon Cover _____ mm