

Diff. Oil

Front: _____
 Center: _____
 Rear: _____

Track Conditions

Size: Open Med. Tight
 Traction: High Med. Low
 Surface: Smooth Med. Bumpy

Tire

Front Type: _____
 Rear Type: _____
 Foam: _____
 Foam: _____

Engine

Type: _____ Muffler: _____
 Gasket: _____ mm Fuel: _____
 Plug: _____

Clutch

Clutch shoes: _____
 Spring: _____ mm
 Clutch bell / Spur gear: _____

Front Suspension

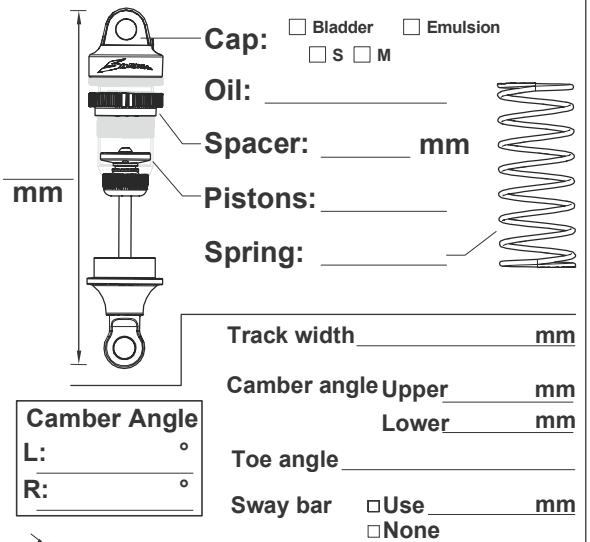
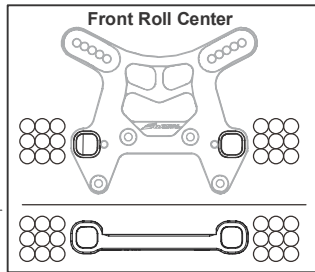
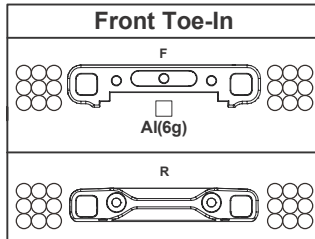
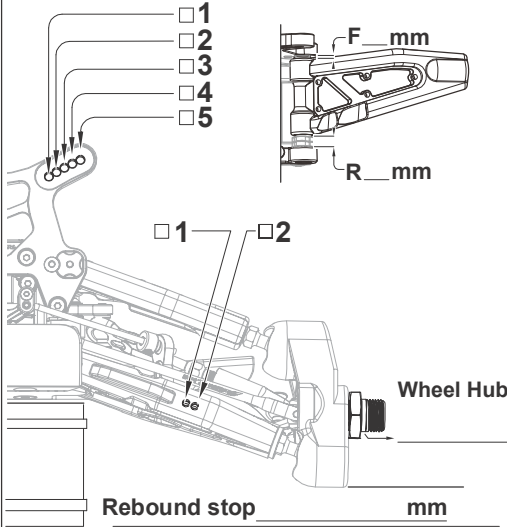

Rear Suspension

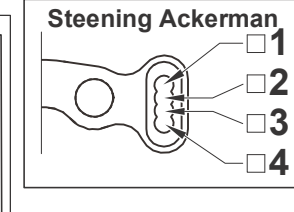
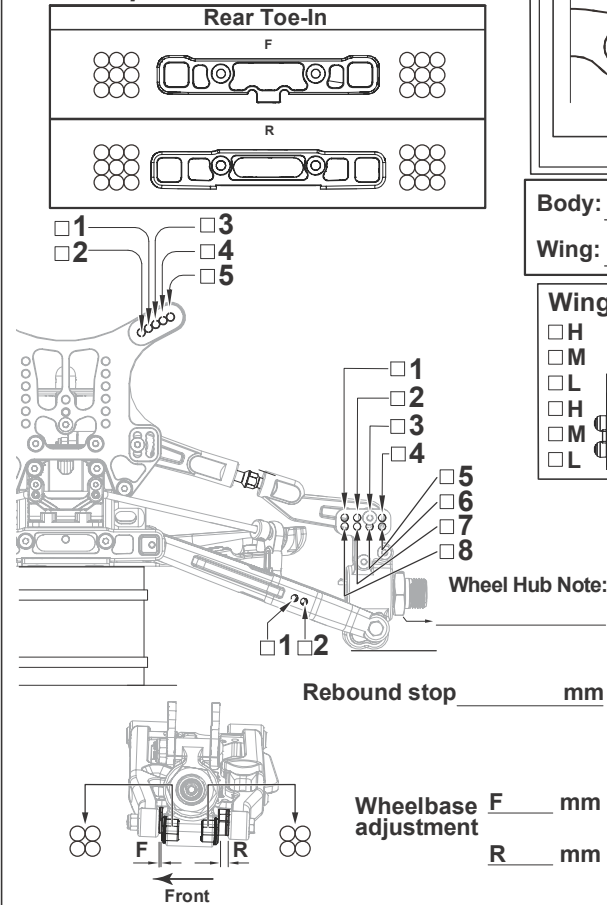

Body: _____
 Wing: _____

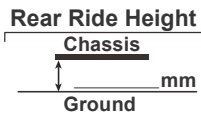
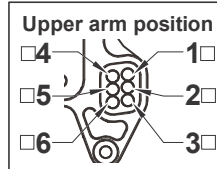
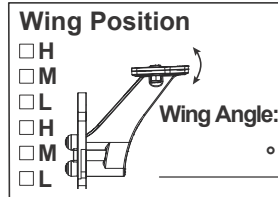

- A Brass(15g) x _____
 B Brass(15g) x _____
 C Brass(15g) x _____

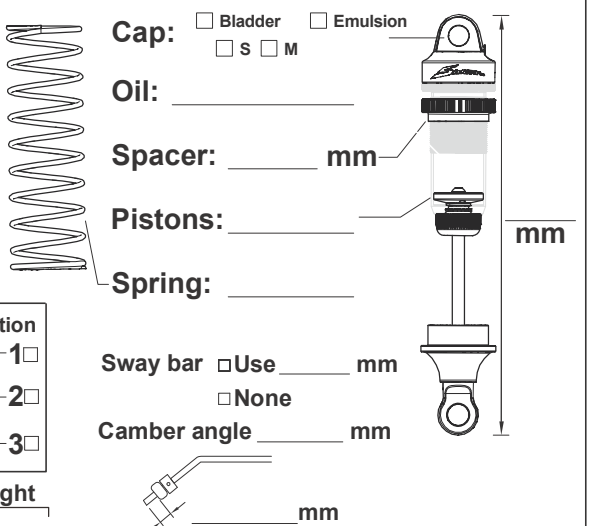
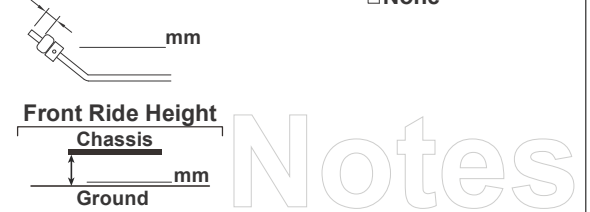

Option Parts List

Front Upper Arm

Hard Soft

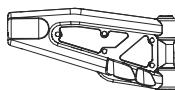

Carbon Cover _____ mm

Front Lower Arm

Hard Medium Soft

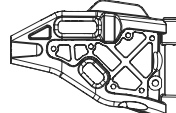

Carbon Cover _____ mm

Rear Lower Arm

Hard Medium Soft

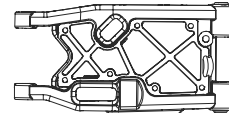

Carbon Cover _____ mm

Notes

Notes