

Name: Ashley Pattison
Date: 27/09/2020
Track: Nene Valley

Diff. Oil
Front: 10K
Center: 7K
Rear: 3K

Track Conditions
Size: Open Med. Tight
Traction: High Med. Low
Surface: Smooth Med. Bumpy

Tire
Front Type: Sch Mini Pins Rear Type: Sch Mini Pins
Foam: James Foam: James

Engine
Type: Reds Racing 721 Corsa Muffler: 2143/M
Gasket: _____ mm Fuel: Shoot Fuel
Plug: TS3

Clutch
Clutch shoes: _____
Spring: _____ mm
Clutch bell / Spur gear: 13/46

Front Suspension

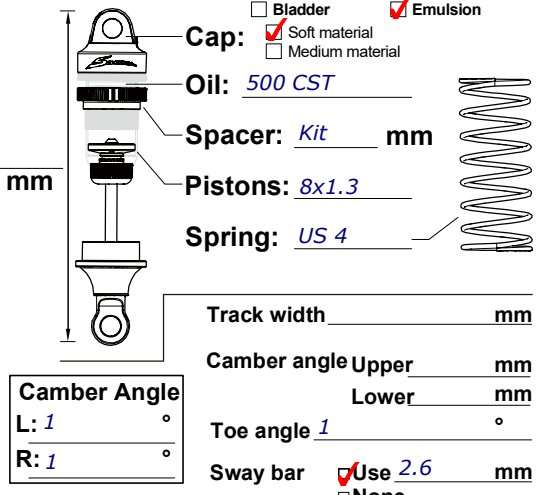
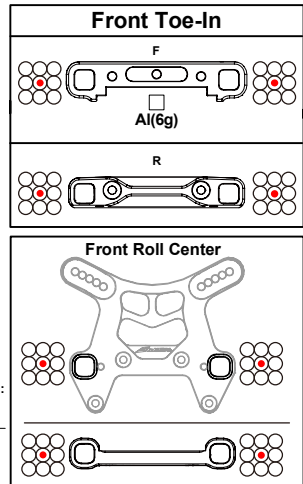
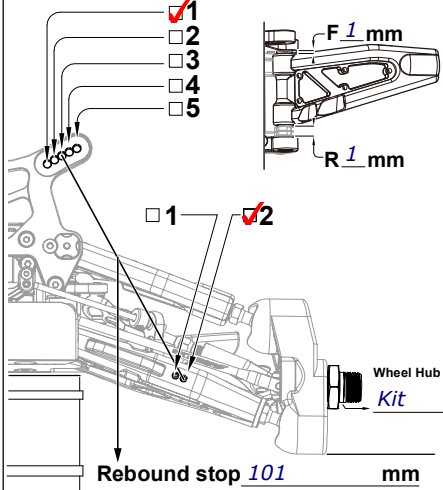

Rear Suspension

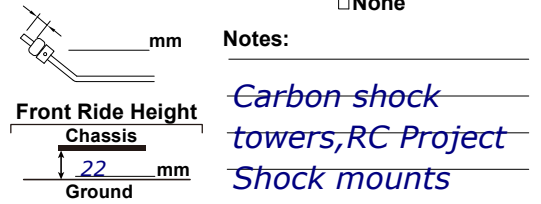
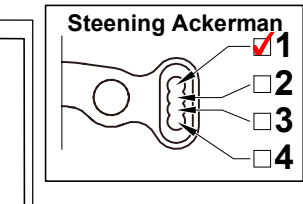
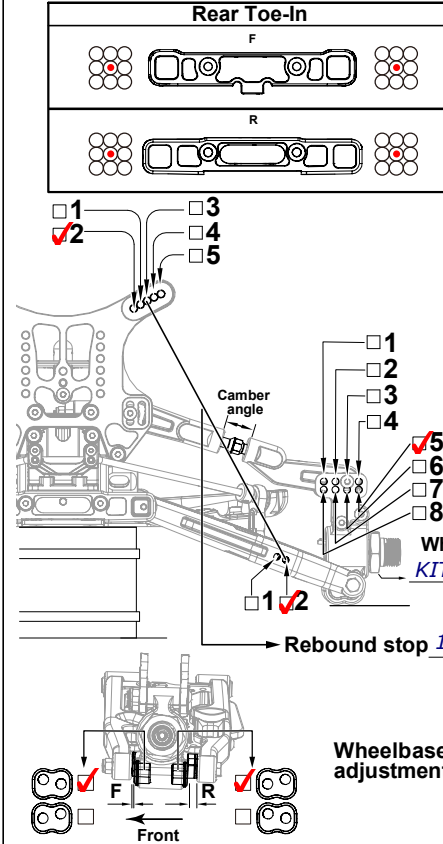

Body: Bitty Vision
Wing: T-Pro

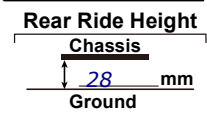
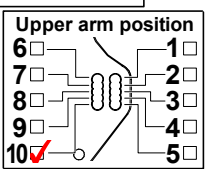
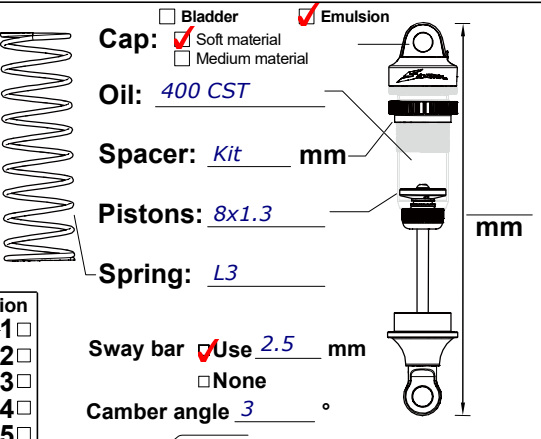
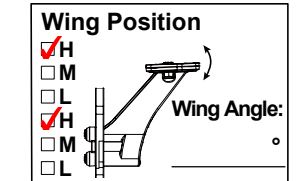

- Wheel Hub Note: KIT
- Wheelbase F 1 mm adjustment R 1 mm
- A Brass(15g) x _____
B Brass(15g) x 1
C Brass(15g) x 1

Option Parts List

Front Upper Arm
 Hard Soft
Carbon Cover _____ mm

Front Lower Arm
 Hard Medium Soft
Carbon Cover _____ mm

Rear Lower Arm
 Hard Medium Soft
Carbon Cover _____ mm