



SET-UP SHEET

Race time / Lap: _____
Best lap: _____

S35-GTE

1/8 Scale 4WD Brushless Power On-Road GT Car

Name: _____
Date: _____
Track: _____

Diff. Oil
Front: # _____
Center: # _____
Rear: # _____

Tire
Front Type: _____ Rear Type: _____
Foam: _____ Foam: _____

Track Conditions
Size: Open Med. Tight
Traction: High Med. Low
Surface: Smooth Med. Bumpy

Electric System
ESC Type: _____
Motor Type: _____
Motor Gear/Spur Gear: _____
Battery Type
A: Standard Pack _____
B: Shorty Pack _____

Front Suspension

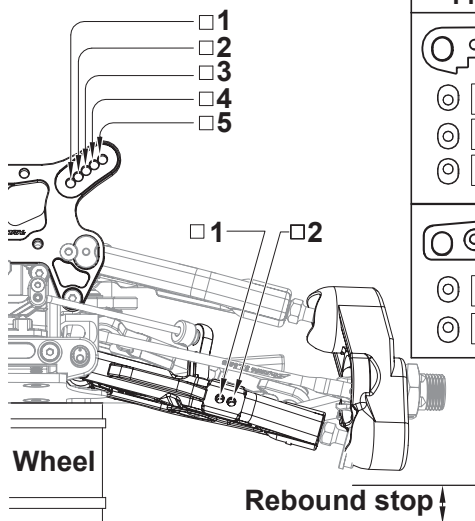

Front Toe-In

-1
 0
 +1

0
 +1

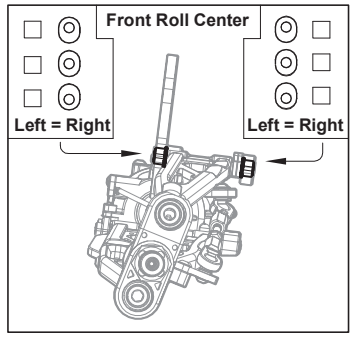

Track width _____ mm
Camber angle Upper _____ mm
Lower _____ mm
Toe angle _____
Rebound stop _____ mm
Sway bar Use _____ mm
 None

Front Shocks
Oil: _____
Pistons: _____
Spring: _____
Spacer: _____ mm

Camber Angle
L: _____ °
R: _____ °

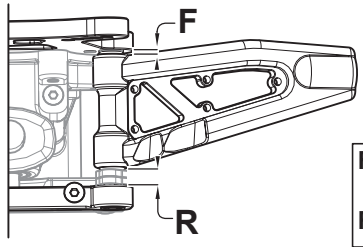
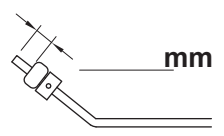

F: _____ mm
R: _____ mm

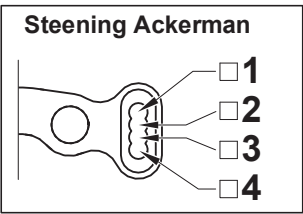

Notes: _____

Body: _____
Wing: _____

Rear Suspension

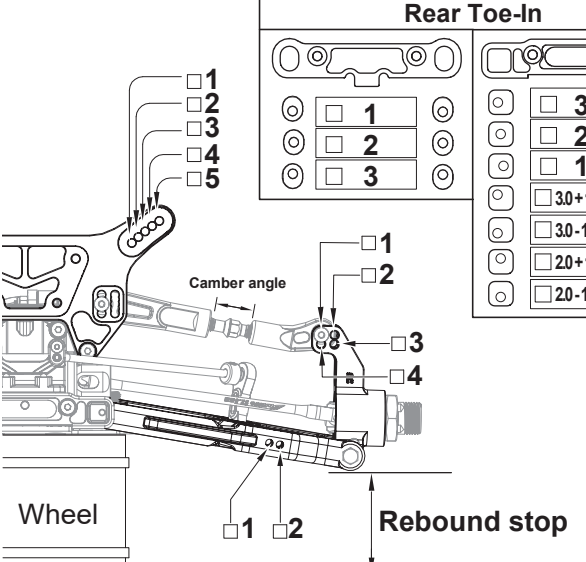

Rear Toe-In

1
 2
 3

3.0
 2.0
 1.0
 3.0+1K-Up
 3.0-1K-Up
 2.0+1K-Up
 2.0-1K-Up

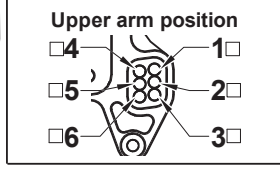

Camber angle _____ mm
Rebound stop _____ mm

Rear Shocks
Oil: _____
Pistons: _____
Spring: _____
Spacer: _____ mm

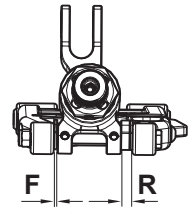

Wheelbase F _____ mm
adjustment R _____ mm

Sway bar Use _____ mm
 None

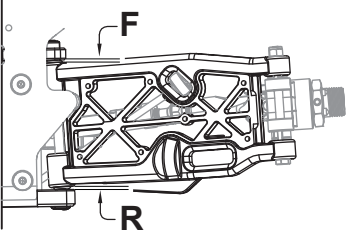

Notes: _____

