

SETUP SHEET



DRIVER, TRACK AND RESULTS

DRIVER Billy Easton COUNTRY **WEATHER** AIR TEMP TRACK TEMP DRY INTERMEDIATE WET
RACE Summer Scorchers DATE July 18, 2016 QUALY POS. 1st STARTING POS. 1st FINAL POS. 2nd FASTEST LAP
TRACK TYPE TIGHT MEDIUM OPEN GRIP LOW MEDIUM HIGH
SURFACE CONDITION SMOOTH ROUGH
TYPE HARD PACKED CLAY MULTI/SURFACE GRASS BLUE GROOVE DIRT ASTRO-TURF

FRONT SHOCK ABSORBERS		REAR	
600 cst	OIL	625 cst	
Green V2	SPRINGS	Green V2	
5 mm	REBOUND	5 mm	
N° HOLES 5	Ø 1.4 mm	PISTONS N° HOLES 5	Ø 1.4 mm
<input type="checkbox"/> BLADDER	SEAL TYPE	<input type="checkbox"/> BLADDER	
<input checked="" type="checkbox"/> EMULSION		<input checked="" type="checkbox"/> EMULSION	

FRONT ANTI-ROLL BARS		REAR	
<input type="checkbox"/>	<input type="checkbox"/>	<input type="checkbox"/>	<input checked="" type="checkbox"/>
1.8	2.0	2.3	2.5
<input type="checkbox"/>	<input checked="" type="checkbox"/>	<input type="checkbox"/>	<input type="checkbox"/>
2.5	2.7	1.8	2.0
<input type="checkbox"/>	<input type="checkbox"/>	<input type="checkbox"/>	<input type="checkbox"/>
2.3	2.5	2.7	<input checked="" type="checkbox"/>

DIFFERENTIAL OIL		
FRONT DIFF	CENTER DIFF	REAR DIFF
7000 cst	10000 cst	5000 cst

GEARING	
CLUTCH BELL	13 Teeth
SPUR GEAR	48 Teeth
GEAR MESH PLATE <input type="checkbox"/> A <input type="checkbox"/> B <input type="checkbox"/> C <input type="checkbox"/> D <input type="checkbox"/> E <input type="checkbox"/> F	

CLUTCH	
CLUTCH BELL	FLYWHEEL
<input checked="" type="checkbox"/> STANDARD <input type="checkbox"/> VENTED	<input type="checkbox"/> STEEL <input checked="" type="checkbox"/> ALU
CLUTCH SHOES	CLUTCH SPRINGS
SHOE TYPE <u>alu</u> x <u>4</u>	with SPRINGS TYPE <u>0.95</u> mm
SHOE TYPE <input type="text"/> x <input type="text"/>	with SPRINGS TYPE <input type="text"/> mm

ENGINE, PIPE AND FUEL	
ENGINE BRAND	Picco
TYPE	5TB
HEADSHIMS	mm
GLOWPLUG	CARB Ø mm
EXHAUST PIPE	Picco
MANIFOLD	Picco
FUEL BRAND	Sidewinder
NITRO	30 %

FLEX CONFIGURATION	
ENGINE MOUNT	<input type="checkbox"/> STANDARD <input checked="" type="checkbox"/> MONOBLOCK

AERODYNAMIC CONFIGURATION	
BODY	<input checked="" type="checkbox"/> STANDARD <input type="checkbox"/> HIGH DOWNFORCE <input type="checkbox"/> OTHER
WING	
TYPE	SRX8
WING PLATES	<input type="checkbox"/> 2° <input checked="" type="checkbox"/> 4° <input type="checkbox"/> 6°
GURNEY STRIP	<input type="checkbox"/> YES <input type="checkbox"/> NO
CENTER FOIL	<input type="checkbox"/> YES <input type="checkbox"/> NO

FRONT TIRES		REAR	
Proline	MAKE	Proline	
X2 Fugitive	TYPE	X2 Fugitive	
Proline	INSERTS	Proline	
Serpent	WHEELS	Serpent	

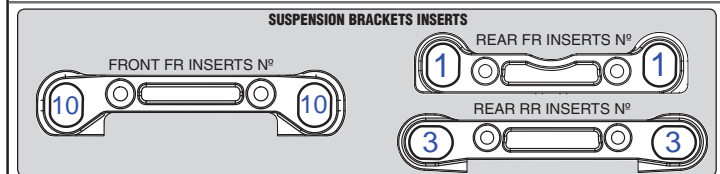
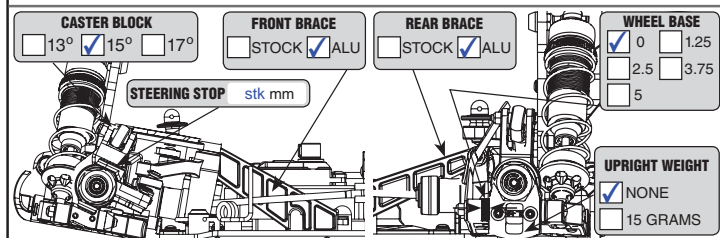
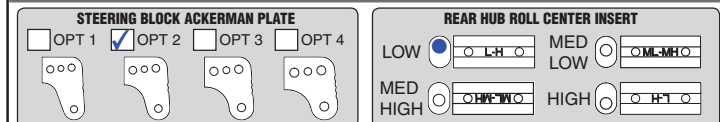
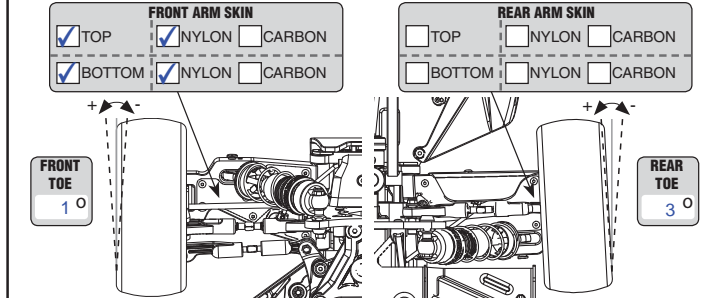
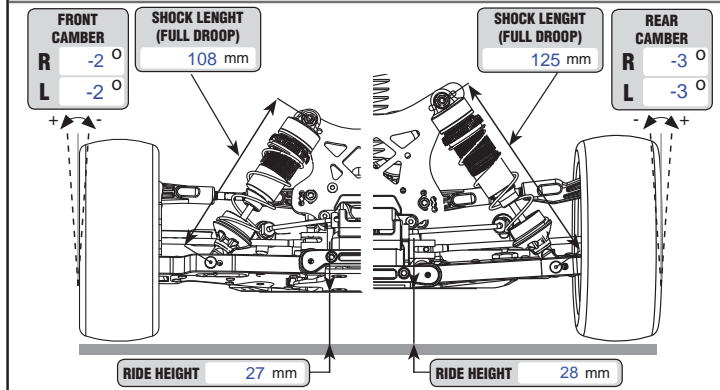
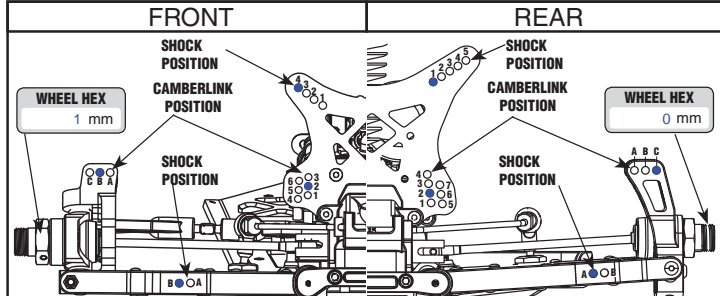

REMARKS