

SRX4

gen3

INSTRUCTION
MANUAL



SERPENT
INNOVATIONS

INTRODUCTION

Thank you very much for selecting this Serpent rc car and thus become a member of the ever growing worldwide Serpent racing family. Serpent started in 1980 and has been growing its product-line and fan-base ever since.

The Serpent SRX4 Gen3 is a state of the art 1/10 scale 4wd buggy, which will give you the true Serpent racing experience. The assembly manual will guide you through all the steps to complete the car, so you can hit the track with a good base set-up. The Serpent design department succeeded to create a superbly performing car combined with ease of assembly and maintenance. The high quality standards of all parts and hardware will make racing your Serpent car a very rewarding activity!

Through our team, website and social media we will keep you up-to-date on all developments of the Serpent cars. We hope to meet you on the track and through our various media! Enjoy the drive!

Team Serpent
Multiple World Champions

INSTRUCTIONS

Serpent's long tradition of excellence extends to the instruction manuals, and this instruction manual is no exception. The easy-to-follow layout is richly illustrated with 3D-rendered full-color images to make your building experience quick and easy. Following the instructions will result in a well-built, high-performance race-car that will soon be able to unleash its full potential at the racetrack. The kit includes bags, with bag numbers, which refer to the same step in the manual. Open only the indicated bag(s) per step and finish that part of the assembly. Remaining parts will be needed later on in the assembly process.

PLASTIC PARTS

The Serpent moulded parts are very durable and hard. When assembling longer screws in new composite parts, make sure to use new hex bits in your (power) tools. Pre-threading also helps to avoid screw damage.

SETUP

In certain assembly steps you need to make basic adjustments, which will give you a good initial setup for your Serpent SRX4 Gen3. Fine-tuning the initial setup is an essential part of building a high-performance racecar like your Serpent SRX4 Gen3.

EXPLODED VIEWS AND PARTS LIST

The exploded views and parts lists for the Serpent SRX4 Gen3 are presented in the Reference Guide section in the back of this manual. The exploded views show all the parts of a particular assembly step along with the Serpent part number and hotlink to the Serpent website. Part numbers in orange indicate that this part is an optional. Optionals part names and numbers are showed below.

CUSTOMER SERVICE

Serpent has made a strong effort to make this manual as complete and clear as possible. Additional info may be published in our website: www.serpent.com or you may ask your dealer or the Serpent distributor for advice, or email Serpent direct: info@serpent.com. The Serpent Facebook, Twitter and Youtube pages give additional means of support and communications.

SAFETY

Read and take note of the 'Read this First section' before proceeding to assemble the car-kit. This car-kit is intended for persons aged 16 or older.

READ THIS FIRST!

- This is a highly technical hobby product, intended to be used in a safe racing environment. This car is capable of speeds in excess of 80 km/h or 50mph. Please follow these guidelines when building and operating this model.
- Parental guidance is required when the builder/user of this car is under 16.
- Follow the building instructions. If in doubt, contact your dealer or importer.
- Be sure to use the proper tools when assembling the car. Always exercise caution when using electric tools, knives and other sharp objects.
- Be careful when using liquids like lubrication oil, fuel or glue. Do not swallow.
- Follow the manufacturer's instruction in case you experience irritation after using the product.
- Be careful when operating the car. Stay away from any rotating parts such as wheels, gears and transmission. Stay away from motor, engine and exhaust pipe system or speedo during and immediately after use, as these parts may be very hot. We advise to use protective hand gloves.
- Only operate this car in a safe environment, like a special racing track or a closed parking lot. Avoid using this car on public roads, crowded places or near infants.
- Before operating this car, always check the mechanical status of the car. Also check that the transmitter and receiver frequencies correspond and are not used by any other racer at the same time. Check that the batteries of the transmitter and receiver- are fully charged.
- After use, always check all the mechanics of the car. We advise to clean the car immediately after use, and inspect the parts for wear or fractures. Replace when necessary. Do not use water, methanol, thinner or other solvents to clean the car.
- Empty the fuel tank (depending on model) if needed and disconnect the receiver battery.
- Store the car in a dry and heated place to avoid corrosion of metal parts.
- Avoid using this car in wet conditions as the water will cause corrosion on the metal parts and bearings and these parts will cease to function properly. If driven in the wet, ensure that all the electric equipment is waterproofed and after use, that all moving parts are dried immediately.

CONTENTS

• REAR DIFF ASSEMBLY	4
• FRONT DIFF ASSEMBLY	6
• CENTER CHASSIS ASSEMBLY	8
• TRANSMISSION ASSEMBLY	11
• REAR ASSEMBLY	19
• FRONT ASSEMBLY	25
• SHOCKS ASSEMBLY	31
• FINAL ASSEMBLY	34
• EXPLODED VIEWS	37
• TEAM SERPENT NETWORK	48

SRX4
gen3

LINES DESCRIPTION

Each step contains a variety of numbers, lines, and symbols. The numbers represent the order in which the parts should be assembled. The lines are described below.



Step number; the order in which you should assemble the indicated parts



Length after assembly



Assembly path of one item into another



Group of items (within lines) should be assembled first



Direction the item should be moved



Glue one item to another



Connect one item to another



Gap between two items



Press/Insert one item into another

ICONS DESCRIPTION

Each step contains a variety of symbols described below.



Carefully, read and check extensively.



Apply a small amount of cyano glue. Use wear protection for eyes and hands.



Detail view to explain assembly or order of parts better.



Default set-up: This symbol indicates the default setup.



Grease: apply a small amount of grease to the parts shown.



Silicone grease: apply a small amount of grease to the parts shown.



Thread lock: apply a small amount on the parts shown. Before to apply the threadlock, make sure to degrease the parts very well, as otherwise the threadlock will not work.



Silicone oil: use the indicated silicone oil for the shocks and differentials.



Oil: apply a small amount of oil to the parts shown.



Left and right parts should be assembled in the same way.



Parts or items not included in the kit.



Optional part, not standard in the kit.

STEP 1

DIFF BAG RR

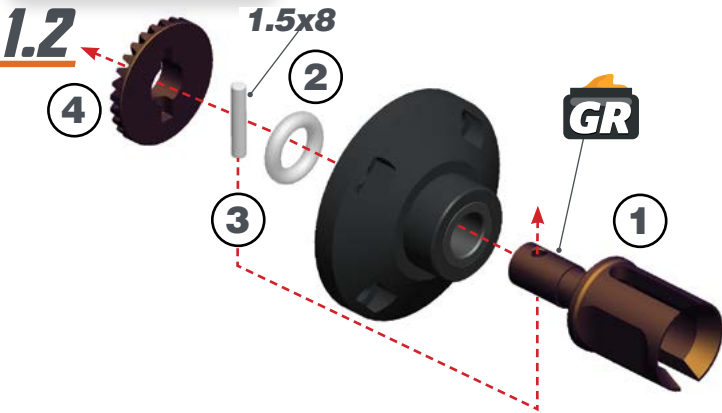
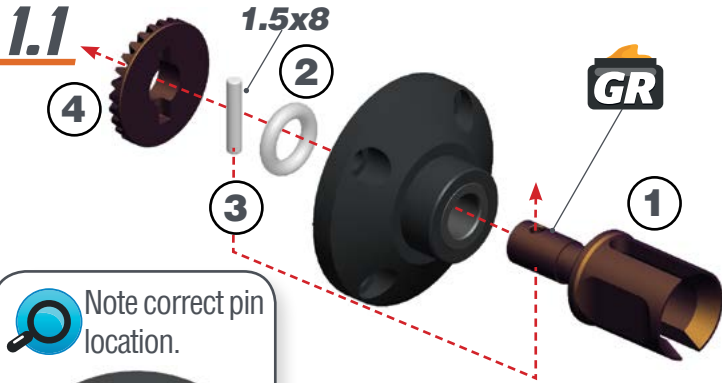

1.5x8

STEP 2

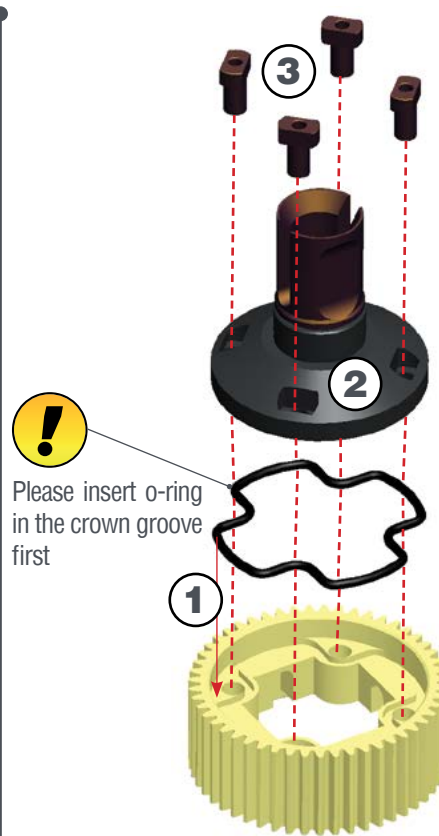

STEP 3

3.1 Add just enough oil to cover the large gear before assembling the small satellite gears and cross pins.

Use the silicone oil supplied in the kit. For the correct cst value please check the default setup-sheet.



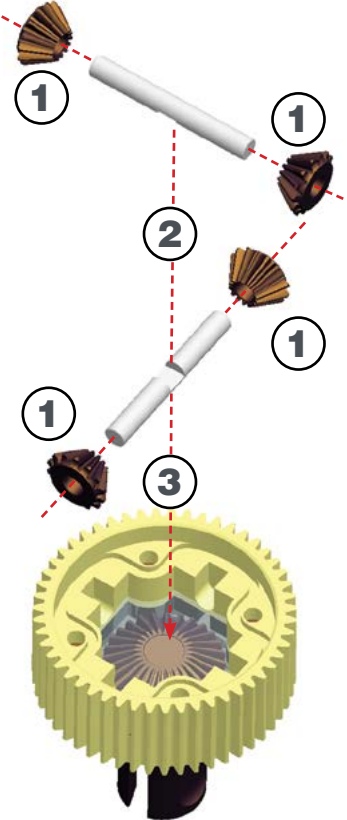

3.2

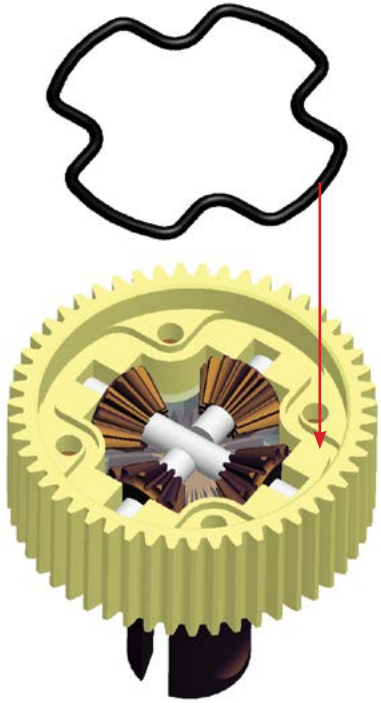

STEP 4

4.1  Fit the o-ring before finishing the filling of the differential.



4.2  Fill the differential to the brim with silicone oil, do NOT overfill. Use the silicone oil supplied in the kit. For the correct cst value please check the default setupsheet.

SO



 **AMOUNT OF OIL IN THE DIFFS**
Use a digital scale to measure the exact amount of oil in the diff.

Differential weight should be 17.3 - 17.5 grams.



STEP 5

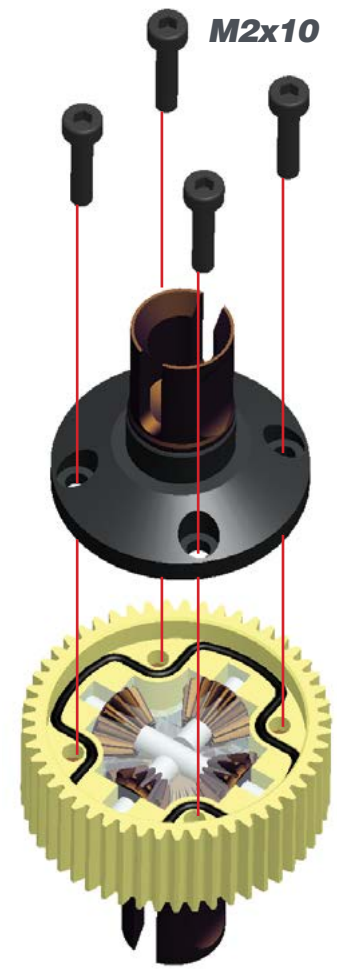

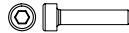
M2x10

STEP 6

DIFF BAG FR

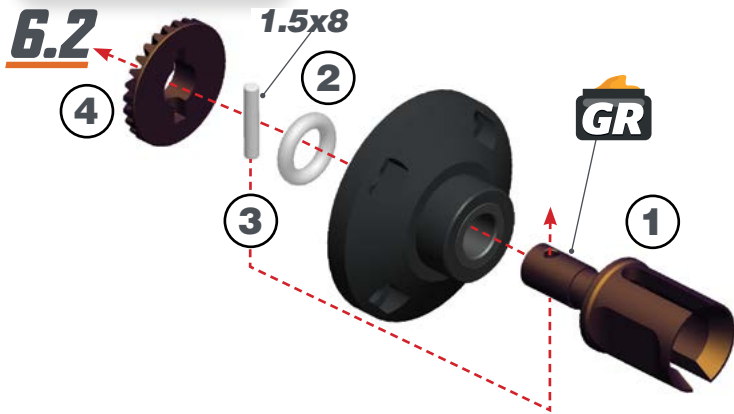
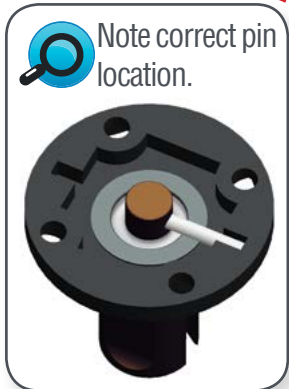
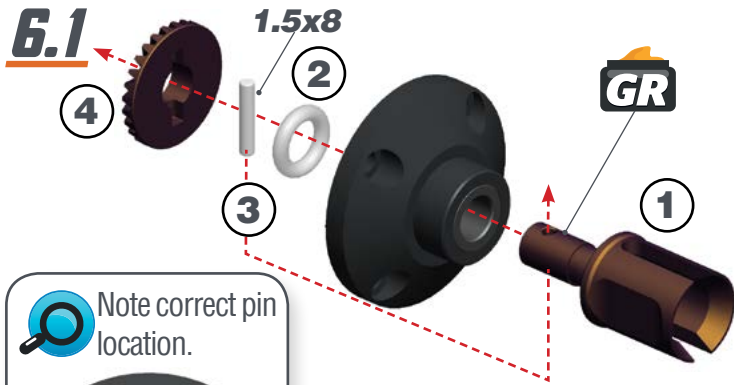

1.5x8

STEP 7



STEP 8

8.1 Add just enough oil to cover the large gear before assembling the small satellite gears and cross pins. Use the silicone oil supplied in the kit. For the correct cst value please check the default setup-sheet.



8.2

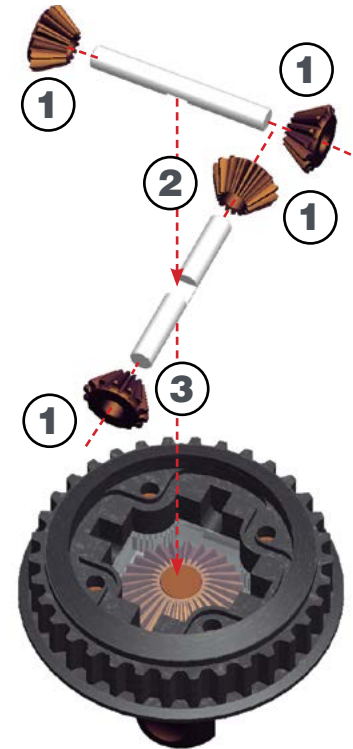

STEP 9

9.1  Fit the o-ring before finishing the filling of the differential.



9.2  Fill the differential to the brim with silicone oil, do NOT overfill. Use the silicone oil supplied in the kit. For the correct cst value please check the default setupsheet.



 **AMOUNT OF OIL IN THE DIFFS**

Use a digital scale to measure the exact amount of oil in the diff.

Differential weight should be 19.0 - 19.15 grams.



STEP 10

10.1  **M2x10**

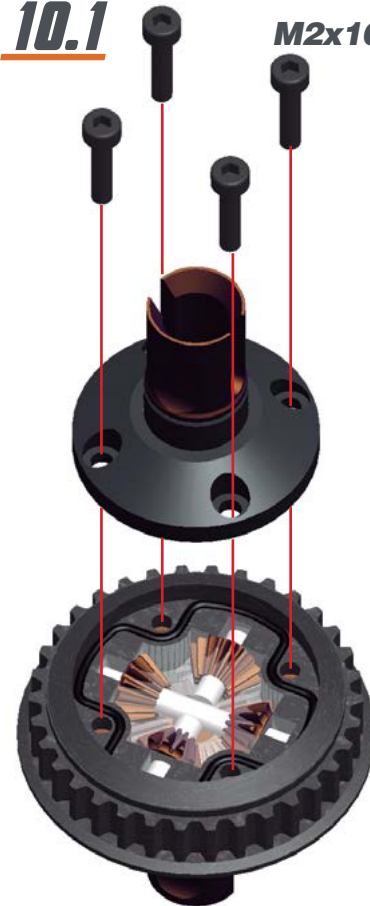

10.2   Apply some CA glue to fix the flange to the front diff.





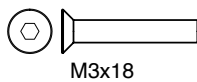
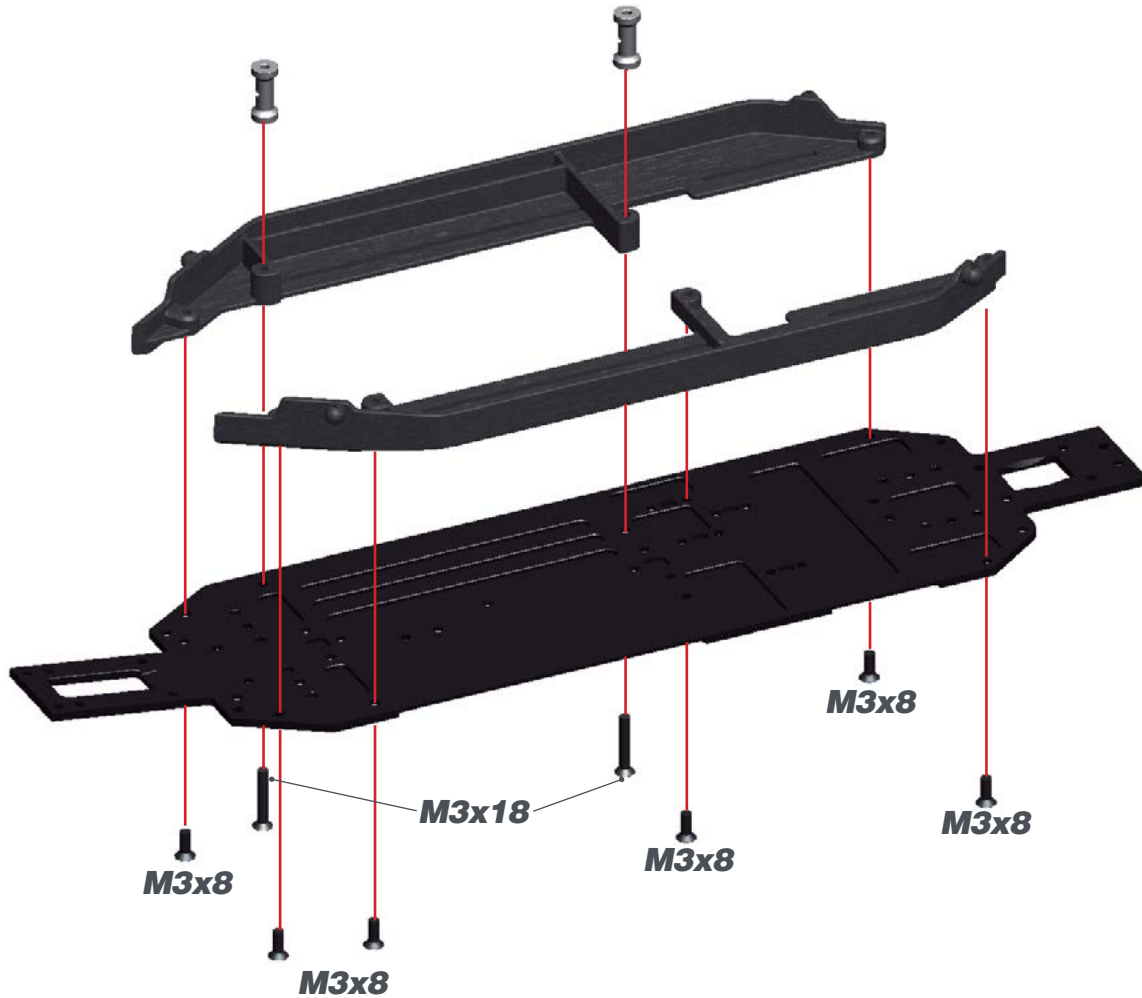

STEP 11

BAG 1

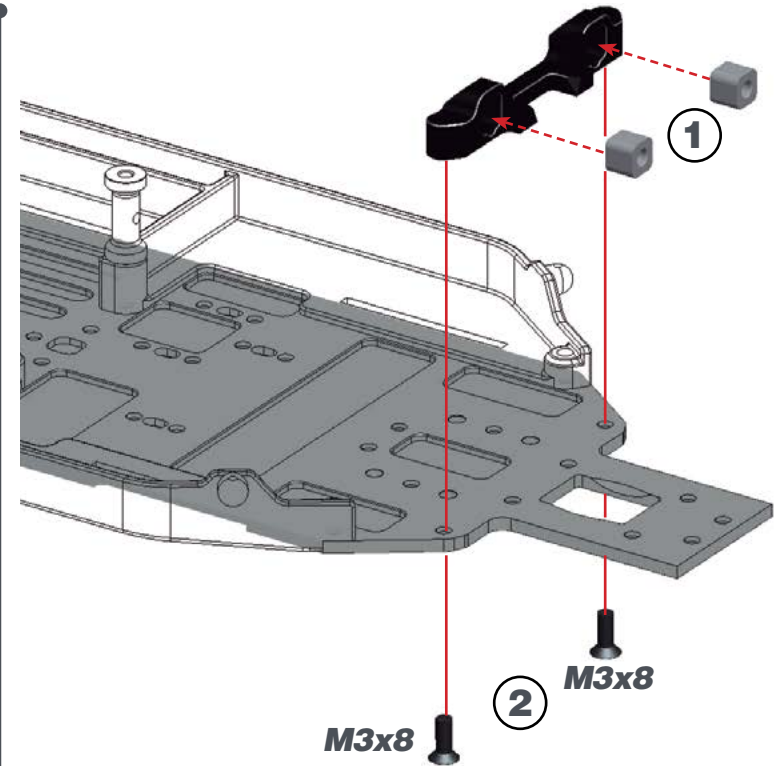

STEP 12



   **SUSPENSION INSERTS**

Please find qty. 2 Centered Inserts. These 0 inserts are the default setup and should be installed into this RR FR Toe block. Additional information can be found on page 21, for how you can use the inserts to adjust toe-in, anti-squat, and pivot width.



STEP 13

13.1

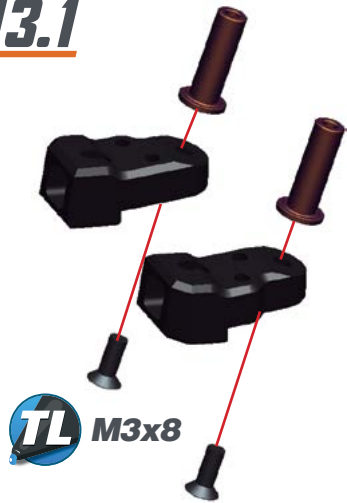

13.2

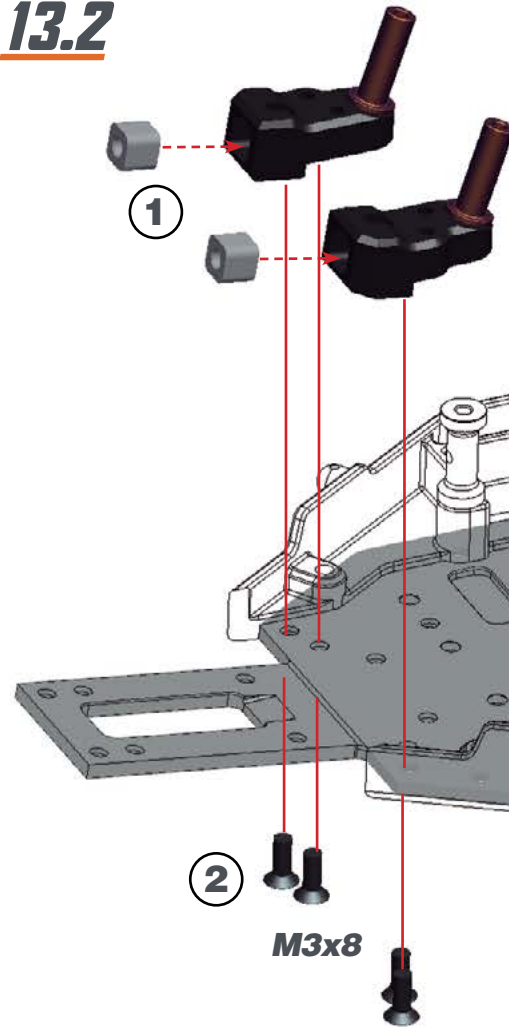

SUSPENSION INSERTS

Please find qty. 2 Centered Inserts. These 0 inserts are the default setup and should be installed into this FR RR Toe block. Additional information can be found on page 28, for how you can use the inserts to adjust toe-in, anti-squat, and pivot width.

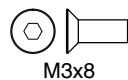

STEP 14

14.1  Please notice that there are two types of plastic guide mounts, low and high.

14.2

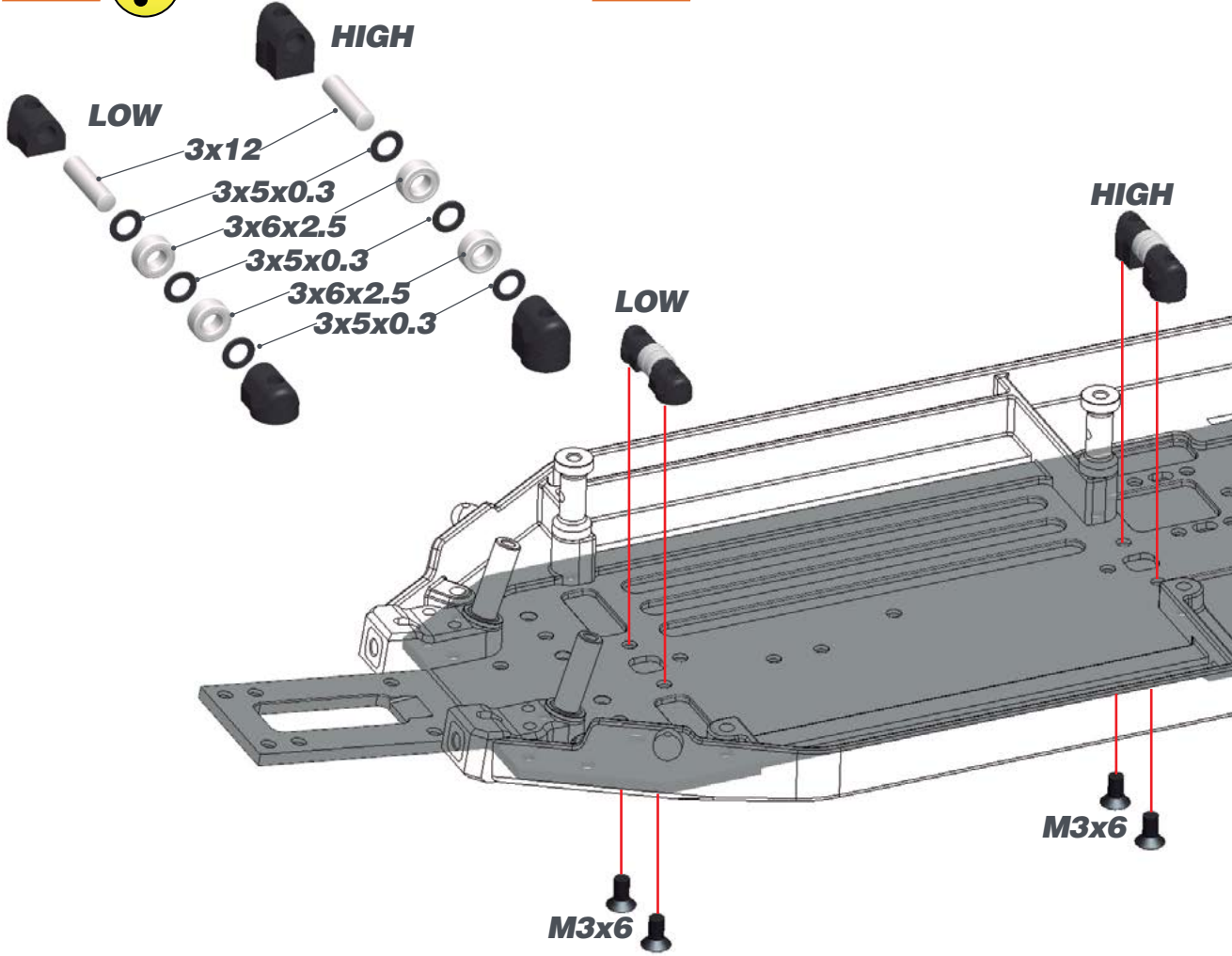

STEP 15

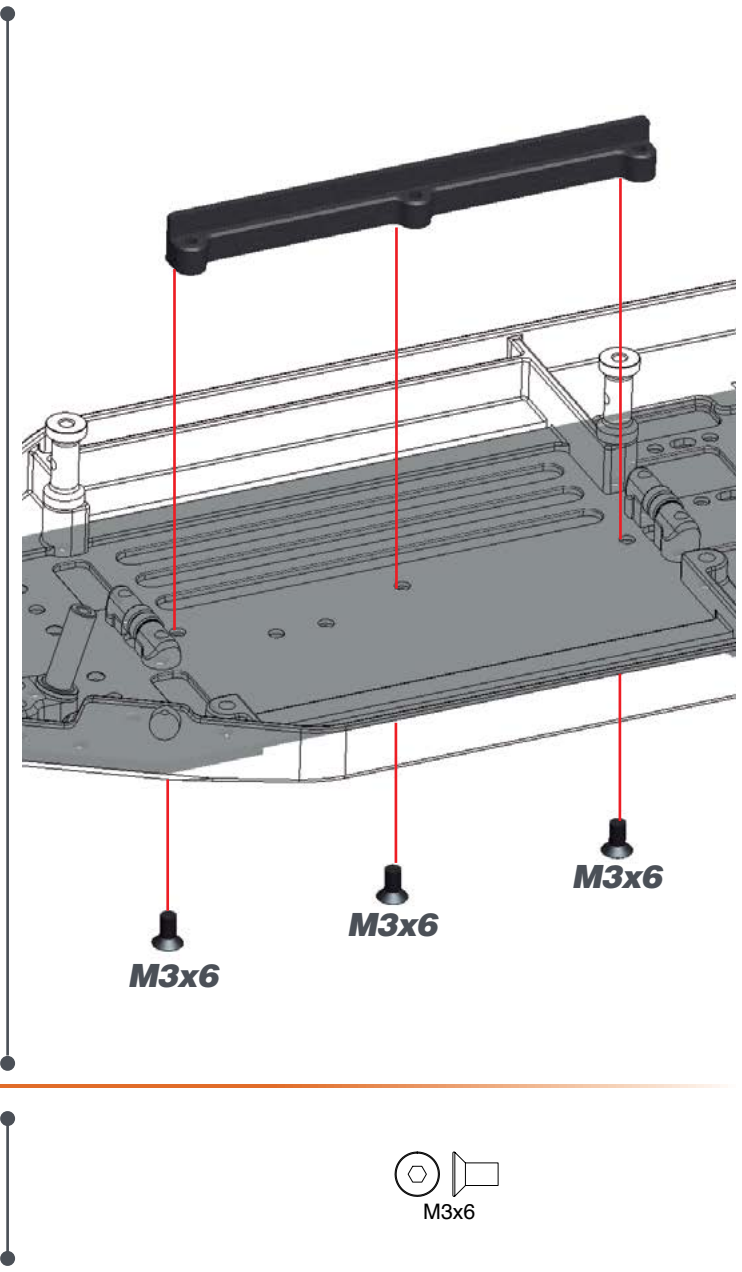

STEP 16

BAG 2

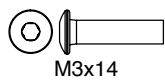
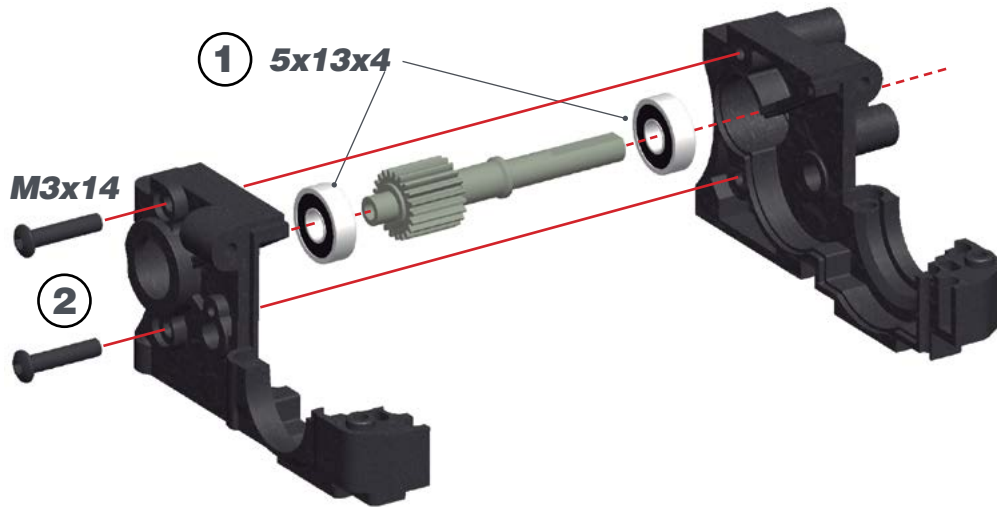

M3x14



5x13x4

STEP 17

17.1

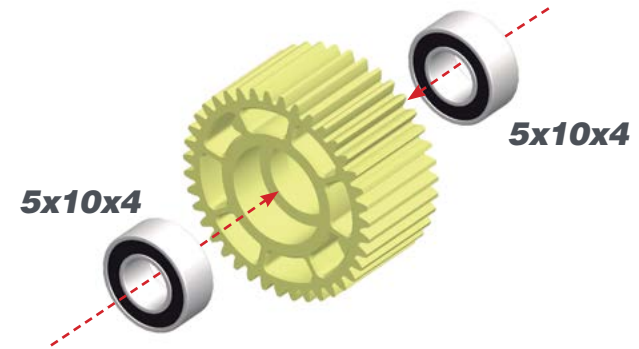

17.2

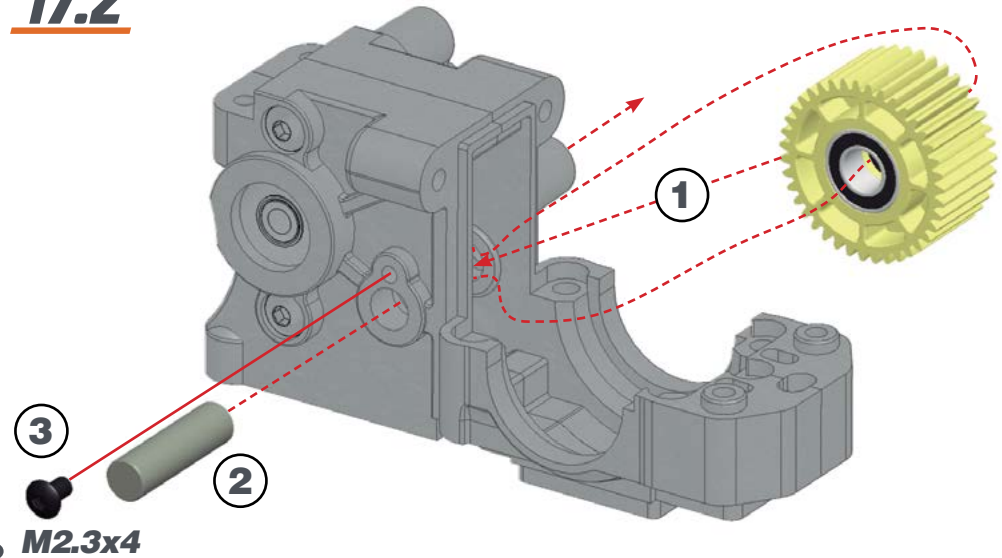

M2.3x4



5x10x4

STEP 18

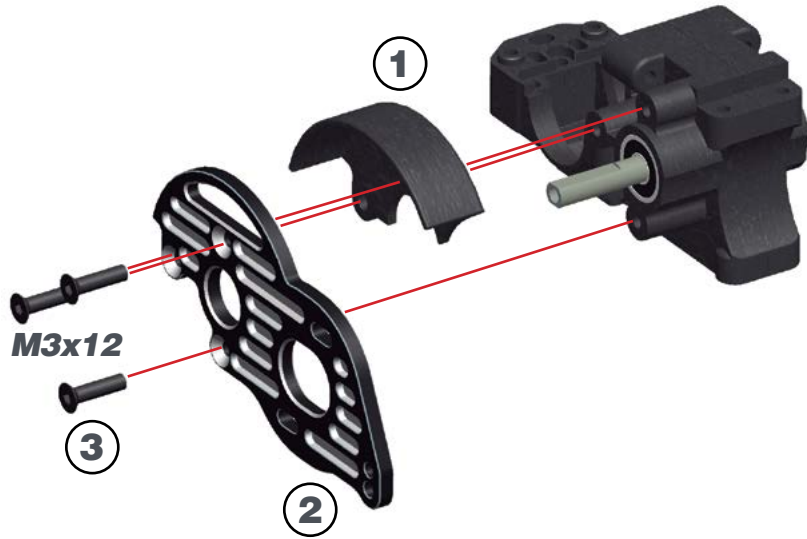

STEP 19

19.1

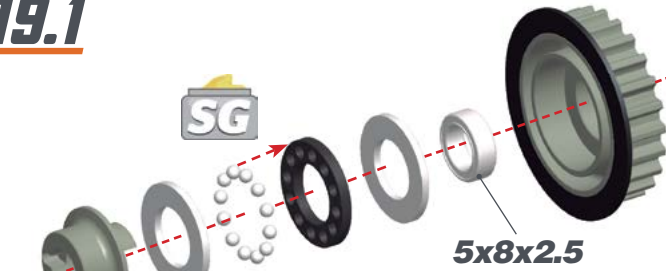

19.2

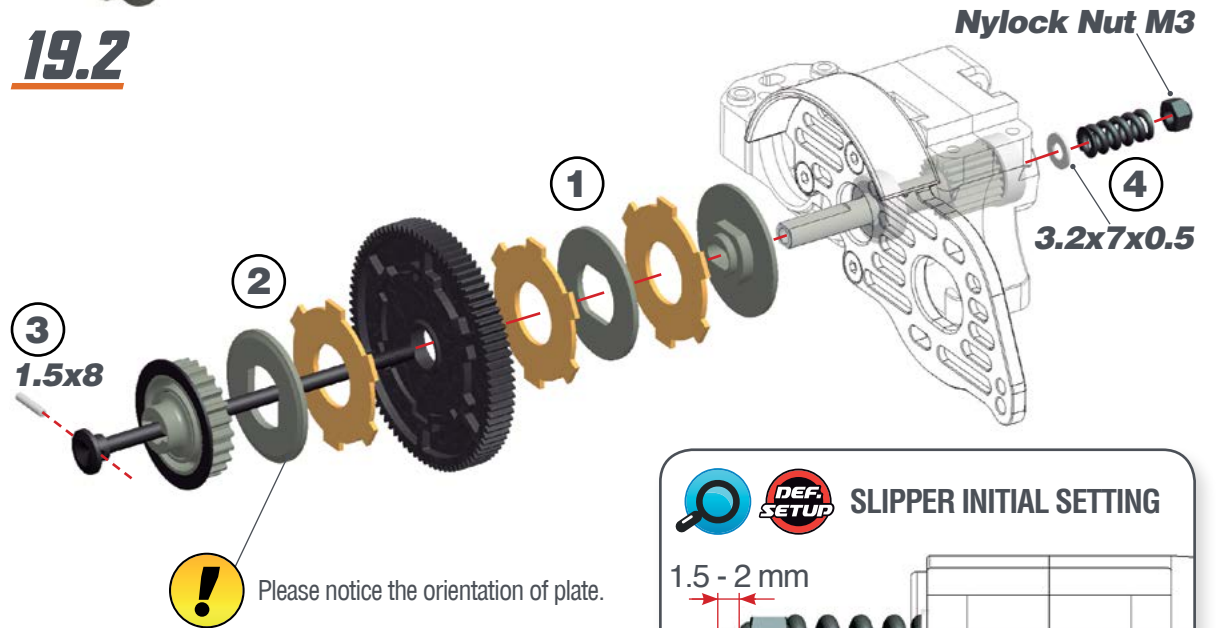

DEF. SETUP SLIPPER INITIAL SETTING

1.5 - 2 mm

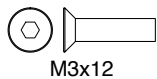

STEP 20

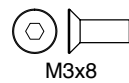
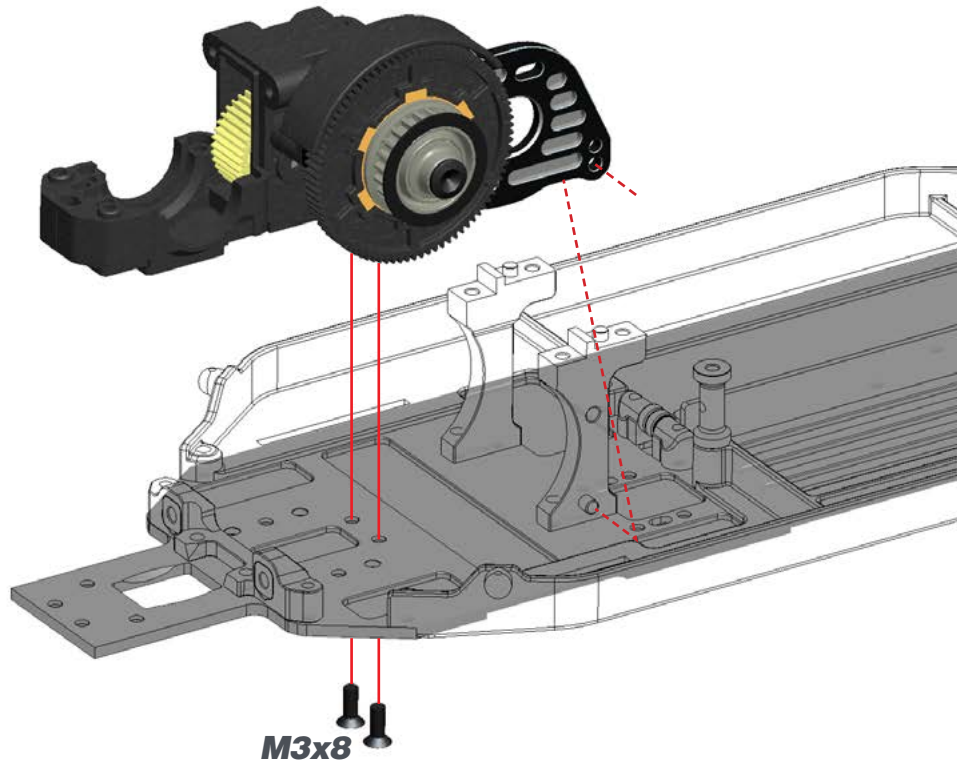

STEP 21

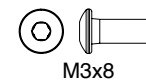
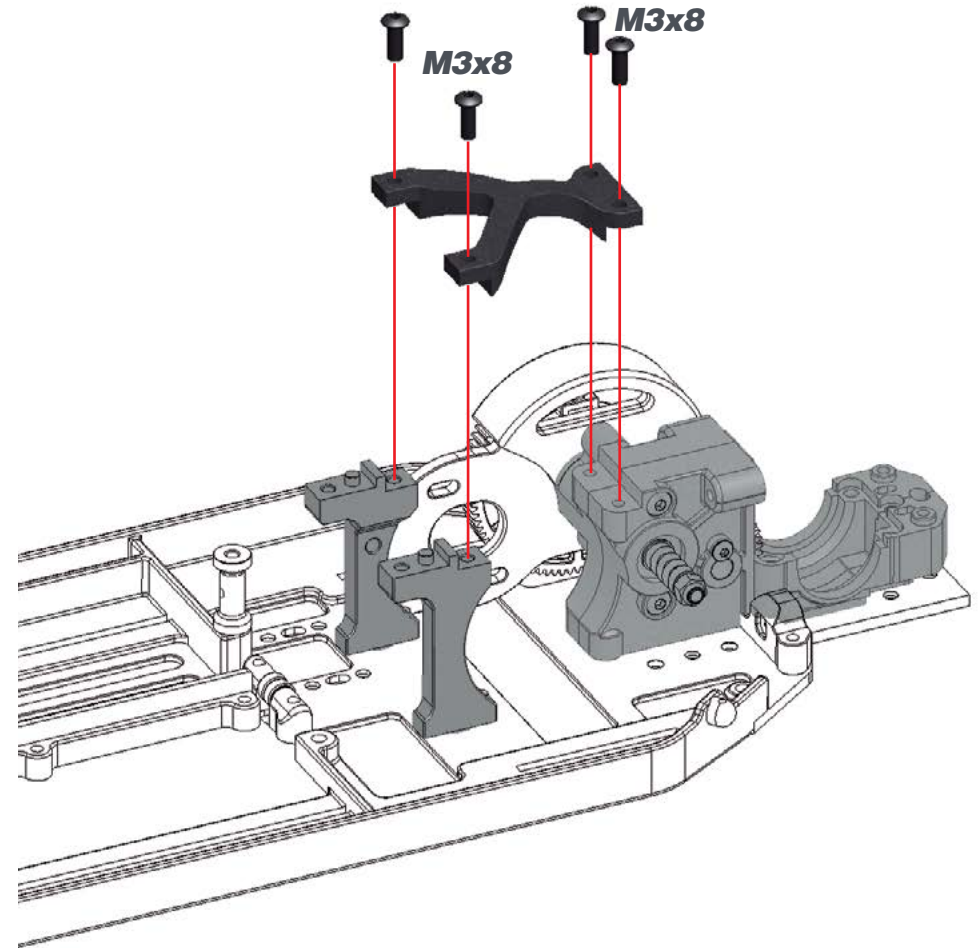

STEP 22 **BAG 3**

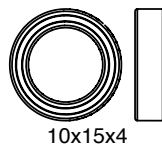
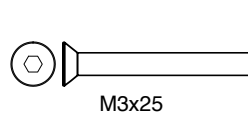
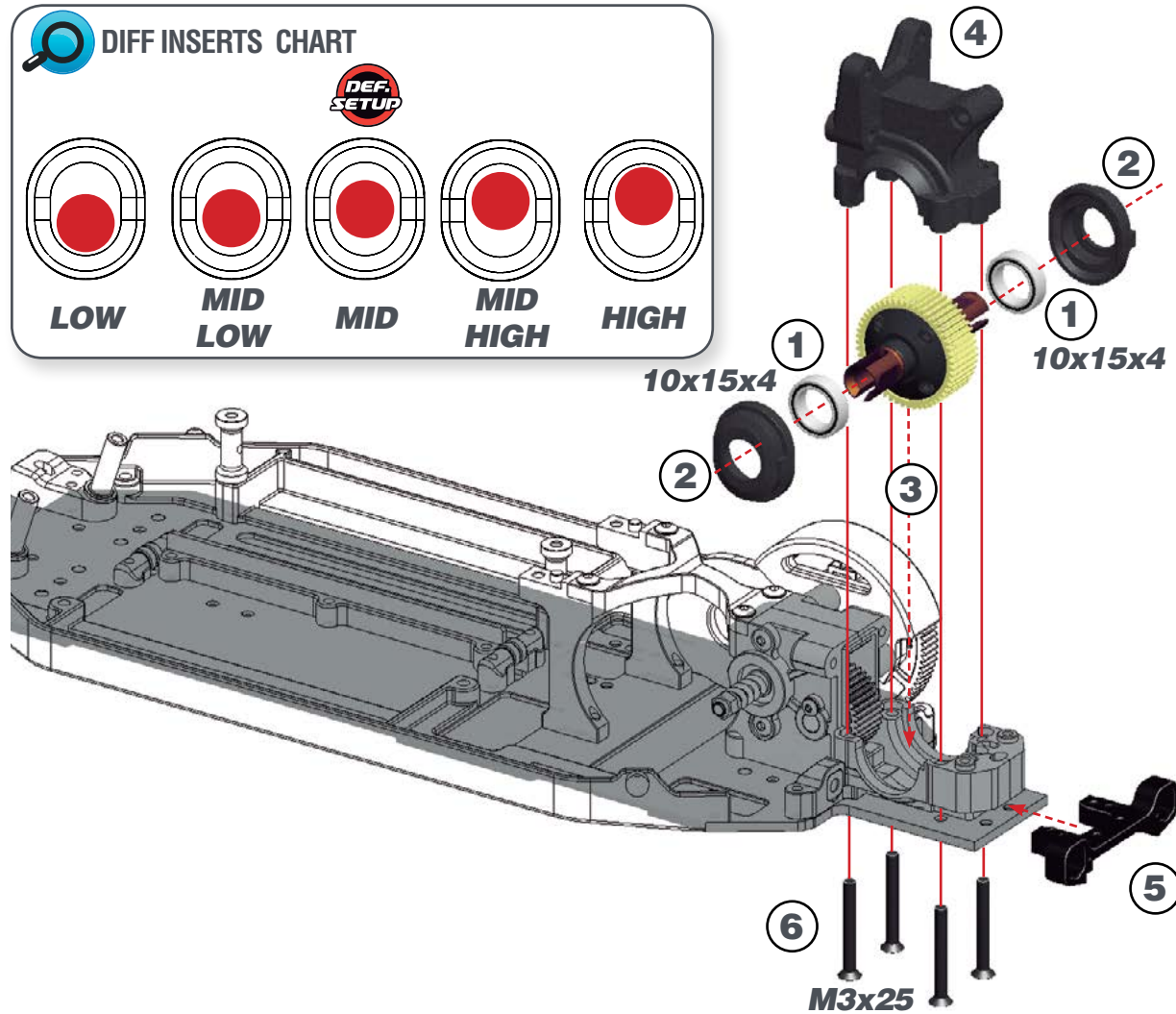
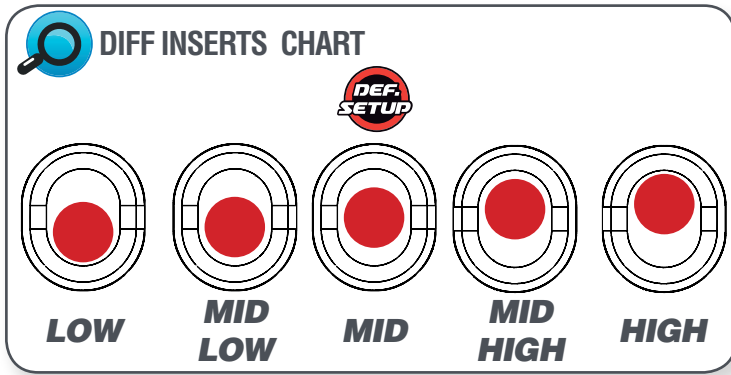

STEP 23

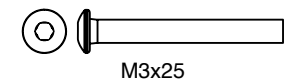
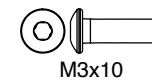
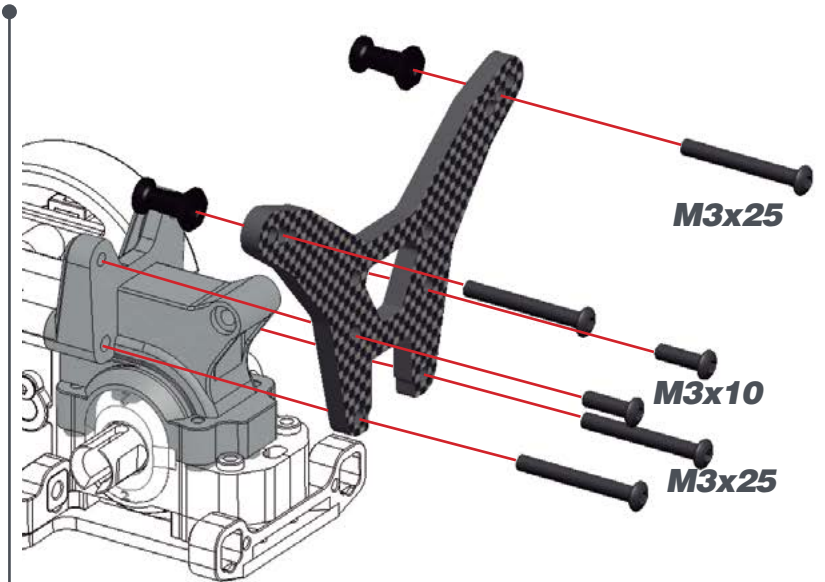

STEP 24

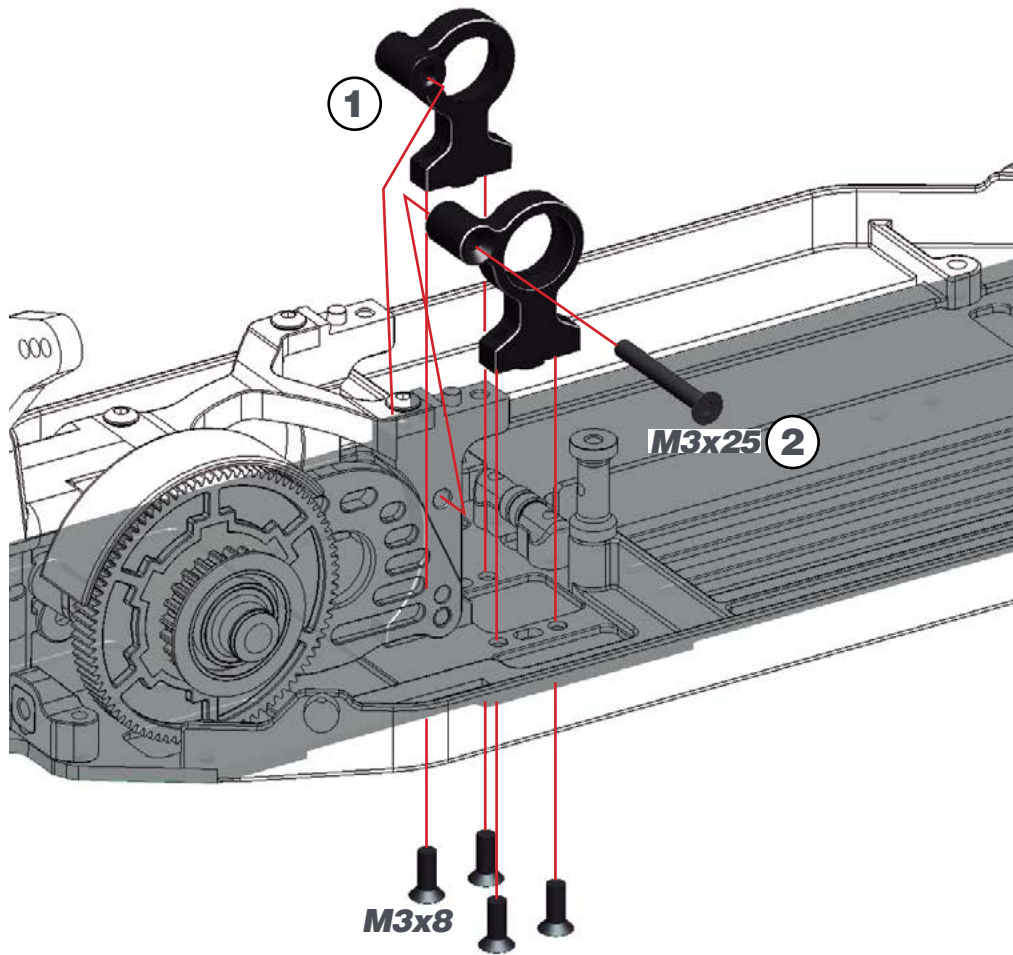

STEP 25

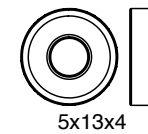
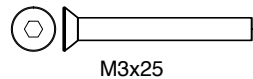
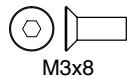
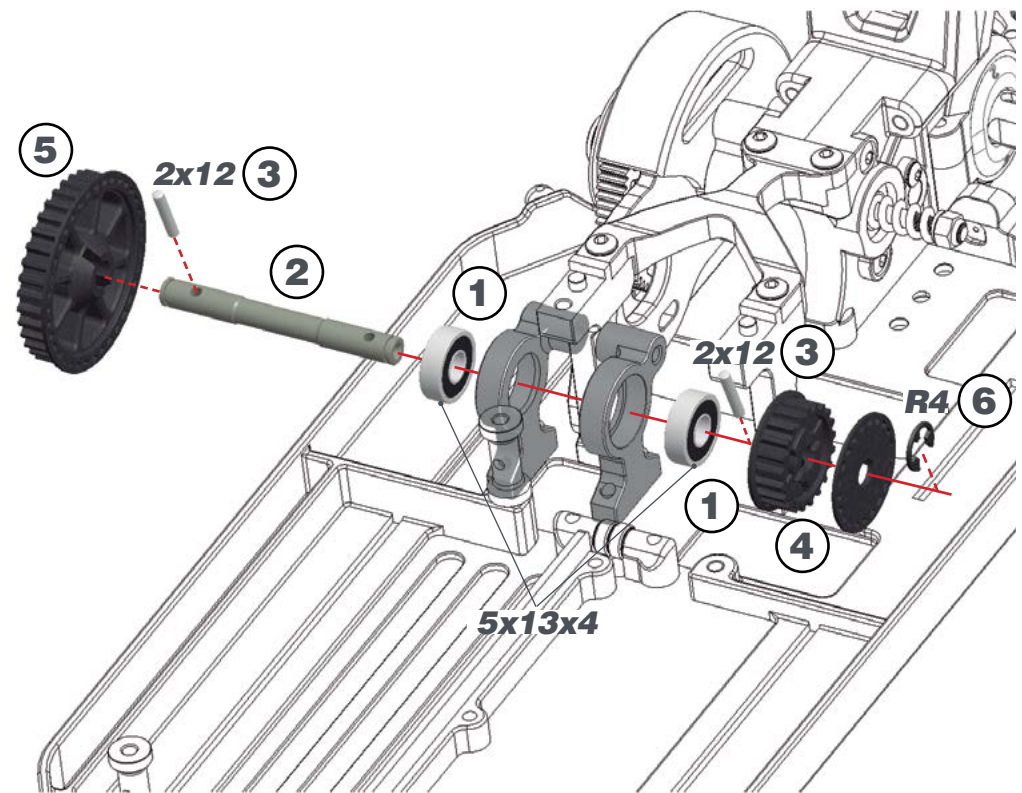

STEP 26



Assembly order:

- 1- Install the belt onto the LSD slipper pulley.
- 2- Roll the belt onto the 36t pulley.
- 3- Install the flange.
- 4- Assemble the circlip.

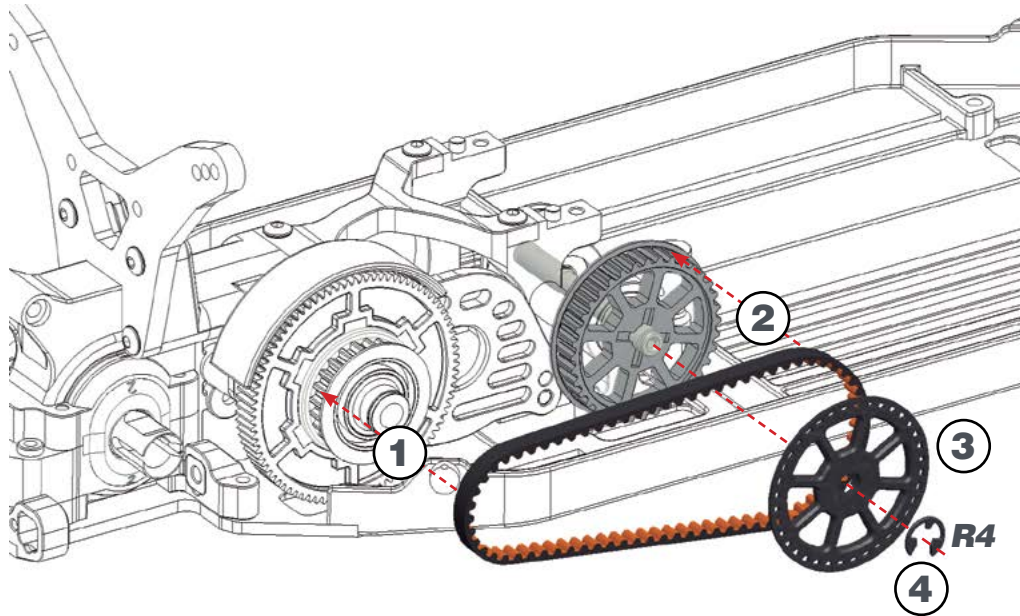

STEP 27

BAG 4

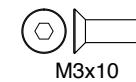
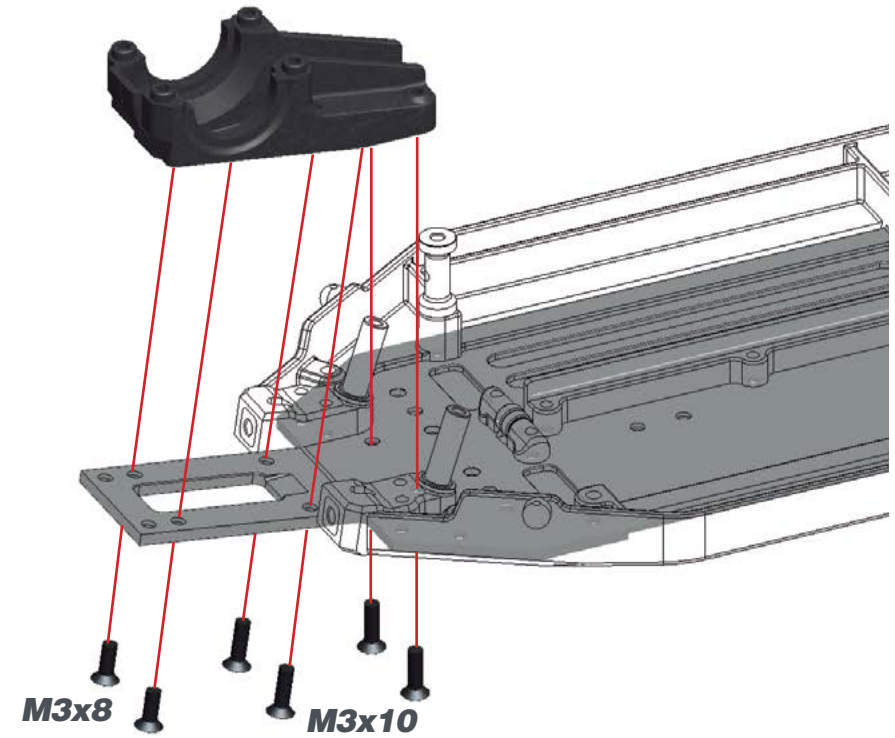

STEP 28

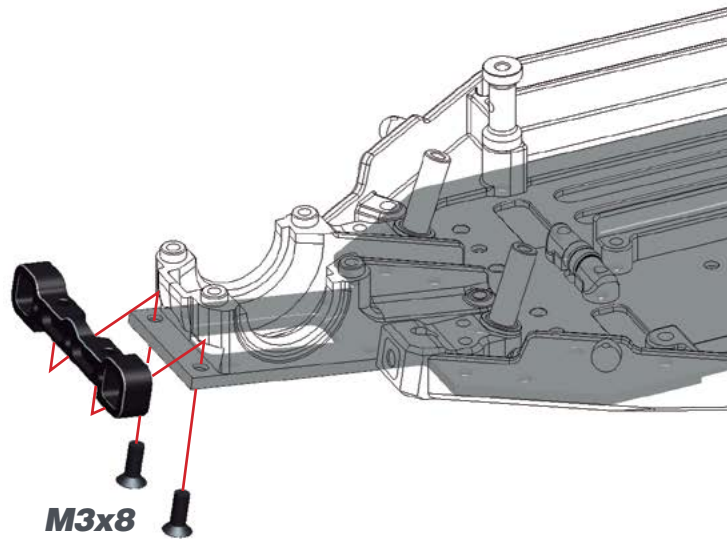

STEP 29



DIFF INSERTS CHART

LOW **MID LOW** **MID** **MID HIGH** **HIGH**

- !** Assembly order:
- 1- Install the front belt onto center 21t layshaft pulley.
 - 2- Install ballbearings and diff inserts onto the front diff.
 - 3- Loop onto the front differential.
 - 4- Slide Front differential with inserts into final bulkhead position.
 - 5- Install transmission case top and sway bar mount.

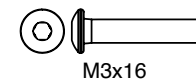
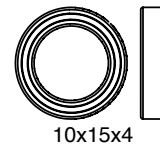
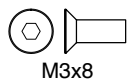
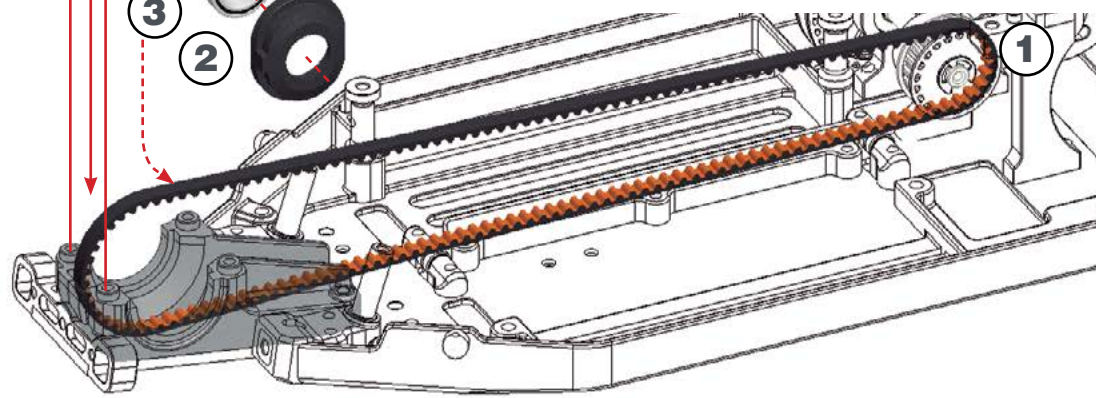

STEP 30

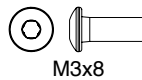
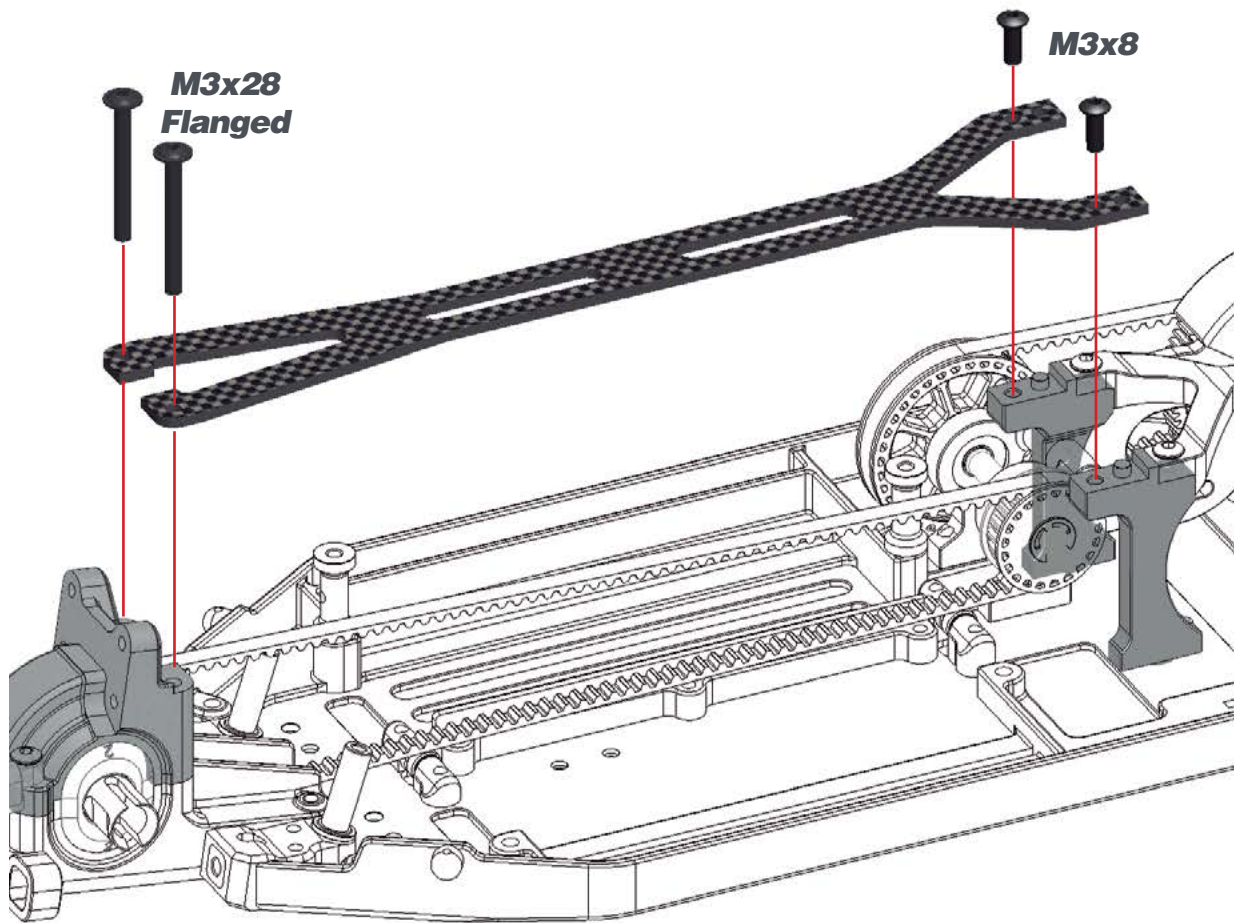

STEP 31

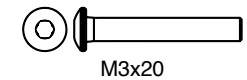
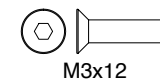
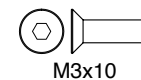
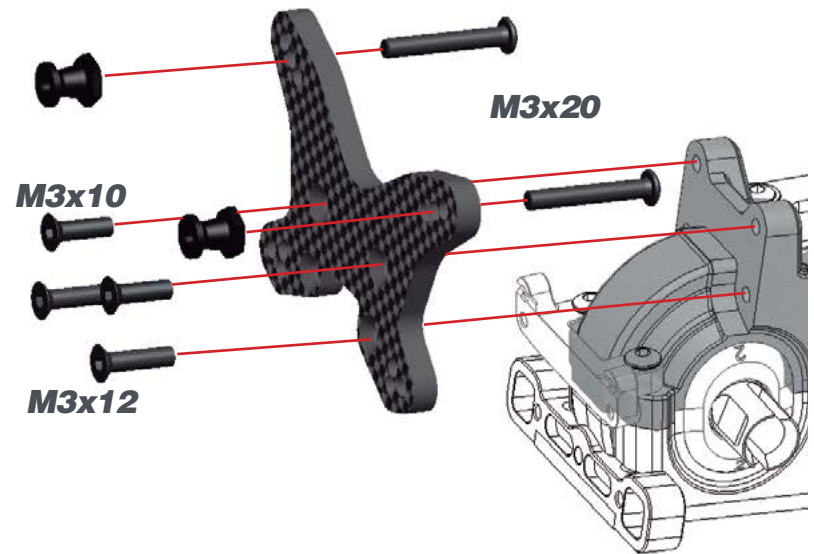

STEP 32

BAG 5

L=R

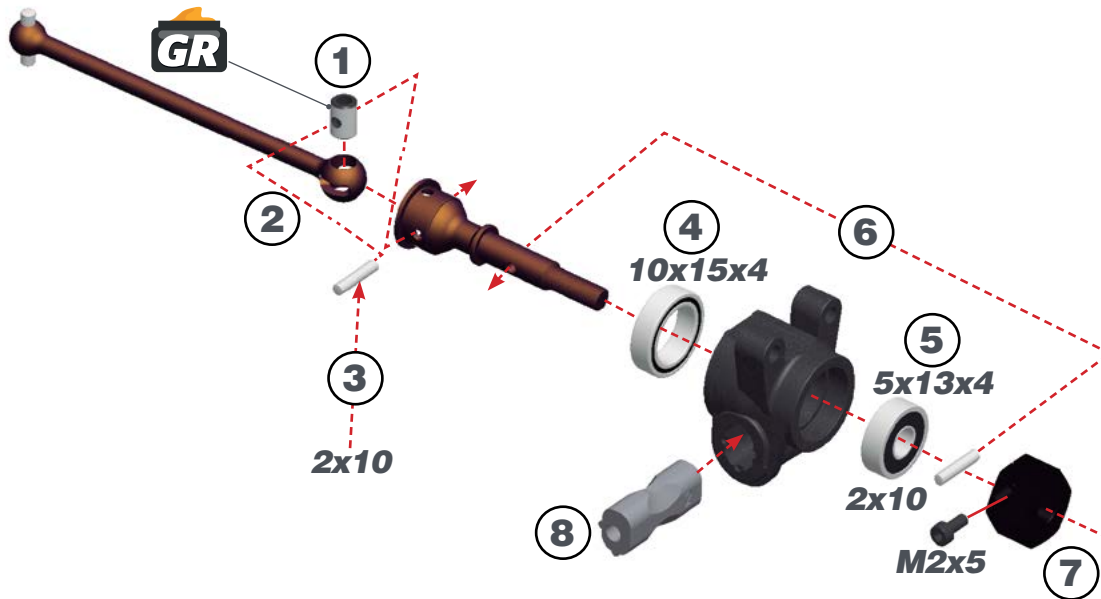

L=R REAR WHEEL-AXLE PIN FOR DRIVESHAFT POSITION

The axle has 3 pivoting choices. The shallowest hole will provide more chassis roll / less roll stiffness. The deepest hole will reduce chassis roll / increase roll stiffness. The center hole is recommended as its neutral.

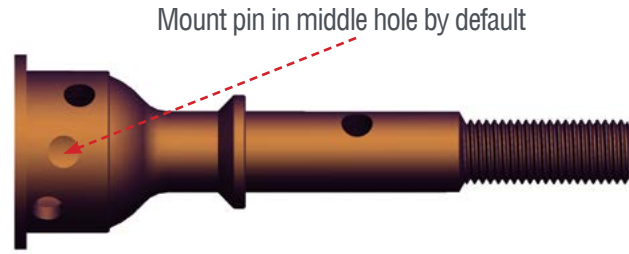

L=R REAR AXLE HEIGHT AND OFFSET INSERTS

Wide Offset		Narrow			
L	R	L	R		
		0mm	0mm		
		0.5mm	0.5mm		
		1mm	1mm		
		1.5mm	1.5mm		
		2mm	2mm		
		2.5mm	2.5mm		
		3mm	3mm		

DEF. SETUP

1) The axle height adjustment will give you the ability to adjust the roll center for various traction conditions. Typically in lower grip, you will run 0,+0.5,1 or 1.5mm / lower roll centers. In higher grip conditions you will want to use +2,2.5,3mm / higher roll centers.

2) The width offset will give you more versatility to adjust the track width, axle location and hex width. Especially useful when using Longer rear arm.

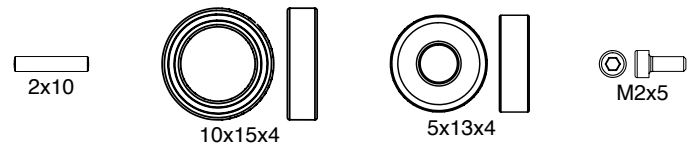

STEP 33

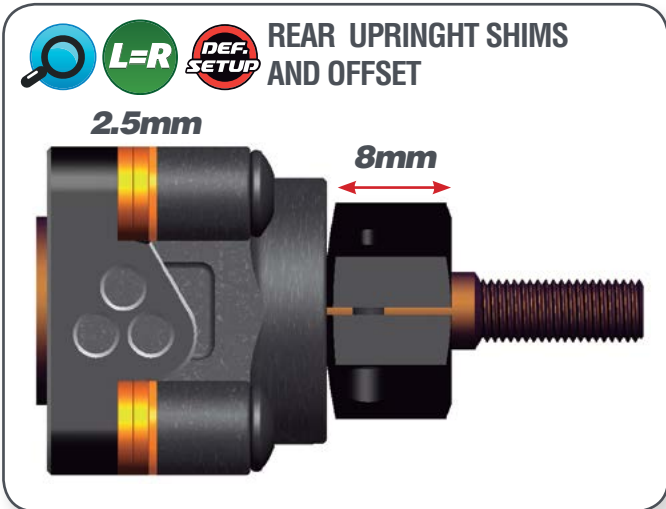
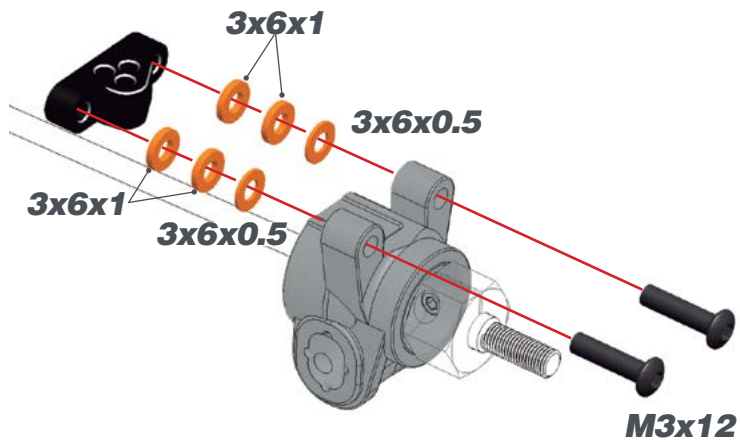

STEP 34

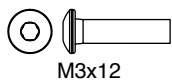
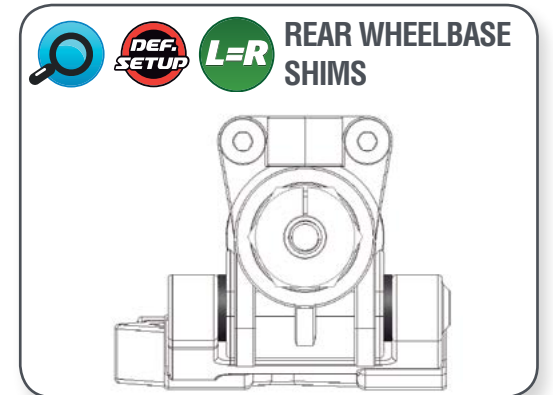
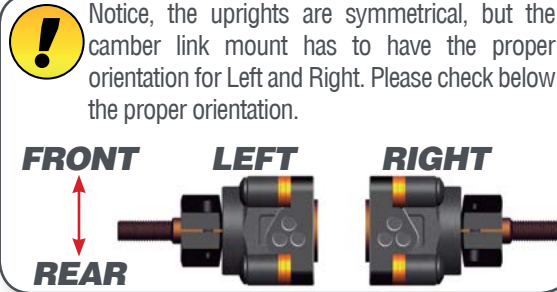

STEP 35 **BAG 6**

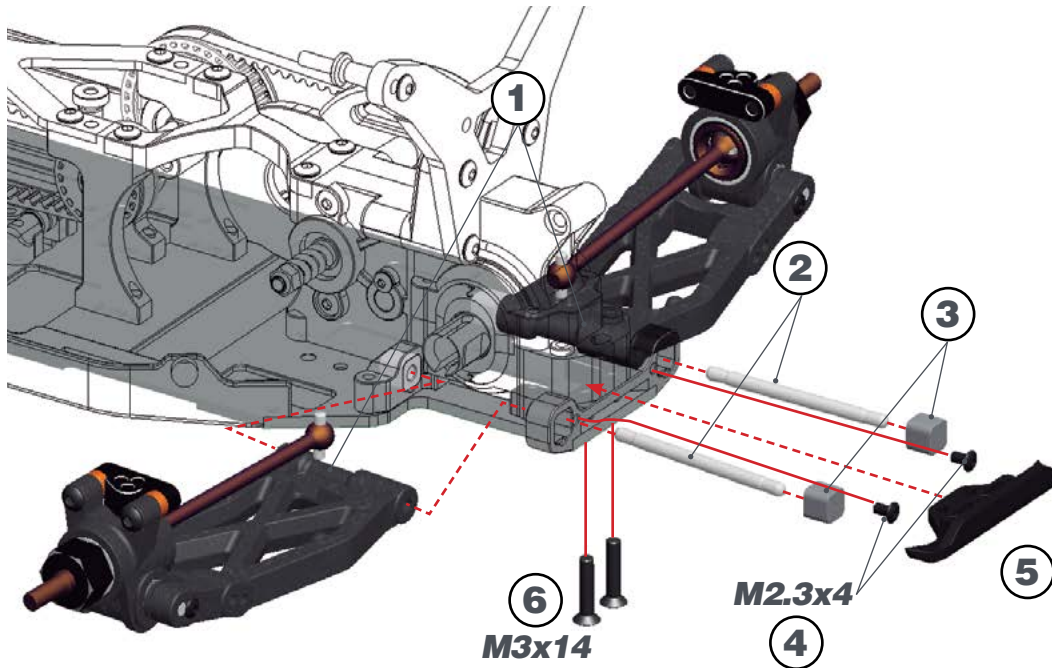

L=R DEF. SETUP REAR SUSPENSION INSERTS

Below is a diagram of every possible orientation of the complete 7 inserts system. You are able to move 0.5 or 1 degree in any direction from center. We also have 2 special inserts to fill 0.5° left and right offset, by 1° height, as seen in the diagram. Depending on your setup, the range of toe in is 1°, up to 5°. The anti squat range is -1 (pro Squat) up to 3° anti-squat. The default is centered inserts in both the FR FR toe block and RR RR toe block. This produces 3° toe in and 1° anti squat.

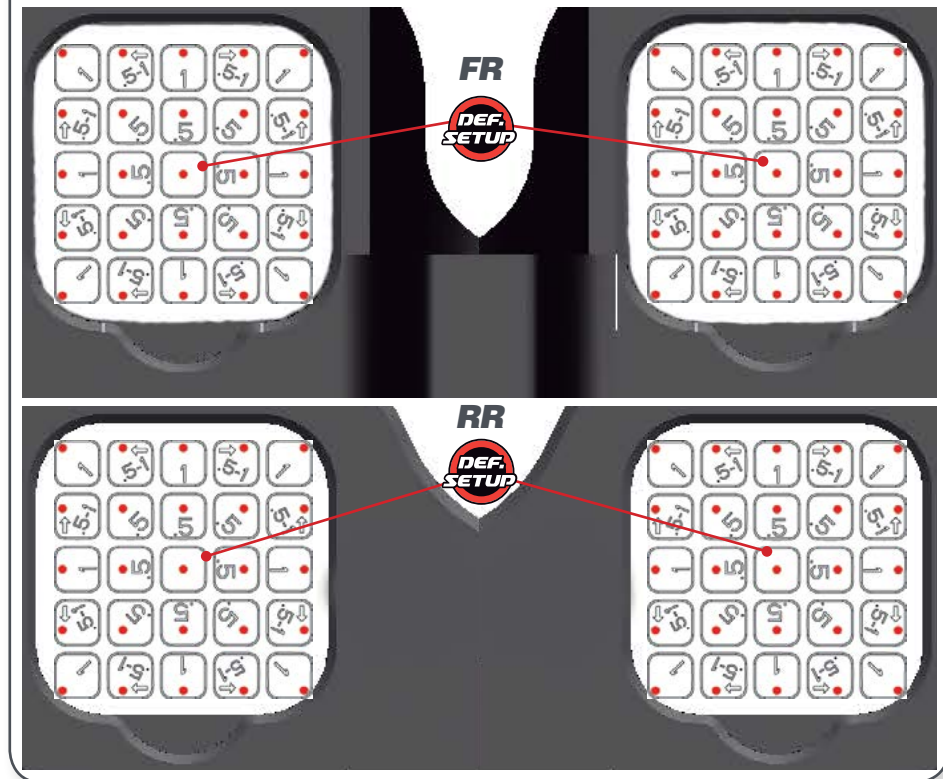

SIMPLIFIED EXPLANATION OF THE REAR SUSPENSION INSERTS

Example A: RR FR toe block inserts are 0°, RR RR toe block inserts are also 0°. This instance will produce 3° toe in and 1° anti-squat. This is default setting.

Example B: RR FR toe block inserts have been changed to centered 0.5° UP. The inserts in the RR RR toe block remain 0°. This will produce 3° toe in and 1.5° anti-squat.

Example C: RR FR toe block inserts remain 0°. The RR RR toe block inserts have been changed to 0.5° centered inward. This will product 2.5° toe in and 1° anti-squat.

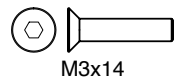

STEP 36

STEP 37

36.1

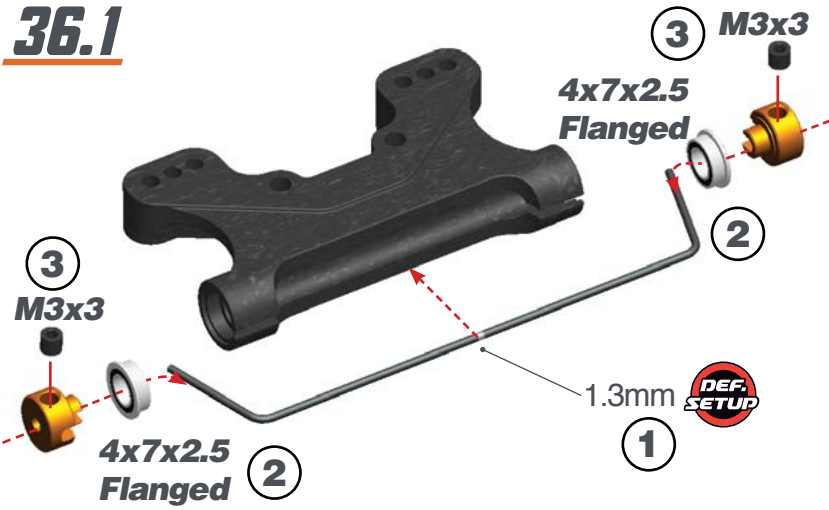

36.2

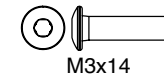
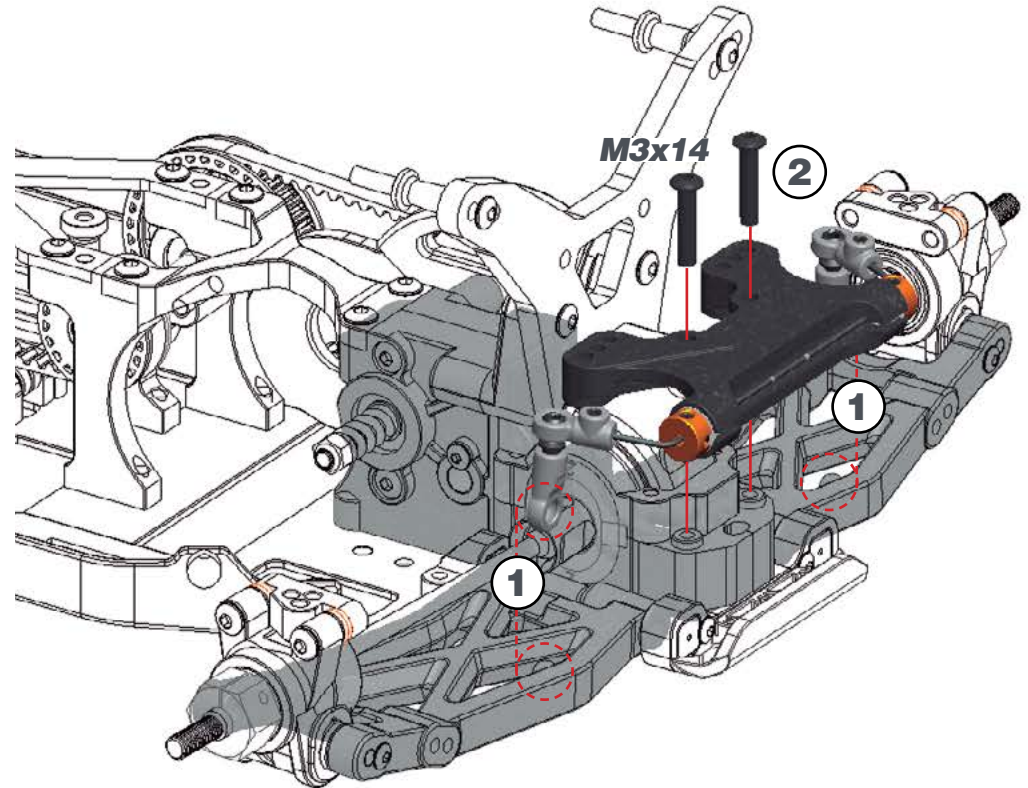
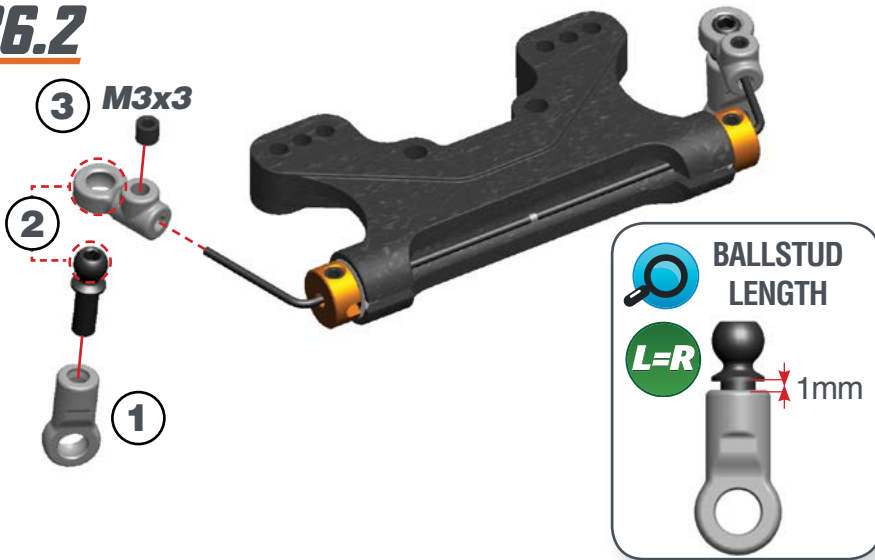

STEP 38

38.1



DEF. SETUP **L=R** FRONT CAMBERLINK LENGTH

27.5 mm

38.2

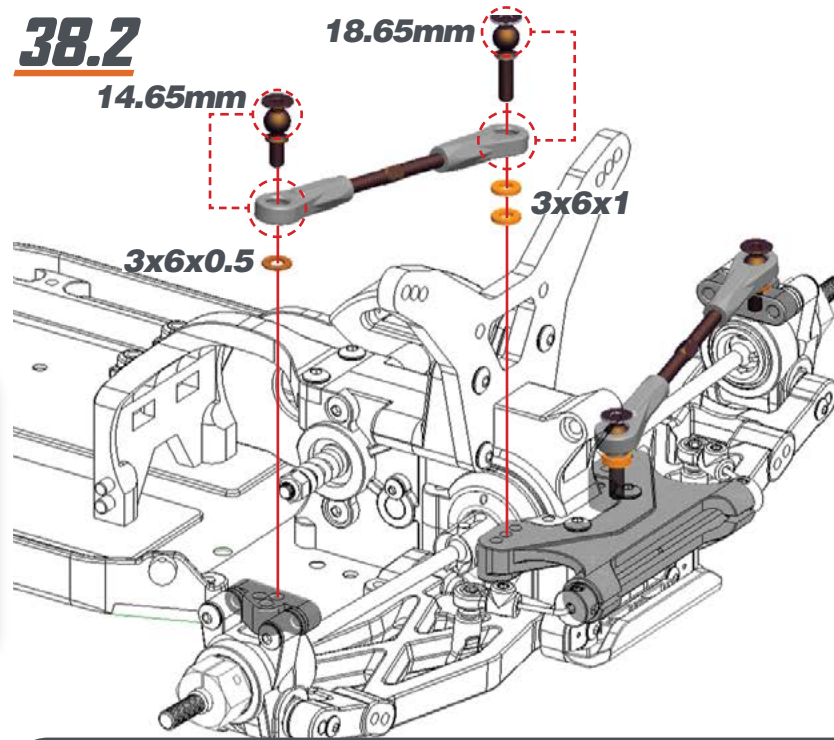

BALLSTUD LENGTH

18.65mm

14.65mm

DEF. SETUP **L=R** CAMBERLINK INNER & OUTER DEFAULT POSITION



STEP 39

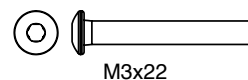
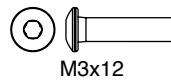
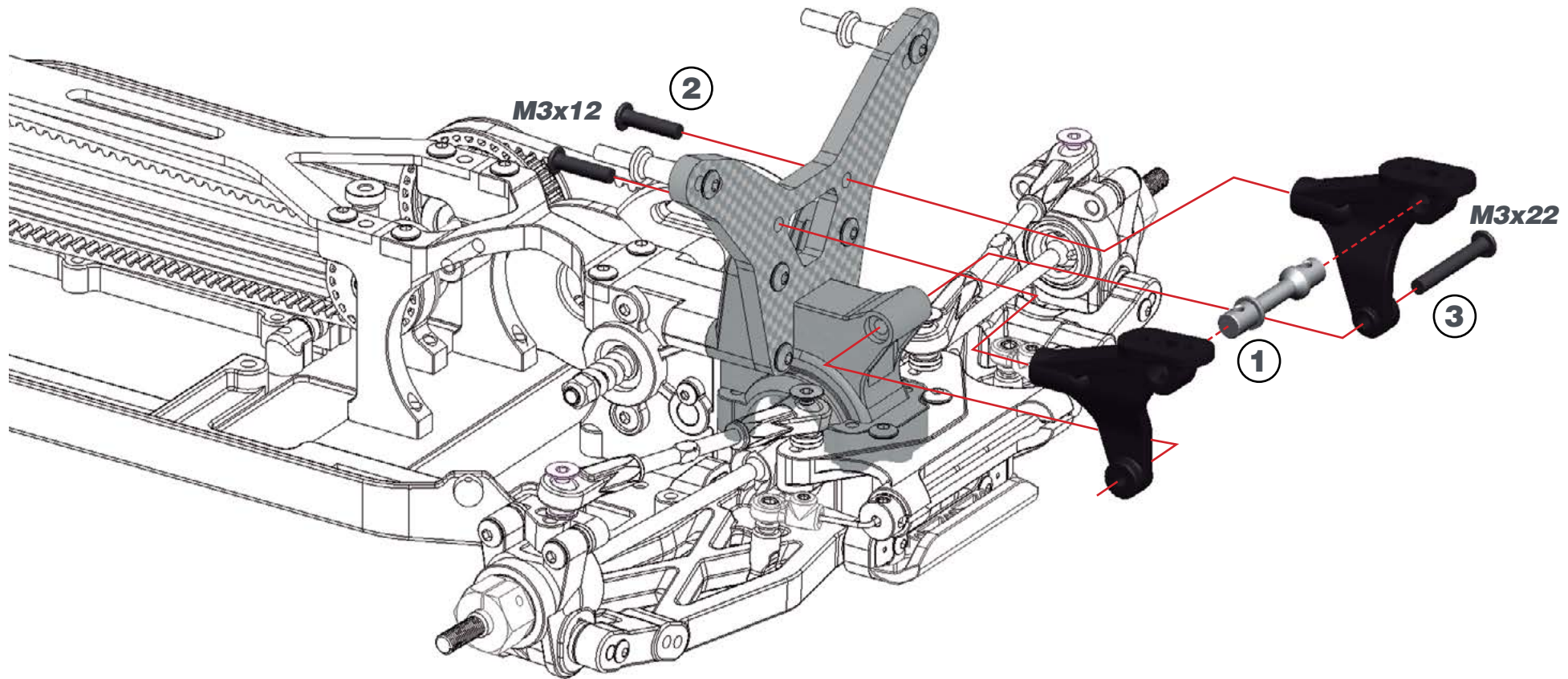

STEP 40 BAG 7

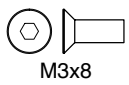
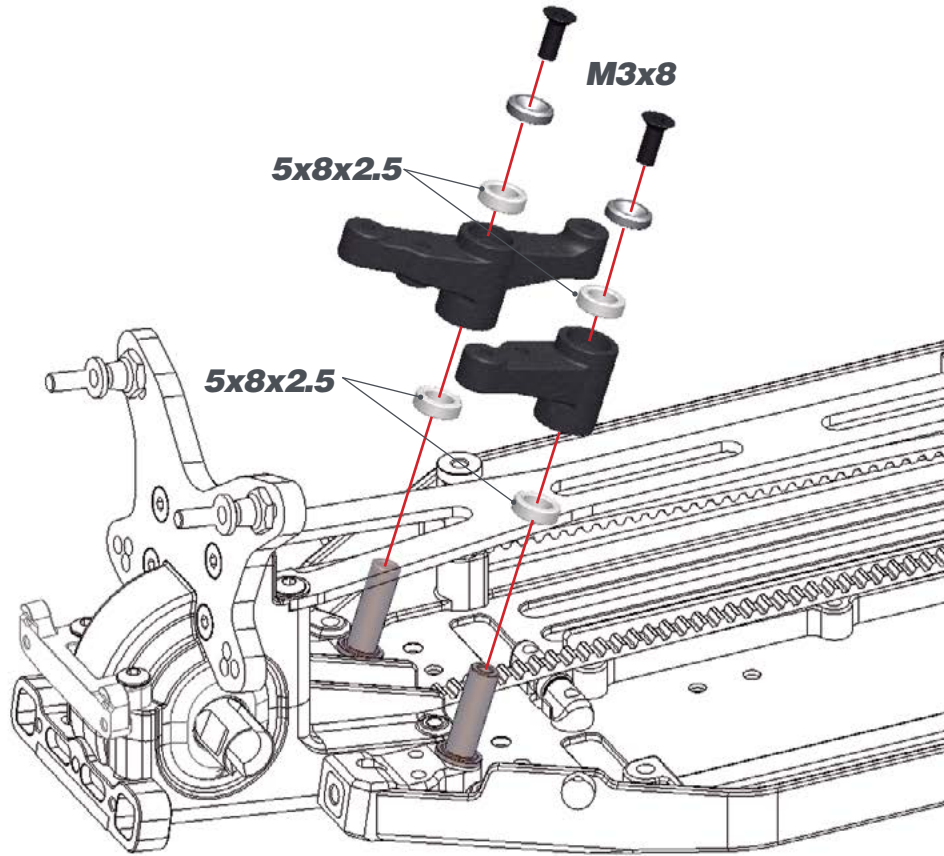

STEP 41

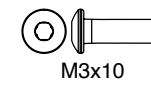
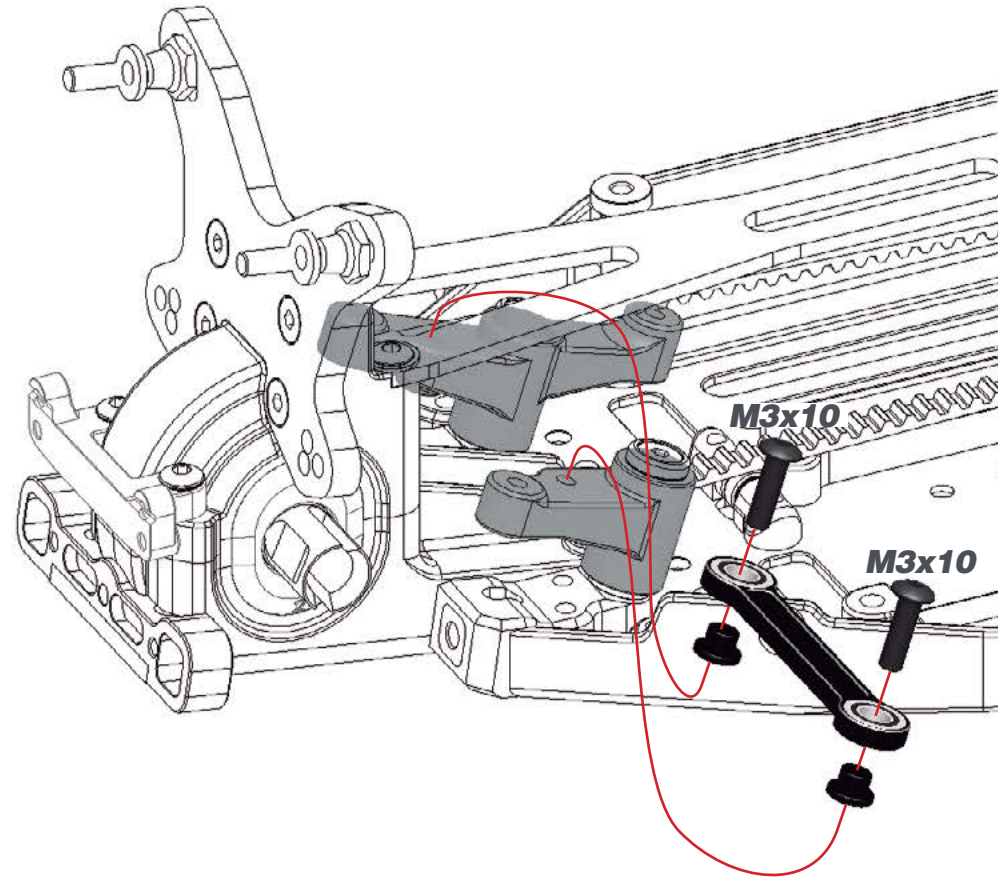

STEP 41

42.1

- 1- Check how many teeth your servo spline has (23 or 25) and then install the correct lever.
- 2- Make sure to put the servo in neutral before mounting the lever.

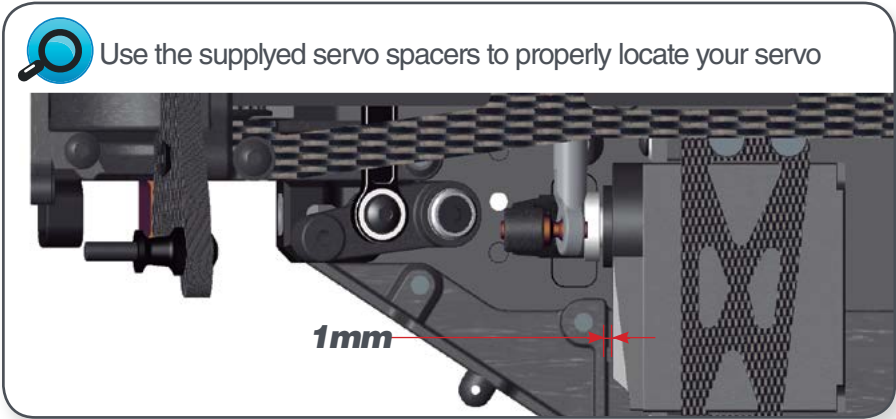
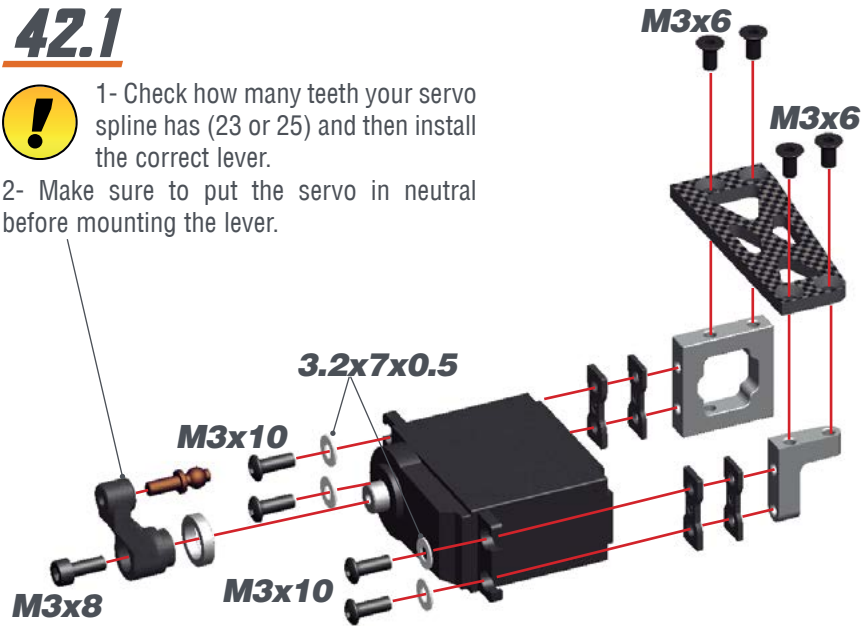

42.2

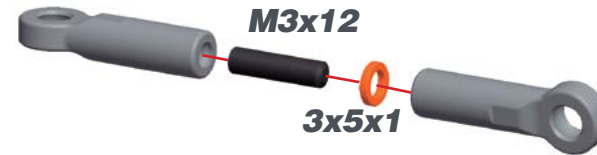

STEERING LINK LENGTH
The length may differ slightly per servo-brand.

42.3

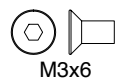
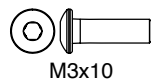
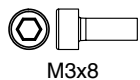
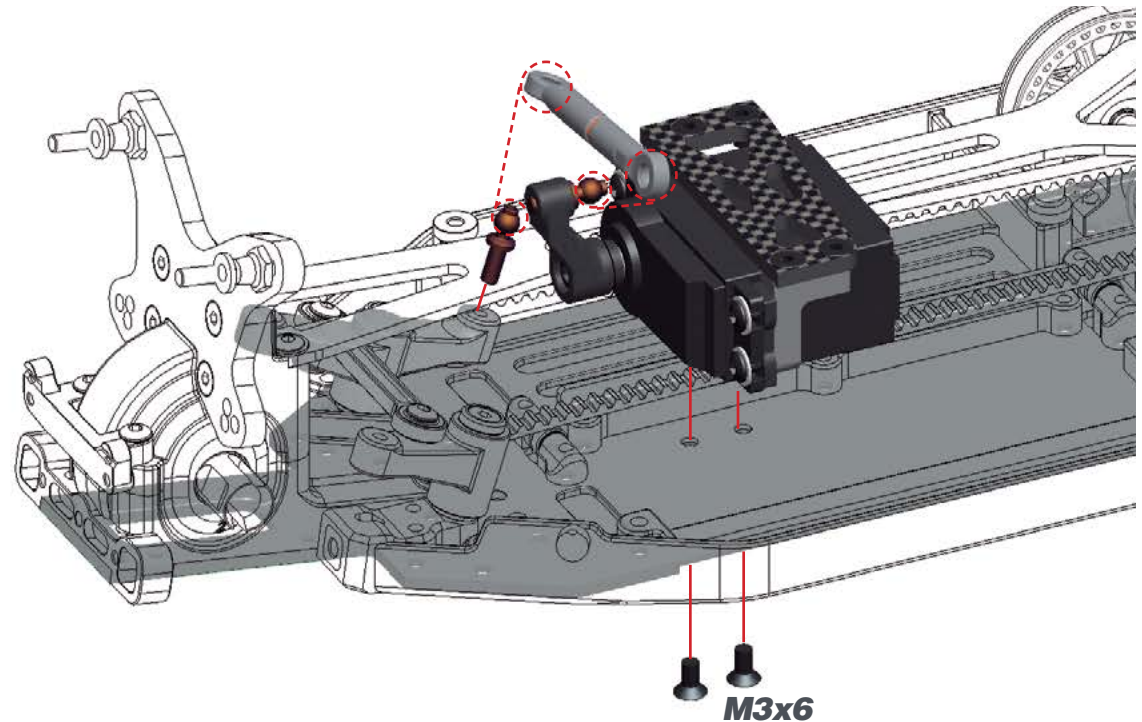

STEP 43 **BAG 8**

43.1

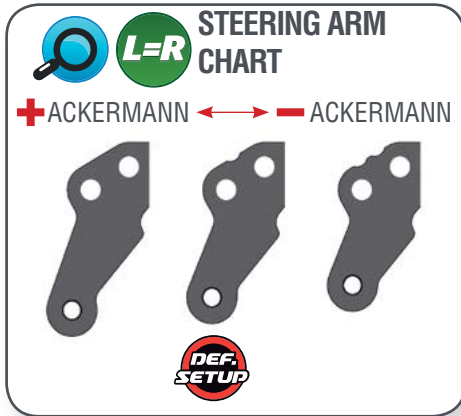

43.2



42.4



43.3



- 1- Place the caster shims in the bushings
- 2- Place the bushings and shims onto the casterblock.
- 3- Slide the steering block assembly onto the casterblock and fix with the M3x12 screws.

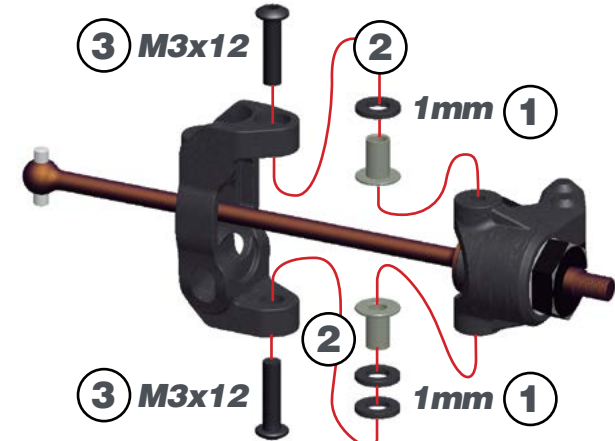

L=R

CASTER BLOCK INSERTS CHART

The front default caster is 10°, using the 0° caster block insert. You can add or decrease caster, using the inserts supplied in the kit. It is possible to adjust the caster angle at the caster block, from 5° to 15° degree's, in 2.5° to 5° increments.

- **Caster**

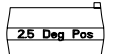
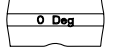
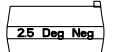
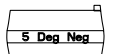

+ **Caster**

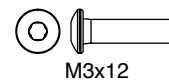
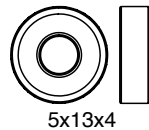
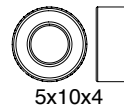
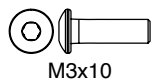
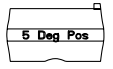

STEP 45 **BAG 9**

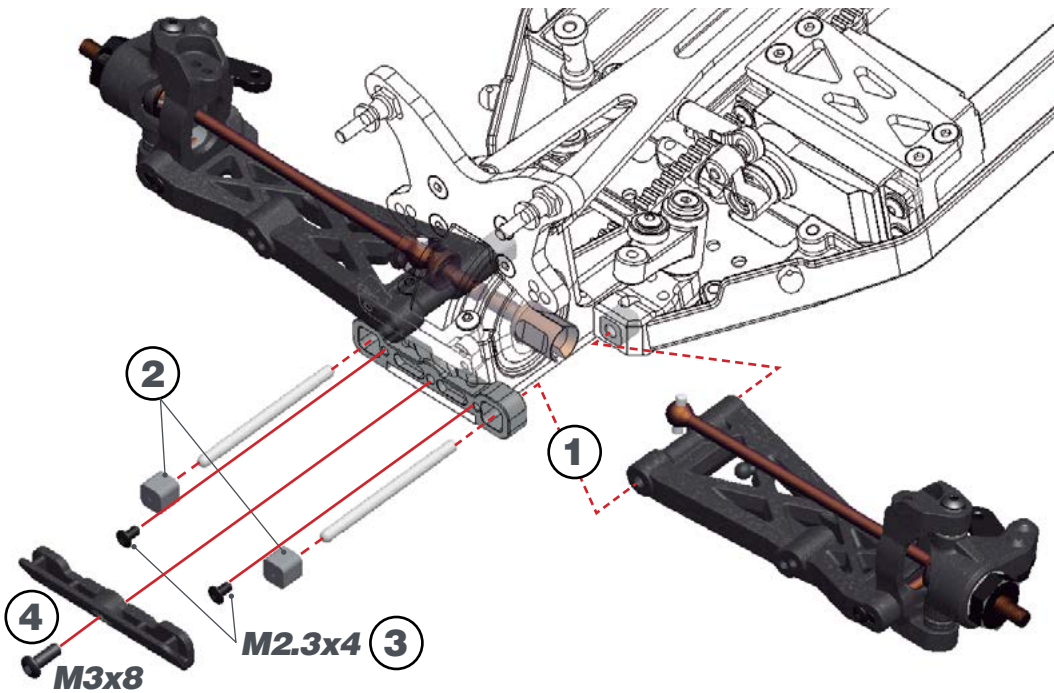

SIMPLIFIED EXPLANATION OF THE FRONT SUSPENSION INSERTS

Example A: FR/RR toe block inserts are 0°, FF/FF toe block inserts are 0°. This instance will produce 0° toe angle, and 8° degrees of kickup

Example B: FR/RR toe block inserts are 0°, FF/FF toe block inserts are 0.5° up. This instance will produce 0° toe angle, and 8.5° degrees of kickup

Example C: FR/RR toe block inserts are 0.5° in, FF/FF toe block inserts are 0°. This instance will produce 0.5° toe out angle, and 8° degrees of kickup.

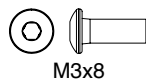
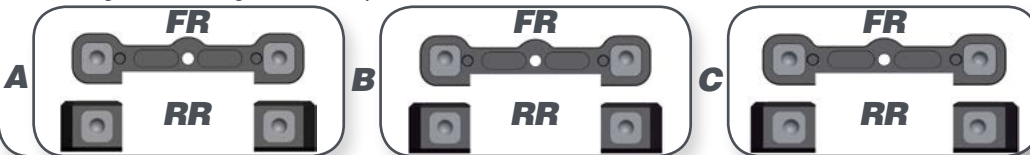

L=R **DEF. SETUP** **FRONT SUSPENSION INSERTS**

Below is a diagram of every possible orientation of the complete 7 insert system. You are able to move 0.5 to 1 degree in any direction from center. We also have two special inserts to fill 0.5° left and right offset, by 1° height as shown in the diagram.

Depending on your setup, inboard toe angle is -2° to +2°. The kickup range is from 6° to 10° kickup at the inner hinge pin. The default is centered inserts in both the FR/RR and FF/FF toe blocks. This produces 0° toe angle and 8° kickup.

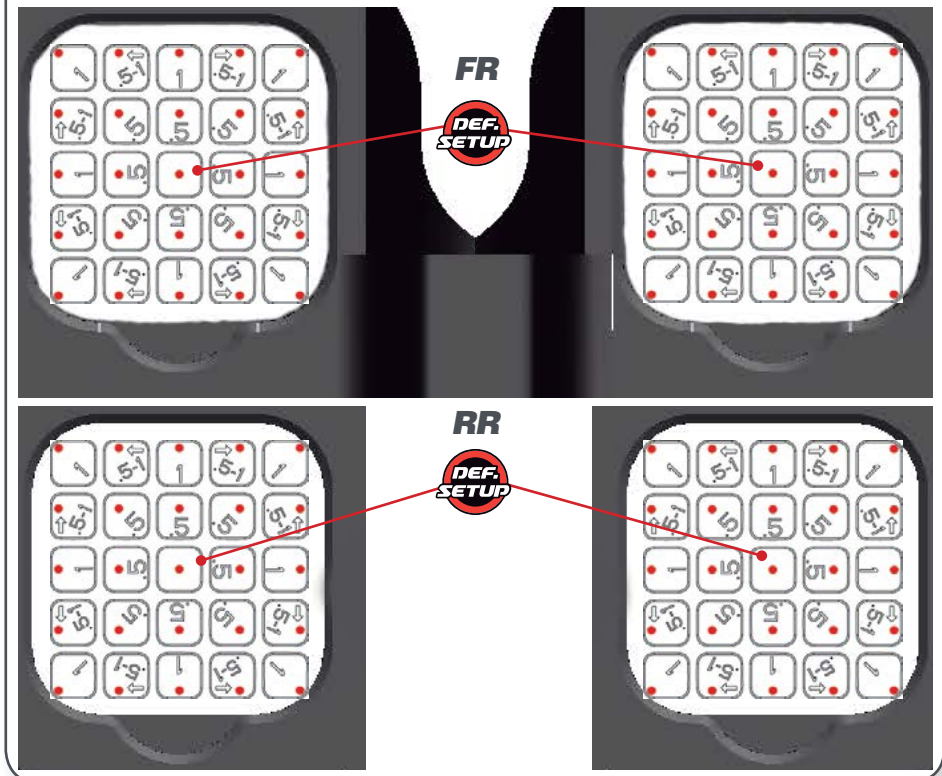

STEP 46

46.1

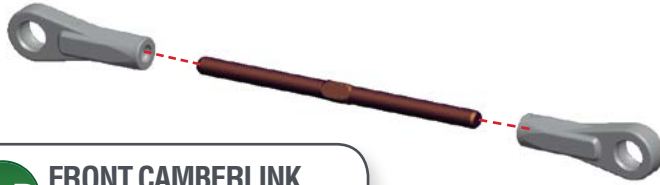

FRONT CAMBERLINK LENGTH

DEF. SETUP **L=R**

27.9 mm

46.2

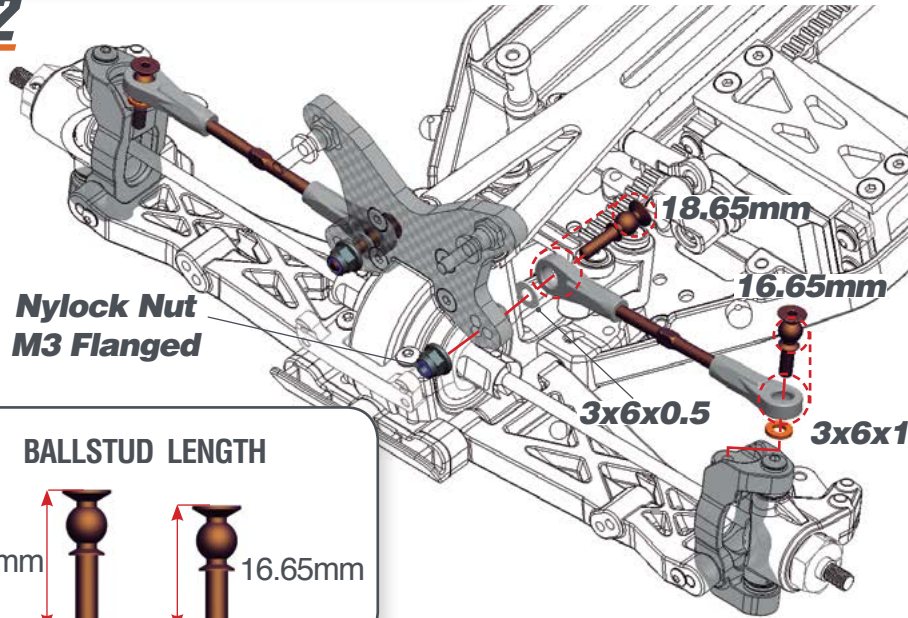

BALLSTUD LENGTH

18.65mm

16.65mm



STEP 47

47.1

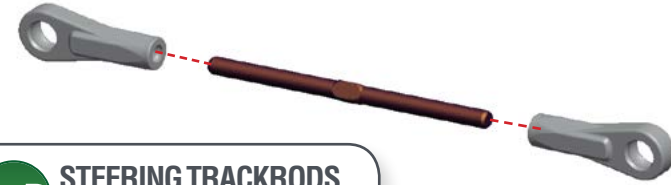

STEERING TRACKRODS LENGTH

DEF. SETUP **L=R**

27.5 mm

47.2

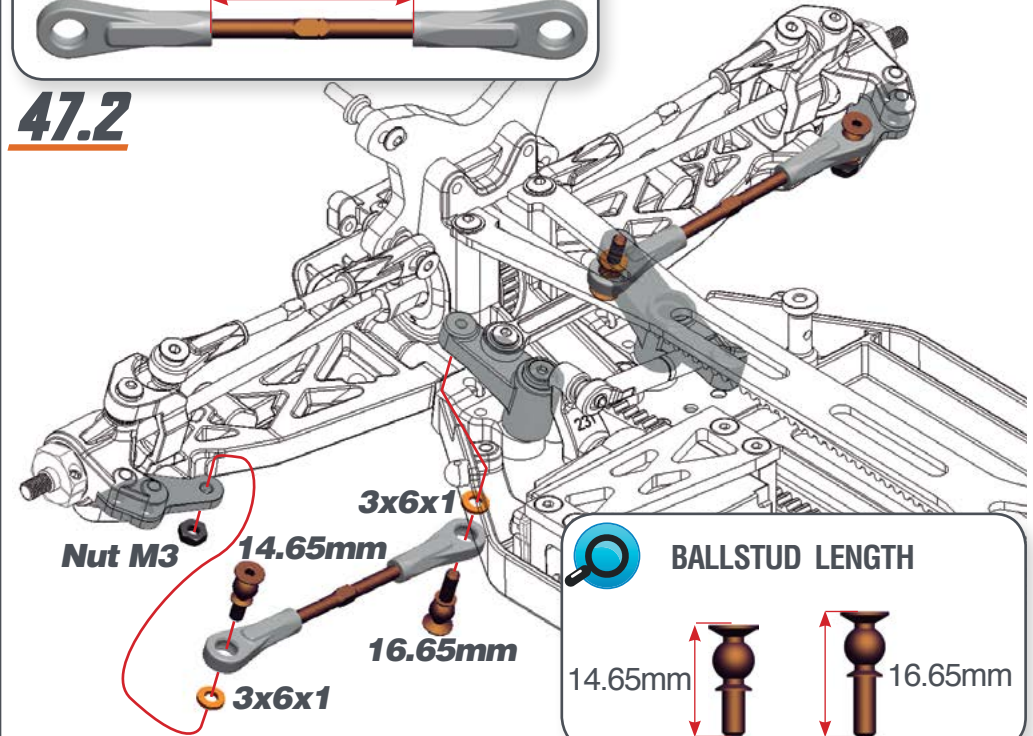

BALLSTUD LENGTH

14.65mm

16.65mm



STEP 48

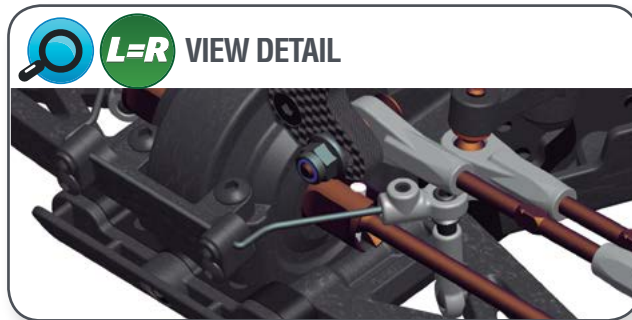
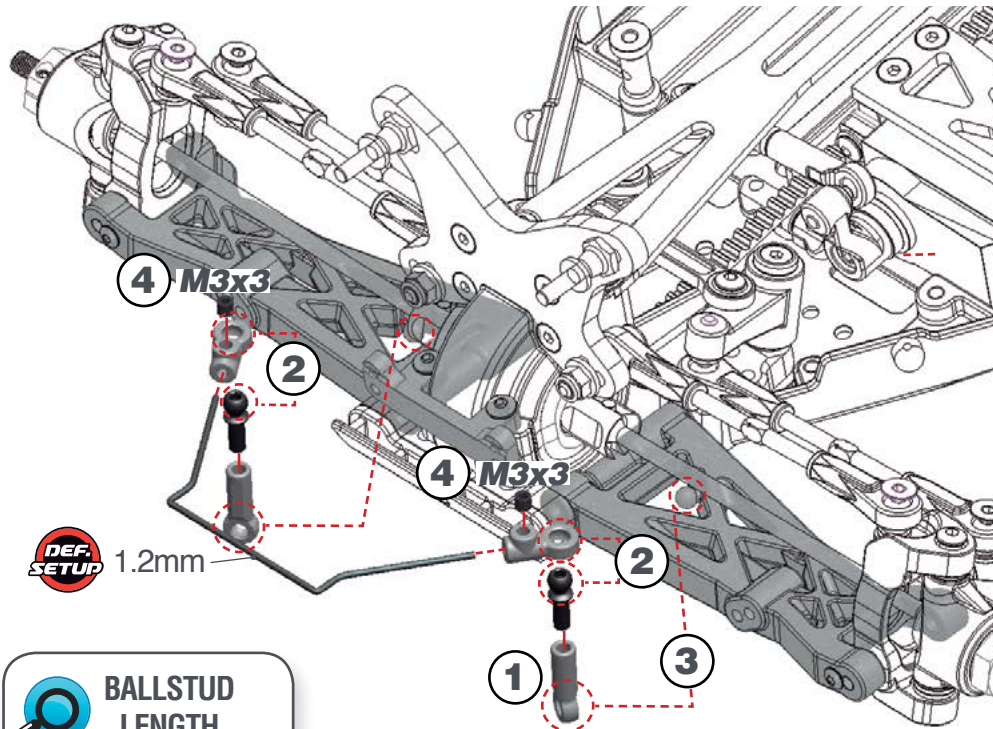

STEP 49

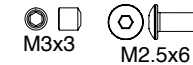
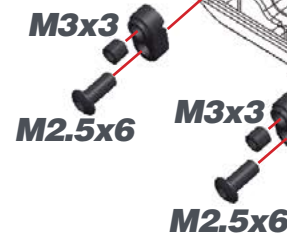
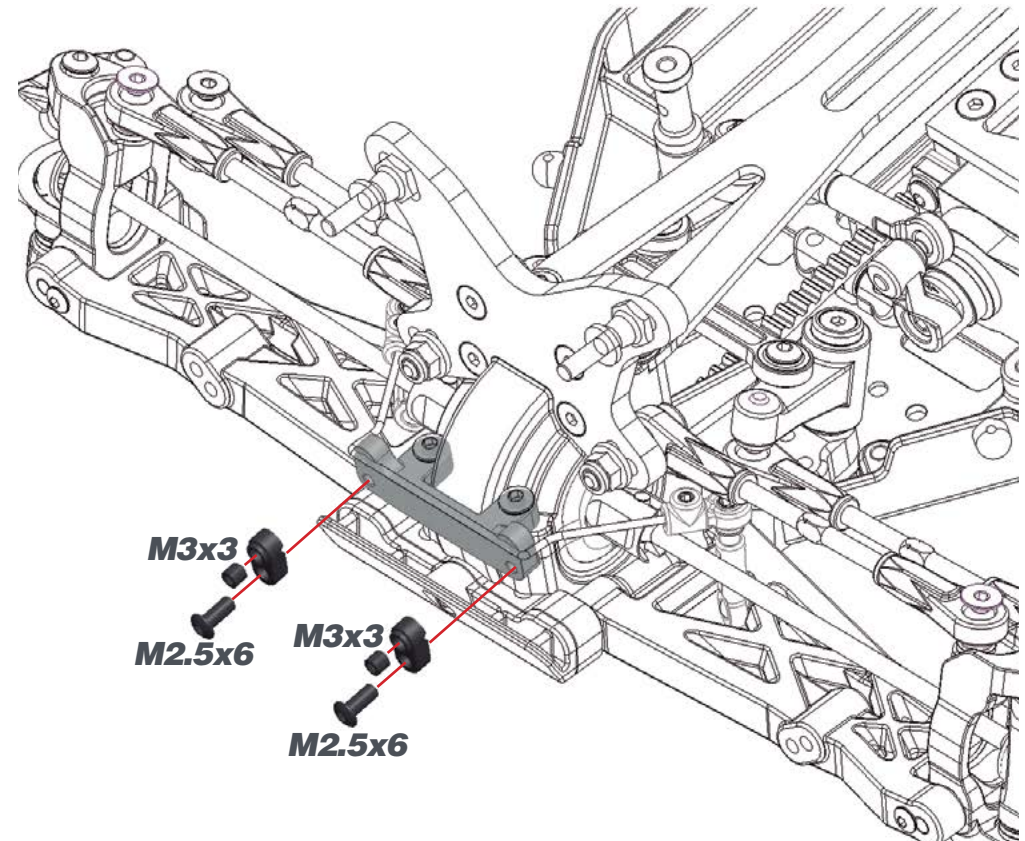

STEP 50 BAG 10 FR SHOCKS / BAG 11 RR SHOCKS / STEP 51

50.1

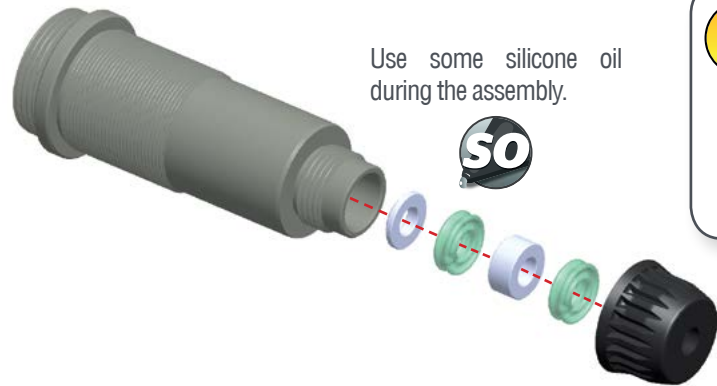

Use some silicone oil during the assembly.

SO



Note the correct orientation of the shock spacers.

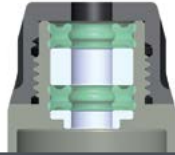

50.2

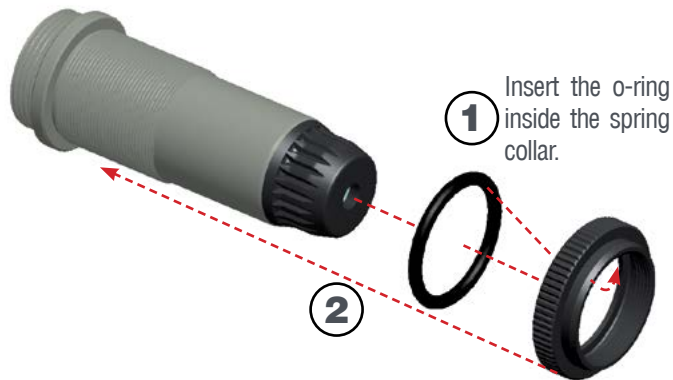

1 Insert the o-ring inside the spring collar.



Note the correct position of the o-ring.



51.1

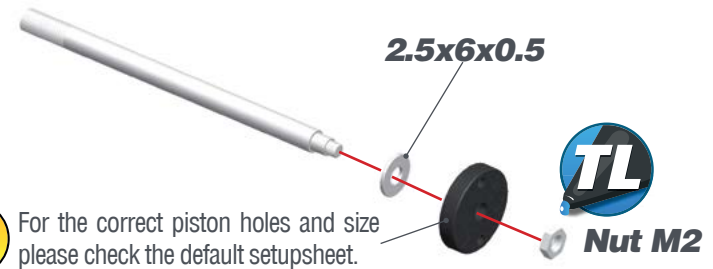

2.5x6x0.5

TL

Nut M2



For the correct piston holes and size please check the default setupsheet.

SHOCK PISTONS CHART



FR

DEF. SETUP

RR

DEF. SETUP

51.2



SO

Use some silicone oil during the assembly.

1.25mm
0.75mm

EYELETS LENGTH



FR

RR

17.5mm



19.75mm



2.5x6x0.5



Nut M2

STEP 52

52.1

1- Fill up with silicone oil fully using the silicone oil supplied in the kit. For the correct cst value please check the default setupsheet.

2- Extend the shockrod fully

3- Move the shockrod slowly up and down to let ALL air bubbles escape.

4- Apply the gasket and cap and close fully.



52.2

1-Bleed: push the shock-rod all the way in slowly, to allow excessive oil to escape.

2- With shockrod fully in, mount the o-ring and screw.

M2.3x4

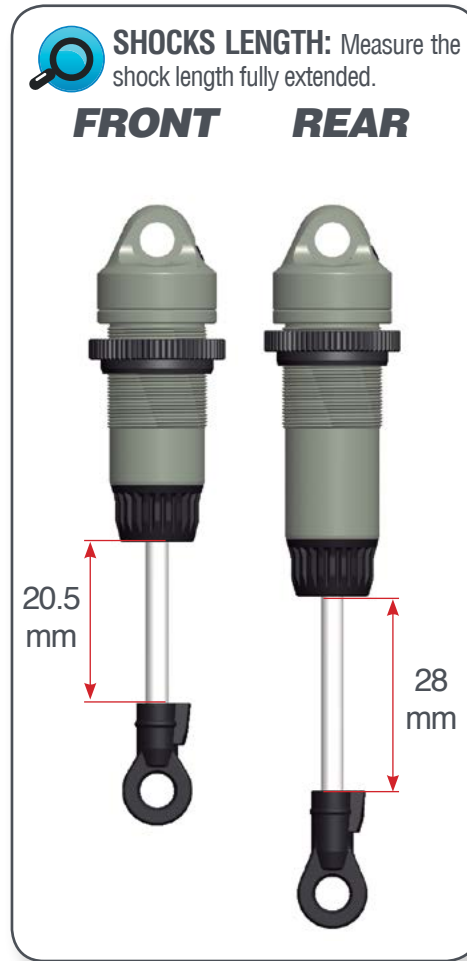

STEP 53

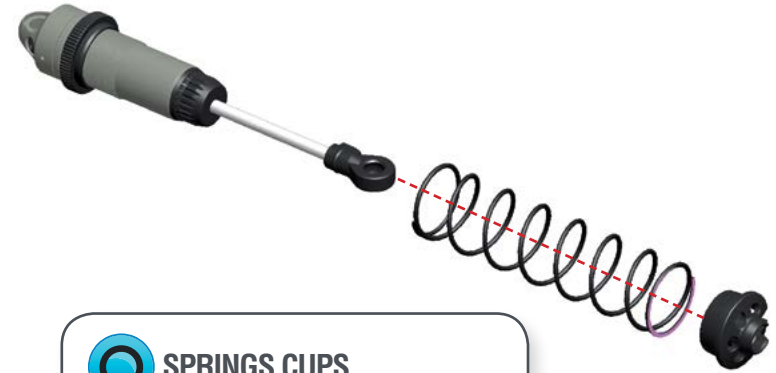

Assemble the spring and spring-cup (align correctly) to complete the shock.

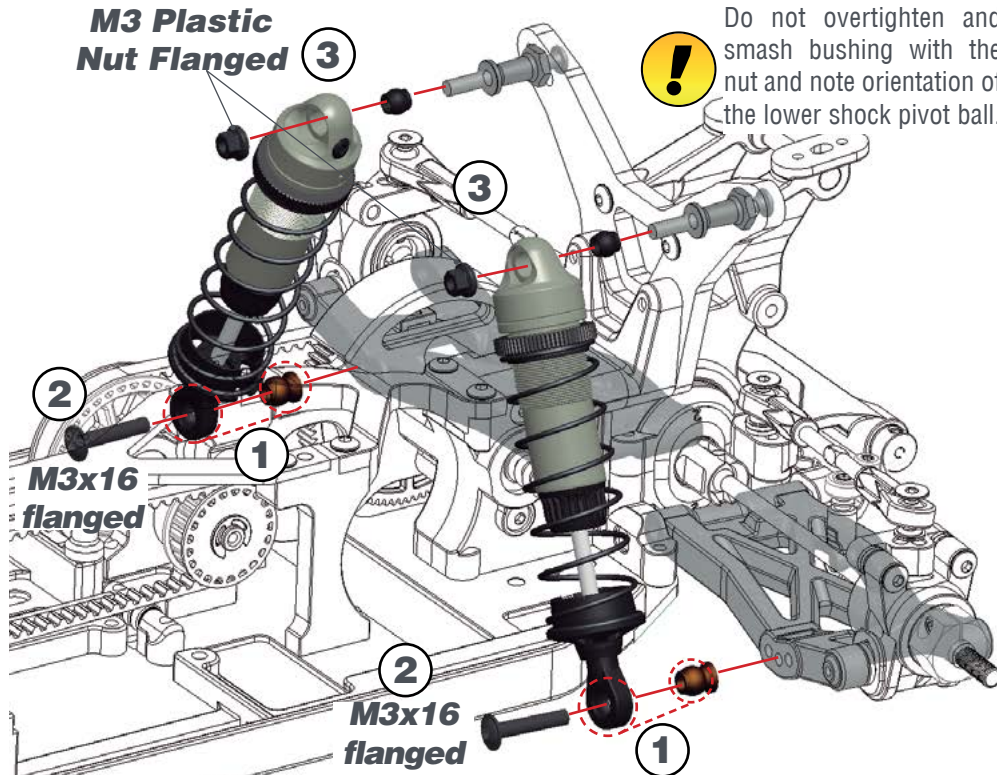

M2.3x4

STEP 54 **BAG 12**



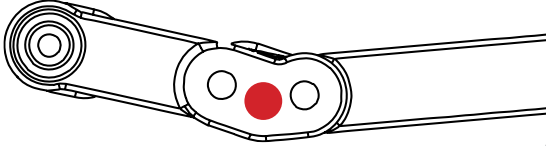
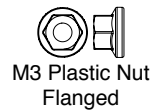
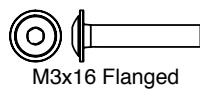

   **REAR SHOCKS**
DEFAULT POSITION

STEP 55

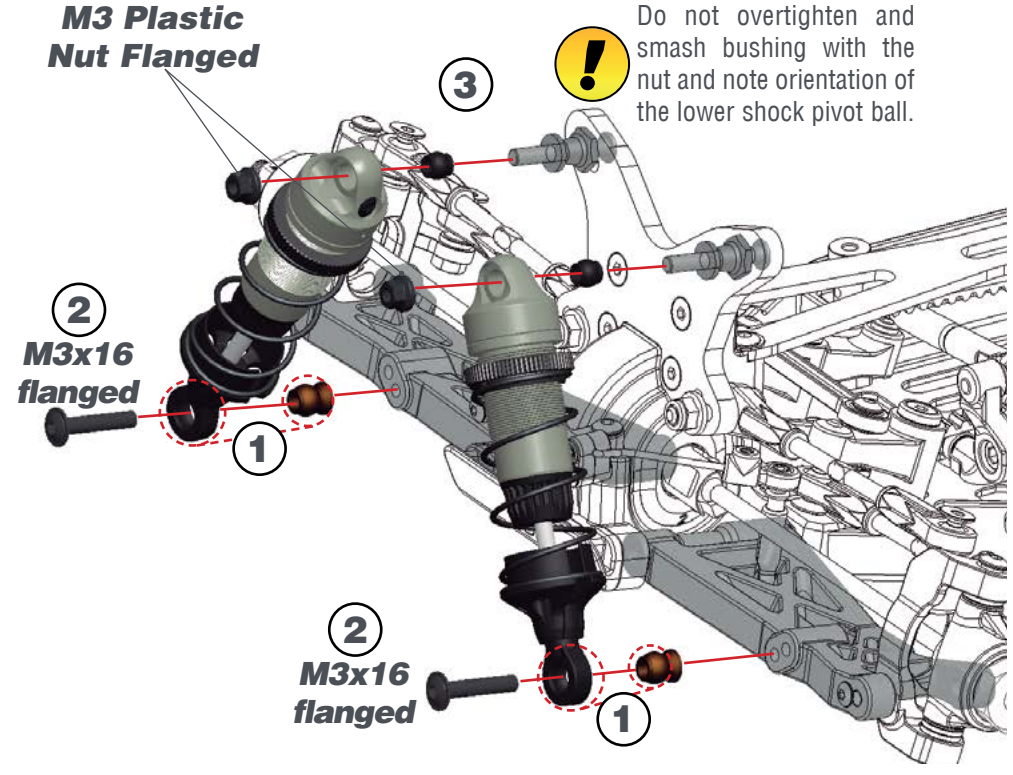

   **FRONT SHOCKS**
DEFAULT POSITION

STEP 56

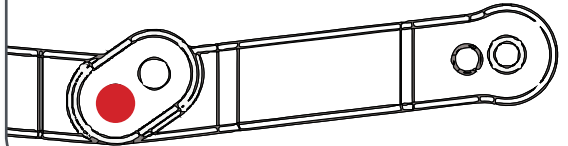
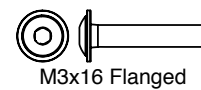

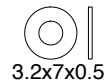
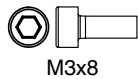
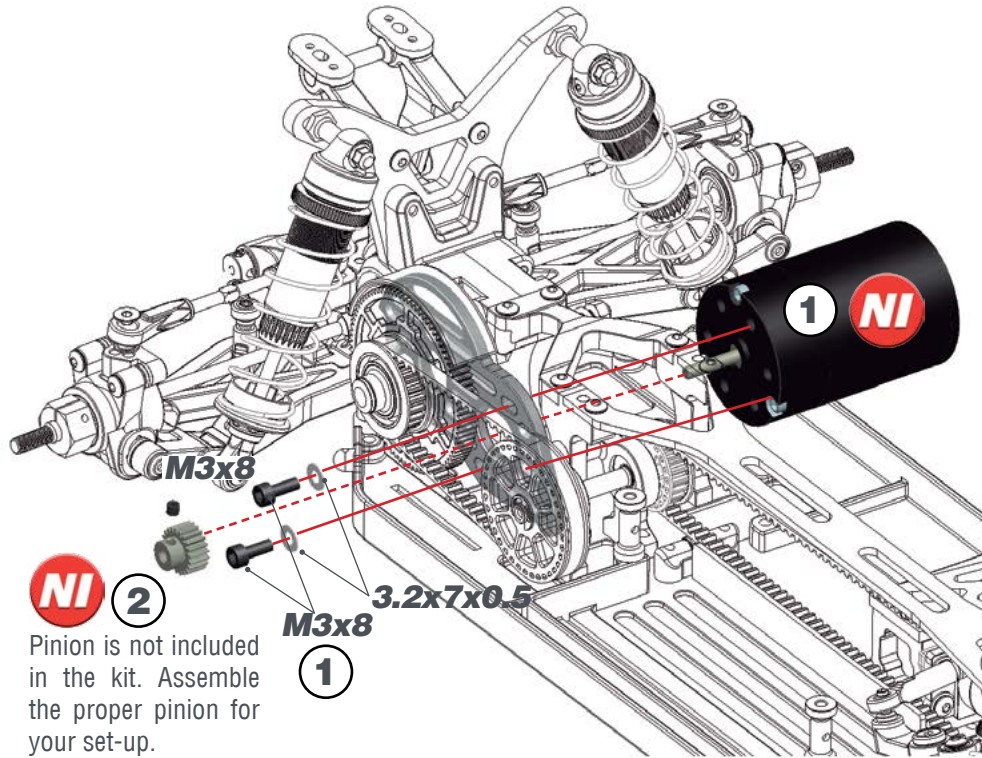
STEP 57



Use double sided tape to mount the ESC and RX to the chassis.

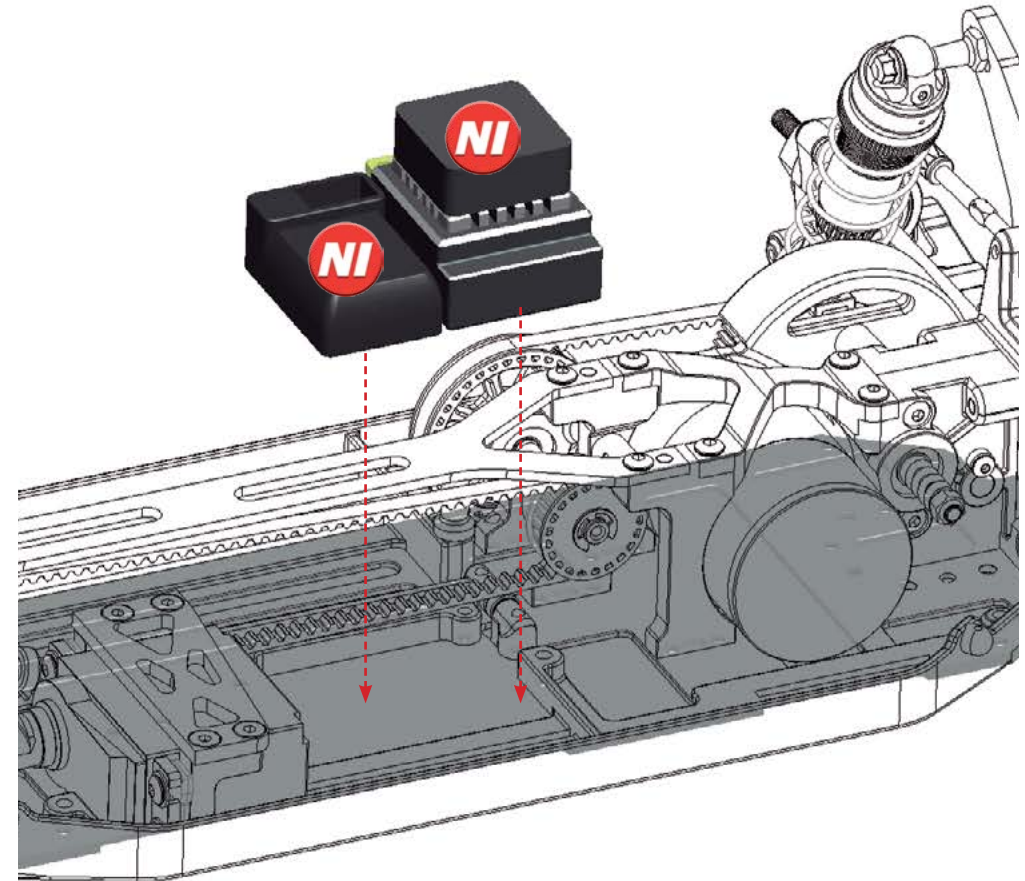

STEP 58

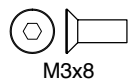
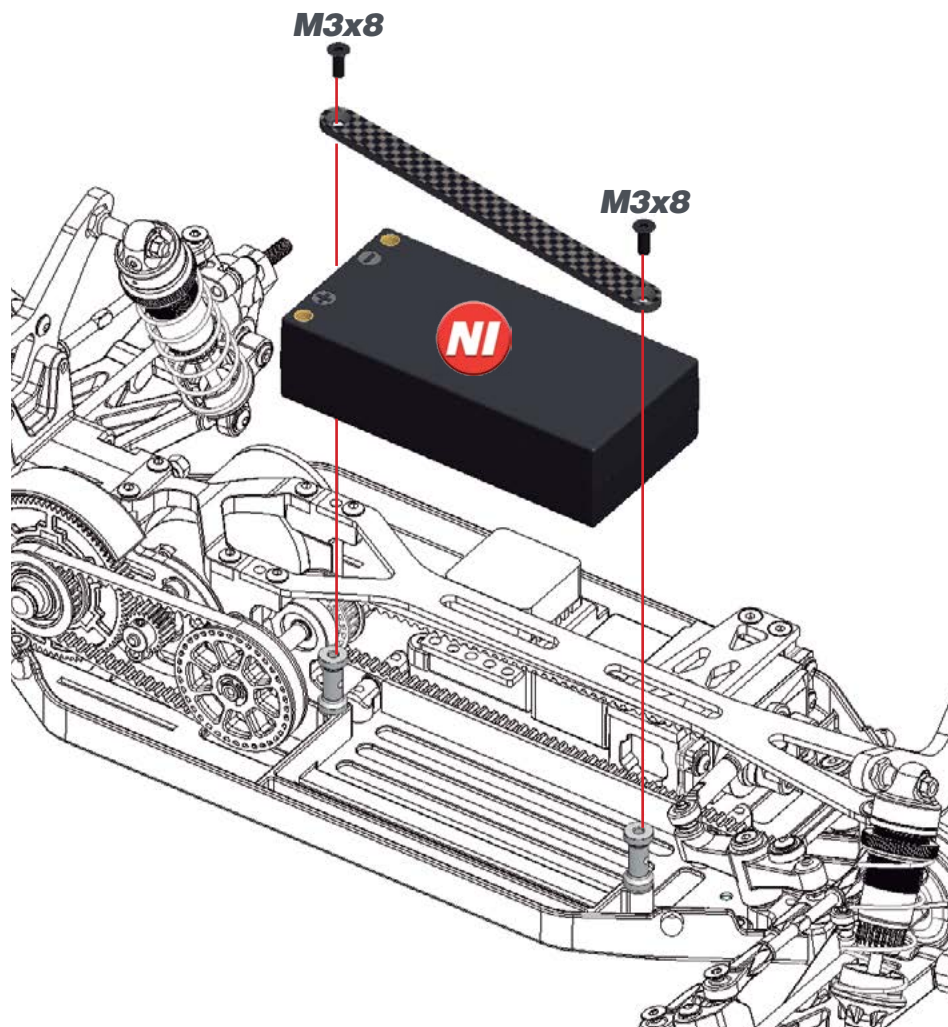

STEP 59

ANGLED WING SPACERS CHART

0°		DEF. SETUP
2°		
4°		
6°		
8°		

FRONT ↔ **REAR**

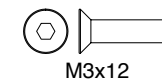
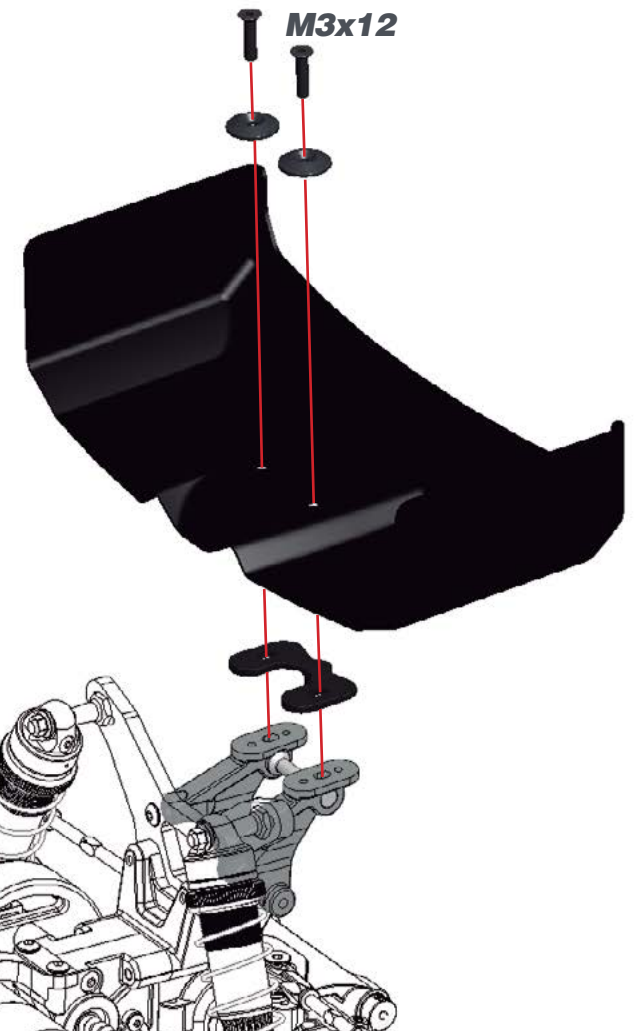

STEP 60



- 1- Rims included in the kit.
- 2- Rubber tyres not included in the kit.
- 3- Be sure to glue your rubber tyres to the wheels using Cyanoacrylate glue.

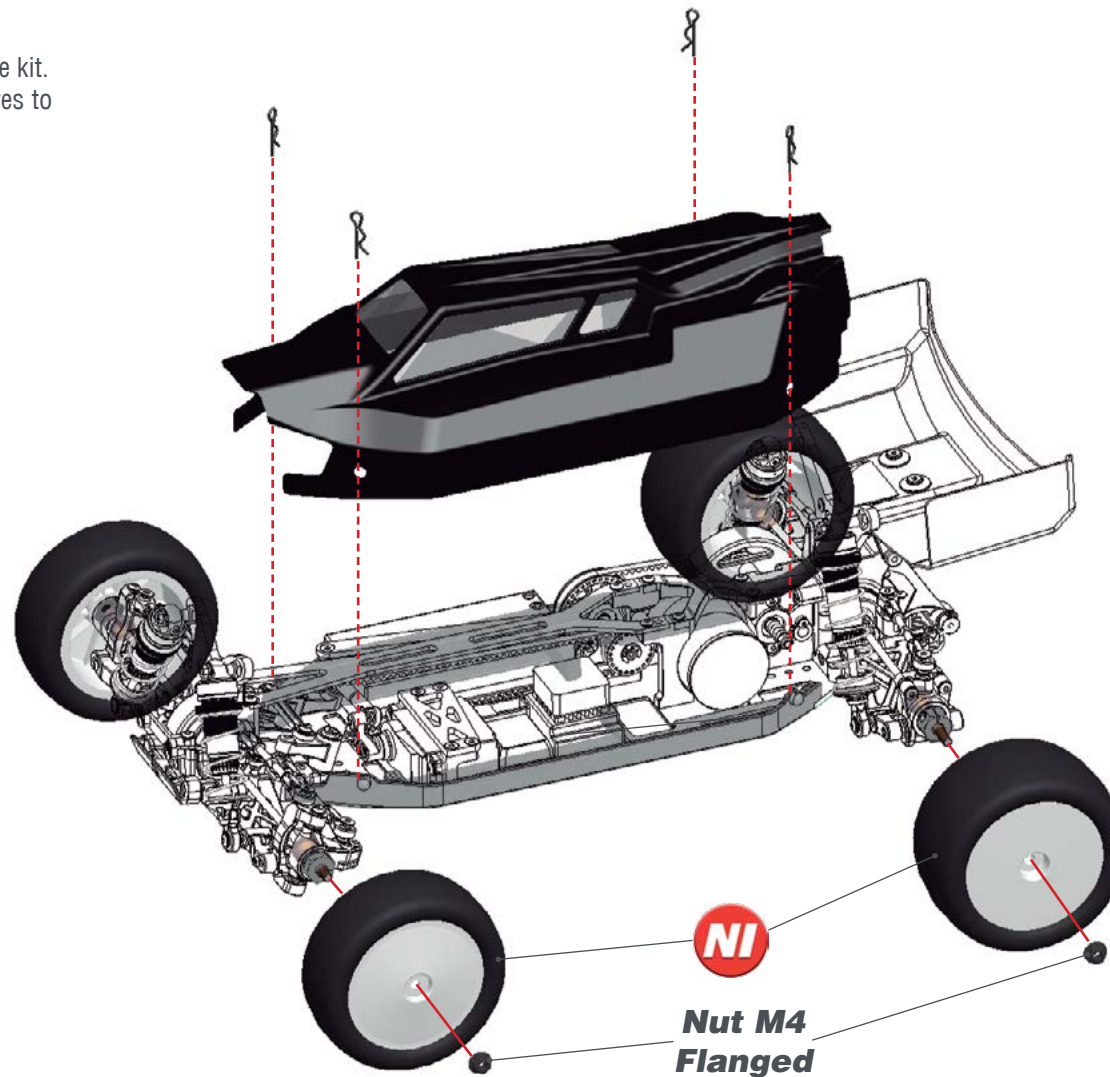

Nut M4
Flanged

INDEX

FRONT AND REAR DIFFERENTIAL EXPLODED VIEW	38
SHOCKS EXPLODED VIEW	39
ANTI-ROLL BARS EXPLODED VIEW	40
CENTER CHASSIS ASSEMBLY EXPLODED VIEW	41
MID-FRONT TRANSMISSION EXPLODED VIEW	42
STEERING SERVO ASSEMBLY EXPLODED VIEW	43
REAR TRANSMISSION EXPLODED VIEW	44
FRONT SUSPENSION EXPLODED VIEW	45
REAR SUSPENSION EXPLODED VIEW	46
FINAL ASSEMBLY EXPLODED VIEW	47
TEAM SERPENT NETWORK	48

500790 Geardiff set 51T SRX2 Gen3



- 411069 Differential balls steel 1/8" (12)
- 411107 Diff balls. 1/8 ceramic (12)
- 500259 Differential balls carbide 1/8
- 500256 Thrustbearing carbide balldiff SRX2
- 500781 Geardiff housing 51T LF SRX2 Gen3
- 500782 Diff pully balldiff 51T LF SRX2 Gen3
- 500791 Balldiff set 51T SRX2 Gen3
- 500793 Geardiff nut alu (4) SRX2

- 500794 Diff pin 14T alu (2) SRX2
- 500168 Diff ring balldiff (2) SRX2
- 500169 Balldiff outrdrive male SRX2
- 500170 Balldiff outrdrive female SRX2
- 500172 Balldiff bolt (2) SRX2
- 500173 Balldiff thrustbearing SRX2
- 500187 Balldiff T-nut (2) SRX2
- 500448 Geardiff housing alu SRX

- 500459 Oneway pulley 34T fr SRX4
- 500460 Balldiff pulley 34T fr SRX4
- 500484 Geardiff 34T fr SRX4
- 500485 Geardiff rr alu SRX
- 500731 Diff pully balldiff 51T SRX2 Gen3
- 500758 Geardiff outrdrive long (2) SRX2 Gen3
- 500782 Diff pully balldiff 51T LF SRX2 Gen3
- 500790 Geardiff set 51T SRX2 Gen3



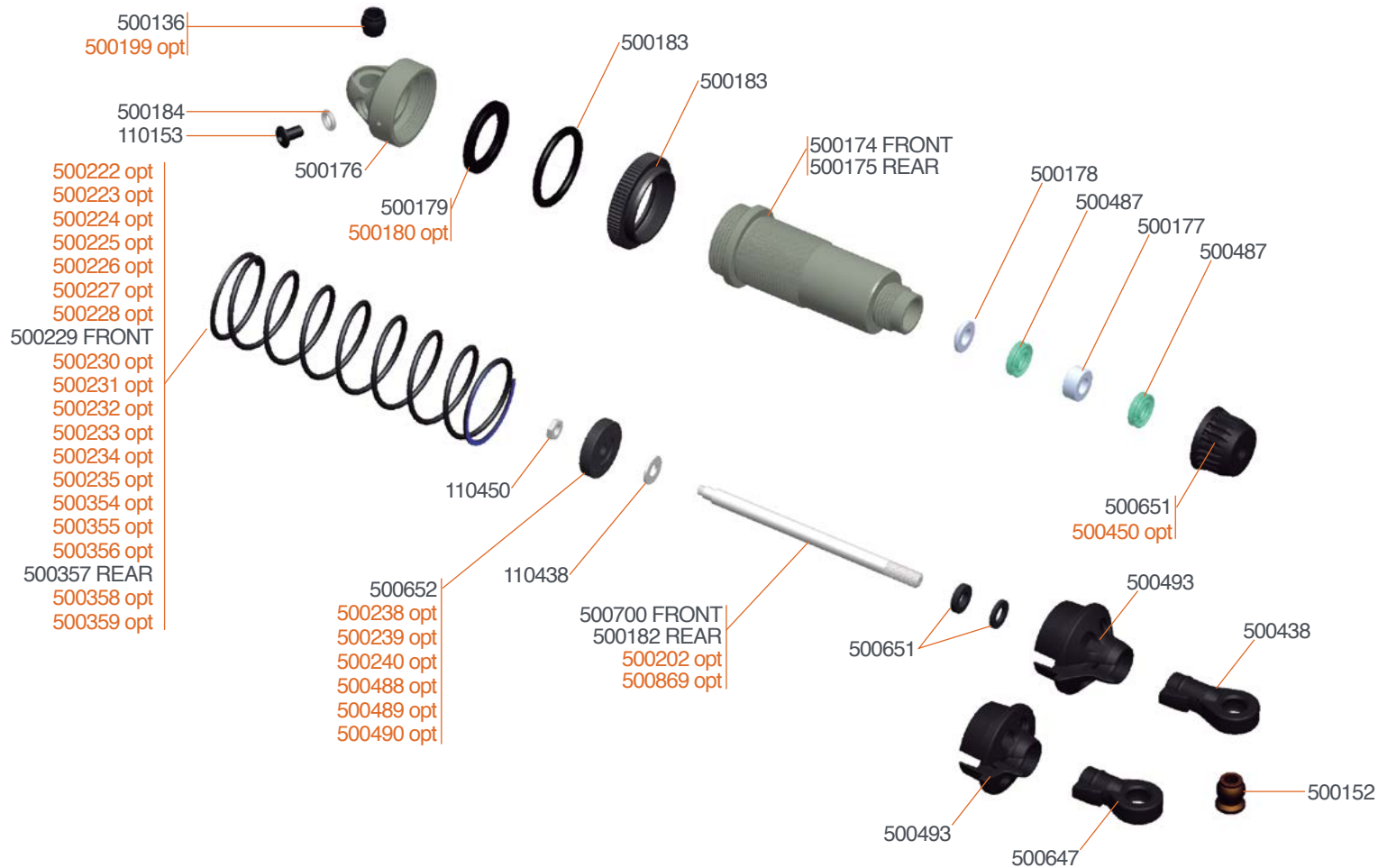

- 500450 Shock bottom cap alu (4) SRX
- 500488 Shock piston square machined 2-hole 1.3 (4)
- 500489 Shock piston square machined 3-hole 1.2 (4)
- 500490 Shock piston square machined 4-hole 1.1 (4)
- 500202 Shock shaft rr TiN coated (2) SRX2
- 500180 Shock membrame (4) SRX2
- 500222 Shock spring silver 2,5lbs fr (2) SRX2
- 500223 Shock spring black 2,65 fr (2) SRX2
- 500224 Shock spring orange 2,87lbs fr (2) SRX2
- 500225 Shock spring red 3,0lbs fr (2) SRX2
- 500226 Shock spring pink 3,15lbs fr (2) SRX2

- 500227 Shock spring blue 3,4lbs fr (2) SRX2
- 500228 Shock spring purple 3,5lbs fr (2) SRX2
- 500229 Shock spring green 3,7lbs fr (2) SRX2
- 500230 Shock spring orange 2,0lbs rr (2) SRX2
- 500231 Shock spring red 2,1lbs rr (2) SRX2
- 500232 Shock spring pink 2,2lbs rr (2) SRX3
- 500233 Shock spring blue 2,3lbs rr (2) SRX2
- 500234 Shock spring purple 2,4lbs rr (2) SRX2
- 500235 Shock spring green 2,5lbs rr (2) SRX2
- 500354 Shock spring orange 1.8lbs rr astro (2) SRX2
- 500355 Shock spring red 1.9lbs rr astro (2) SRX2

- 500356 Shock spring pink 2.0lbs rr astro (2) SRX2
- 500357 Shock spring blue 2.1lbs rr astro (2) SRX2
- 500358 Shock spring purple 2.2lbs rr astro (2) SRX2
- 500359 Shock spring green 2.3lbs rr astro (2) SRX2
- 500869 Shockshaft fr TiN coated (2) SRX Gen3
- 500199 Shock top bushing delrin (4) SRX2
- 500238 Shock piston conical 2 holes (4) SRX2
- 500239 Shock piston conical 3 holes (4) SRX3
- 500240 Shock piston conical 4 holes (4) SRX4



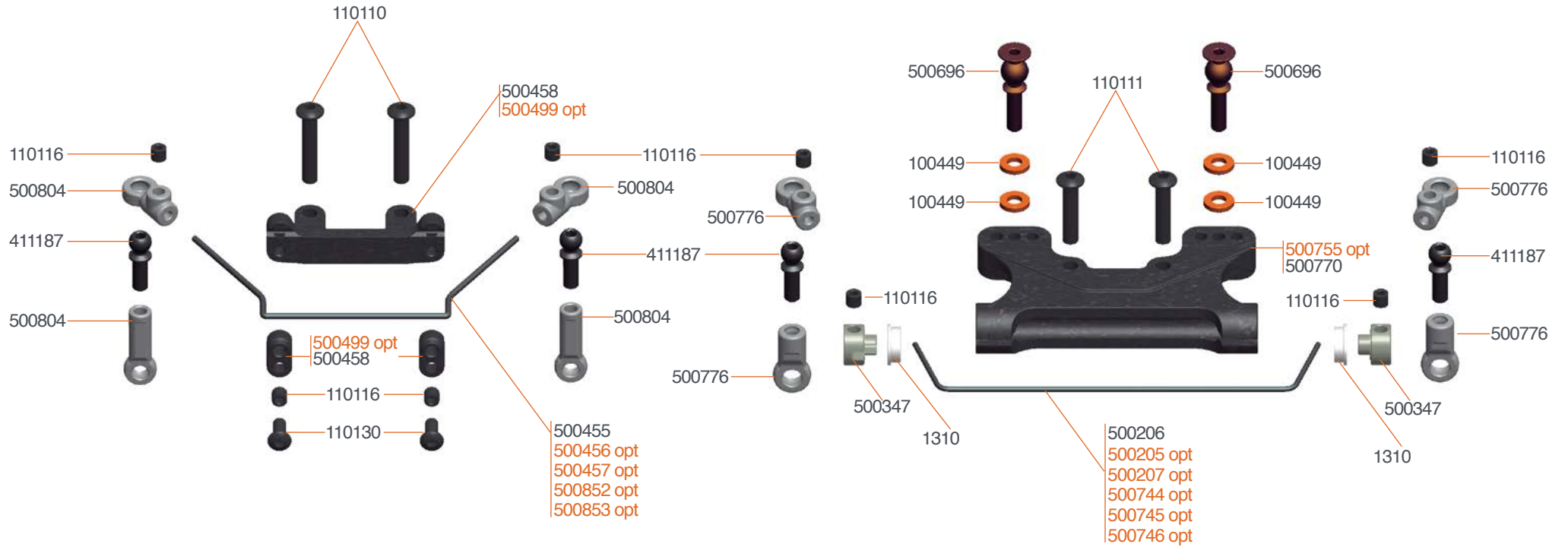

500205 Antiroll bar rr 1.1 SRX2
 500207 Antiroll bar rr 1.5 SRX2
 500456 Antiroll bar fr 1.3 SRX4
 500457 Antiroll bar fr 1.4 SRX4

500499 Antiroll bar mount fr alu SRX4
 500744 Antiroll bar 1.0 rr SRX2 Gen3
 500745 Antiroll bar 1.2 rr SRX2 Gen3
 500746 Antiroll bar 1.4 rr SRX2 Gen3

500770 Camberlink mount arb rr SRX2 Gen3
 500755 Camberlink mount rr alu SRX2 Gen3
 500852 Anti-Roll Bar 1.6mm fr SRX4 Gen3
 500853 Anti-Roll Bar 1.8mm fr SRX4 Gen 3

CENTER CHASSIS ASSEMBLY EXPLODED VIEW

SRX4
gen3

SERPENT

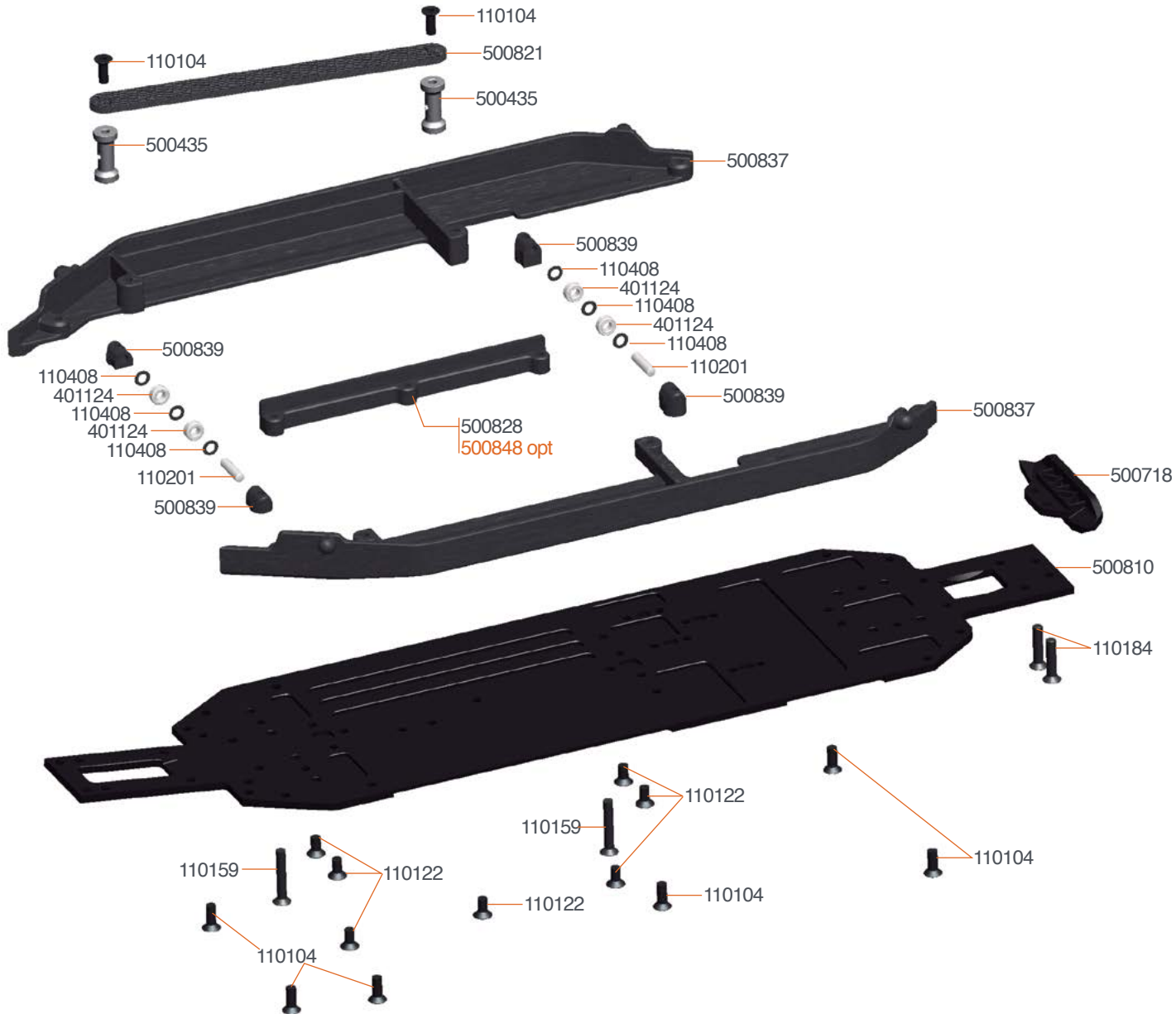

500739 motor weight rr SRX2 Gen3
500848 Battery Support ALU SRX4 Gen3

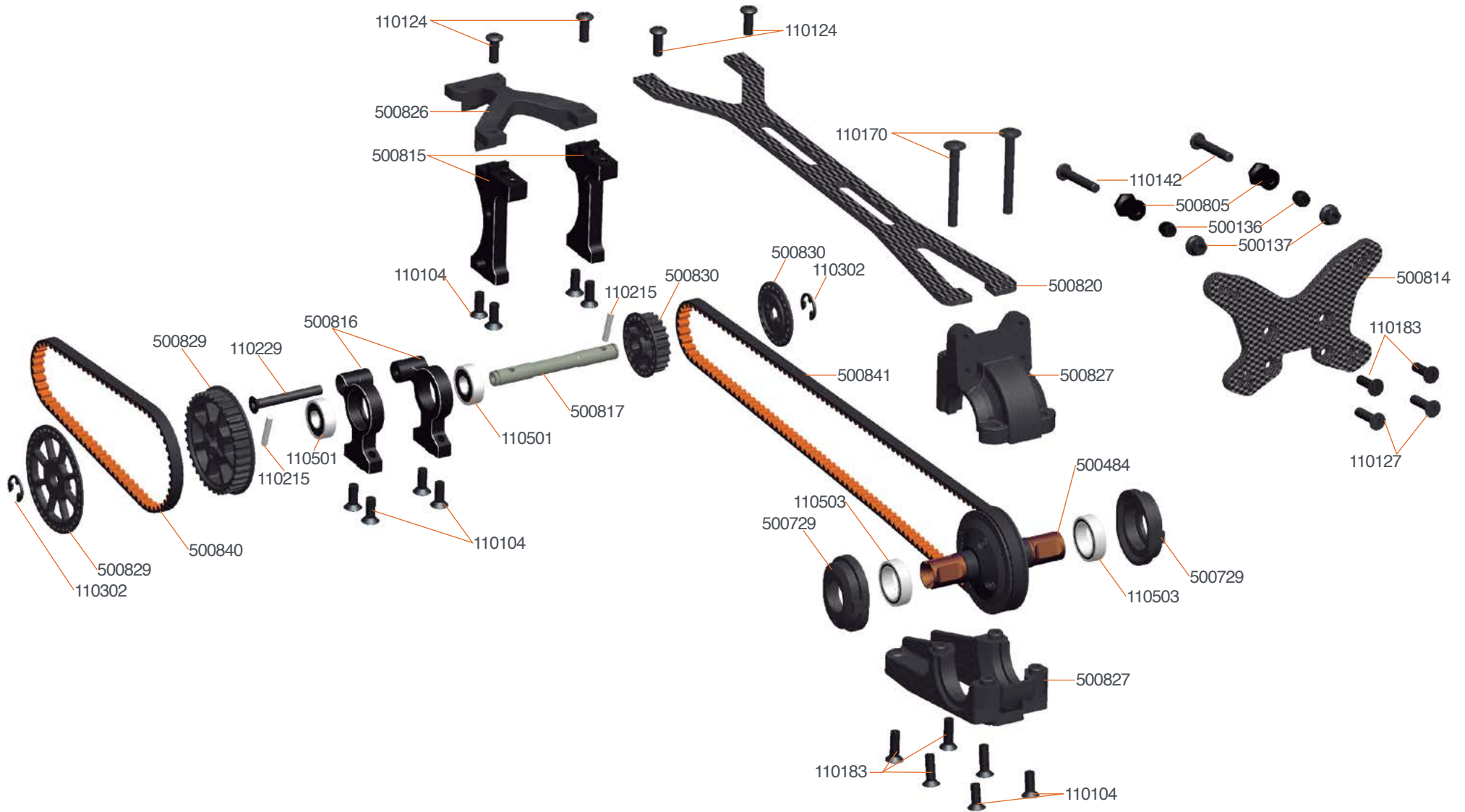

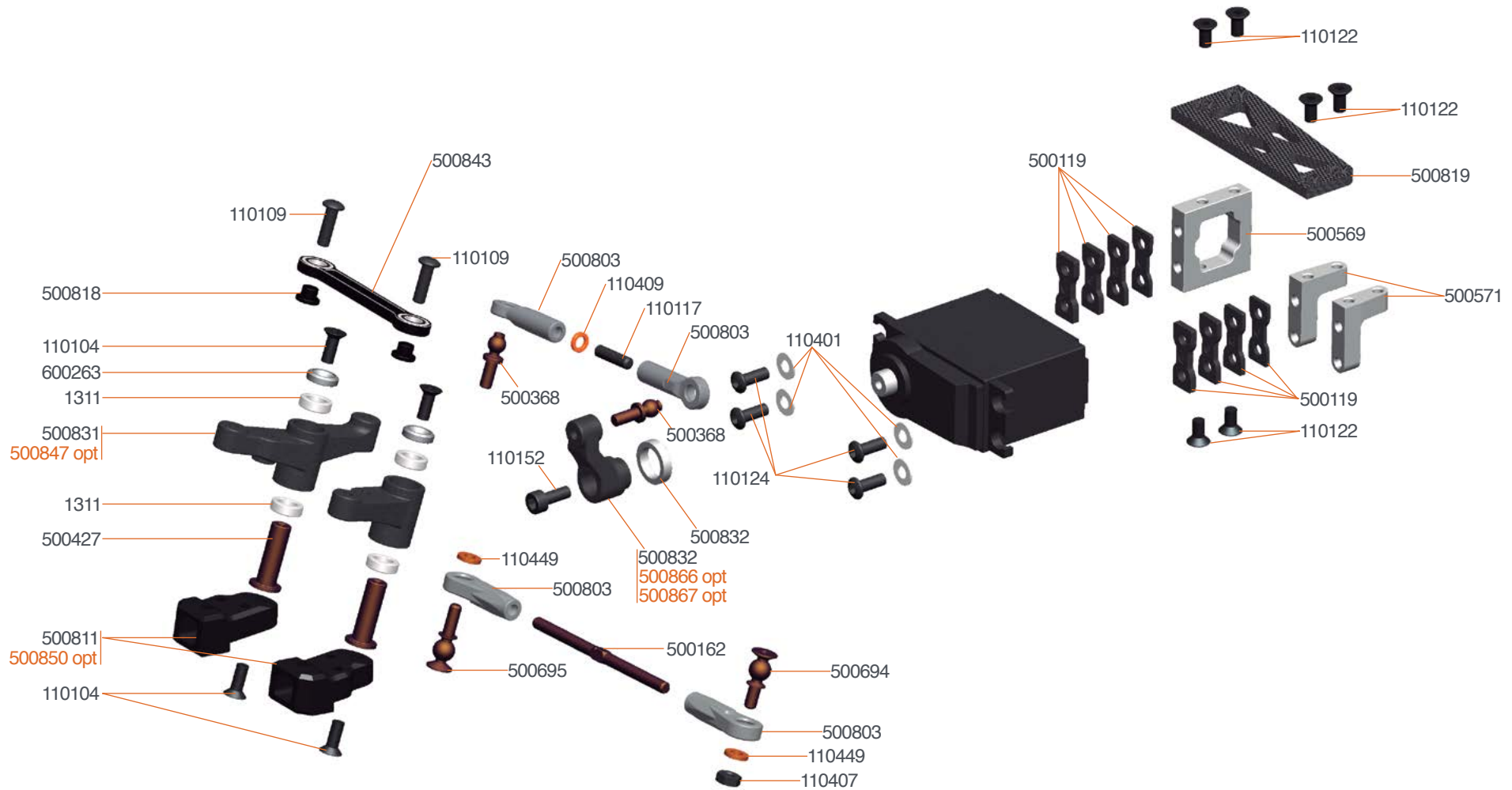

500847 Bellcrank L&R ALU SRX4 Gen3
 500850 Suspension bracket fr-rr L+R brass SRX4 Gen3
 500866 Servo lever 23T alu SRX4 Gen3

500867 Servo lever 25T alu SRX4 Gen3

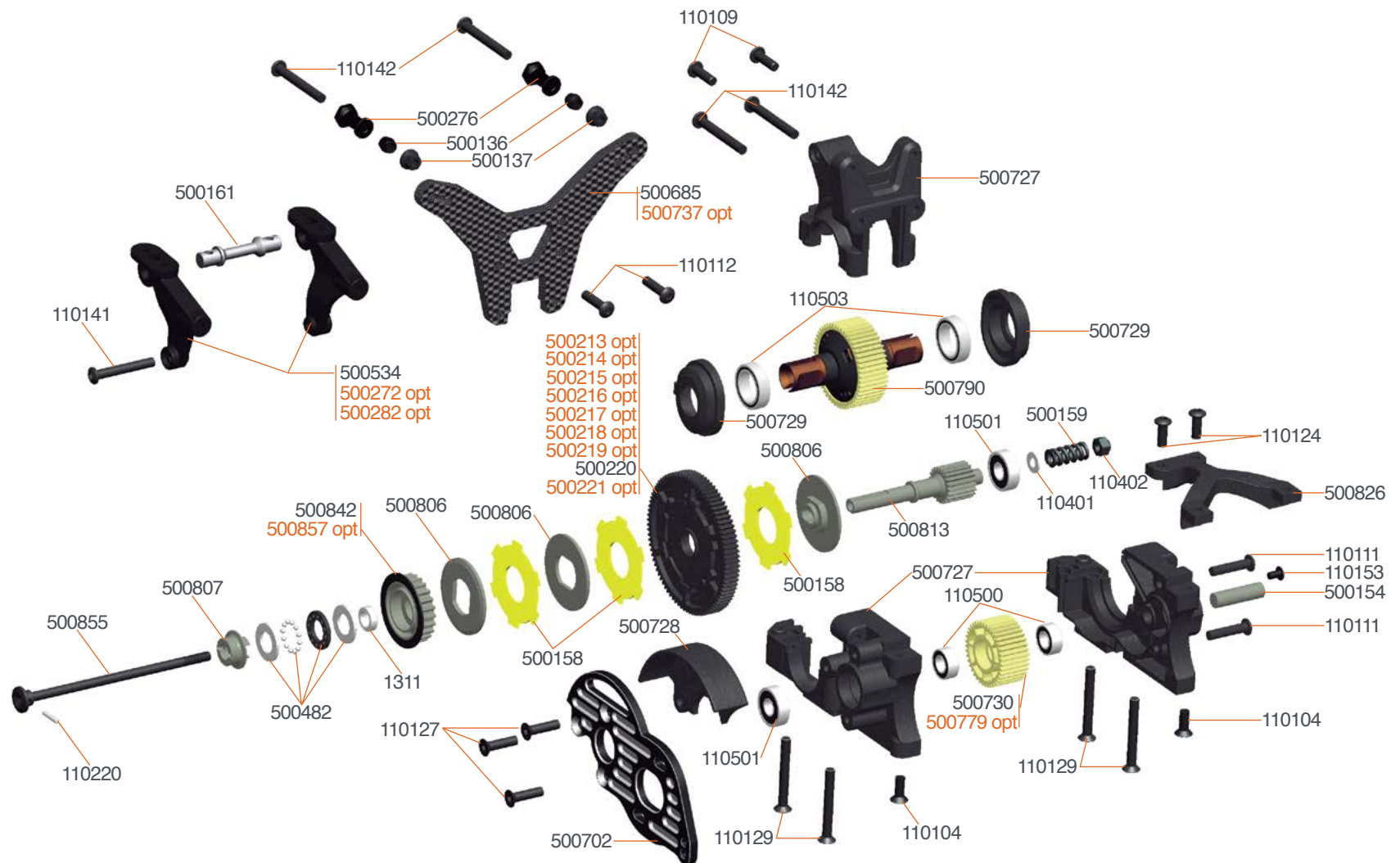

500213 Spur gear 70T SRX2
 500214 Spur gear 72T SRX2
 500215 Spur gear 76T SRX2
 500216 Spur gear 78T SRX2

500217 Spur gear 80T SRX2
 500218 Spur gear 82T SRX2
 500219 Spur gear 84T SRX2
 500221 Spur gear 88T SRX2

500272 Wingmount-set SRX2 MM
 500282 Wingmoung low SRX2 mm
 500737 Shocktower rr low carbon SRX2 Gen3
 500779 Idler gear 39T LF SRX2 Gen3

500856 Slipper Set 24T FT SRX4 Gen3
 500857 Slipper Pulley 24T FT SRX4 Gen3

FRONT SUSPENSION EXPLODED VIEW

SRX4
gen3

SERPENT



OPT

500443 Driveshaft FR 82mm (2) SRX4 Gen3
500822 Steering lever opt 0 (2) SRX4 Gen3
500824 Steering lever opt 2 (2) SRX4 Gen3
500850 Suspension bracket fr-rr L+R brass SRX4 Gen3

500858 DJC wheelaxle set fr 76mm (2) SRX4 Gen3
500859 DJC driveshaft fr 76mm (2) SRX4 Gen3
500860 DJC insert (2) SRX4 Gen3
500861 DJC spring clip (8) SRX4 Gen3

500862 DJC wheelaxle fr (2) SRX4 Gen 3
500863 DJC couplar (2) SRX4 Gen3
500451 Pivot pin fr outer TiN (2) SRX4
500543 Wishbone fr L+R SRX4 hard

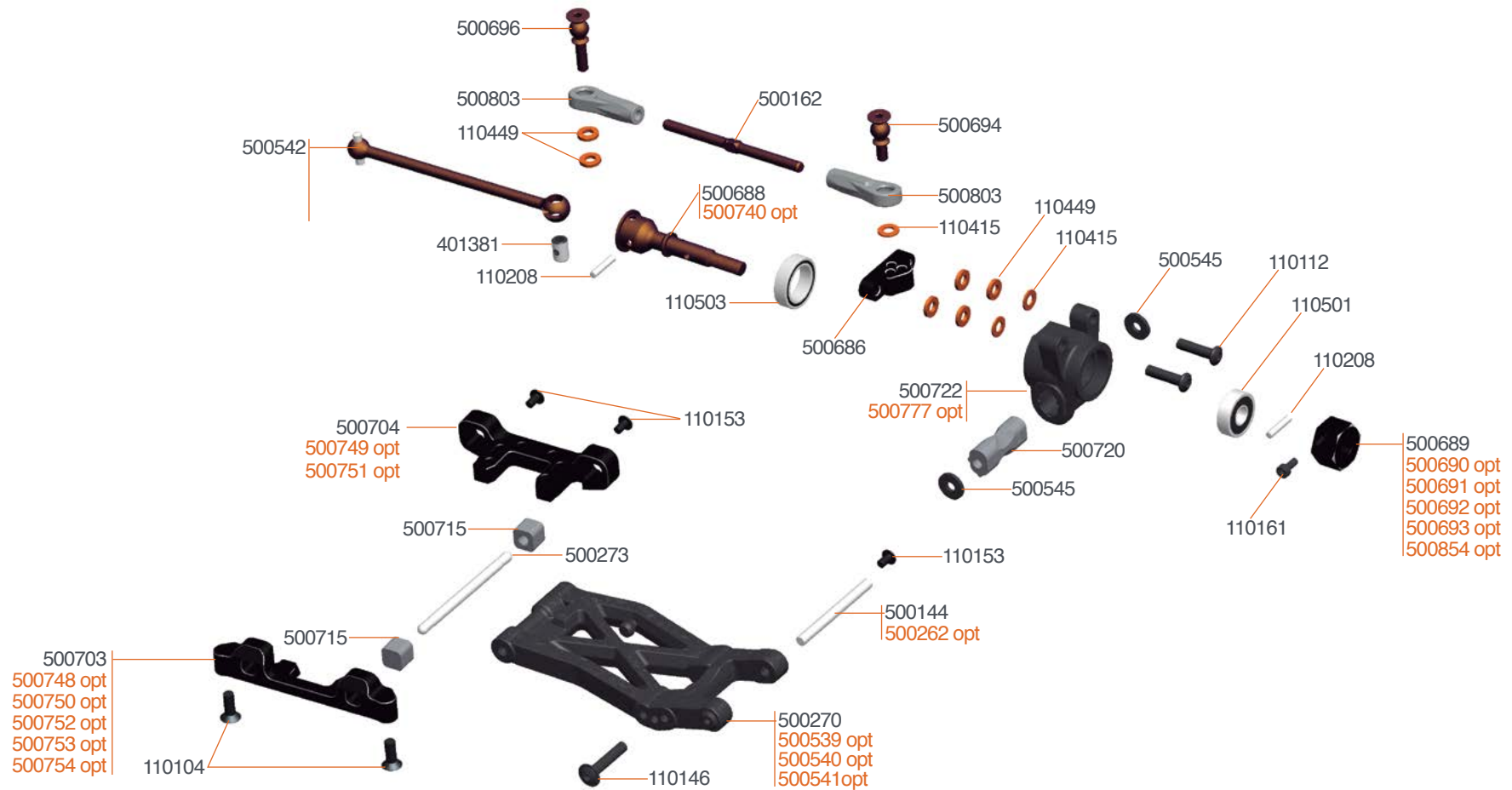

500262 Pivot pin fr inner / rr outer TiN coated (2) SRX2
500740 Wheelaxle short (2) SRX2 Gen 3
500748 Suspension bracket mid RR-FR SRX2 Gen3
500749 Suspension bracket mid RR-RR SRX2 Gen3
500750 Suspension bracket wide RR-FR SRX2 Gen3
500751 Suspension bracket wide RR-RR SRX2 Gen3
500752 Suspension bracket narrow RR-FR brass SRX2 Gen3

500753 Suspension bracket mid RR-FR brass SRX2 Gen3
500754 Suspension bracket wide RR-FR brass SRX2 Gen3
500784 Driveshaft rr 69mm SRX2 Gen3
500785 Driveshaft rr 68mm SRX2 Gen3
500190 Driveshaft rr 65mm (2) SRX2
500539 Wishbone rr L+R SRX2 MM V2 hard
500540 Wishbone rr L+R long SRX2 MM

500541 Wishbone rr L+R long SRX2 MM hard
500690 Wheelhexacon +2mm (2) SRX2 Gen3
500691 Wheelhexacon 0mm (2) SRX2 Gen3
500692 Wheelhexacon -1mm (2) SRX2 Gen3
500693 Wheelhexacon -2mm (2) SRX2 Gen3
500777 Short offset upright (2) SRX Gen3
500854 Wheelhexagon 0mm (2) SRX4 Gen3





OPT 500106 1/10 buggy rim rr yellow (2)
500189 Rear wing 6.5" SRX2
500252 Rear wing 7.0" SRX2

500375 Rear wing 7" (2) SRX
500492 Wing washer alu srx (2)
500622 1/10 buggy rim 4wd FR yellow SDX (2)

500734 Front bulkhead insert alu SRX2 Gen3
500868 Body lightweight SRX4 Gen3

TEAM SERPENT NETWORK

SPYDER SRX4 GEN3 SPARE PARTS www.serpent.com/500015/spares/



SPYDER SRX4 GEN3 OPTIONALS PARTS www.serpent.com/500015/Optionals/



SERPENT TOOLS www.serpent.com/product/Tools/



SERPENT MERCHANDISING www.serpent.com/product/Merchandising/



SERPENT WEBSITE AND BLOG

www.serpent.com
www.teamserpent.com
www.dragon-rc.com

SERPENT PROMO PAGES <http://promo.serpent.com>

SERPENT FACEBOOK GROUPS <http://promo.serpent.com/indexfb.htm>

SERPENT ADVANCED MANUALS <http://promo.serpent.com/sam/>

SERPENT SOCIAL MEDIA



www.facebook.com/SerpentMRC



www.youtube.com/user/SerpentMRC



www.twitter.com/SerpentMRC



www.plus.google.com/+SerpentModelcars/posts



www.weibo.com/teamserpent

SRX4

gen3



Manual SRX4 Gen3 # 89742-1

SERPENT
INNOVATIONS