

### Driver and Event

Name Tom Cockerill  
 Date 16th April 2011  
 Event Stotfold National  
 Weather Dry  
 Result TQ & Win

### Track Conditions

Surface Astro  
 Grip Level High  
 Track Condition



### Driver Notes

Ride Height: 22mm Front, 21mm Rear  
 Standard Length Chassis  
 Pistons: Rounded Front, Tapered Rear  
 1mm Bump Steer on Steering Block  
 Standard Rear Wing in Standard Position  
 RudeBits Under Lipo Weight  
 TrishBits Under Servo & Rear Weights

### Electrics and Gearing

E.S.C Speed Passion GT 2.0 Pro  
 Servo Savox  
 Receiver KO  
 Batteries Speed Power 5300 45C  
 Motor Speed Passion V3.0 8.5  
 Spur 78 Pinion 26

### Wheels and Tyres

Rear Wheels Schumacher RevLite  
 Rear Tyre Schumacher Yellow Minispike  
 Rear Insert Schumacher Tubby  
 Front Wheels Schumacher RevLite (Slim)  
 Front Tyre Schumacher Stagger Rib (U6592)  
 Front Insert N/A

Ext Gears 34/22   
 33/23   
 32/24

Differential Height  
 High  Low

Topdeck  
 Stiff  Medium  Soft

Rear Shocks  
 Oil 45 Spring 2.0  
 Ball Short   
 Socket Long

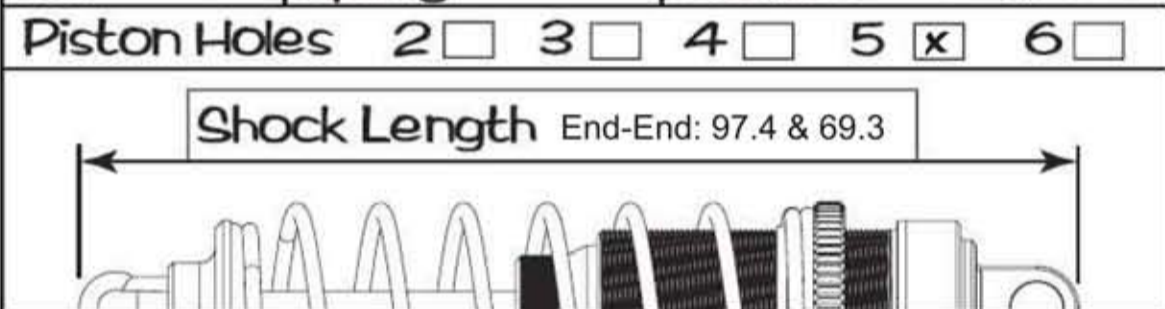

Front Shocks  
 Oil 60 Spring 4.0



### Rear Suspension

Anti roll bar No  1.20  1.40  1.60

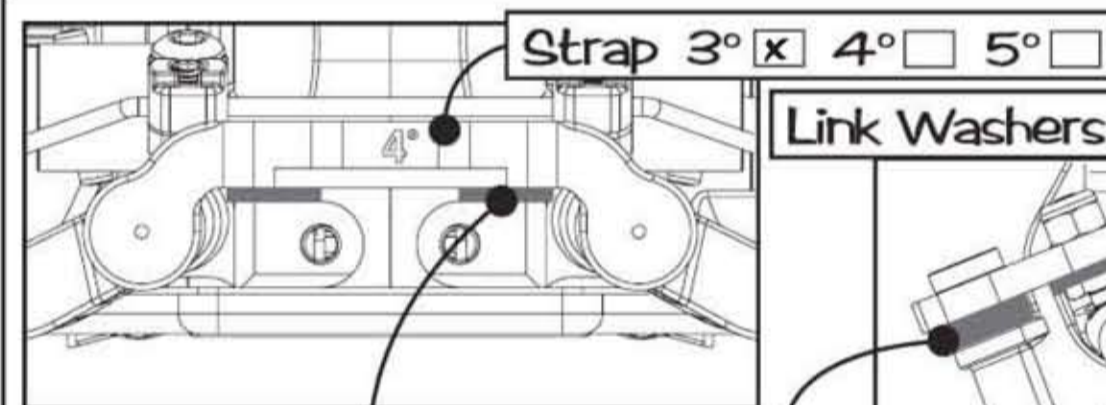

Antisquat Washers 2.5 mm Link Washers 1x Spacer mm

Shock Postion Front  Rear

Wheelbase Short  Med  Long

Rear Camber at Ride Height -1.0 deg

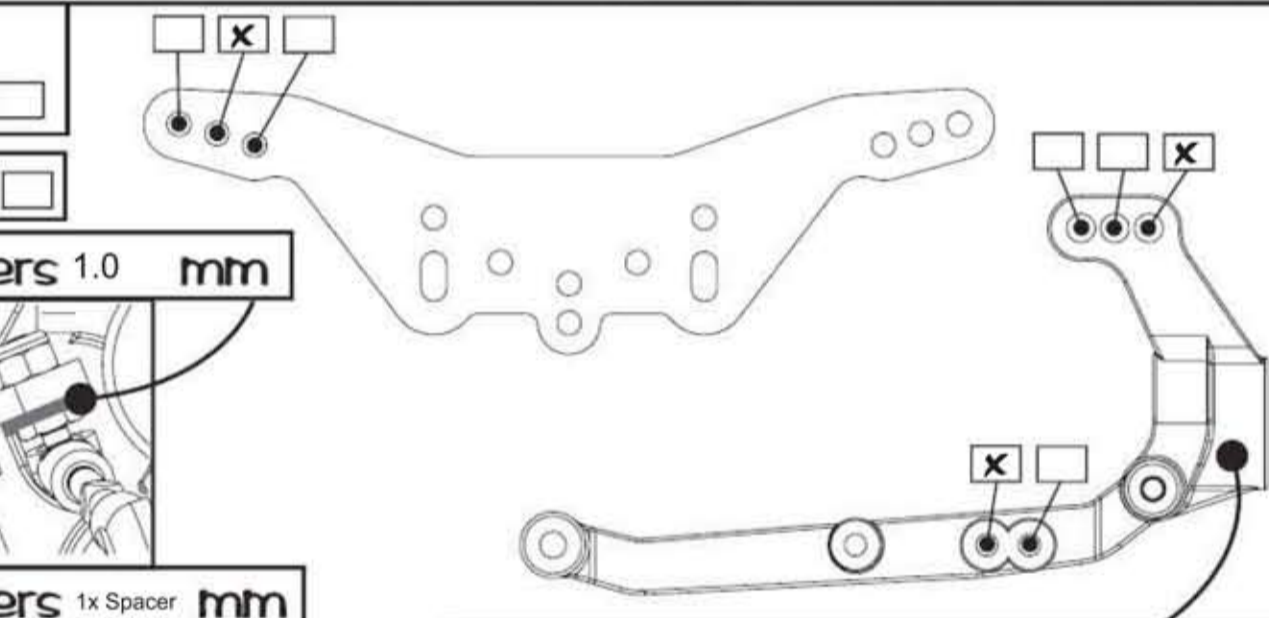

Rear Hub Carrier Alloy  Std

Alloy Hub Carrier +1°  -1°



### Front Suspension

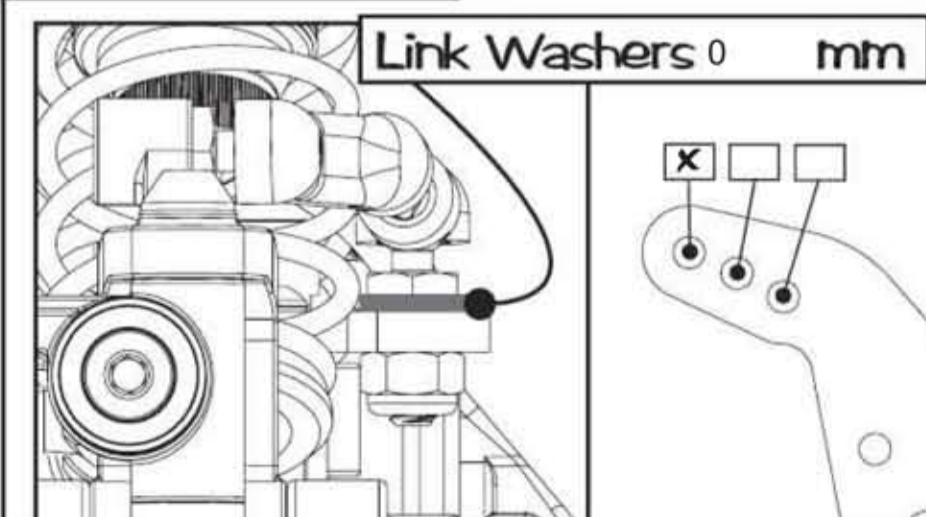

Front Camber at Ride Height -1.0 deg

Front Toe In 0 deg

