

Driver: Michal Orlowski Date: September 2024 Event/Track: EC 2024
Qualify: 1st Final: 1st Best Lap: 18.8

TRACK TYPE

Grip Level High Medium Low
 Type Tight Open Mixed
 Condition Flat Bumpy Mixed
 Surface Clay Long Astro Carpet
 Grass Short Astro Mixed
 Weather

TYRES

	FRONT	REAR
Tyres	Splinter	Cactus
Wheels	Schumacher	Schumacher
Inserts	-	Med

Notes:

Notes:

Jconcepts F2 body, 6.5in wing, Ti screws, Ti turnbuckles, & NMB bearings

FRONT SUSPENSION

Ride Height mm
 Wheelbase
 Toe deg In Out
 Camber at Ride Height deg
 Anti Roll Bar
 Front Wing Y N
 Bump Steer Washers mm
 Pivot Block Height H M L
 Steering Arm Kit A B C

Notes:

CF tower

KEY: P = Plastic, A = Alloy, B = Brass, CF = Carbon Fibre, S2 = Schumacher Composite, M = Medium, S = Stiff, Sh = Short, H = High, L = Low, F = Front, R = Rear, Y = Yes, N = No

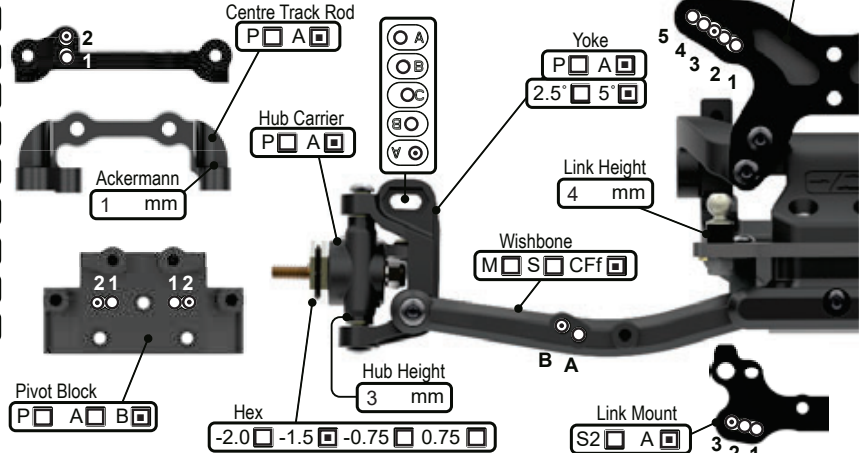

REAR SUSPENSION

Ride Height mm
 Wheelbase 0 +2 +4 +6
 Anti-Squat 1° 2° 3° 4°
 Toe 4° 3.5° 3° 2.5° 2° 1.5° 1.0° 0.5°
 Camber at Ride Height deg
 Anti Roll Bar 1.0 1.1 1.2 1.3 1.4
 Wing Gurney Height mm
 Rearward Shock Position Y N
 Driveshaft Type CVD U/J
 Gearbox Type Laydown Layback

Notes:

2nd inside hole on the tower

KEY: P = Plastic, A = Alloy, B = Brass, CF = Carbon Fibre, S2 = Schumacher Composite, M = Medium, S = Stiff, Sh = Short, H = High, L = Low, F = Front, R = Rear, Y = Yes, N = No

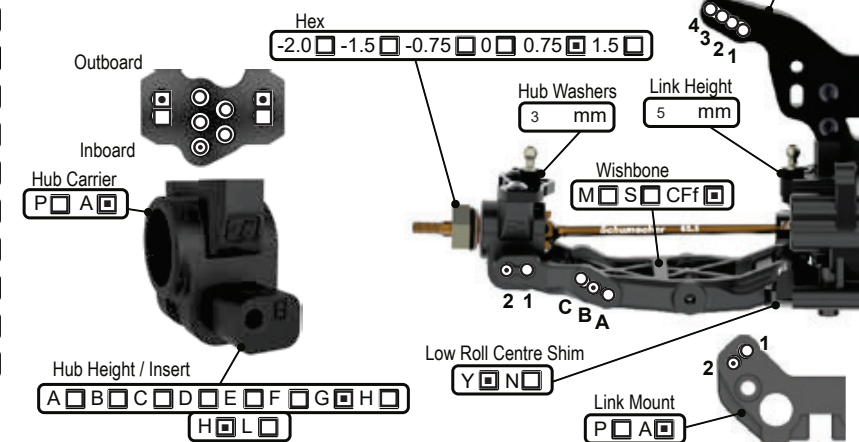

TRANSMISSION

B = Ball, 2g = 2 Gear, 4g = 4 Gear

Diff Height H M L
 Diff Oil cSt
 Diff Type B 2g 4g
 Motor
 Rotor Dia. mm
 Timing deg
 Pinion t
 Spur t
 Motor Plate A CF
 Lock Out Y N
 Slipper Plates 2 3

CHASSIS

Chassis A C/F
 Chassis Insert 0mm +5mm
 LiPo Position 1 2 3 4 5 6 7 8
 X Brace Y N
 Running Weight g
 Radio Tray 1 2 3

Notes:

EQUIPMENT

E.S.C. HW G2S
 Servo PowerHD GTS-3
 RX Sanwa RX-493i
 LiPo Sunpadow 4600
 Bodyshell JC F2

WEIGHTS

Chassis F R
 Rear Strap F R
 Radio Tray Y N
 Under LiPo Y N

SHOCKS

KEY: i = Internal, e = External, V = Vented, S = Sealed, A = Aeration

	FRONT	REAR
Cap	<input type="checkbox"/> V <input type="checkbox"/> S <input type="checkbox"/> A <input type="checkbox"/>	<input type="checkbox"/> V <input type="checkbox"/> S <input type="checkbox"/> A <input type="checkbox"/>
Body	kashima	kashima
Oil	525 cSt	400 cSt
Piston	2x1.7	2x1.9
Spring	orange hr lb/in	black hr lb/in
Limiters (i)	<input type="text" value=""/> mm	<input type="text" value=""/> mm
Stroke	22.5 mm	27.8 mm
Limiters (e)	3 mm	2 mm

Notes:

Aeration F&R

