



Driver: Michal Orlowski

Date: February 2024

Event/Track: EOS rd2 Daun, Germany

Qualify: 1st

Final: 1st

Best Lap: 18.2

### TRACK TYPE

Grip Level  High  Medium  Low

Type  Tight  Open  Mixed

Condition  Flat  Bumpy  Mixed

Surface  Clay  Long Astro  Carpet   
 Grass  Short Astro  Mixed

Weather

### TYRES

	FRONT	REAR
Tyres	EOS Schumacher	EOS Schumacher
Wheels	EOS Schumacher	EOS Schumacher
Inserts	-	EOS Schumacher

Notes:

### Notes:

Jconcepts F2 body, 6.5in wing, Ti screws, Ti turnbuckles, NMB bearings

MR33 motor fan

### FRONT SUSPENSION

Ride Height  mm

Wheelbase   +1.5  +3.0  +4.5

Toe  deg  In  Out

Camber at Ride Height  deg

Anti Roll Bar   1.0  1.1  1.2

Front Wing  Y  N

Bump Steer Washers  mm

Pivot Block Height  H  M  L

Steering Arm  Kit  A  B  C

Notes:

CF tower

KEY: P = Plastic, A = Alloy, B = Brass, CF = Carbon Fibre, S2 = Schumacher Composite, M = Medium, S = Stiff, Sh = Short, H = High, L = Low, F = Front, R = Rear, Y = Yes, N = No

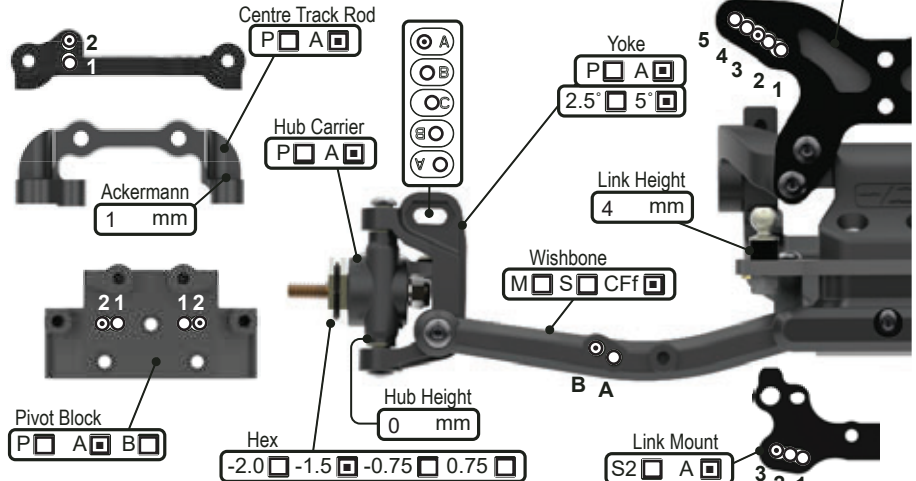

### REAR SUSPENSION

Ride Height  mm

Wheelbase  0  +2  +4  +6

Anti-Squat  1°  2°  3°  4°

Toe  4°  3.5°  3°  2.5°  2°  1.5°  1.0°  0.5°

Camber at Ride Height  deg

Anti Roll Bar  1.0  1.1  1.2  1.3  1.4

Wing Gurney Height  mm

Rearward Shock Position  Y  N

Driveshaft Type  CVD  U/J

Gearbox Type  Laydown  Layback

Notes: inside hole on the tower

KEY: P = Plastic, A = Alloy, B = Brass, CF = Carbon Fibre, S2 = Schumacher Composite, M = Medium, S = Stiff, Sh = Short, H = High, L = Low, F = Front, R = Rear, Y = Yes, N = No

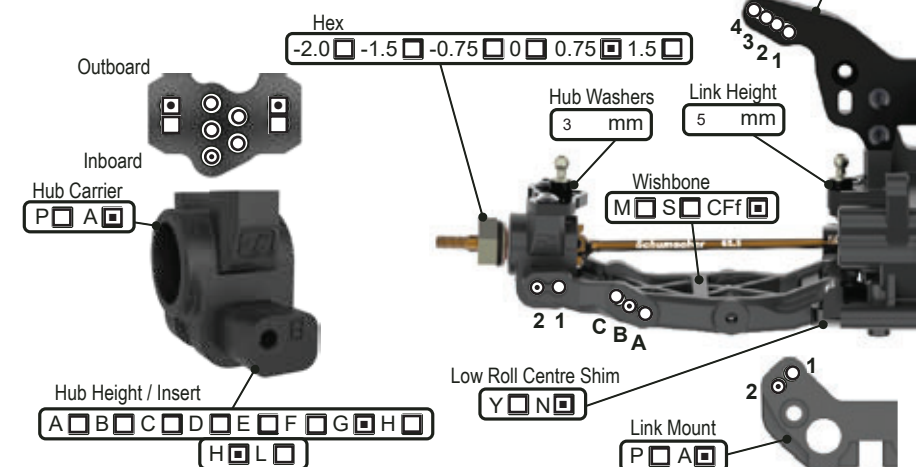

### TRANSMISSION

B = Ball, 2g = 2 Gear, 4g = 4 Gear

Diff Height  H  M  L

Diff Oil  cSt

Diff Type  B  2g  4g

Motor

Rotor Dia.  mm

Timing  deg

Pinion  t

Spur  t

Motor Plate  A  CF

Lock Out  Y  N

Slipper Plates  2  3

### CHASSIS

Chassis  A  C/F

Chassis Insert  0mm  +5mm

LiPo Position  1  2  3  4  5  6  7  8

X Brace  Y  N

Running Weight  g

Radio Tray  1  2  3

Notes:

### EQUIPMENT

E.S.C.

Servo

RX

LiPo

Bodyshell

### WEIGHTS

Chassis  F  R

Rear Strap  F  R

Radio Tray  Y  N

Under LiPo  Y  N

### SHOCKS

KEY: i = Internal, e = External, V = Vented, S = Sealed, A = Aeration

	FRONT	REAR
Cap	<input type="checkbox"/> V <input type="checkbox"/> S <input type="checkbox"/> A <input type="checkbox"/>	<input type="checkbox"/> V <input type="checkbox"/> S <input type="checkbox"/> A <input type="checkbox"/>
Body	kashima	kashima
Oil	575 cSt	525 cSt
Piston	3x1.5	3x1.6
Spring	black hr lb/in	black hr lb/in
Limiters (i)	2 mm	mm
Stroke	20.5 mm	27.8 mm
Limiters (e)	mm	mm

Notes:

Aeration F&R

