

Driver: _____ Date: _____ Event/Track: _____
 Qualify: _____ Final: _____ Best Lap: _____

TRACK TYPE

Grip Level High Medium Low
 Type Tight Open Mixed
 Condition Flat Bumpy
 Surface Clay Astroturf Carpet
 Grass _____
 Weather _____

TYRES

| | FRONT | REAR |
|---------|-------|------|
| Tyres | | |
| Wheels | | |
| Inserts | | |
| Notes: | | |

Notes:

FRONT SUSPENSION

KEY: P = Plastic, A = Alloy, B = Brass, CF = Carbon Fibre, S2 = Schumacher Composite, M = Medium, S = Stiff, Sh = Short, H = High, L = Low, F = Front, R = Rear, Y = Yes, N = No

Ride Height _____ mm
 Wheelbase 0 +1.5 +3.0 +4.5
 Toe _____ deg In Out
 Camber at Ride Height _____ deg
 Anti Roll Bar 0.9 1.0 1.1 1.2
 Front Wing Y N
 Bump Steer Washers _____ mm
 Pivot Block Height H M L
 Steering Arm Kit A B C

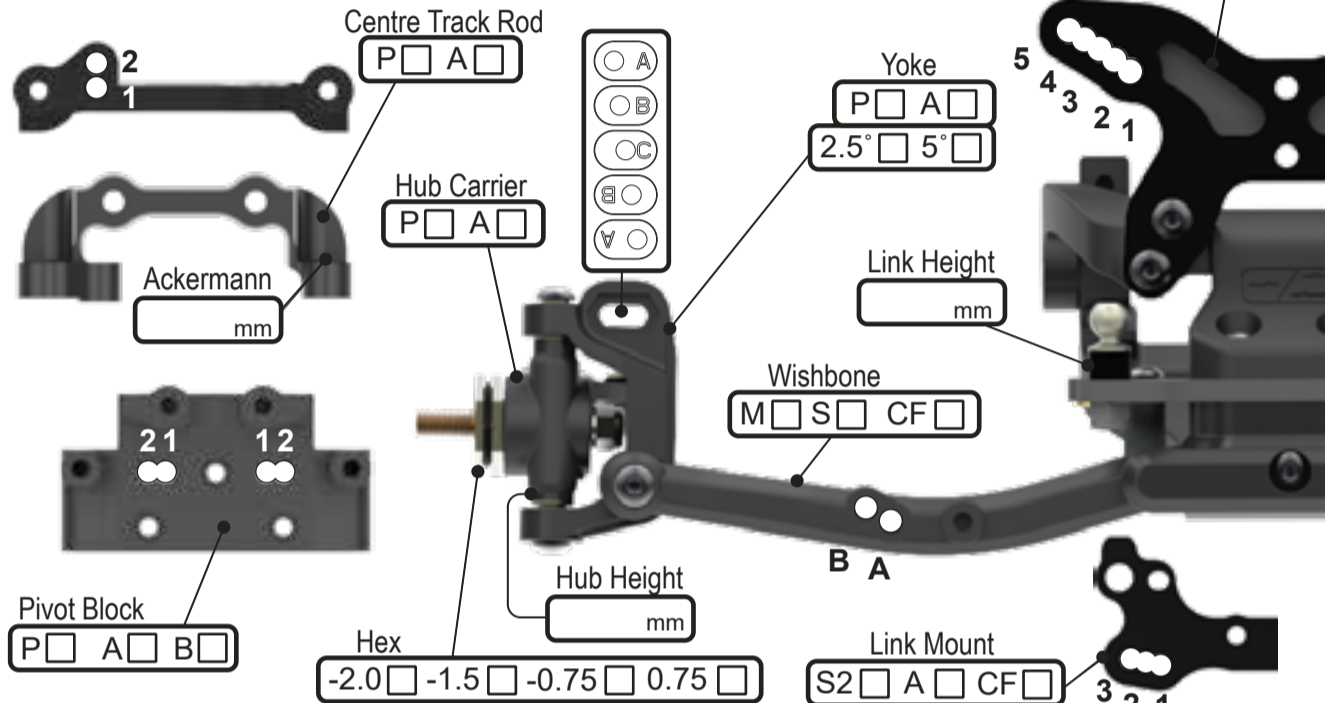

Notes:

REAR SUSPENSION

KEY: P = Plastic, A = Alloy, B = Brass, CF = Carbon Fibre, S2 = Schumacher Composite, M = Medium, S = Stiff, Sh = Short, H = High, L = Low, F = Front, R = Rear, Y = Yes, N = No

Ride Height _____ mm
 Wheelbase 0 +2 +4 +6
 Anti-Squat 1° 2° 3° 4°
 Toe 4° 3.5° 3° 2.5° 2° 1.5° 1.0° 0.5°
 Camber at Ride Height _____ deg
 Anti Roll Bar 1.0 1.1 1.2 1.3 1.4
 Wing Gurney Height _____ mm
 Rearward Shock Position Y N
 Driveshaft Type CVD U/J
 Gearbox Type Laydown Layback

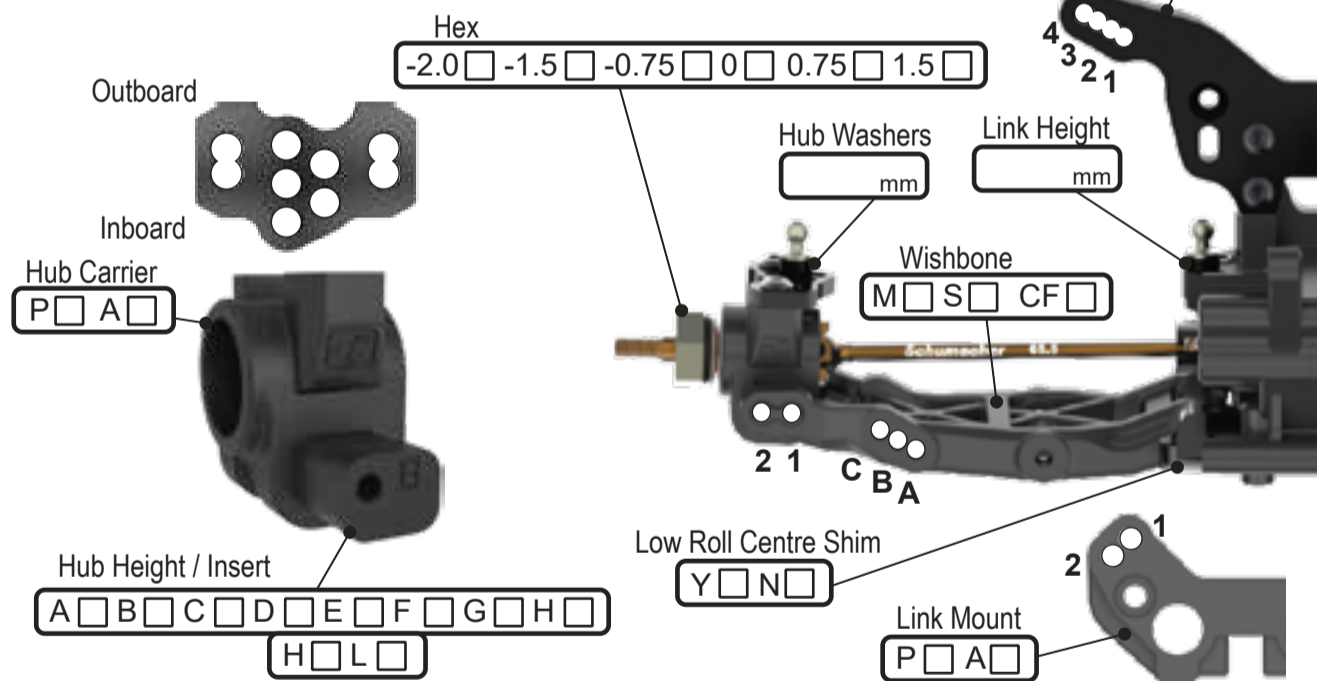

Notes:

TRANSMISSION

B = Ball, 2g = 2 Gear, 4g = 4 Gear

Diff Height H M L
 Diff Oil _____ cSt
 Diff Type B 2g 4g
 Motor _____
 Rotor Dia. _____ mm
 Timing _____ deg
 Pinion _____ t
 Spur _____ t
 Motor Plate A CF
 Lock Out Y N
 Slipper Plates 2 3

CHASSIS

Chassis A C/F
 Chassis Insert 0mm +5mm
 LiPo Position 1 2 3 4 5 6 7 8
 X Brace Y N
 Running Weight _____ g
 Radio Tray 1 2 3

Notes:

EQUIPMENT

E.S.C. _____
 Servo _____
 Receiver _____
 Battery _____
 Bodyshell _____

WEIGHTS

Chassis F R
 Rear Strap F R
 Radio Tray Y N
 Under LiPo Y N

SHOCKS

KEY: i = Internal, e = External, V = Vented, S = Sealed, A = Aeration

| | FRONT | REAR |
|--------------|--|--|
| Cap | V <input type="checkbox"/> S <input type="checkbox"/> A <input type="checkbox"/> | V <input type="checkbox"/> S <input type="checkbox"/> A <input type="checkbox"/> |
| Body | | |
| Oil | _____ cSt | _____ cSt |
| Piston | | |
| Spring | _____ lb/in | _____ lb/in |
| Limiters (i) | _____ mm | _____ mm |
| Stroke | _____ mm | _____ mm |
| Limiters (e) | _____ mm | _____ mm |

Notes:

