

Driver: Daniel Kobbevik Date: Jan Event/Track: EOS Daun
Qualify: 4th Final: 3rd Best Lap:

TRACK TYPE

Grip Level High Medium Low
 Type Tight Open Mixed
 Condition Flat Bumpy Mixed
 Surface Clay Long Astro Carpet
 Grass Short Astro Mixed
 Weather Indoor/warm hall

TYRES

	FRONT	REAR
Tyres	Splinter	Cactus
Wheels	Schumacher	Schumacher
Inserts	none	U6734

Notes:
Glue front wall

Notes:

E-H inserts and LD3D UJ's (U8629) & (U8606)
 schumacher pro bearings
 1up racing titanium screws
 1up racing turnbuckles
 MR33 30mm fan

FRONT SUSPENSION

KEY: P = Plastic, A = Alloy, B = Brass, CF = Carbon Fibre, S2 = Schumacher Composite, M = Medium, S = Stiff, Sh = Short, H = High, L = Low, F = Front, R = Rear, Y = Yes, N = No

Ride Height mm
 Wheelbase 0 +1.5 +3.0 +4.5
 Toe deg In Out
 Camber at Ride Height deg
 Anti Roll Bar 0.9 1.0 1.1 1.2
 Front Wing Y N
 Bump Steer Washers mm
 Pivot Block Height H M L
 Steering Arm Kit A B C

Notes:

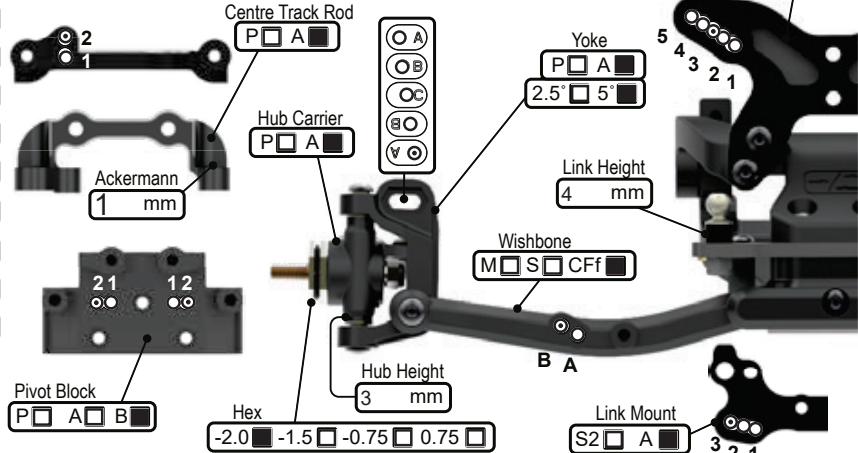

REAR SUSPENSION

KEY: P = Plastic, A = Alloy, B = Brass, CF = Carbon Fibre, S2 = Schumacher Composite, M = Medium, S = Stiff, Sh = Short, H = High, L = Low, F = Front, R = Rear, Y = Yes, N = No

Ride Height mm
 Wheelbase 0 +2 +4 +6
 Anti-Squat 1 2 3 4
 Toe 4 3.5 3 2.5 2 1.5 1 0.5
 Camber at Ride Height deg
 Anti Roll Bar 1.0 1.1 1.2 1.3 1.4
 Wing Gurney Height mm
 Rearward Shock Position Y N
 Driveshaft Type CVD U/J
 Gearbox Type Laydown Layback

Notes:

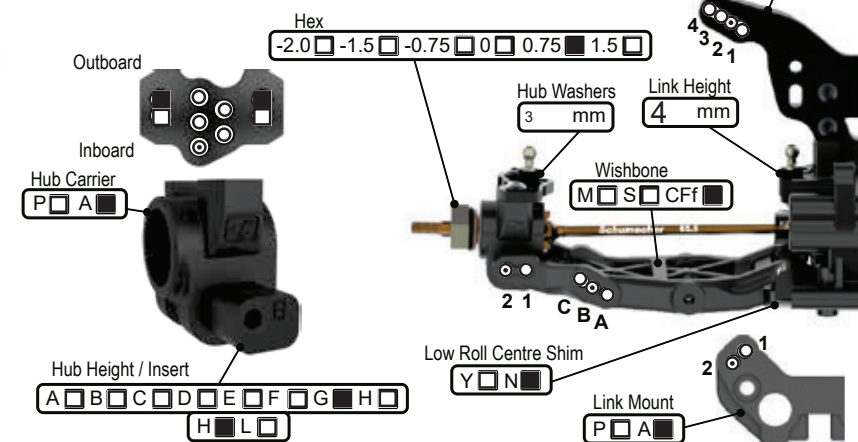

TRANSMISSION

B = Ball, 2g = 2 Gear, 4g = 4 Gear

Diff Height H M L
 Diff Oil cSt
 Diff Type B 2g 4g
 Motor
 Rotor Dia. mm
 Timing deg
 Pinion t
 Spur t
 Motor Plate A CF
 Lock Out Y N
 Slipper Plates 2 3

CHASSIS

Chassis A C/F
 Chassis Insert 0mm +5mm
 LiPo Position 1 2 3 4 5 6 7 8
 X Brace Y N
 Running Weight g
 Radio Tray 1 2 3

Notes:

EQUIPMENT

E.S.C.
 Servo
 RX
 LiPo
 Bodyshell

WEIGHTS

Chassis F R
 Rear Strap F R
 Radio Tray Y N
 Under LiPo Y N

SHOCKS

KEY: i = Internal, e = External, V = Vented, S = Sealed, A = Aeration

	FRONT	REAR
Cap	<input type="checkbox"/> V <input type="checkbox"/> S <input type="checkbox"/> A <input type="checkbox"/>	<input type="checkbox"/> V <input type="checkbox"/> S <input type="checkbox"/> A <input type="checkbox"/>
Body	Kashima	Kashima
Oil	550 cSt	500 cSt
Piston	2x1.7	2x1.9
Spring	Orange HR lb/in	Black HR lb/in
Limiters (i)	2 mm	0 mm
Stroke	20.5 mm	28 mm
Limiters (e)	3 mm	2 mm

Notes:

3mm stand-off

