

Driver: Broc Champlin

Date: 10-11-23

Event/Track: Worlds @ Hobby Action

Quality: 4th

Final: 3rd

Best Lap: n/a

TRACK TYPE

Grip Level High Medium Low

Type Tight Open Mixed

Condition Flat Bumpy Mixed

Surface Clay Long Astro Carpet
 Grass Short Astro Mixed

Weather 75 F / Fair

TYRES

	FRONT	REAR
Tyres	AKA Spec	AKA Spec
Wheels	Jconcepts	Jconcepts
Inserts	spec	spec

Notes:

Notes:

Whitz Racing Products:
 HyperGlide Ceramic Bearings
 HyperMax 3.5mm Ti Turnbuckles
 HyperLite Ti Screws

FRONT SUSPENSION

Ride Height 19 mm

Wheelbase 0 +1.5 +3.0 +4.5

Toe 1 deg In Out

Camber at Ride Height -1 deg

Anti Roll Bar 0.9 1.0 1.1 1.2

Front Wing Y N

Bump Steer Washers 1.5 mm

Pivot Block Height H M L

Steering Arm Kit A B C

Notes:

KEY: P = Plastic, A = Alloy, B = Brass, CF = Carbon Fibre, S2 = Schumacher Composite, M = Medium, S = Stiff, Sh = Short, H = High, L = Low, F = Front, R = Rear, Y = Yes, N = No

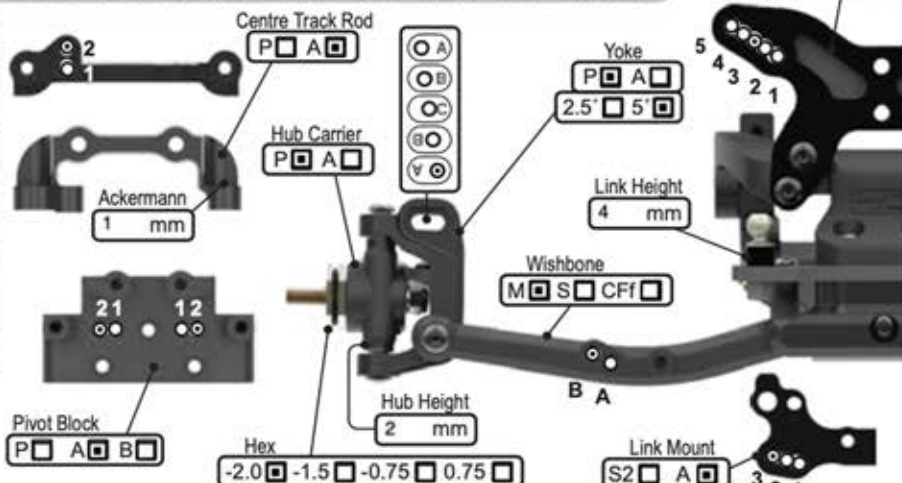

REAR SUSPENSION

Ride Height 19 mm

Wheelbase 0 +2 +4 +6

Anti-Squat 1° 2° 3° 4°

Toe 4° 3.5° 3° 2.5° 2° 1.5° 1.0° 0.5°

Camber at Ride Height -1.5 deg

Anti Roll Bar 1.0 1.1 1.2 1.3 1.4

Wing Gurney Height n/a mm

Rearward Shock Position Y N

Driveshaft Type CVD U/J

Gearbox Type Laydown Layback

Notes:

KEY: P = Plastic, A = Alloy, B = Brass, CF = Carbon Fibre, S2 = Schumacher Composite, M = Medium, S = Stiff, Sh = Short, H = High, L = Low, F = Front, R = Rear, Y = Yes, N = No

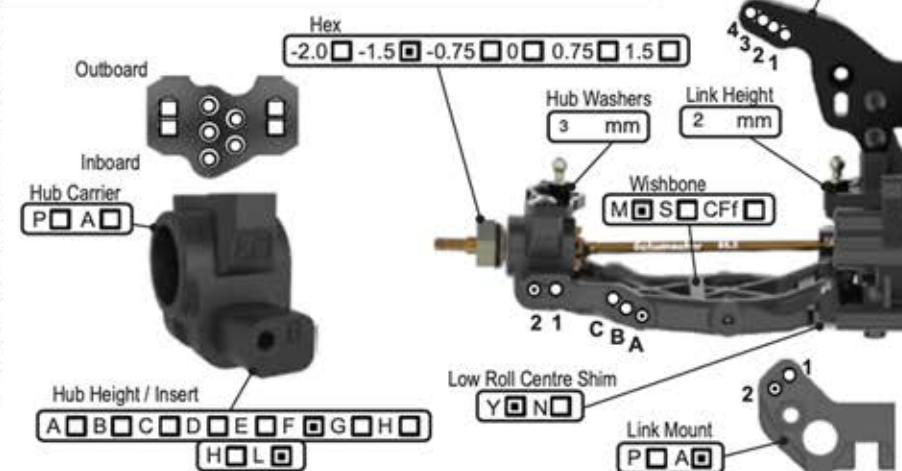

TRANSMISSION

B = Ball, 2g = 2 Gear, 4g = 4 Gear

Diff Height H M L

Diff Oil cSt

Diff Type B 2g 4g

Motor LRP 7.0

Rotor Dia. 12.1 mm

Timing -5 deg

Pinion 21 t

Spur 78 t

Motor Plate A CF

Lock Out Y N

Slipper Plates 2 3

CHASSIS

Chassis A C/F

Chassis Insert 0mm +5mm

LiPo Position
 1 2 3 4 5 6 7 8

X Brace Y N

Running Weight 1525 g

Radio Tray 1 2 3

Notes:

EQUIPMENT

E.S.C. LRP Flow X

Servo MKS HBL 599 SL

RX

LiPo LRP 4200 mAh

Bodyshell Jconcepts P2

WEIGHTS

Chassis F R

Rear Strap F R

Radio Tray Y N

Under LiPo Y N

SHOCKS

KEY: i = Internal, e = External, V = Vented, S = Sealed, A = Aeration

	FRONT	REAR
Cap	<input type="checkbox"/> V <input type="checkbox"/> S <input type="checkbox"/> A <input type="checkbox"/>	<input type="checkbox"/> V <input type="checkbox"/> S <input type="checkbox"/> A <input type="checkbox"/>
Body	Kashima Coat	Kashima Coat
Oil	32.5 AE cSt	30 AE cSt
Piston	2 hole 1.8	2 hole 1.9
Spring	AE Blue 13 lb/in	AEv2 Grey lb/in
Limiters (i)	0 mm	0 mm
Stroke	22.5 mm	28.5 mm
Limiters (e)	2 mm	0 mm

Notes: