

Driver: Ben Smith Date: 18/05/24 Event/Track: BRCA National RD2 @ Herts
Qualify: P1 Final: P1 Best Lap:

TRACK TYPE

Grip Level High Medium Low
 Type Tight Open Mixed
 Condition Flat Bumpy Mixed
 Surface Clay Long Astro Carpet
 Grass Short Astro Mixed
 Weather

TYRES

	FRONT	REAR
Tyres	Fusion Slims	Mezzo
Wheels	Kit	Kit
Inserts	N/A	Mediums

Notes:
Fusion slim glued down to the rim with glue on the sidewall

Notes:
VRP Pistons used

FRONT SUSPENSION

Ride Height mm
 Wheelbase
 Toe deg In Out
 Camber at Ride Height deg
 Anti Roll Bar
 Front Wing Y N
 Bump Steer Washers mm
 Pivot Block Height H M L
 Steering Arm Kit A B C

Notes:

KEY: P = Plastic, A = Alloy, B = Brass, CF = Carbon Fibre, S2 = Schumacher Composite, M = Medium, S = Stiff, Sh = Short, H = High, L = Low, F = Front, R = Rear, Y = Yes, N = No

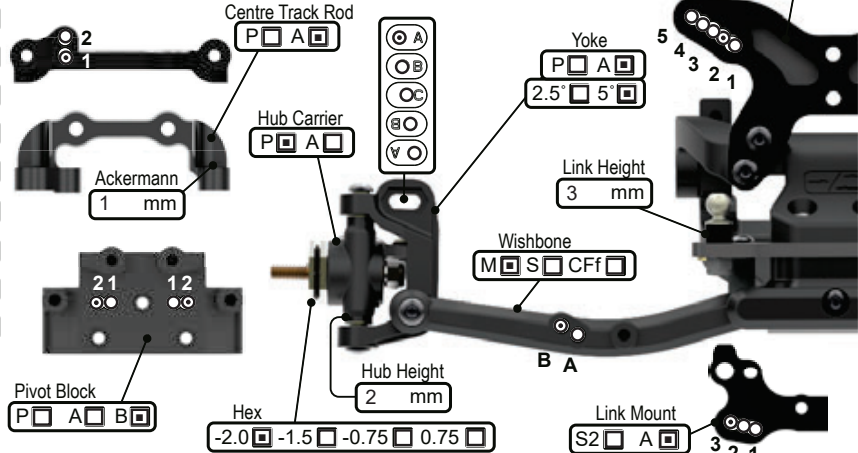

REAR SUSPENSION

Ride Height mm
 Wheelbase 0 +2 +4 +6
 Anti-Squat 1° 2° 3° 4°
 Toe 4° 3.5° 3° 2.5° 2° 1.5° 1.0° 0.5°
 Camber at Ride Height deg
 Anti Roll Bar
 Wing Gurney Height mm
 Rearward Shock Position Y N
 Driveshaft Type CVD U/J
 Gearbox Type Laydown Layback

Notes:

KEY: P = Plastic, A = Alloy, B = Brass, CF = Carbon Fibre, S2 = Schumacher Composite, M = Medium, S = Stiff, Sh = Short, H = High, L = Low, F = Front, R = Rear, Y = Yes, N = No

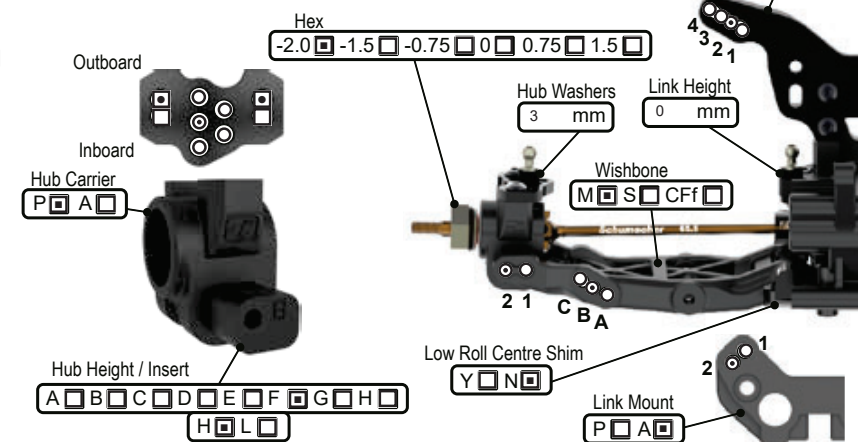

TRANSMISSION

B = Ball, 2g = 2 Gear, 4g = 4 Gear

Diff Height H M L
 Diff Oil cSt
 Diff Type B 2g 4g
 Motor H/W 6.0t
 Rotor Dia. mm
 Timing deg
 Pinion t
 Spur t
 Motor Plate A CF
 Lock Out Y N
 Slipper Plates 2 3

CHASSIS

Chassis A C/F
 Chassis Insert mm +5mm
 LiPo Position 1 2 3 4 5 6 7 8
 X Brace Y N
 Running Weight g
 Radio Tray 1 2 3
Notes:

EQUIPMENT

E.S.C. H/W
 Servo Aerox MP1
 RX Sanwa
 LiPo Intellect 4800
 Bodyshell Jc S2

WEIGHTS

Chassis F R
 Rear Strap F R
 Radio Tray Y N
 Under LiPo Y N

SHOCKS

KEY: i = Internal, e = External, V = Vented, S = Sealed, A = Aeration

	FRONT	REAR
Cap	<input type="checkbox"/> V <input type="checkbox"/> S <input type="checkbox"/> A <input type="checkbox"/>	<input type="checkbox"/> V <input type="checkbox"/> S <input type="checkbox"/> A <input type="checkbox"/>
Body	Kashima	Kashima
Oil	500 cSt	400 cSt
Piston	2 x 1.7	2 x 1.9
Spring	ae orange lb/in	ae yellow lb/in
Limiters (i)	0 mm	0 mm
Stroke	23 mm	29 mm
Limiters (e)	0 mm	0 mm

Notes:

