

Driver: Ben Smith Date: 28/10/24 Event/Track: Base Indoor Setup

Qualify: Final: Best Lap:

TRACK TYPE

Grip Level High Medium Low

Type Tight Open Mixed

Condition Flat Bumpy Mixed

Surface Clay Long Astro Carpet
 Grass Short Astro Mixed

Weather

TYRES

	FRONT	REAR
Tyres	Splinter	Cactus
Wheels	Schuey	Schuey
Inserts	N/A	Mediums

Notes:
Glue outer sidewall on fronts up to the webbing

Notes:

If you can't get VRP pistons, use red flat pistons with same holes and oils.

FRONT SUSPENSION

Ride Height mm

Wheelbase

Toe deg In Out

Camber at Ride Height deg

Anti Roll Bar

Front Wing Y N

Bump Steer Washers mm

Pivot Block Height H M L

Steering Arm Kit A B C

Notes:
V2 Brass Pivot Block

KEY: P = Plastic, A = Alloy, B = Brass, CF = Carbon Fibre, S2 = Schumacher Composite, M = Medium, S = Stiff, Sh = Short, H = High, L = Low, F = Front, R = Rear, Y = Yes, N = No

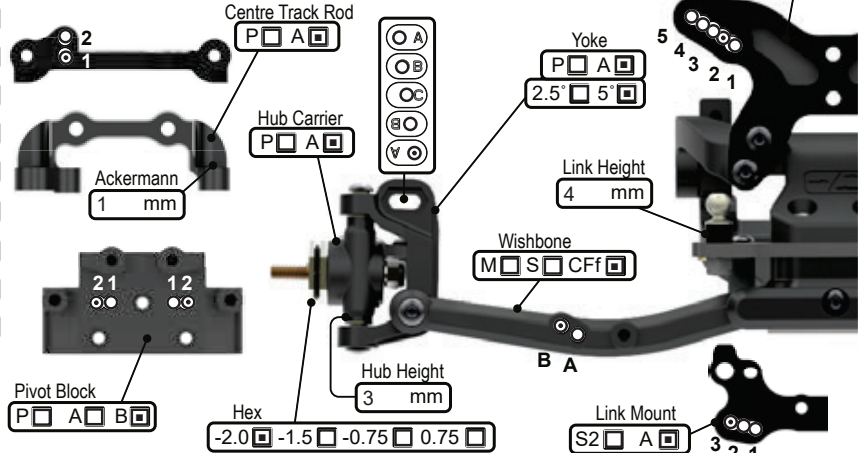

REAR SUSPENSION

Ride Height mm

Wheelbase 0 +2 +4 +6

Anti-Squat 1° 2° 3° 4°

Toe 4° 3.5° 3° 2.5° 2° 1.5° 1.0° 0.5°

Camber at Ride Height deg

Anti Roll Bar 1.0 1.1 1.2 1.3 1.4

Wing Gurney Height mm

Rearward Shock Position Y N

Driveshaft Type CVD U/J

Gearbox Type Laydown Layback

Notes:
Dirt U/J
Dirt Hub
Rear hinge pin high

KEY: P = Plastic, A = Alloy, B = Brass, CF = Carbon Fibre, S2 = Schumacher Composite, M = Medium, S = Stiff, Sh = Short, H = High, L = Low, F = Front, R = Rear, Y = Yes, N = No

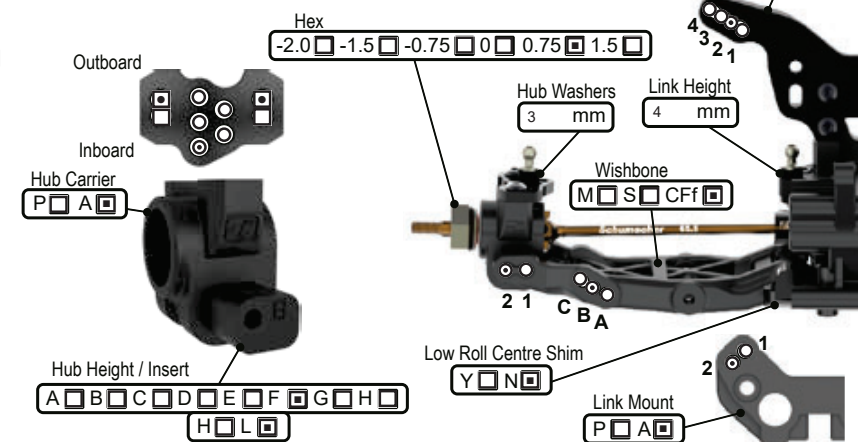

TRANSMISSION

B = Ball, 2g = 2 Gear, 4g = 4 Gear

Diff Height H M L

Diff Oil cSt

Diff Type B 2g 4g

Motor

Rotor Dia. mm

Timing deg

Pinion t

Spur t

Motor Plate A CF

Lock Out Y N

Slipper Plates 2 3

CHASSIS

Chassis A C/F

Chassis Insert 0mm +5mm

LiPo Position 1 2 3 4 5 6 7 8

X Brace Y N

Running Weight g

Radio Tray 1 2 3

Notes:

EQUIPMENT

E.S.C. H/W G3

Servo Aerox MP1

RX Sanwa

LiPo Intellect 4800

Bodyshell Jc S2

WEIGHTS

Chassis F R

Rear Strap F R

Radio Tray Y N

Under LiPo Y N

SHOCKS

KEY: i = Internal, e = External, V = Vented, S = Sealed, A = Aeration

	FRONT	REAR
Cap	<input type="checkbox"/> V <input type="checkbox"/> S <input type="checkbox"/> A	<input type="checkbox"/> V <input type="checkbox"/> S <input type="checkbox"/> A
Body	Kashima	Kashima
Oil	600 cSt	450 cSt
Piston	VRP 2 x 1.7	VRP 2 x 1.9
Spring	Orange HR lb/in	Black HR lb/in
Limiters (i)	0 mm	0 mm
Stroke	Kit mm	Kit mm
Limiters (e)	0 mm	0 mm

Notes:

