

Driver: \_\_\_\_\_ Date: \_\_\_\_\_ Event/Track: \_\_\_\_\_  
 Qualify: \_\_\_\_\_ Final: \_\_\_\_\_ Best Lap: \_\_\_\_\_

### TRACK TYPE

Grip Level High  Medium  Low   
 Type Tight  Open  Mixed   
 Condition Flat  Bumpy   
 Surface Clay  Astroturf  Carpet   
 Grass  \_\_\_\_\_   
 Weather \_\_\_\_\_

### TYRES

	FRONT	REAR
Tyres		
Wheels		
Inserts		
Notes:		

Notes:

### FRONT SUSPENSION

Ride Height \_\_\_\_\_ mm  
 Wheelbase 0  +1.5  +3.0  +4.5   
 Toe \_\_\_\_\_ deg In  Out   
 Camber at Ride Height \_\_\_\_\_ deg  
 Anti Roll Bar 0.9  1.0  1.1  1.2   
 Front Wing Y  N   
 Bump Steer Washers \_\_\_\_\_ mm  
 Pivot Block Height H  M  L   
 Steering Arm Kit  A  B  C

**KEY:** P = Plastic, A = Alloy, B = Brass, CF = Carbon Fibre, S2 = Schumacher Composite, M = Medium, S = Stiff, Sh = Short, H = High, L = Low, F = Front, R = Rear, Y = Yes, N = No

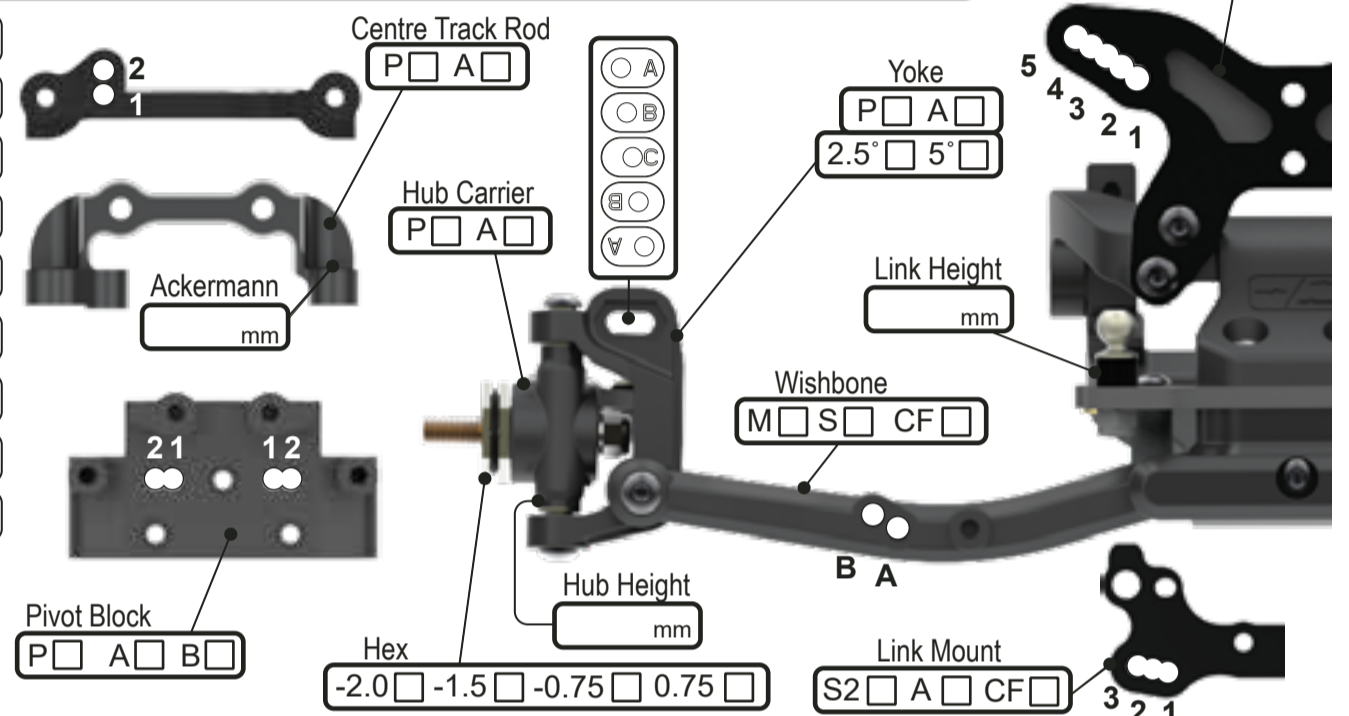

### REAR SUSPENSION

Ride Height \_\_\_\_\_ mm  
 Wheelbase 0  +2  +4  +6   
 Anti-Squat 1°  2°  3°  4°   
 Toe 4°  3.5°  3°  2.5°  2°  1.5°  1.0°  0.5°   
 Camber at Ride Height \_\_\_\_\_ deg  
 Anti Roll Bar 1.0  1.1  1.2  1.3  1.4   
 Wing Gurney Height \_\_\_\_\_ mm  
 Rearward Shock Position Y  N   
 Driveshaft Type CVD  U/J   
 Gearbox Type Laydown  Layback

**KEY:** P = Plastic, A = Alloy, B = Brass, CF = Carbon Fibre, S2 = Schumacher Composite, M = Medium, S = Stiff, Sh = Short, H = High, L = Low, F = Front, R = Rear, Y = Yes, N = No

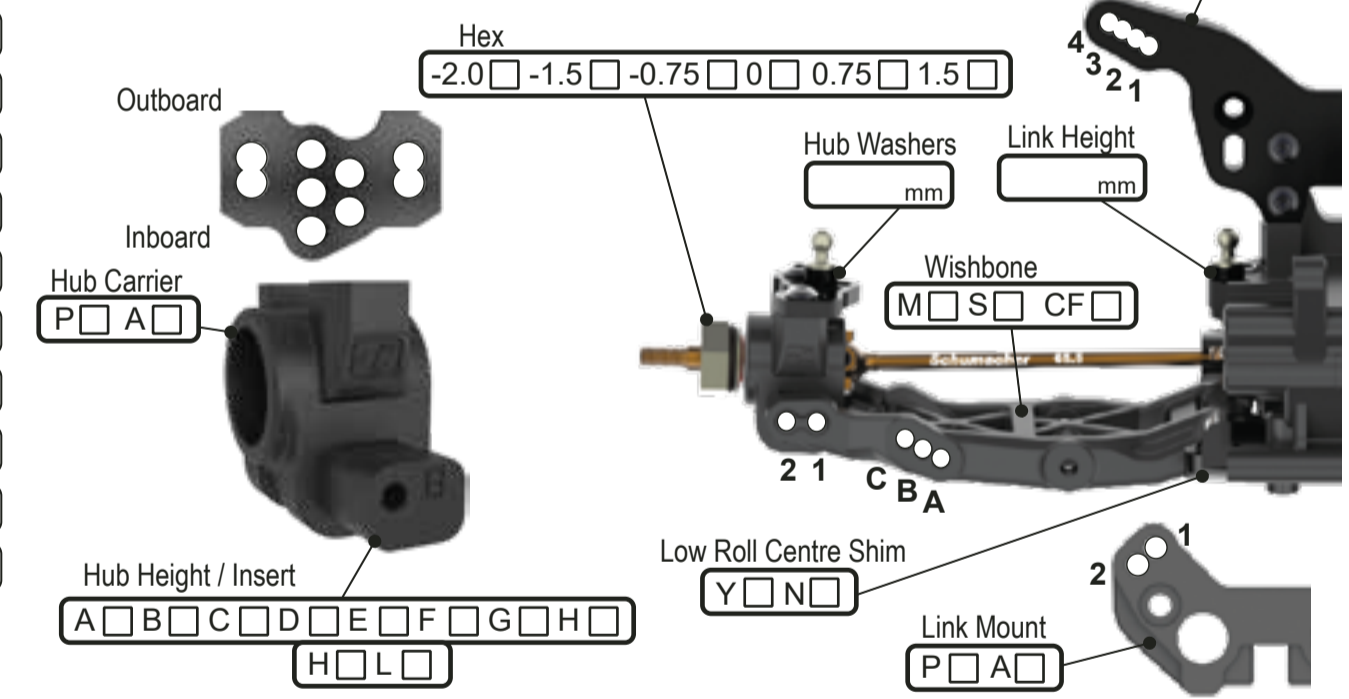

### TRANSMISSION

B = Ball, 2g = 2 Gear, 4g = 4 Gear  
 Diff Height H  M  L   
 Diff Oil \_\_\_\_\_ cSt  
 Diff Type B  2g  4g   
 Motor \_\_\_\_\_  
 Rotor Dia. \_\_\_\_\_ mm  
 Timing \_\_\_\_\_ deg  
 Pinion \_\_\_\_\_ t  
 Spur \_\_\_\_\_ t  
 Motor Plate A  CF   
 Lock Out Y  N   
 Slipper Plates 2  3

### CHASSIS

Chassis A  C/F   
 Chassis Insert 0mm  +5mm   
 LiPo Position 1  2  3  4  5  6  7  8   
 X Brace Y  N   
 Running Weight \_\_\_\_\_ g  
 Radio Tray 1  2  3   
 Notes:

### EQUIPMENT

E.S.C. \_\_\_\_\_  
 Servo \_\_\_\_\_  
 Receiver \_\_\_\_\_  
 Battery \_\_\_\_\_  
 Bodyshell \_\_\_\_\_

### WEIGHTS

Chassis F  R   
 Rear Strap F  R   
 Radio Tray Y  N   
 Under LiPo Y  N

### SHOCKS

**KEY:** i = Internal, e = External, V = Vented, S = Sealed, A = Aeration

	FRONT	REAR
Cap	V <input type="checkbox"/> S <input type="checkbox"/> A <input type="checkbox"/>	V <input type="checkbox"/> S <input type="checkbox"/> A <input type="checkbox"/>
Body		
Oil	_____ cSt	_____ cSt
Piston		
Spring	_____ lb/in	_____ lb/in
Limiters (i)	_____ mm	_____ mm
Stroke	_____ mm	_____ mm
Limiters (e)	_____ mm	_____ mm
Notes:		