

SET UP SHEET



Driver: Michal Orlovski Date: 11th June 2021 Event/Track: Utrecht, NL
 Qualify: Final: Best Lap: 36.068

TRACK TYPE

Grip Level High Medium Low
 Type Tight Open Mixed
 Condition Flat Bumpy Mixed
 Surface Clay Long Astro Carpet
 Grass Short Astro Mixed
 Weather 25°C

TYRES

	FRONT	REAR
Tyres	U6770	U6835
Wheels	U4661	U4366
Inserts	-	U6734

Notes:

Notes:

FRONT SUSPENSION

KEY: P = Plastic, A = Alloy, B = Brass, CF = Carbon Fibre, S2 = Schumacher Composite, M = Medium, S = Stiff, Sh = Short, H = High, L = Low, F = Front, R = Rear, Y = Yes, N = No

Ride Height 16 mm
 Wheelbase 0 +1.5 +3.0 +4.5
 Toe 1 deg In Out
 Camber at Ride Height -1.5 deg
 Anti Roll Bar 0.9 1.0 1.1 1.2
 Front Wing Y N
 Hub Height H M L
 Bump Steer Washers 2 mm
 Pivot Block Height H M L

Notes:

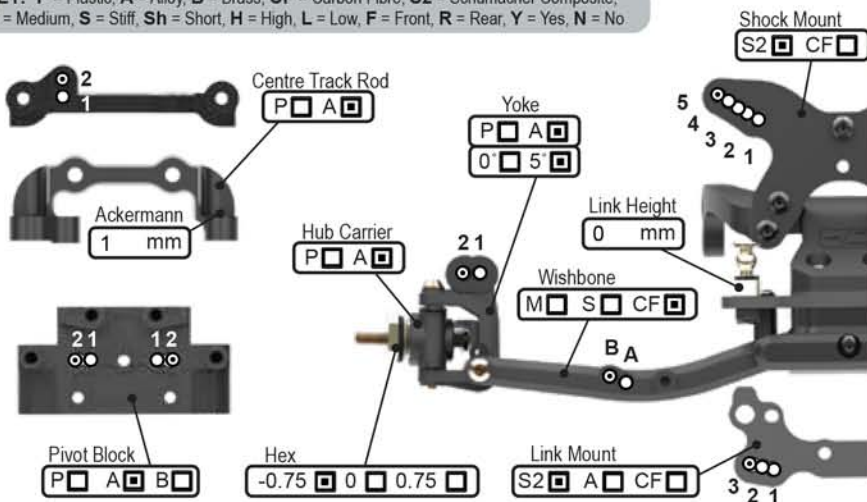

REAR SUSPENSION

KEY: P = Plastic, A = Alloy, B = Brass, CF = Carbon Fibre, S2 = Schumacher Composite, M = Medium, S = Stiff, Sh = Short, H = High, L = Low, F = Front, R = Rear, Y = Yes, N = No

Ride Height 16 mm
 Wheelbase Sh M L
 Anti-Squat 1° 2° 3° 4°
 Toe 4° 3.5° 3° 2.5° 2° 1.5° 1.0° 0.5°
 Camber at Ride Height -1.5 deg
 Anti Roll Bar 1.0 1.1 1.2 1.3 1.4
 Wing Gurney Height low mm
 Rearward Shock Position Only A B
 Driveshaft Type CVD U/J

Notes:

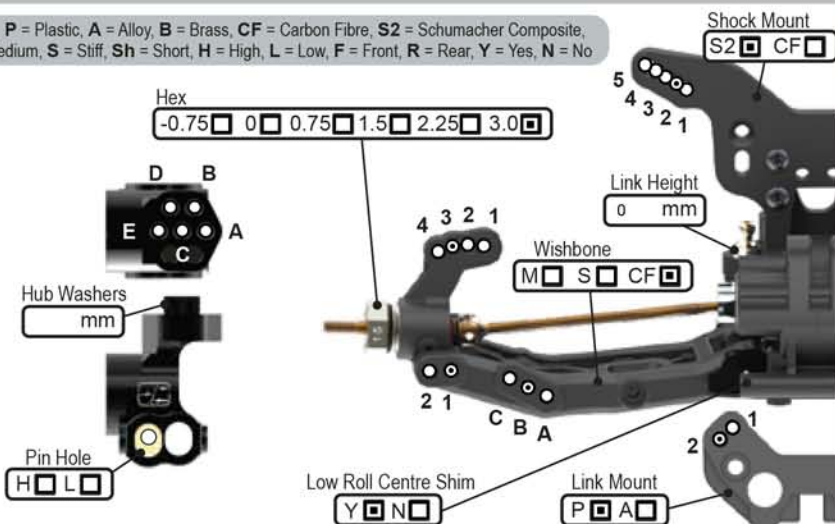

TRANSMISSION

Diff Height H M L
 Diff Oil 10k cSt
 Diff Type B 2g 4g
 Motor LRP X22 6.0t
 Rotor Dia. 12.7 mm
 Timing 19.5 deg
 Pinion 23 t
 Spur 80 t
 Motor Plate A CF
 Lock Out Y N
 Slipper Plates 2 3

CHASSIS

Chassis A C/F
 Side Pods S C/F
 Chassis Insert 0mm +5mm
 LiPo Position 1 2 3 4 5 6 7 8
 X Brace Y N
 Running Weight 9
 Radio Tray 1 2 3
 Notes:

EQUIPMENT

E.S.C. LRP FLOWX
 Servo POWERHDS15
 RX SANWARX-493
 LiPo LRP G4 4000mAh
 Bodysell KIT

WEIGHTS

Chassis F R
 Rear Strap F R
 Radio Tray Y N
 Under LiPo Y N

SHOCKS

KEY: i = Internal, e = External, V = Vented, S = Sealed, A = Aeration

	FRONT	REAR
Cap	V <input type="checkbox"/> S <input type="checkbox"/> A <input type="checkbox"/>	V <input type="checkbox"/> S <input type="checkbox"/> A <input type="checkbox"/>
Body	kashima	kashima
Oil	500 cSt	350 cSt
Piston	3x1.5mm	3x1.8mm
Spring	black hr lb/in	red lb/in
Limiters (i)	0 mm	0 mm
Stroke	22.2 mm	28.5 mm
Limiters (e)	0 mm	0 mm

Notes:

