

# SET UP SHEET



Driver: Jörg Miikael Tiit Date: 18.07.21 Event/Track: EOS Carpet Test  
 Qualify: Final: Best Lap:

## TRACK TYPE

Grip Level  High  Medium  Low   
 Type  Tight  Open  Mixed   
 Condition  Flat  Bumpy  Mixed   
 Surface  Clay  Long Astro  Carpet   
 Grass  Short Astro  Mixed   
 Weather 28 Degrees, 65% Humidity

## TYRES

	FRONT	REAR
Tyres	Low Cut Stagger Yellow PG	Cactus Yellow PG
Wheels		
Inserts		

Notes:

## Notes:

Klinik Rear Upper Arm Mount  
 Plastic Hub + Yoke for more initial turn in, aluminium for less

## FRONT SUSPENSION

KEY: P = Plastic, A = Alloy, B = Brass, CF = Carbon Fibre, S2 = Schumacher Composite, M = Medium, S = Stiff, Sh = Short, H = High, L = Low, F = Front, R = Rear, Y = Yes, N = No

Ride Height 13.5 mm  
 Wheelbase 0  +1.5  +3.0  +4.5   
 Toe 0.5 deg In  Out   
 Camber at Ride Height -1.5 deg  
 Anti Roll Bar 0.9  1.0  1.1  1.2   
 Front Wing Y  N   
 Hub Height H  M  L   
 Bump Steer Washers 3 mm  
 Pivot Block Height H  M  L

Notes:

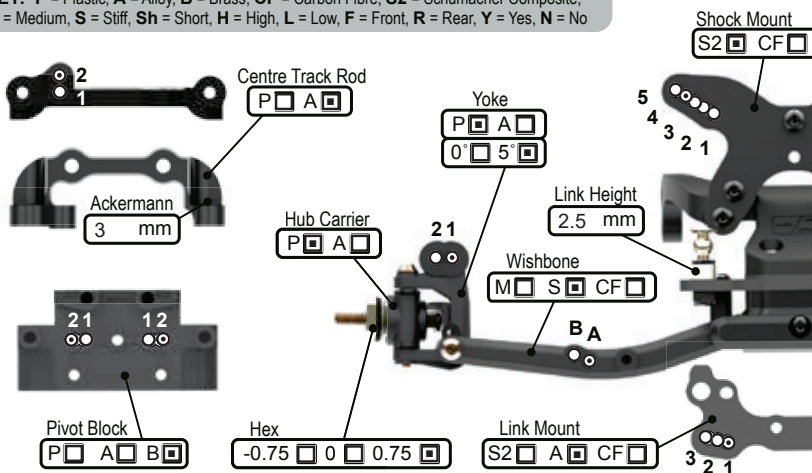

## REAR SUSPENSION

KEY: P = Plastic, A = Alloy, B = Brass, CF = Carbon Fibre, S2 = Schumacher Composite, M = Medium, S = Stiff, Sh = Short, H = High, L = Low, F = Front, R = Rear, Y = Yes, N = No

Ride Height 13 mm  
 Wheelbase Sh  M  L   
 Anti-Squat 1°  2°  3°  4°   
 Toe 4°  3.5°  3°  2.5°  2°  1.5°  1.0°  0.5°   
 Camber at Ride Height -1 deg  
 Anti Roll Bar 1.0  1.1  1.2  1.3  1.4   
 Wing Gurney Height Minimum mm  
 Rearward Shock Position Only A  B   
 Driveshaft Type CVD  U/J

Notes:

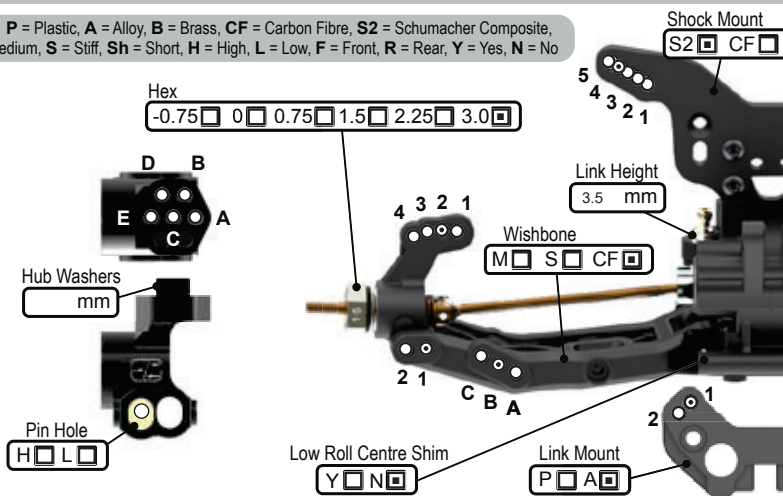

## TRANSMISSION

Diff Height H  M  L   
 Diff Oil 10K cSt  
 Diff Type B  2g  4g   
 Motor LRP X22 6.0  
 Rotor Dia. 12.7 mm  
 Timing 24.5 deg  
 Pinion 15 t  
 Spur 78 t  
 Motor Plate A  CF   
 Lock Out Y  N   
 Slipper Plates 2  3

## CHASSIS

Chassis A  C/F   
 Side Pods S  C/F   
 Chassis Insert 0mm  +5mm   
 LiPo Position 1  2  3  4  5  6  7  8   
 X Brace Y  N   
 Running Weight 9  
 Radio Tray 1  2  3   
 Notes:

## EQUIPMENT

E.S.C. Reedy 510R  
 Servo PowerHD Storm 7  
 RX  
 LiPo LRP 4000 Ultra LCG  
 Bodyshell Kit

## WEIGHTS

Chassis F  R   
 Rear Strap F  R   
 Radio Tray Y  N   
 Under LiPo Y  N

## SHOCKS

KEY: i = Internal, e = External, V = Vented, S = Sealed, A = Aeration

	FRONT	REAR
Cap	V <input type="checkbox"/> S <input type="checkbox"/> A <input type="checkbox"/>	V <input type="checkbox"/> S <input type="checkbox"/> A <input type="checkbox"/>
Body	Kashima	Kashima
Oil	550 cSt	500 cSt
Piston	3x1.6	3x1.6
Spring	Black lb/in	Black (RES) lb/in
Limiters (i)	0 mm	0 mm
Stroke	22 mm	28 mm
Limiters (e)	0 mm	0 mm

Notes:

Polished Shock Rods

