

# SET UP SHEET



Driver: Ben Smith Date: \_\_\_\_\_ Event/Track: Worksp  
 Qualify: \_\_\_\_\_ Final: \_\_\_\_\_ Best Lap: \_\_\_\_\_

## TRACK TYPE

Grip Level High  Medium  Low   
 Type Tight  Open  Mixed   
 Condition Flat  Bumpy  Mixed   
 Surface Clay  Long Astro  Carpet   
 Grass  Short Astro  Mixed   
 Weather \_\_\_\_\_

## TYRES

	FRONT	REAR
Tyres	Honeycomb	Honeycomb
Wheels		
Inserts		

Notes:

Notes:

## FRONT SUSPENSION

KEY: P = Plastic, A = Alloy, B = Brass, CF = Carbon Fibre, S2 = Schumacher Composite, M = Medium, S = Stiff, Sh = Short, H = High, L = Low, F = Front, R = Rear, Y = Yes, N = No

Ride Height 20 mm  
 Wheelbase 0  +1.5  +3.0  +4.5   
 Toe 1 deg In  Out   
 Camber at Ride Height -2 deg  
 Anti Roll Bar 0.9  1.0  1.1  1.2   
 Front Wing Y  N   
 Hub Height H  M  L   
 Bump Steer Washers 2 mm  
 Pivot Block Height H  M  L

Notes:

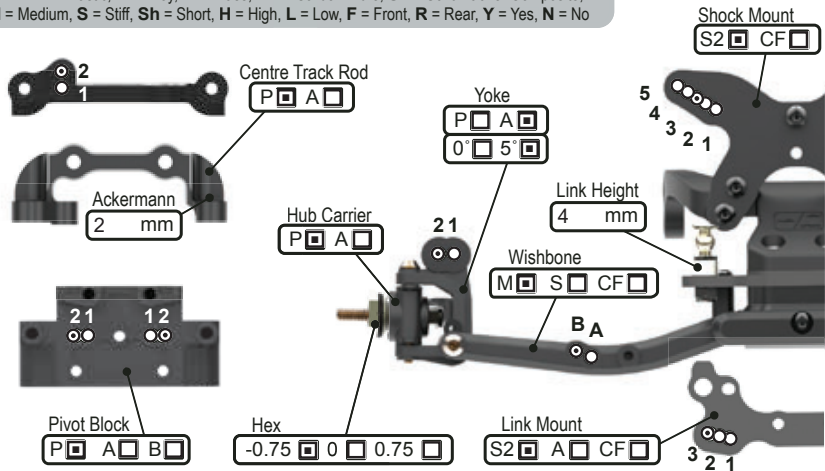

## REAR SUSPENSION

KEY: P = Plastic, A = Alloy, B = Brass, CF = Carbon Fibre, S2 = Schumacher Composite, M = Medium, S = Stiff, Sh = Short, H = High, L = Low, F = Front, R = Rear, Y = Yes, N = No

Ride Height 20 mm  
 Wheelbase Sh  M  L   
 Anti-Squat 1  2  3  4   
 Toe 4  3.5  3  2.5  2  1.5  1.0  0.5   
 Camber at Ride Height -2 deg  
 Anti Roll Bar 1.0  1.1  1.2  1.3  1.4   
 Wing Gurney Height \_\_\_\_\_ mm  
 Rearward Shock Position Only A  B   
 Driveshaft Type CVD  U/J

Notes:

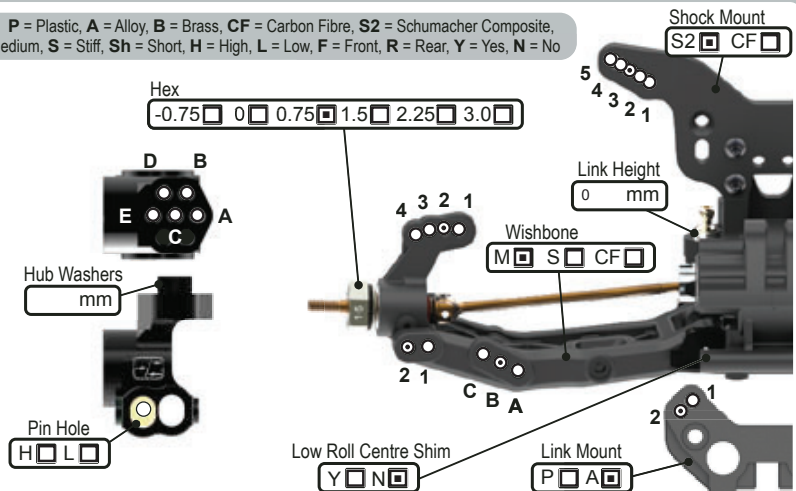

## TRANSMISSION

Diff Height H  M  L   
 Diff Oil cSt  
 Diff Type B  2g  4g   
 Motor HW 7.5t  
 Rotor Dia. Std. mm  
 Timing 20 deg  
 Pinion 24 t  
 Spur 80 t  
 Motor Plate A  CF   
 Lock Out Y  N   
 Slipper Plates 2  3

## CHASSIS

Chassis A  C/F   
 Side Pods S  C/F   
 Chassis Insert 0mm  +5mm   
 LiPo Position 1  2  3  4  5  6  7  8   
 X Brace Y  N   
 Running Weight \_\_\_\_\_ g  
 Radio Tray 1  2  3   
 Notes:

## EQUIPMENT

E.S.C. \_\_\_\_\_  
 Servo \_\_\_\_\_  
 RX \_\_\_\_\_  
 LiPo \_\_\_\_\_  
 Bodysell \_\_\_\_\_

## WEIGHTS

Chassis F  R   
 Rear Strap F  R   
 Radio Tray Y  N   
 Under LiPo Y  N

## SHOCKS

KEY: i = Internal, e = External, V = Vented, S = Sealed, A = Aeration

	FRONT	REAR
Cap	V <input type="checkbox"/> S <input type="checkbox"/> A <input type="checkbox"/>	V <input type="checkbox"/> S <input type="checkbox"/> A <input type="checkbox"/>
Body	Kashima	Kashima
Oil	450 cSt	350 cSt
Piston	1.8 2 hole	2.1 2 hole
Spring	Blue lb/in	Red lb/in
Limiters (i)	0 mm	0 mm
Stroke	22 mm	27 mm
Limiters (e)	0 mm	0 mm

Notes:

