

# SET UP SHEET



Driver: Ben Smith Date: N/A Event/Track: RHR Astro - Club night  
 Qualify: TQ Final: 1st Best Lap: N/A

## TRACK TYPE

Grip Level High  Medium  Low   
 Type Tight  Open  Mixed   
 Condition Flat  Bumpy  Mixed   
 Surface Clay  Long Astro  Carpet   
 Grass  Short Astro  Mixed   
 Weather Dry

## TYRES

	FRONT	REAR
Tyres	Yellow Cut Staggers	Yellow Darts
Wheels	Kit	Kit
Inserts	Schumacher Blue	Schumacher Blue

Notes:  
Outside pin cut off rear tyres

## Notes:

Recommend Ball Diff when sand comes up

## FRONT SUSPENSION

KEY: P = Plastic, A = Alloy, B = Brass, CF = Carbon Fibre, S2 = Schumacher Composite, M = Medium, S = Stiff, Sh = Short, H = High, L = Low, F = Front, R = Rear, Y = Yes, N = No

Ride Height 17 mm  
 Wheelbase 0 +1.5 +3.0 +4.5  
 Toe 0 deg In Out  
 Camber at Ride Height -1 deg  
 Anti Roll Bar 0.9 1.0 1.1 1.2  
 Front Wing Y N  
 Hub Height H M L  
 Bump Steer Washers 2 mm  
 Pivot Block Height H M L

Notes:

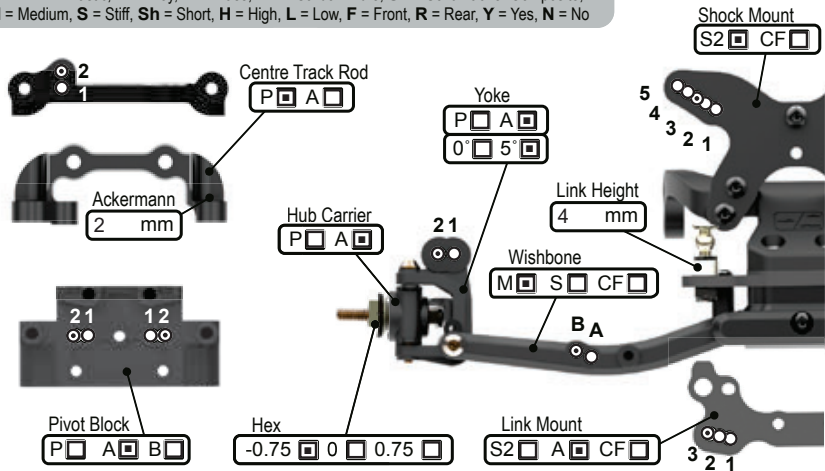

## REAR SUSPENSION

KEY: P = Plastic, A = Alloy, B = Brass, CF = Carbon Fibre, S2 = Schumacher Composite, M = Medium, S = Stiff, Sh = Short, H = High, L = Low, F = Front, R = Rear, Y = Yes, N = No

Ride Height 18 mm  
 Wheelbase Sh M L  
 Anti-Squat 1° 2° 3° 4°  
 Toe 4° 3.5° 3° 2.5° 2° 1.5° 1.0° 0.5°  
 Camber at Ride Height -1 deg  
 Anti Roll Bar 1.0 1.1 1.2 1.3 1.4  
 Wing Gurney Height mm  
 Rearward Shock Position Only A B  
 Driveshaft Type CVD U/J

Notes:

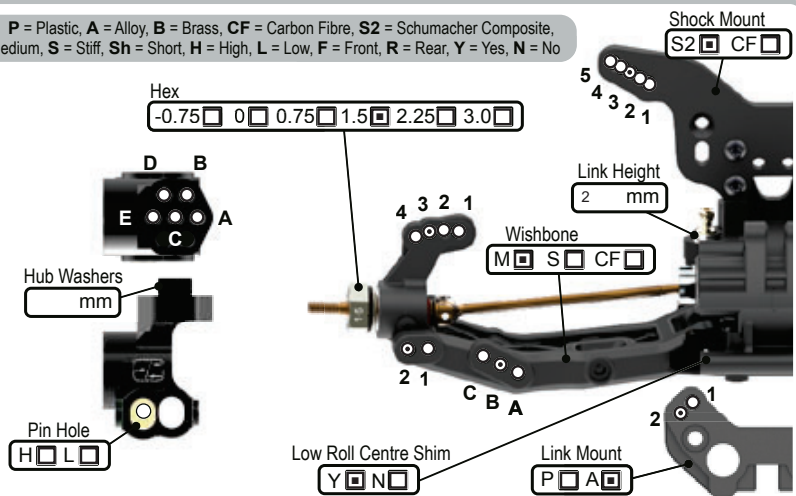

## TRANSMISSION

Diff Height H M L  
 Diff Oil 10k cSt  
 Diff Type B 2g 4g  
 Motor HW 6.5  
 Rotor Dia. 12.5 mm  
 Timing 20 deg  
 Pinion 21 t  
 Spur 76 t  
 Motor Plate A CF  
 Lock Out Y N  
 Slipper Plates 2 3

## CHASSIS

Chassis A C/F  
 Side Pods S C/F  
 Chassis Insert 0mm +5mm  
 LiPo Position 1 2 3 4 5 6 7 8  
 X Brace Y N  
 Running Weight 9  
 Radio Tray 1 2 3  
 Notes:  
30g under LiPo

## EQUIPMENT

E.S.C. HW XR10  
 Servo KO  
 RX Sanwa  
 LiPo Intellect 4200  
 Bodyshell Kit

## WEIGHTS

Chassis F R  
 Rear Strap F R  
 Radio Tray Y N  
 Under LiPo Y N

## SHOCKS

KEY: i = Internal, e = External, V = Vented, S = Sealed, A = Aeration

	FRONT	REAR
Cap	V S A	V S A
Body	Kashima	Kashima
Oil	550 cSt	450 cSt
Piston	2 hole 1.8	2 hole 2.1
Spring	Orange lb/in	Green lb/in
Limiters (i)	0 mm	0 mm
Stroke	22.5 mm	28.5 mm
Limiters (e)	0 mm	0 mm

Notes:

Black front spring when sand comes up

