

SET UP SHEET



Driver: Ben Smith Date: 24/07/2021 Event/Track: SOOM Series at Mendip
 Qualify: 3rd Final: 3rd Best Lap: N/A

TRACK TYPE

Grip Level High Medium Low
 Type Tight Open Mixed
 Condition Flat Bumpy Mixed
 Surface Clay Long Astro Carpet
 Grass Short Astro Mixed
 Weather Wet/Greasy

TYRES

	FRONT	REAR
Tyres	Silver Cut Stagger Ribs	Silver Mezzo
Wheels	Kit	Kit
Inserts	None	Tubby

Notes:

Notes:

E.S.C in blinky mode

FRONT SUSPENSION

KEY: P = Plastic, A = Alloy, B = Brass, CF = Carbon Fibre, S2 = Schumacher Composite, M = Medium, S = Stiff, Sh = Short, H = High, L = Low, F = Front, R = Rear, Y = Yes, N = No

Ride Height 19 mm
 Wheelbase 0 +1.5 +3.0 +4.5
 Toe 1.0 deg In Out
 Camber at Ride Height -1.5 deg
 Anti Roll Bar 0.9 1.0 1.1 1.2
 Front Wing Y N
 Hub Height H M L
 Bump Steer Washers 2.0 mm
 Pivot Block Height H M L

Notes:

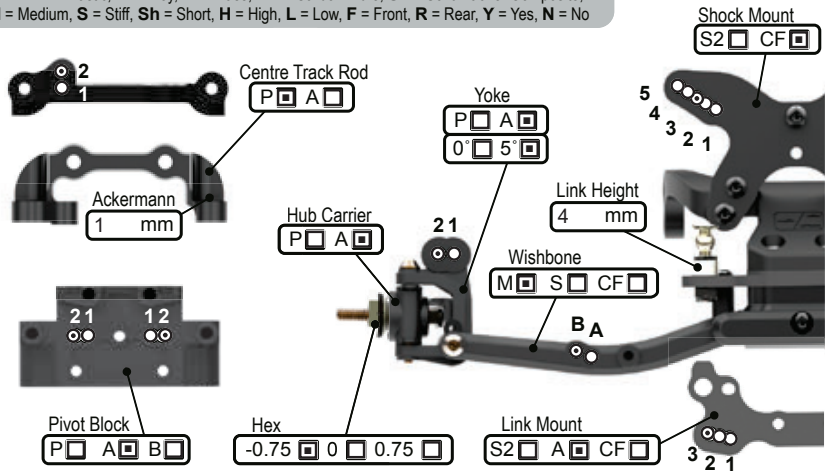

REAR SUSPENSION

KEY: P = Plastic, A = Alloy, B = Brass, CF = Carbon Fibre, S2 = Schumacher Composite, M = Medium, S = Stiff, Sh = Short, H = High, L = Low, F = Front, R = Rear, Y = Yes, N = No

Ride Height 19 mm
 Wheelbase Sh M L
 Anti-Squat 1° 2° 3° 4°
 Toe 4° 3.5° 3° 2.5° 2° 1.5° 1.0° 0.5°
 Camber at Ride Height -2.0 deg
 Anti Roll Bar 1.0 1.1 1.2 1.3 1.4
 Wing Gurney Height mm
 Rearward Shock Position Only A B
 Driveshaft Type CVD U/J

Notes:

Rear wishbones flipped

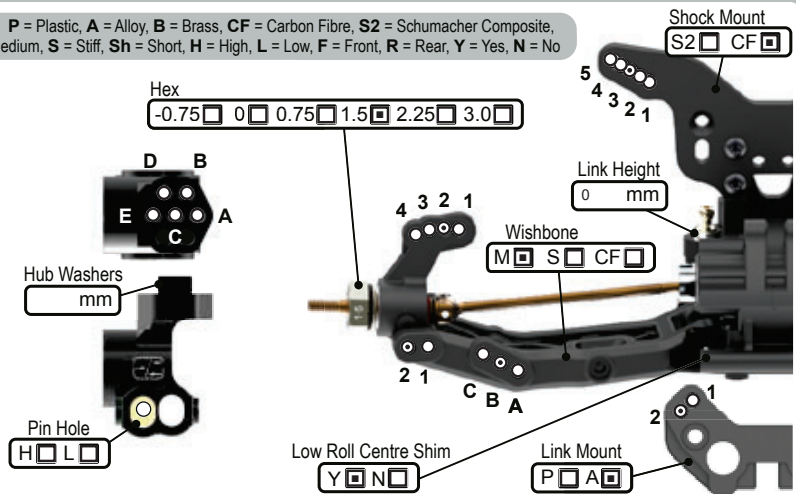

TRANSMISSION

Diff Height H M L
 Diff Oil cSt
 Diff Type B 2g 4g
 Motor HW 8.5t
 Rotor Dia. 12.5 mm
 Timing 20 deg
 Pinion 22 t
 Spur 76 t
 Motor Plate A CF
 Lock Out Y N
 Slipper Plates 2 3

CHASSIS

Chassis A C/F
 Side Pods S C/F
 Chassis Insert 0mm +5mm
 LiPo Position 1 2 3 4 5 6 7 8
 X Brace Y N
 Running Weight 0 9
 Radio Tray 1 2 3
 Notes:
 30g under lipo

EQUIPMENT

E.S.C. HW XR10
 Servo KO
 RX Sanwa
 LiPo Intellect 4200
 Bodyshell Kit

WEIGHTS

Chassis F R
 Rear Strap F R
 Radio Tray Y N
 Under LiPo Y N

SHOCKS

KEY: i = Internal, e = External, V = Vented, S = Sealed, A = Aeration

	FRONT	REAR
Cap	V S A	V S A
Body	Kit	Kit
Oil	450 cSt	350 cSt
Piston	2 hole 1.8	2 hole 2.1
Spring	Blue lb/in	Green lb/in
Limiters (i)	0 mm	0 mm
Stroke	22.2 mm	28.5 mm
Limiters (e)	0 mm	0 mm

Notes:

