



Driver: **Trish Neal** Date: **N/A** Event/Track: **Tests / Multiple**  
 Qualify: **N/A** Final: **N/A** Best Lap: **N/A**

**TRACK TYPE**

Grip Level High  Medium  Low   
 Type Tight  Open  Mixed   
 Condition Flat  Bumpy  Mixed   
 Surface Clay  Long Astro  Carpet   
 Grass  Short Astro  Mixed   
 Weather **Sunny**

**TYRES**

	FRONT	REAR
Tyres	<b>Yellow Stagger</b>	<b>Yellow MEZZO</b>
Wheels	<b>Kit</b>	<b>Kit</b>
Inserts	<b>None</b>	<b>Medium</b>

Notes:

Notes:

**FRONT SUSPENSION**

KEY: P = Plastic, A = Alloy, B = Brass, CF = Carbon Fibre, S2 = Schumacher Composite, M = Medium, S = Stiff, Sh = Short, H = High, L = Low, F = Front, R = Rear, Y = Yes, N = No

Ride Height **18** mm  
 Wheelbase **0**  +1.5  +3.0  +4.5   
 Toe **1.0** deg In  Out   
 Camber at Ride Height **-1.0** deg  
 Anti Roll Bar **0.9**  1.0  1.1  1.2   
 Front Wing Y  N   
 Hub Height H  M  L   
 Bump Steer Washers **2** mm  
 Pivot Block Height H  M  L

Notes:

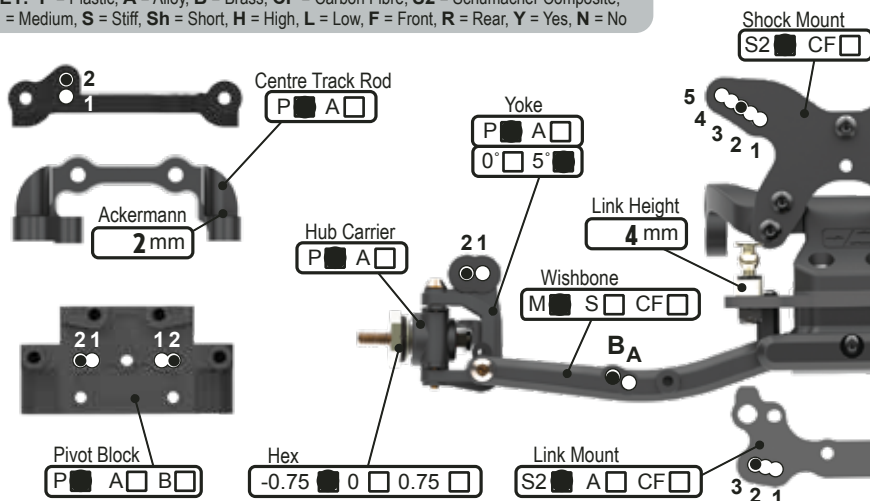

**REAR SUSPENSION**

KEY: P = Plastic, A = Alloy, B = Brass, CF = Carbon Fibre, S2 = Schumacher Composite, M = Medium, S = Stiff, Sh = Short, H = High, L = Low, F = Front, R = Rear, Y = Yes, N = No

Ride Height **18** mm  
 Wheelbase Sh  M  L   
 Anti-Squat **1°**  2°  3°  4°   
 Toe **4°**  3.5°  3°  2.5°  2°  1.5°  1.0°  0.5°   
 Camber at Ride Height **-1.0** deg  
 Anti Roll Bar **1.0**  1.1  1.2  1.3  1.4   
 Wing Gurney Height **5** mm  
 Rearward Shock Position Only A  B   
 Driveshaft Type CVD  U/J

Notes:

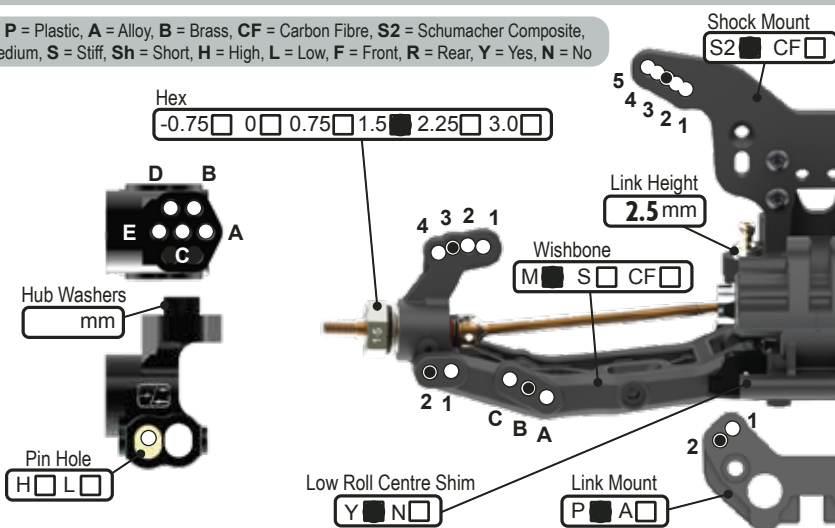

**TRANSMISSION**

Diff Height H  M  L   
 Diff Oil **12K** cSt  
 Diff Type B  2g  4g   
 Motor **7.0** Turn  
 Rotor Dia. **12.3** mm  
 Timing **20** deg  
 Pinion **23** t  
 Spur **80** t  
 Motor Plate A  CF   
 Lock Out Y  N   
 Slipper Plates **2**  3

**CHASSIS**

Chassis A  C/F   
 Side Pods S  C/F   
 Chassis Insert **0**mm  +5mm   
 LiPo Position  
 1  2  3  4  5  6  7  8   
 X Brace Y  N   
 Running Weight **1500g**  
 Radio Tray **1**  2  3   
 Notes:

**EQUIPMENT**

E.S.C. **LRP Flow X**  
 Servo **KO RSX 3**  
 RX **Sanwa**  
 LiPo **LRP 4000**  
 Bodysell **Kit**

**WEIGHTS**

Chassis F  R   
 Rear Strap F  R   
 Radio Tray Y  N   
 Under LiPo Y  N

**SHOCKS**

KEY: i = Internal, e = External, V = Vented, S = Sealed, A = Aeration

	FRONT	REAR
Cap	V <input type="checkbox"/> S <input type="checkbox"/> A <input checked="" type="checkbox"/>	V <input type="checkbox"/> S <input type="checkbox"/> A <input checked="" type="checkbox"/>
Body	<b>Kit</b>	<b>Kit</b>
Oil	<b>550</b> cSt	<b>400</b> cSt
Piston	<b>White 1.5 3 Hole</b>	<b>Red 1.7 3 Hole</b>
Spring	<b>Black 4.0</b> lb/in	<b>Green 2.2</b> lb/in
Limiters (i)	<b>0</b> mm	<b>0</b> mm
Stroke	<b>22.0</b> mm	<b>27.3</b> mm
Limiters (e)	<b>0</b> mm	<b>0</b> mm

Notes:

