



Driver: Matt Tunks Date: Event/Track: MKGP
 Qualify: 6 Final: 6 Best Lap:

TRACK TYPE

Grip Level High Medium Low
 Type Tight Open Mixed
 Condition Flat Bumpy Mixed
 Surface Clay Long Astro Carpet
 Grass Short Astro Mixed
 Weather indoor

TYRES

	Front	Rear
Tyres	HC	HC
Wheels	works	works
Inserts	tubby 4wd	cragg with wheel insert U907
Sidewall Glue	Front <input checked="" type="checkbox"/>	Rear <input type="checkbox"/>

Notes:
EOS carpet, large jumps

Notes:
Glue up to start of tread

FRONT SUSPENSION

KEY: P = Plastic, A = Alloy, B = Brass, F/G = Fibre Glass, C/F = Carbon Fibre, S2 = Schumacher Composite, M = Medium, S = Stiff, Sh = Short, H = High, L = Low, F = Front, R = Rear, Y = Yes, N = No

Ride Height 14 mm
 Toe -1 deg In Out
 Camber -1.5 deg
 Bump Steer Washers 0 mm
 Anti Roll Bar (U8818) Yes No
 Twin Bearing Kit (U8817) Yes No
 Carbon Track Rod (U8821) Yes No

Notes:
Cougar Classic front arms U8305
2mm kickup spacer
45g stick on weights
steering link in outer hub hole with shaved off inner for ball cup clearance

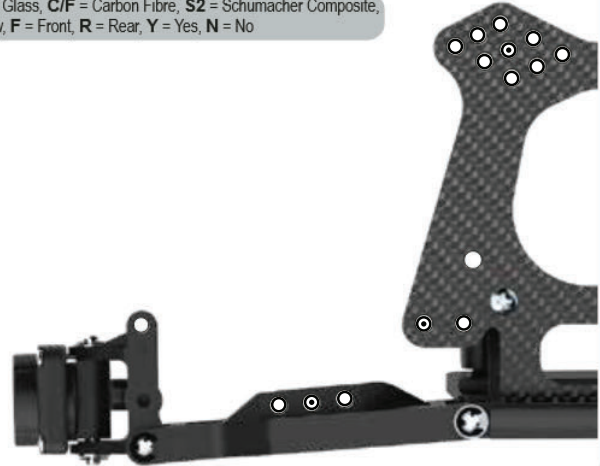

REAR SUSPENSION

KEY: P = Plastic, A = Alloy, B = Brass, F/G = Fibre Glass, C/F = Carbon Fibre, S2 = Schumacher Composite, M = Medium, S = Stiff, Sh = Short, H = High, L = Low, F = Front, R = Rear, Y = Yes, N = No

Ride Height 15 mm
 Camber 1.5 deg
 Anti-squat 0 mm
 Anti Roll Bar (U8819) Yes No
 Shock Tower Position Low Medium High
 Alloy Pivot Block Yes No

Notes:
ballraced rear roller shafts
vented motor cover
carbide diff balls and pro thrust race (U7281-U1954)

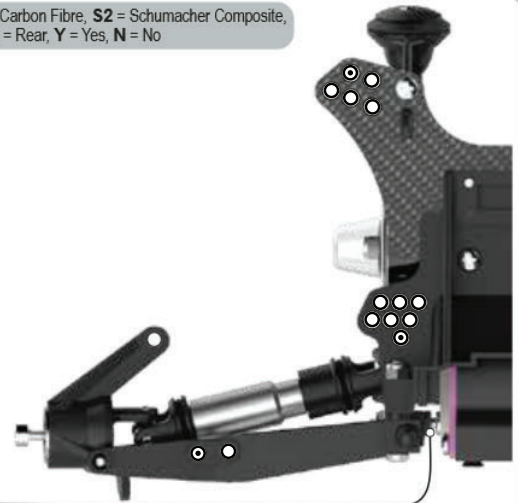

Rear Toe 2.5 mm

TRANSMISSION

Motor 10.5 g3r
 Rotor Dia. mm
 Timing 42 deg
 Pinion 23 t
 Spur 89 t
 Upgraded Slipper Y N

Notes:

CHASSIS

Running Weight g
 Battery Position Fwd Rwd
 Wing Mount Type LD3

Notes:

EQUIPMENT

E. S.C. HW XR10 pro
 Servo Aerox mp1
 RX sanwa
 LiPo intellect 4800
 Bodysell works

WEIGHTS

Under LiPo Y N

Notes:
longways battery with stiffener bar

SHOCKS

KEY: i = Internal, e = External

	FRONT				REAR			
Oil	550	cSt	450	cSt				
Piston Holes Open (F)	1 <input type="checkbox"/>	2 <input type="checkbox"/>	3 <input type="checkbox"/>	4 <input type="checkbox"/>				
Piston Holes Open (R)	1 <input type="checkbox"/>	2 <input type="checkbox"/>	3 <input type="checkbox"/>	4 <input type="checkbox"/>				
Spring	orange cr63 lb/in				black cr188 lb/in			
Limiters (i)	mm				mm			
Stroke	mm				mm			
Limiters (e)	mm				mm			

Notes:
Big Bore shock set, long ball cups on rear shocks
droop set to align wheel bolts with lower part of the chassis plate.
front 2x1.7 vrp black washer
rear 2x1.8 vrp blue washer