

Driver & Event	
Name	
Date	Event
Weather	
Result	

Track Conditions	
Grip Level	High <input type="checkbox"/> Med <input type="checkbox"/> Low <input type="checkbox"/>
Type	Tight <input type="checkbox"/> Open <input type="checkbox"/> Mixed <input type="checkbox"/>
Surface	Clay <input type="checkbox"/> Astro <input type="checkbox"/> Grass <input type="checkbox"/> Mixed <input type="checkbox"/> Carpet <input type="checkbox"/>
Condition	Smooth <input type="checkbox"/> Bumpy <input type="checkbox"/>

Differential	
Diff Oil F.....cSt	R.....cSt
Dif Height F	High <input type="checkbox"/> Mid <input type="checkbox"/> Low <input type="checkbox"/>
Dif Height R	High <input type="checkbox"/> Mid <input type="checkbox"/> Low <input type="checkbox"/>

Electrics & Chassis	
E.S.C	
Servo	
Reciever	Lipo
Shorty LiPo	Front <input type="checkbox"/> Middle <input type="checkbox"/> Rear <input type="checkbox"/>
Centre Topdeck	Yes <input type="checkbox"/> No <input type="checkbox"/>
Front Topdeck Thickness	2.5mm <input type="checkbox"/> 3.0mm <input type="checkbox"/>
Rear Topdeck Thickness	2.5mm <input type="checkbox"/> 3.0mm <input type="checkbox"/>

Wheels & Tyres	
Rr Tyre	
Rr Wheel	
Rr Insert	
Fr Tyre	
Fr Wheel	
Fr Insert	

Motor & Gearing	
Motor	
Rotor Diameter	mm
Timing	Deg
Spur	
Pinion	

Other settings	
Car Weight	g
Alloy Wing Mount	High <input type="checkbox"/> Low <input type="checkbox"/>
Rear Wing Gurney Height	mm
Front Wing	Small <input type="checkbox"/> Big <input type="checkbox"/>
Front Wing Gurney Height	mm
Slipper	2Plate <input type="checkbox"/> 3Plate <input type="checkbox"/> 4Plate <input type="checkbox"/>
Rear Hex	0 <input type="checkbox"/> 0.75 <input type="checkbox"/> 1.5 <input type="checkbox"/>
Front Hex	0 <input type="checkbox"/> 0.75 <input type="checkbox"/> 1.5 <input type="checkbox"/>

Front Shocks	
Oil.....cSt	Spring <input type="checkbox"/> Shock Cap <input type="checkbox"/> Sealed <input type="checkbox"/> Vented <input type="checkbox"/> Aeration <input type="checkbox"/>
Piston.....lb/in	
Piston.....Drilled <input type="checkbox"/>	Hole Size.....mm
Internal Limiters.....mm	Kashima Body No <input type="checkbox"/> Yes <input type="checkbox"/>

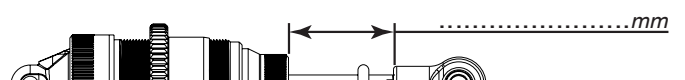

Rear Shocks	
Oil.....cSt	Spring <input type="checkbox"/> Shock Cap <input type="checkbox"/> Sealed <input type="checkbox"/> Vented <input type="checkbox"/> Aeration <input type="checkbox"/>
Piston.....lb/in	
Piston.....Drilled <input type="checkbox"/>	Hole Size.....mm
Internal Limiters.....mm	Kashima Body No <input type="checkbox"/> Yes <input type="checkbox"/>
Shock Stand Off Spacing.....mm	

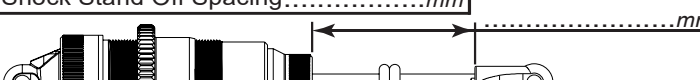

Front Suspension	
Toe:.....Deg	Anti Roll Bar: None <input type="checkbox"/> 1.2 <input type="checkbox"/> 1.4 <input type="checkbox"/> 1.6 <input type="checkbox"/> 1.8 <input type="checkbox"/> 2.0 <input type="checkbox"/>
Yoke: 8° <input type="checkbox"/> 10° <input type="checkbox"/> 12° <input type="checkbox"/>	Ride Height:.....mm
Bump Steer Washer:.....mm	Camber at Ride Height:.....Deg
Hub Spacer: High <input type="checkbox"/> Low <input type="checkbox"/>	Link Washer.....mm
Driveshaft: Kit <input type="checkbox"/> Roche <input type="checkbox"/>	Wheelbase: Short <input type="checkbox"/> Long <input type="checkbox"/>
	Shock Mount: C/F <input type="checkbox"/> S2 <input type="checkbox"/>
	Pin Angle: 8° <input type="checkbox"/> 10° <input type="checkbox"/> 12° <input type="checkbox"/>
	Pin Width: Narrow <input type="checkbox"/> Mid <input type="checkbox"/> Wide <input type="checkbox"/>

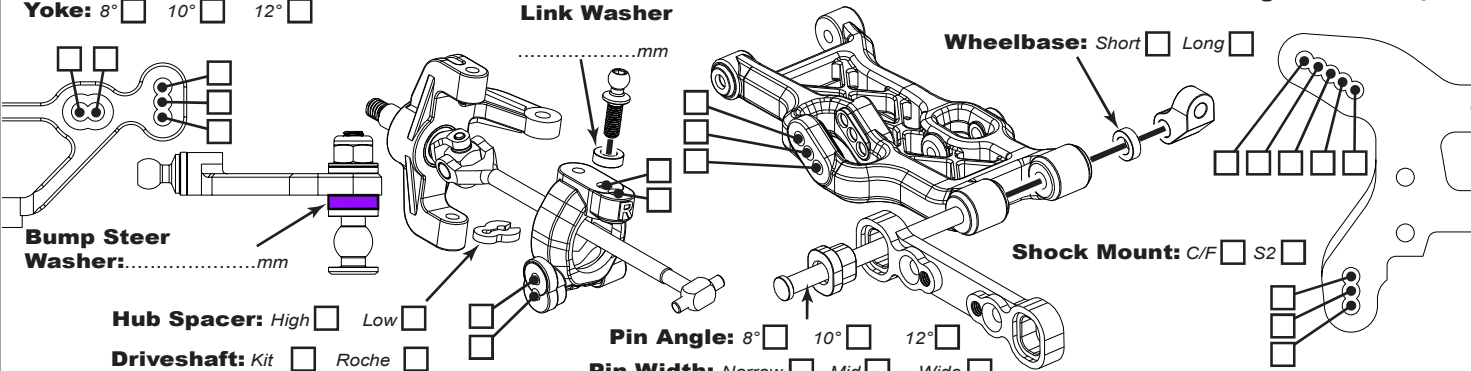

Rear Suspension	
Toe In (Kit Blocks): 3° <input type="checkbox"/> 2.5° <input type="checkbox"/>	Anti Roll Bar: None <input type="checkbox"/> 1.2 <input type="checkbox"/> 1.4 <input type="checkbox"/> 1.6 <input type="checkbox"/> 1.8 <input type="checkbox"/> 2.0 <input type="checkbox"/>
Toe In (3.5°/2° Blocks): 3.5° <input type="checkbox"/> 2° <input type="checkbox"/>	Ride Height:.....mm
Toe In (4°/1.5° Blocks): 4° <input type="checkbox"/> 1.5° <input type="checkbox"/>	Camber at Ride Height:.....Deg
Anti-squat: 1° <input type="checkbox"/> 2° <input type="checkbox"/> 3° <input type="checkbox"/> 4° <input type="checkbox"/>	Wheelbase: Short <input type="checkbox"/> Med <input type="checkbox"/> Long <input type="checkbox"/>
Rear Strap: High Pin (With front Riser) <input type="checkbox"/> Low Pin (Kit) <input type="checkbox"/>	Shock Mount: C/F <input type="checkbox"/> S2 <input type="checkbox"/>
Hub Carrier: Kit <input type="checkbox"/> Alloy <input type="checkbox"/>	Wing Mount: Alloy <input type="checkbox"/> Kit <input type="checkbox"/>
Brass insert: Hi-Pin <input type="checkbox"/> Low-Pin <input type="checkbox"/>	Wing Washer: No <input type="checkbox"/> Yes <input type="checkbox"/>
	Hub Washers:.....mm
	Link Washer.....mm
	Link Mount: Kit <input type="checkbox"/> Alloy <input type="checkbox"/>

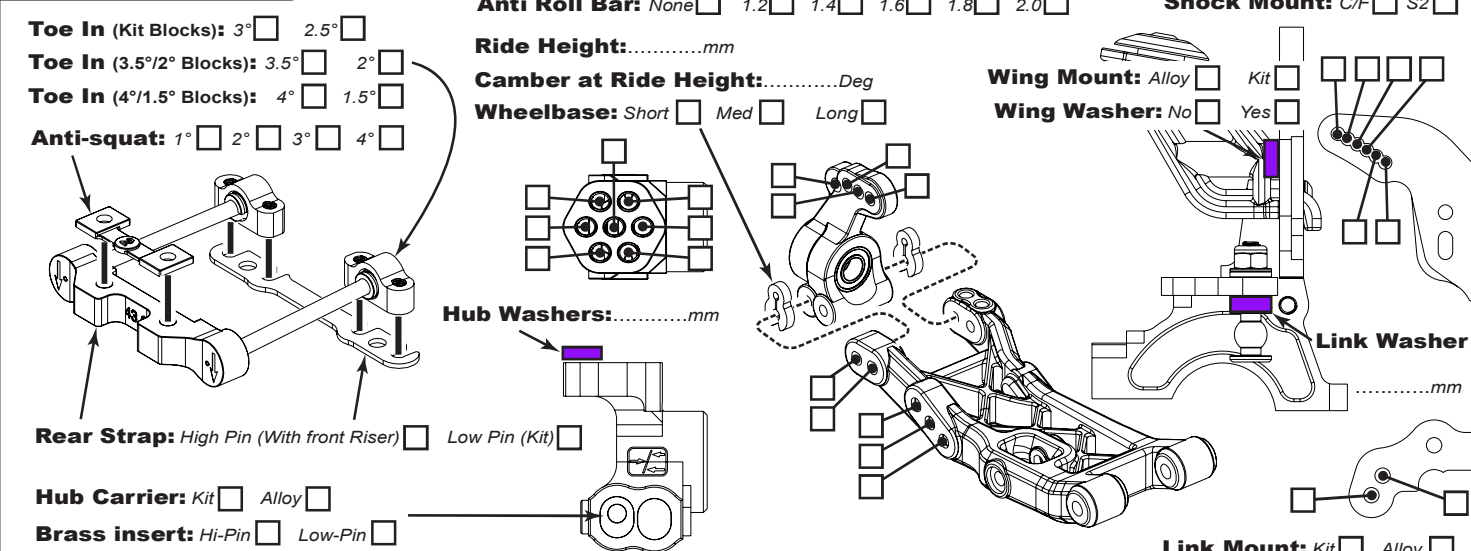

**Notes**