

Driver: Michal Orlovski Date: September 2024 Event/Track: EC 2024
 Qualify: 2nd Final: 2nd Best Lap: 18.4

TRACK TYPE

Grip Level High Medium Low
 Type Tight Open Mixed
 Condition Flat Bumpy Mixed
 Surface Clay Long Astro Carpet
 Grass Short Astro Mixed
 Weather

TYRES

	FRONT	REAR
Tyres	Cactus Fusion 2	Cactus
Wheels	Schumacher	Schumacher
Inserts	Med	Med

Notes:

Notes:

Recon Steering
 Jconcepts Ti screws, turnbuckles, NMB bearings
 L1 front tower
 43.6 rear hangars
 LD3 rear tower
 67.3 U/J driveshaft
 E hub insert flipped hub high
 Wide rear camber plate

FRONT SUSPENSION

KEY: P = Plastic, A = Alloy, B = Brass, CF = Carbon Fibre, S2 = Schumacher Composite, M = Medium, S = Stiff, Sh = Short, H = High, L = Low, F = Front, R = Rear, Y = Yes, N = No

Ride Height 12 mm
 Wheelbase Long Short
 Toe 1 deg In Out
 Camber at Ride Height -2 deg
 Anti Roll Bar None 1.2 1.4 1.6 1.8 1.9 2.0 2.1
 Hub Height H L
 Bump Steer Washers 0 mm
 Hingepin Height H L
 Driveshaft Type Roche U/J
 Steering Arm Kit 1 Dot 2 Dot 3 Dot
 Track Narrow Mid Wide
 Front Strap A B

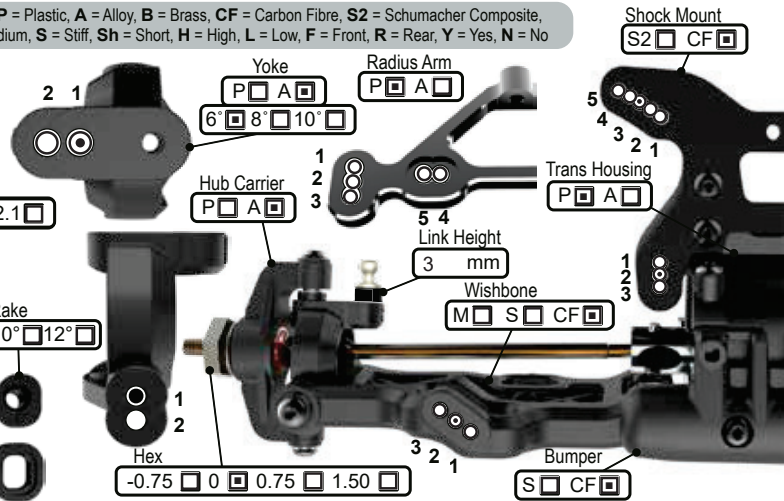

REAR SUSPENSION

KEY: P = Plastic, A = Alloy, B = Brass, CF = Carbon Fibre, S2 = Schumacher Composite, M = Medium, S = Stiff, Sh = Short, H = High, L = Low, F = Front, R = Rear, Y = Yes, N = No

Ride Height 12 mm
 Wheelbase Sh M L
 Anti-Squat 1° 2° 3° 4°
 Toe 4° 3.5° 3° 2.5° 2° 1.5° 1.0° 0.5°
 Camber at Ride Height -2 deg
 Anti Roll Bar None 1.2 1.4 1.6 1.8 1.9 2.0 2.1
 Wing Gurney Height mm
 Driveshaft Type CVD U/J
 Gearbox Riser Y N
 Hub Height / Insert A B C D
 Pin Height H L
 High Pin Requires U8453

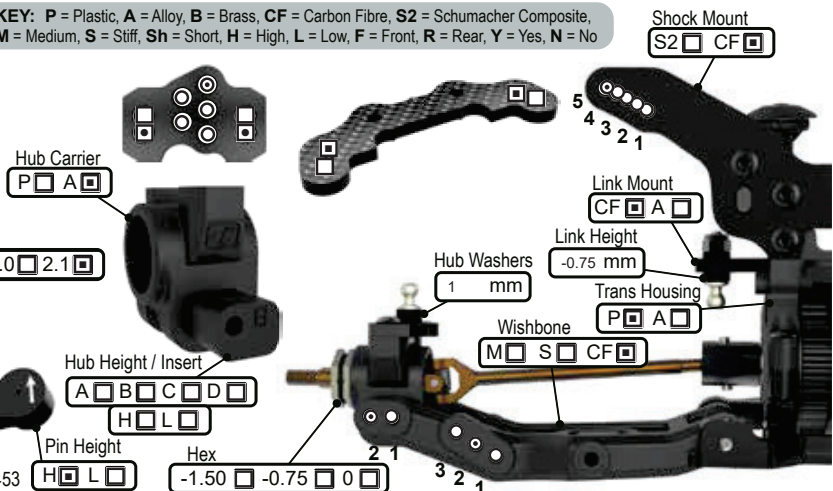

CHASSIS

Chassis A C/F
 LiPo Position R F
 Running Weight 1600 g
 Front Topdeck S2 CF

Motor 4.5t
 Rotor Dia. 12.5 mm
 Timing 30 deg

Diff Height Front H M L Diff Height Rear H M L
 Diff Oil Front 50k cSt Diff Oil Rear 80k cSt
 Diff Gears Front 2 4 Diff Gears Rear 2 4
 Diff Body Front P A CF Diff Body Rear P A CF

WEIGHTS

Radio Tray Y N
 ESC Tray Y N
 Pinion 18 t
 Spur 83 t
 R.O.S Y N
 Lock Out Y N
 Slipper Plates 2 3

EQUIPMENT

E.S.C. HW G2S
 Servo PowerHD GTS-3
 RX Sanwa
 LiPo Sunpadow 4600
 Bodysell JC S15
 Wing JC 6.5

TRANSMISSION

SHOCKS

KEY: i = Internal, e = External, V = Vented, S = Sealed, A = Aeration

	FRONT	REAR
Cap	V <input type="checkbox"/> S <input type="checkbox"/> A <input type="checkbox"/>	V <input type="checkbox"/> S <input type="checkbox"/> A <input type="checkbox"/>
Kashima	Y <input type="checkbox"/> N <input type="checkbox"/>	Y <input type="checkbox"/> N <input type="checkbox"/>
Oil	700 cSt	500 cSt
Piston	2x1.6	2x1.8
Spring	black hr lb/in	black hr lb/in
Limiters (i)	0 mm	0 mm
Stroke	25 mm	28.5 mm
Limiters (e)	0 mm	0 mm
Shock Stand Off	5 mm	

Notes:

