

Driver: Michal Orlowski Date: Nov 19, 2023 Event: Florida Carpet Champs
 Qualify: 2nd Final: 2nd Best Lap: 15.881 Track: Beachline Raceway

TRACK TYPE

Grip Level High Medium Low
 Type Tight Open Mixed
 Condition Flat Bumpy Mixed
 Surface Clay Long Astro Carpet
 Grass Short Astro Mixed
 Weather

TYRES

	FRONT	REAR
Tyres	JC Pin Swag 4wd	JC Fuzz Bite
Wheels	JC	JC
Inserts	JC	JC

Notes:

Notes:

55mm rear wide plate

Whitz Racing turnbuckles, bearings and screws

MR33 motor fan

FRONT SUSPENSION

KEY: P = Plastic, A = Alloy, B = Brass, CF = Carbon Fibre, S2 = Schumacher Composite, M = Medium, S = Stiff, Sh = Short, H = High, L = Low, F = Front, R = Rear, Y = Yes, N = No

Ride Height
 Wheelbase Long Short
 Toe Out
 Camber at Ride Height
 Anti Roll Bar None 1.2 1.4 1.6 1.8 1.9 2.0 2.1
 Hub Height L
 Bump Steer Washers
 Hingepin Height L
 Driveshaft Type Roche U/J
 Steering Arm Kit 1 Dot 2 Dot 3 Dot
 Track Narrow Mid Wide
 Front Strap A B

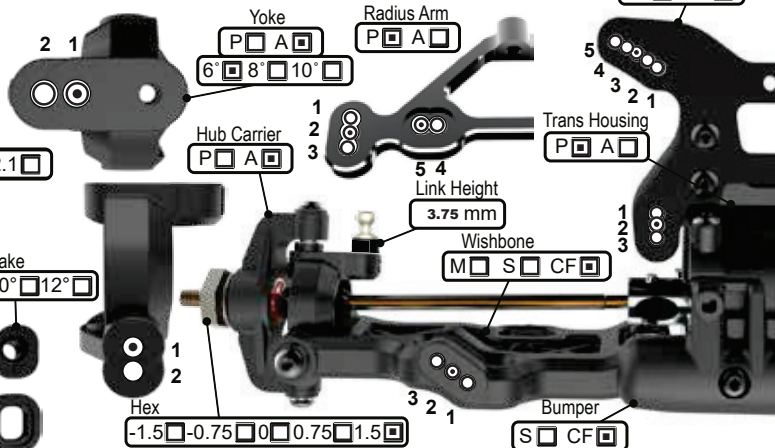

REAR SUSPENSION

KEY: P = Plastic, A = Alloy, B = Brass, CF = Carbon Fibre, S2 = Schumacher Composite, M = Medium, S = Stiff, Sh = Short, H = High, L = Low, F = Front, R = Rear, Y = Yes, N = No

Ride Height
 Wheelbase Sh Sh3-1 M L3-1 L
 Anti-Squat 1° 2° 3° 4°
 Toe 4° 3.5° 3° 2.5° 2° 1.5° 1.0° 0.5°
 Camber at Ride Height
 Anti Roll Bar None 1.2 1.4 1.6 1.8 1.9 2.0 2.1
 Wing Gurney Height
 Driveshaft Type CVD U/J
 Gearbox Riser Y N
 Hub Height / Insert A B C D
 H L
 Pin Height L
 High Pin Requires U8453

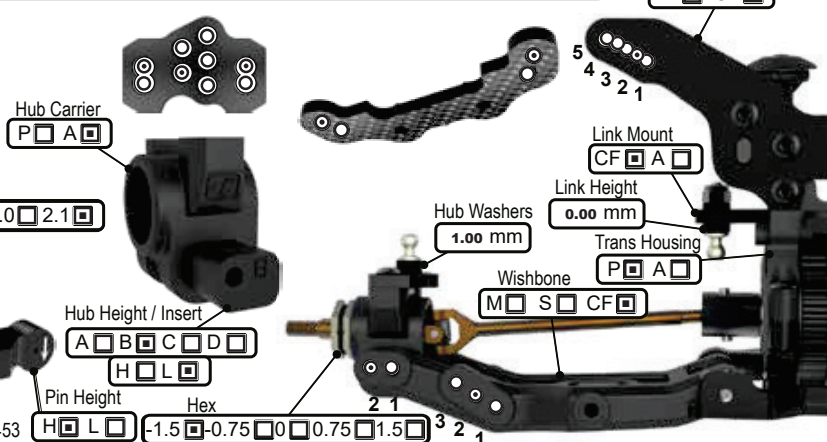

CHASSIS

Chassis A C/F
 LiPo Position R F
 Running Weight
 Front Topdeck S2 CF

Motor HW 4,5t
 Rotor Dia.
 Timing

Diff Height Front H M L Diff Height Rear H M L
 Diff Oil Front Diff Oil Rear
 Diff Gears Front 2 4 Diff Gears Rear 2 4
 Diff Body Front P A CF Diff Body Rear P A CF

WEIGHTS

Radio Tray Y N
 ESC Tray Y N
 Pinion
 Spur
 R.O.S Y N
 Lock Out Y N
 Slipper Plates 2 3

EQUIPMENT

E.S.C. HW G2S
 Servo PowerHD GTS-3
 RX Sanwa RX-492I
 LiPo Sunpadow 3800
 Bodysell JC S2
 Wing JC 6.5in

TRANSMISSION

SHOCKS

KEY: i = Internal, e = External, V = Vented, S = Sealed, A = Aeration

	FRONT	REAR
Cap	V <input type="checkbox"/> S <input type="checkbox"/> A <input type="checkbox"/>	V <input type="checkbox"/> S <input type="checkbox"/> A <input type="checkbox"/>
Kashima Body	Y <input type="checkbox"/> N <input type="checkbox"/>	Y <input type="checkbox"/> N <input type="checkbox"/>
Oil	<input type="text" value="600 cSt"/>	<input type="text" value="550 cSt"/>
Piston	<input type="text" value="2x1.6"/>	<input type="text" value="2x1.8"/>
Spring	<input type="text" value="blue hr lb/in"/>	<input type="text" value="blue hr lb/in"/>
Limiters (i)	<input type="text" value="0.00 mm"/>	<input type="text" value="0.00 mm"/>
Stroke	<input type="text" value="21.80 mm"/>	<input type="text" value="28.00 mm"/>
Limiters (e)	<input type="text" value="mm"/>	<input type="text" value="mm"/>
Shock Top Stand Off Spacing:	<input type="text" value="3.0 mm"/>	

Notes:

