

CATLR PURE BEAST SETUP SHEET

Driver: _____ Date: _____ Event/Track: _____
 Qualify: _____ Final: _____ Best Lap: _____

TRACK TYPE

Grip Level High Medium Low
 Layout Tight Open Mixed
 Condition Flat Bumpy
 Surface Clay Astroturf Carpet
 Grass
 Weather _____

TYRES

	FRONT	REAR
Tyres	_____	_____
Wheels	_____	_____
Inserts	_____	_____

Notes _____

Notes _____

FRONT SUSPENSION

Ride Height _____ mm
 Wheelbase Long Short
 Toe deg In Out
 Camber at Ride Height _____ deg
 Anti Roll Bar None 1.2 1.4 1.6 1.8 1.9 2.0 2.1
 Hub Height High Low
 Bump Steer Washers _____ mm
 Hingepin Height High Low
 Driveshaft Type Roche U/J
 Steering Arm Kit 1 Dot 2 Dot 3 Dot
 Track Narrow Mid Wide
 Front Strap A B

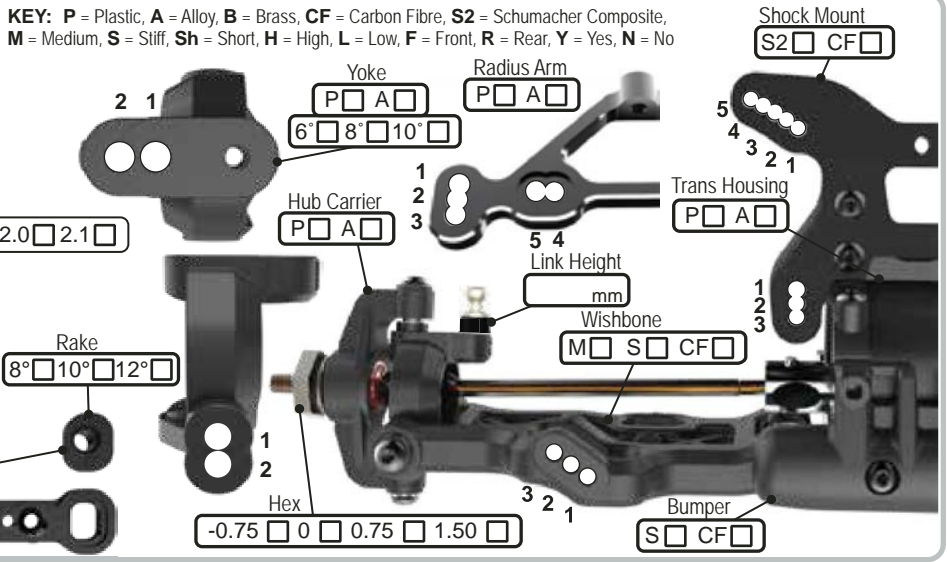

REAR SUSPENSION

Ride Height _____ mm
 Wheelbase Short Medium Long
 Anti-Squat 1° 2° 3° 4°
 Toe 4° 3.5° 3° 2.5° 2° 1.5° 1.0° 0.5°
 Camber at Ride Height _____ deg
 Anti Roll Bar None 1.2 1.4 1.6 1.8 1.9 2.0 2.1
 Wing Gurney Height _____ mm
 Driveshaft Type CVD U/J
 Gearbox Riser Y N
 Hub Height / Insert A B C D
 H L
 Pin Height High Low
 High Pin Requires U8453

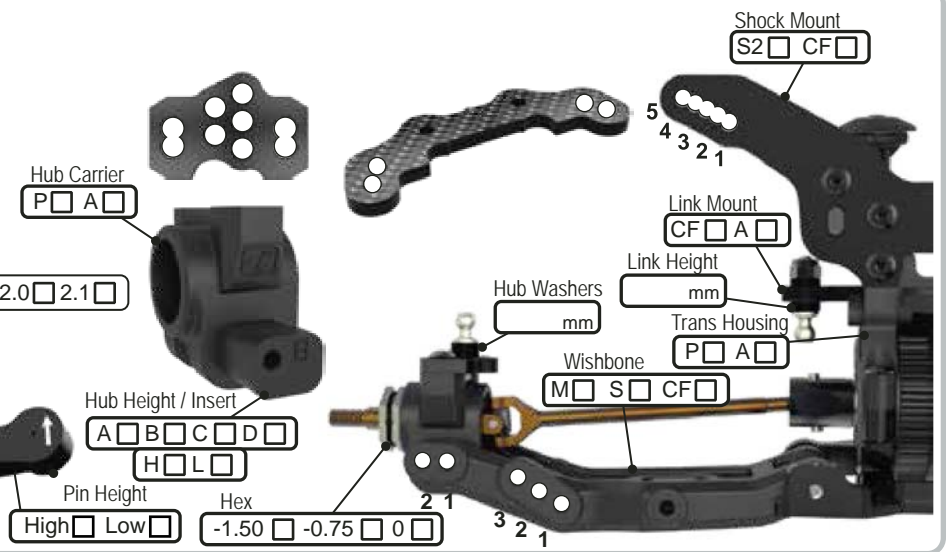

CHASSIS

Chassis A C/F
 LiPo Position R F
 Running Weight _____ g
 Front Topdeck S2 CF
 Motor _____
 Rotor Dia. _____ mm
 Timing _____ deg
 Diff Height Front H M L Diff Height Rear H M L
 Diff Oil Front _____ cSt Diff Oil Rear _____ cSt
 Diff Gears Front 2 4 Diff Gears Rear 2 4
 Diff Body Front P A CF Diff Body Rear P A CF

WEIGHTS

Radio Tray Y N
 ESC Tray Y N
 Pinion _____ t
 Spur _____ t
 R.O.S Y N
 Lock Out Y N
 Slipper Plates 2 3

EQUIPMENT

E.S.C. _____
 Servo _____
 Receiver _____
 LiPo _____
 Bodyshell _____
 Wing _____

TRANSMISSION

Notes _____

SHOCKS

KEY: i = Internal, e = External, V = Vented, S = Sealed, A = Aeration

	FRONT	REAR
Cap	V <input type="checkbox"/> S <input type="checkbox"/> A <input type="checkbox"/>	V <input type="checkbox"/> S <input type="checkbox"/> A <input type="checkbox"/>
Kashima	Y <input type="checkbox"/> N <input type="checkbox"/>	Y <input type="checkbox"/> N <input type="checkbox"/>
Oil	_____ cSt	_____ cSt
Piston	_____	_____
Spring	_____ lb/in	_____ lb/in
Limiters (i)	_____ mm	_____ mm
Stroke	_____ mm	_____ mm
Limiters (e)	_____ mm	_____ mm
Shock Stand Off	_____ mm	_____ mm

Notes _____