

# SET UP SHEET



Driver: Lee Martin Date: August 2023 Event/Track: TORCH - BRCA R6  
 Qualify: P5 Final: P3 Best Lap:

## TRACK TYPE

Grip Level High  Medium  Low   
 Type Tight  Open  Mixed   
 Condition Flat  Bumpy  Mixed   
 Surface Clay  Long Astro  Carpet   
 Grass  Short Astro  Mixed   
 Weather Dry

## TYRES

	FRONT	REAR
Tyres	Mezzo - Yellow	Mezzo - Yellow
Wheels	Schumacher	Schumacher
Inserts	Tubby	Tubby

Notes: 2.5 rows cut from outside & 2 rows cut from inside. Glued up the sidewall

## Notes:

Belt tension set loose.  
 Ti screw set - Tworks  
 Ti Turnbuckles  
 Fab set to medium

## FRONT SUSPENSION

KEY: P = Plastic, A = Alloy, B = Brass, CF = Carbon Fibre, S2 = Schumacher Composite, M = Medium, S = Stiff, Sh = Short, H = High, L = Low, F = Front, R = Rear, Y = Yes, N = No

Ride Height 17 mm  
 Wheelbase Long  Short   
 Toe 1 deg In  Out   
 Camber at Ride Height -2 deg  
 Anti Roll Bar None  1.2  1.4  1.6  1.8  1.9  2.0  2.1   
 Hub Height H  L   
 Bump Steer Washers 0 mm  
 Hingepin Height H  L   
 Driveshaft Type Roche  U/J   
 Steering Arm Kit  1 Dot  2 Dot  3 Dot   
 Track Narrow  Mid  Wide   
 Front Strap A  B

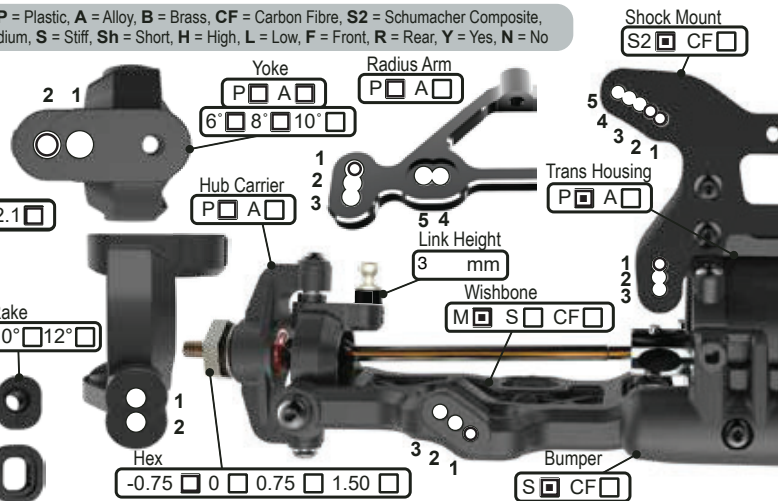

## REAR SUSPENSION

KEY: P = Plastic, A = Alloy, B = Brass, CF = Carbon Fibre, S2 = Schumacher Composite, M = Medium, S = Stiff, Sh = Short, H = High, L = Low, F = Front, R = Rear, Y = Yes, N = No

Ride Height 18 mm  
 Wheelbase Sh  M  L   
 Anti-Squat 1°  2°  3°  4°   
 Toe 4°  3.5°  3°  2.5°  2°  1.5°  1.0°  0.5°   
 Camber at Ride Height -2 deg  
 Anti Roll Bar None  1.2  1.4  1.6  1.8  1.9  2.0  2.1   
 Wing Gurney Height 5 mm  
 Driveshaft Type CVD  U/J   
 Gearbox Riser Y  N   
 Hub Height / Insert A  B  C  D  H  L   
 Pin Height H  L   
 High Pin Requires U8453

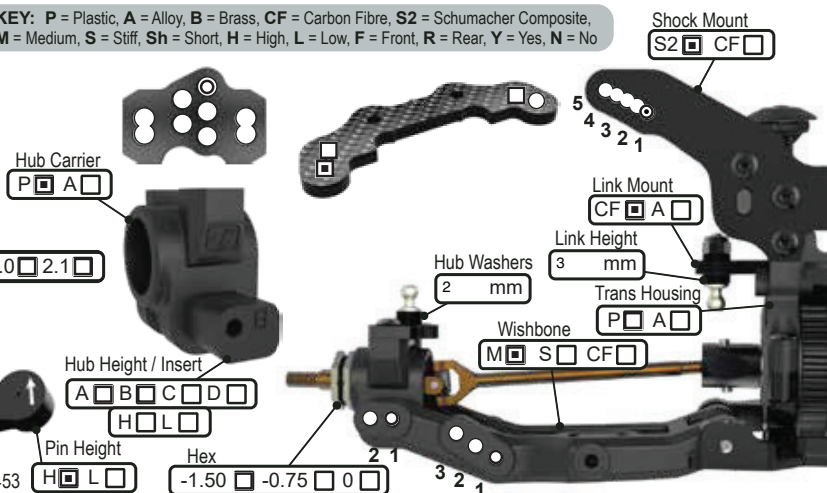

## CHASSIS

Chassis A  C/F   
 LiPo Position R  F   
 Running Weight 1650 g  
 Front Topdeck S2  CF

Motor Scorpion 5.5t  
 Rotor Dia. 12.3 mm  
 Timing 30 deg

Diff Height Front H  M  L  Diff Height Rear H  M  L   
 Diff Oil Front 15k cSt Diff Oil Rear 12k cSt  
 Diff Gears Front 2  4  Diff Gears Rear 2  4   
 Diff Body Front P  A  CF  Diff Body Rear P  A  CF

## WEIGHTS

Radio Tray Y  N   
 ESC Tray Y  N   
 Pinion 19 t  
 Spur t  
 R.O.S Y  N   
 Lock Out Y  N   
 Slipper Plates 2  3

## EQUIPMENT

E.S.C. Scorpion Vanguard  
 Servo Sanwa  
 RX Sanwa  
 LiPo NOSRAM 4200  
 Bodysell S2  
 Wing JC 7"

## TRANSMISSION

## SHOCKS

KEY: i = Internal, e = External, V = Vented, S = Sealed, A = Aeration

	FRONT	REAR
Cap	V <input type="checkbox"/> S <input type="checkbox"/> A <input type="checkbox"/>	V <input type="checkbox"/> S <input type="checkbox"/> A <input type="checkbox"/>
Kashima	Y <input type="checkbox"/> N <input type="checkbox"/>	Y <input type="checkbox"/> N <input type="checkbox"/>
Oil	575 cSt	475 cSt
Piston	1.8 x 2 taper	2.2 x 2 taper
Spring	Blue HR lb/in	Blue HR lb/in
Limiters (i)	2 mm	0 mm
Stroke	21 mm	28 mm
Limiters (e)	0 mm	oring mm
Shock Stand Off	3mm rear mm	

Notes:

