

Driver: Ben Smith Date: 9/9/23 Event/Track: RHR BRCA National RD5
 Qualify: Final: Best Lap:

TRACK TYPE

Grip Level High Medium Low
 Type Tight Open Mixed
 Condition Flat Bumpy Mixed
 Surface Clay Long Astro Carpet
 Grass Short Astro Mixed
 Weather

TYRES

	FRONT	REAR
Tyres	Mezzo	Mezzo
Wheels	Kit	Kit
Inserts	Tubby	Tubby

Notes:
 Front tyres with two outside rows cut off either side and glued sidewalls

Notes:
 LD2 rear hubs, hole 3

FRONT SUSPENSION

KEY: P = Plastic, A = Alloy, B = Brass, CF = Carbon Fibre, S2 = Schumacher Composite, M = Medium, S = Stiff, Sh = Short, H = High, L = Low, F = Front, R = Rear, Y = Yes, N = No

Ride Height 16 mm
 Wheelbase Long Short
 Toe 1 deg In Out
 Camber at Ride Height -1 deg
 Anti Roll Bar None 1.2 1.4 1.6 1.8 1.9 2.0 2.1
 Hub Height H L
 Bump Steer Washers 0 mm
 Hingepin Height H L
 Driveshaft Type Roche U/J
 Steering Arm Kit 1 Dot 2 Dot 3 Dot
 Track Narrow Mid Wide
 Front Strap A B

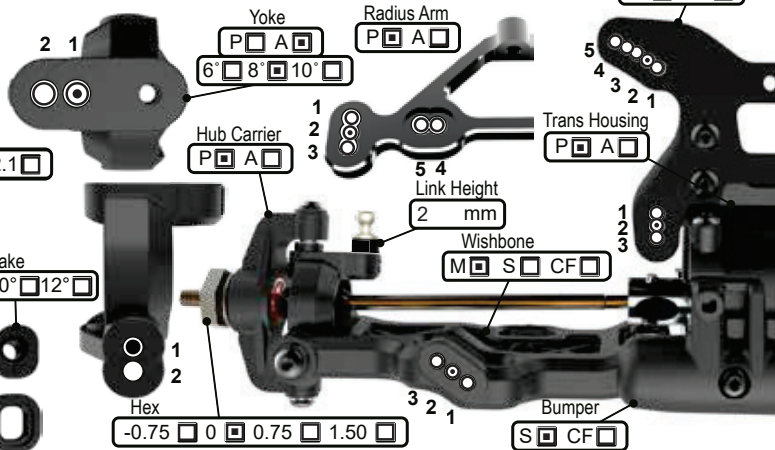

REAR SUSPENSION

KEY: P = Plastic, A = Alloy, B = Brass, CF = Carbon Fibre, S2 = Schumacher Composite, M = Medium, S = Stiff, Sh = Short, H = High, L = Low, F = Front, R = Rear, Y = Yes, N = No

Ride Height 16 mm
 Wheelbase Sh M L
 Anti-Squat 1 2 3 4
 Toe 4 3.5 3 2.5 2 1.5 1.0 0.5
 Camber at Ride Height -1 deg
 Anti Roll Bar None 1.2 1.4 1.6 1.8 1.9 2.0 2.1
 Wing Gurney Height mm
 Driveshaft Type CVD U/J
 Gearbox Riser Y N
 Hub Height / Insert A B C D
 Pin Height H L
 High Pin Requires U8453

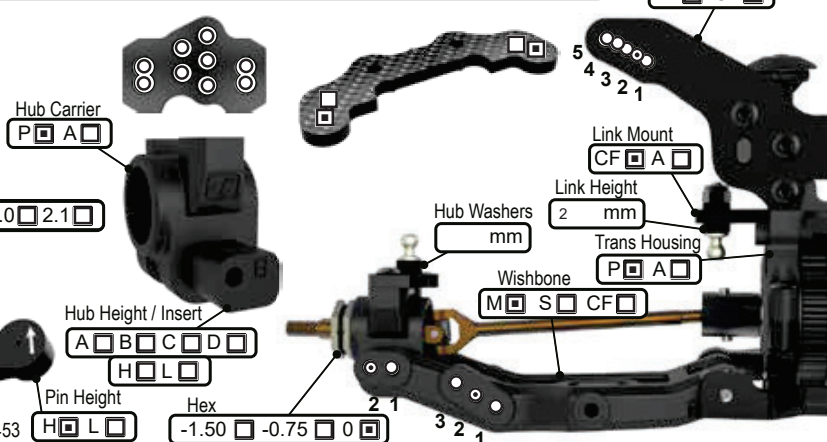

CHASSIS

Chassis A C/F
 LiPo Position R F
 Running Weight 9
 Front Topdeck S2 CF

Motor H/W 5.5t
 Rotor Dia. 12.3 mm
 Timing 40 deg

Diff Height Front H M L Diff Height Rear H M L
 Diff Oil Front 10k cSt Diff Oil Rear 10k cSt
 Diff Gears Front 2 4 Diff Gears Rear 2 4
 Diff Body Front P A CF Diff Body Rear P A CF

WEIGHTS

Radio Tray Y N
 ESC Tray Y N
 Pinion 22 t
 Spur Kit t
 R.O.S Y N
 Lock Out Y N
 Slipper Plates 2 3

EQUIPMENT

E.S.C. H/W XR10 Pro G2S
 Servo Highest D1000 Pro
 RX Sanwa RX492
 LiPo Intellect 4400
 Bodysell Jc S2
 Wing Jc 7"

TRANSMISSION

SHOCKS

KEY: i = Internal, e = External, V = Vented, S = Sealed, A = Aeration

	FRONT	REAR
Cap	V <input type="checkbox"/> S <input type="checkbox"/> A <input type="checkbox"/>	V <input type="checkbox"/> S <input type="checkbox"/> A <input type="checkbox"/>
Kashima	Y <input type="checkbox"/> N <input type="checkbox"/>	Y <input type="checkbox"/> N <input type="checkbox"/>
Oil	550 cSt	425 cSt
Piston	2 hole 1.8	2 hole 2.1
Spring	Black lb/in	Green HR lb/in
Limiters (i)	mm	mm
Stroke	22 mm	28 mm
Limiters (e)	mm	mm
Shock Stand Off	mm	mm

Notes:

