

Driver: *Allan O'Brien* Date: \_\_\_\_\_ Event/Track: *Grass starting setup*

Qualify: \_\_\_\_\_ Final: \_\_\_\_\_ Best Lap: \_\_\_\_\_

### TRACK TYPE

Grip Level High  Medium  Low

Layout Tight  Open  Mixed

Condition Flat  Bumpy

Surface Clay  Astroturf  Carpet   
Grass

Weather \_\_\_\_\_

### TYRES

FRONT REAR

Tyres *Schumacher Wide Stagger Yellow* / *Schumacher Yellow Minispiques*

Wheels *Kit* / *Kit*

Inserts *Schumacher blue med* / *Schumacher blue med*

Notes

Notes

*Run this when grass is thicker.*

*Kit front strap*

### FRONT SUSPENSION

KEY: P = Plastic, A = Alloy, B = Brass, CF = Carbon Fibre, S2 = Schumacher Composite, M = Medium, S = Stiff, Sh = Short, H = High, L = Low, F = Front, R = Rear, Y = Yes, N = No

Ride Height *20* mm

Wheelbase Long  Short

Toe *-1* deg In  Out

Camber at Ride Height *-2* deg

Anti Roll Bar None  1.2  1.4  1.6  1.8  1.9  2.0  2.1

Hub Height High  Low

Bump Steer Washers *Kit* mm

Hingepin Height High  Low

Driveshaft Type Roche  U/J

Steering Arm Kit  1 Dot  2 Dot  3 Dot

Track Narrow  Mid  Wide

Front Strap A  B

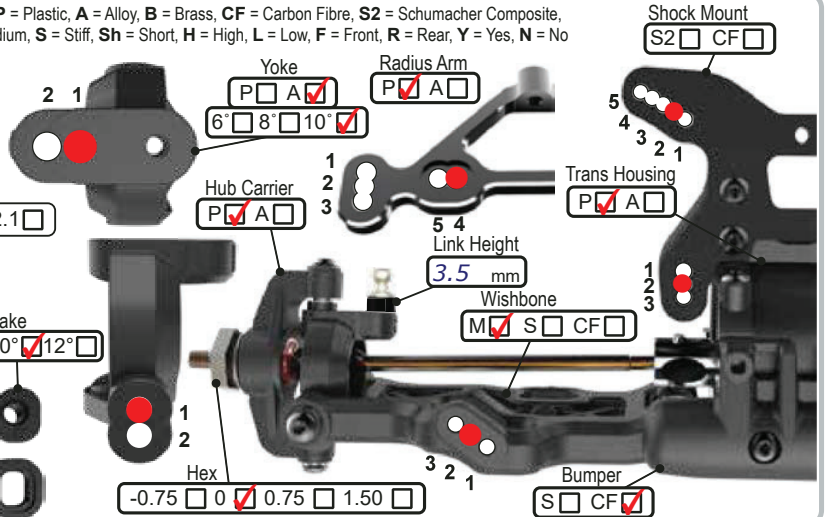

### REAR SUSPENSION

Ride Height *20* mm

Wheelbase Short  Medium  Long

Anti-Squat 1°  2°  3°  4°

Toe 4°  3.5°  3°  2.5°  2°  1.5°  1.0°  0.5°

Camber at Ride Height *-2* deg

Anti Roll Bar None  1.2  1.4  1.6  1.8  1.9  2.0  2.1

Wing Gurney Height \_\_\_\_\_ mm

Driveshaft Type CVD  U/J

Gearbox Riser Y  N

Hub Height / Insert A  B  C  D

H L

Pin Height High  Low

Hex -1.50  -0.75  0

High Pin Requires U8453

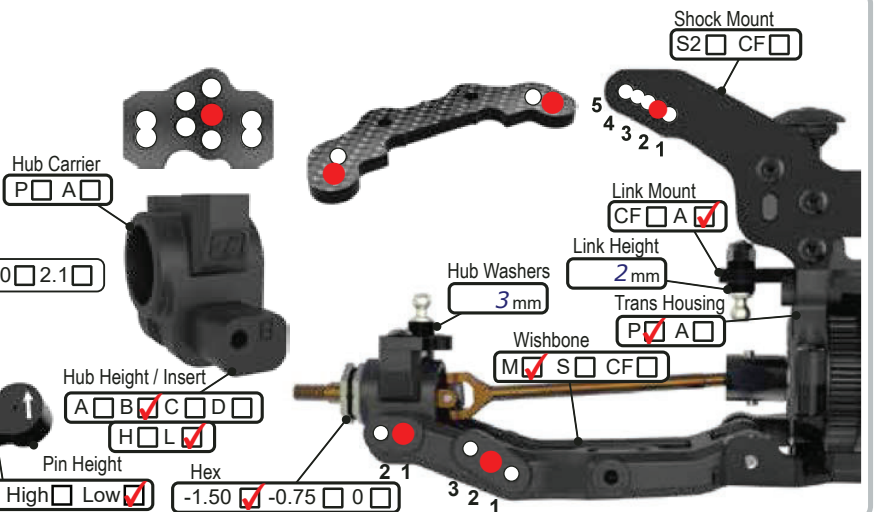

### CHASSIS

Chassis A  C/F

LiPo Position R  F

Running Weight *g*

Front Topdeck S2  CF

Motor \_\_\_\_\_

Rotor Dia. \_\_\_\_\_ mm

Timing \_\_\_\_\_ deg

### WEIGHTS

Radio Tray Y  N

ESC Tray Y  N

Pinion \_\_\_\_\_ t

Spur \_\_\_\_\_ t

R.O.S Y  N

Lock Out Y  N

Slipper Plates 2  3

### EQUIPMENT

E.S.C. \_\_\_\_\_

Servo \_\_\_\_\_

Receiver \_\_\_\_\_

LiPo \_\_\_\_\_

Bodyshell \_\_\_\_\_

Wing \_\_\_\_\_

### TRANSMISSION

Notes

Diff Height Front H  M  L  Diff Height Rear H  M  L

Diff Oil Front *12* cSt Diff Oil Rear *12* cSt

Diff Gears Front 2  4  Diff Gears Rear 2  4

Diff Body Front P  A  CF  Diff Body Rear P  A  CF

### SHOCKS

KEY: i = Internal, e = External, V = Vented, S = Sealed, A = Aeration

FRONT REAR

Cap V  S  A  V  S  A

Kashima Y  N  Y  N

Oil *450* cSt *350* cSt

Piston *2x1.8 (Red)* / *2x2.1 (Red)*

Spring *Blue Std* lb/in / *Red Std* lb/in

Limiters (i) \_\_\_\_\_ mm \_\_\_\_\_ mm

Stroke *22* mm / *28* mm

Limiters (e) \_\_\_\_\_ mm \_\_\_\_\_ mm

Shock Stand Off \_\_\_\_\_ 0 mm

Notes

