

Driver Details

Name wesley
 Date 11/2021
 Event / Track EIR Charleroi
 Weather indoor warm
 Result Q2 F1

Chassis and Electrics

Chassis Kit Flex
 Car Weight g
 Front Topdeck S2 2.0mm C/F 2.5mm C/F 3.0mm
 Rear Topdeck 2.5mm 3.0mm
 Sidepods S2 C/F
 Front Hex -0.75 0 0.75 1.5
 Rear Hex -0.75 0 0.75 1.5
 Bodysell pinguin Thickness .75 Rear Wing
 E.S.C maclan C/F Tray Brass Tray
 Servo dash
 Receiver sanwa C/F Tray Brass Tray
 LiPo TPPO LCG Front Middle Rear

Notes



Track Conditions

Grip Level High Medium Low
 Type Tight Open Mixed
 Surface Clay Astro Grass Mixed Carpet
 Condition Smooth Bumpy Mixed
 Jumps Small Medium Large Mixed

Wheels, Tyres and Inserts

Front Wheels schumacher Rear Wheels schumacher
 Front Tyres fusion yellow Rear Tyres cactus yellow
 Front Inserts medium Rear Inserts medium

Front Shocks

Spring Shock Cap Sealed
 Oil .550 cSt .orange lb/in Vented Aeration
 Piston .2 hole Drilled Hole Size .18 mm
 Internal Limiters mm Kashima Body No Yes

Front Diff

Height High Mid Low
 Oil 550 cSt 2 Gear 4 Gear
 Kit Alloy Carbon

Rear Diff

Height High Mid Low
 Oil 10 k cSt 2 Gear 4 Gear
 Kit Alloy Carbon

Motor and Gearing

Motor maclan 5.5
 Rotor Diameter 12.5
 Timing 30
 Spur Size kit
 Pinion Size 18

Other settings

Rear Wing Gurney Height 5mm
 Front Wing no Small Big
 Front Wing Gurney Height
 Slipper 2Plate 3Plate
Rear Shocks
 Oil .550 cSt black lb/in Shock Cap Vented Sealed Aeration
 Piston .2 hole Drilled Hole Size .18 mm
 Internal Limiters mm Kashima Body No Yes
 Shock Stand Off Spacing .2 mm

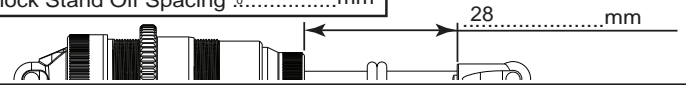
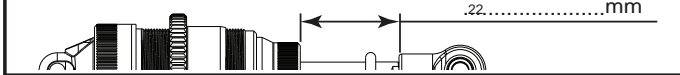
Front

Anti Roll Bar None 1.2 1.4 1.6 1.8 1.9 2.0 2.1
 Ride Height 14 mm
 Camber at Ride Height -2 Deg
 Toe +Z Deg
 Yoke 8° 10° 12°
 Yoke Med Stiff Alloy
 Bumper Stiff Carbon
 Link Washers 4 mm
 Wishbone Med Stiff Carbon
 Wheelbase Short Long
 Shock Mount C/F S2
 Hingepin Steel Ti
 Strap Alloy Brass
 Housing Kit Alloy
 Pin Angle 8° 10° 12°
 Pin Width Narrow Mid Wide
 Hub Spacer High Low
 Driveshaft Kit Roche
 Bump Steer Washers 1 mm

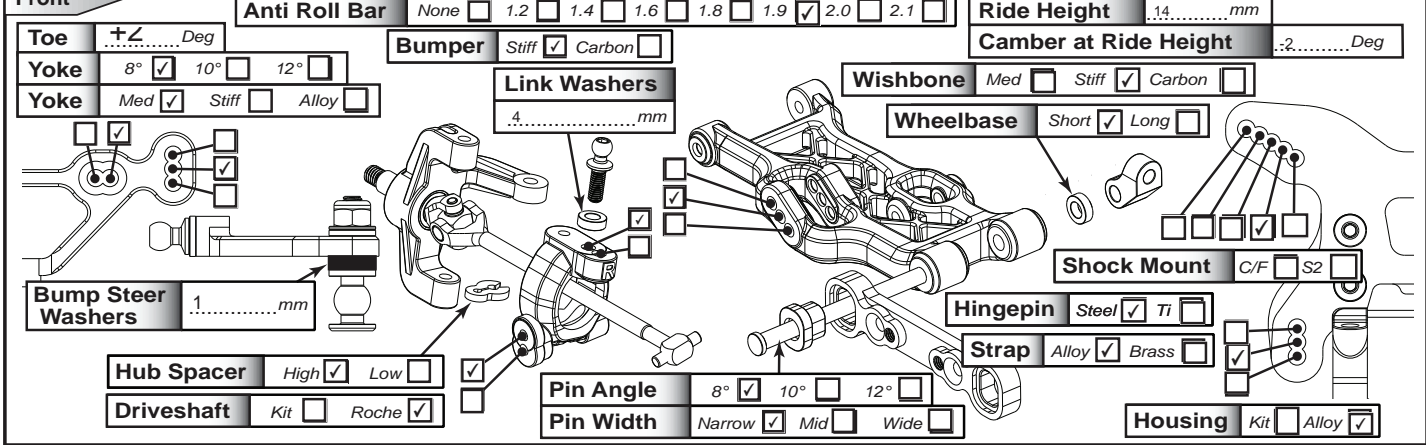

Rear

Anti Roll Bar None 1.2 1.3 1.4 1.6 1.8 1.9 2.0 2.1
 Shock Mount C/F S2
 Toe In 4° 3.5° 3° 2.5°
 2° 1.5° 1° 0.5°
 Ride Height 14 mm
 Camber at Ride Height -2 Deg
 Wheelbase Short Med Long
 Anti-squat 1° 2° 3° 4°
 Hub Washers mm
 Hub Carrier Kit Alloy
 Brass insert Hi-Pin Low-Pin
 Driveshaft UJ CVD
 Ball Stud Washer
 Link Washers .0 mm
 Housing Kit Alloy
 Rear Strap High Pin - Arrows up (U7977) Low Pin - Arrows down (Kit)
 Gearbox Riser Yes No
 Wishbone Med Stiff Carbon
 Hingepin Steel Ti
 Link Mount Kit Alloy

