

Driver & Event	
Name	Michal Orlowski
Date	6 August 2017
Event	Oople 2017, RHR, UK
Weather	Outdoor 22*C
Result	TQ&WIN

Electrics & Chassis	
E.S.C	LRP Flow 3.8
Servo	Sanwa SRG-BX
Reciever	Sanwa RX-481
Batteries	LRP Shorty 4200 LCG
Shorty Position	Front <input type="checkbox"/> Back <input type="checkbox"/>
Transverse Shorty	Yes <input type="checkbox"/> No <input type="checkbox"/>
Chassis Stiffeners	Yes <input type="checkbox"/> No <input checked="" type="checkbox"/>
Chassis	Alloy <input checked="" type="checkbox"/> Carbon <input type="checkbox"/>

Motor & Gearing	
Motor	LRP X20 6.5T
Rotor Diameter	12.5mm
Timing	27.5*
Spur	83
Pinion	22

Track Conditions	
Grip Level	High <input type="checkbox"/> Med <input checked="" type="checkbox"/> Low <input type="checkbox"/>
Type	Tight <input type="checkbox"/> Open <input type="checkbox"/> Mixed <input checked="" type="checkbox"/>
Surface	Clay <input type="checkbox"/> Astro <input checked="" type="checkbox"/> Grass <input type="checkbox"/> Mixed <input type="checkbox"/> Carpet <input type="checkbox"/>
Condition	Smooth <input type="checkbox"/> Bumpy <input checked="" type="checkbox"/>

Wheels & Tyres	
Rr Tyre	MiniSpike Yellow /U6558/
Rr Wheel	Schumacher hex /U4366/
Rr Insert	Medium /U6734/
Fr Tyre	Mini Dart Yellow /U6825/
Fr Wheel	Schumacher hex /U4496/
Fr Insert	Med. Front CAT /U6733/



Notes	
Car weight	g
Wing Gurney Height	low mm
<i>Rear roll bar 1.8; Fron roll bar 1.6 Front stiff wishbones, moved 2mm backwards 7.5 Degree rake. Short hub carriers U7002. Shorty across car, backwards 2.5mm rear topdeck. 2mm alloy chassis U4949 Alloy hubs U4998, high pin, middle ballstud position Wide rear suspension blocks U7139 Front tyres 2 spike rows outside and inside cut</i>	

Diff Type		Diff Oil
Front	Ball <input type="checkbox"/> Gear <input checked="" type="checkbox"/>	20 000
Rear	Ball <input type="checkbox"/> Gear <input checked="" type="checkbox"/>	10 000

Front Shocks		Spring	Shock Cap	Sealed
Oil	550	Yellow	Vented <input type="checkbox"/>	Emulsion <input checked="" type="checkbox"/>
Piston	SB 2x1.2	Drilled <input type="checkbox"/>	Hole Size	1.2 mm
		Shock Length		
		23.0 mm		

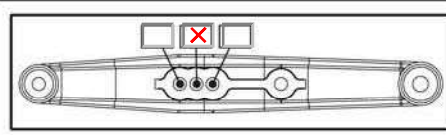
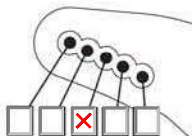
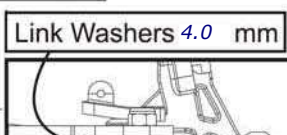
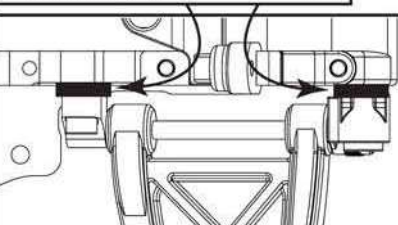
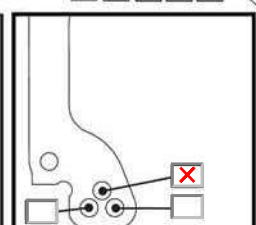
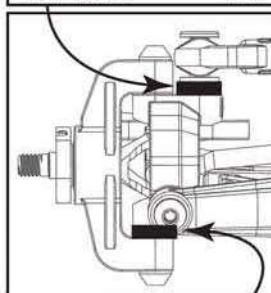
Rear Shocks		Spring	Shock Cap	Sealed
Oil	400	Green	Vented <input type="checkbox"/>	Emulsion <input checked="" type="checkbox"/>
Piston	SB 2x1.3	Drilled <input type="checkbox"/>	Hole Size	1.3 mm
		Shock Length		
		28.5 mm		

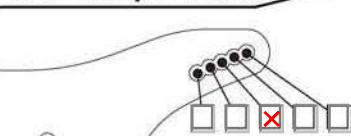
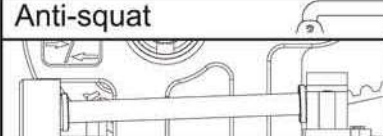
Front Suspension		Camber at Ride Height	1.0 Deg	Toe-In	- 0.5 Deg
Anti roll bar	No <input type="checkbox"/> 1.4 <input type="checkbox"/> 1.6 <input checked="" type="checkbox"/> 1.8 <input type="checkbox"/> 2.0 <input type="checkbox"/>	Ride Height	17.0 mm	Washers	3.0 mm
					
Track Washers R-0 F-1.0 mm		Link Washers 4.0 mm		Front Yoke 7.50 <input checked="" type="checkbox"/> (Kit) 10.0 <input type="checkbox"/>	
					
		C.T.R 17.0		Hub Spacer Above <input checked="" type="checkbox"/> Below <input type="checkbox"/>	

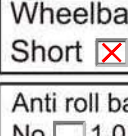
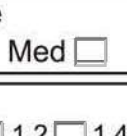
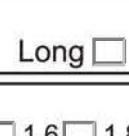
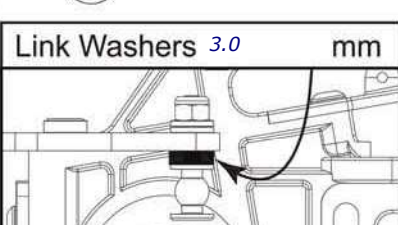
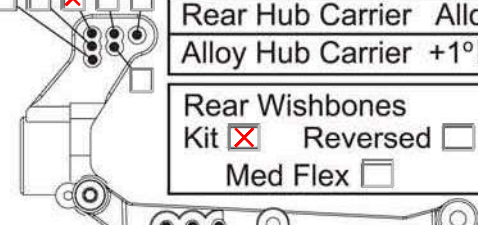
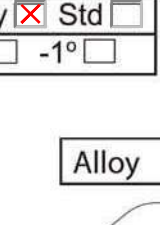
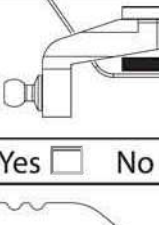
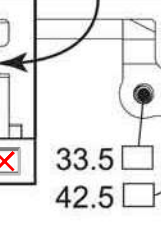
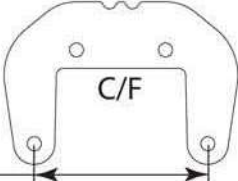
Rear Suspension		Anti-squat	0°	3°	1°	4°	2°	High Pin	Yes	No	Washers	3.0 mm
												
Link Washers 3.0 mm		Rear Hub Carrier Alloy <input checked="" type="checkbox"/> Std <input type="checkbox"/>		Alloy Hub Carrier +1° <input type="checkbox"/> -1° <input type="checkbox"/>		Rear Wishbones Kit <input checked="" type="checkbox"/> Reversed <input type="checkbox"/>		Med Flex <input type="checkbox"/>		Alloy Yes <input type="checkbox"/> No <input checked="" type="checkbox"/>		
												
Rear Ride Height 17.0 mm		<input checked="" type="checkbox"/> 33.5 (1 Dink) <input type="checkbox"/> 38.0 (2 Dink) <input type="checkbox"/> 42.5 (3 Dink)		C/F								
Rear Camber at Ride Height 1.0 Deg												
Rear Toe In (Flats IN 2.5°) <input type="checkbox"/> (Flats OUT 3.0°) <input checked="" type="checkbox"/>												

