

Driver & Event	
Name	
Date	
Event	
Weather	
Result	

Electrics & Chassis	
E.S.C	
Servo	
Receiver	
Batteries	
Shorty Position	Front <input type="checkbox"/> Back <input type="checkbox"/>
Transverse Shorty	Yes <input type="checkbox"/> No <input type="checkbox"/>
Chassis Stiffeners	Yes <input type="checkbox"/> No <input type="checkbox"/>
Chassis	Alloy <input type="checkbox"/> Carbon <input type="checkbox"/>

Motor & Gearing	
Motor	
Rotor Diameter	
Timing	
Spur	
Pinion	

Track Conditions	
Grip Level	High <input type="checkbox"/> Med <input type="checkbox"/> Low <input type="checkbox"/>
Type	Tight <input type="checkbox"/> Open <input type="checkbox"/> Mixed <input type="checkbox"/>
Surface	Clay <input type="checkbox"/> Astro <input type="checkbox"/> Grass <input type="checkbox"/> Mixed <input type="checkbox"/> Carpet <input type="checkbox"/>
Condition	Smooth <input type="checkbox"/> Bumpy <input type="checkbox"/>

Wheels & Tyres	
Rr Tyre	
Rr Wheel	
Rr Insert	
Fr Tyre	
Fr Wheel	
Fr Insert	

Notes	
Car weight	g
Wing Gurney Height	mm

Diff Type	
Diff Oil	
Front	Ball <input type="checkbox"/> Gear <input type="checkbox"/>
Rear	Ball <input type="checkbox"/> Gear <input type="checkbox"/>

Front Shocks	
Spring	Shock Cap Sealed <input type="checkbox"/>
Oil	Vented <input type="checkbox"/> Emulsion <input type="checkbox"/>
Piston	Drilled <input type="checkbox"/> Hole Size mm
 Shock Lengthmm	

Rear Shocks	
Spring	Shock Cap Sealed <input type="checkbox"/>
Oil	Vented <input type="checkbox"/> Emulsion <input type="checkbox"/>
Piston	Drilled <input type="checkbox"/> Hole Size mm
 Shock Lengthmm	

Front Suspension	
Anti roll bar	No <input type="checkbox"/> 1.4 <input type="checkbox"/> 1.6 <input type="checkbox"/> 1.8 <input type="checkbox"/> 2.0 <input type="checkbox"/>
Camber at Ride Height	Deg
Toe-In	Deg
Ride Height	mm
Washers	mm
Track Washers	mm
Link Washers	mm
C.T.R
Front Yoke	7.50 <input type="checkbox"/> (Kit) <input type="checkbox"/>
Hub Spacer	Above <input type="checkbox"/> Below <input type="checkbox"/>

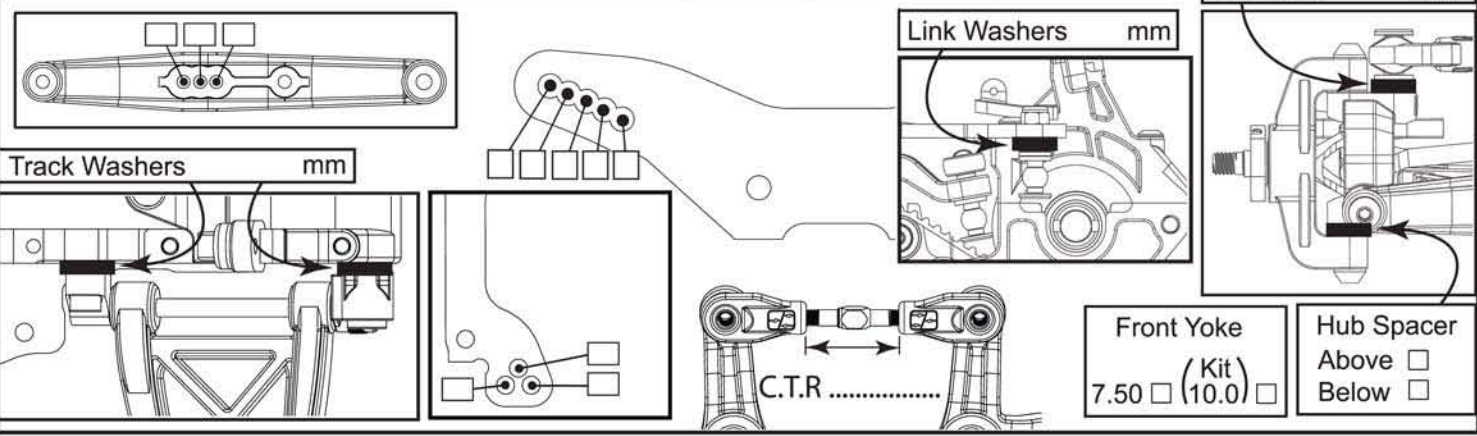

Rear Suspension	
Anti-squat	0° <input type="checkbox"/> 3° <input type="checkbox"/> 1° <input type="checkbox"/> 4° <input type="checkbox"/> 2° <input type="checkbox"/>
High Pin	Yes <input type="checkbox"/> No <input type="checkbox"/>
Wheelbase	Short <input type="checkbox"/> Med <input type="checkbox"/> Long <input type="checkbox"/>
Anti roll bar	No <input type="checkbox"/> 1.0 <input type="checkbox"/> 1.2 <input type="checkbox"/> 1.4 <input type="checkbox"/> 1.6 <input type="checkbox"/> 1.8 <input type="checkbox"/>
Link Washers	mm
Rear Hub Carrier	Alloy <input type="checkbox"/> Std <input type="checkbox"/>
Alloy Hub Carrier	+1° <input type="checkbox"/> -1° <input type="checkbox"/>
Rear Wishbones	Kit <input type="checkbox"/> Reversed <input type="checkbox"/>
Med Flex	<input type="checkbox"/>
Alloy	Yes <input type="checkbox"/> No <input type="checkbox"/>
Rear Ride Height	mm
Rear Camber at Ride Height	Deg
Rear Toe In (Flats IN 2.5°)	(Flats OUT 3.0°) <input type="checkbox"/>
33.5	<input type="checkbox"/>
38.0	<input type="checkbox"/> (2 Dink)
42.5	<input type="checkbox"/> (3 Dink)
C/F	

