



Driver and Event	
Name	
Date	
Event	
Weather	
Result	

Track Conditions	
Surface	
Grip Level	
Track Condition	

Wheels and Tyres	
Rear Wheels	
Rear Tyre	
Rear Insert	
Front Wheels	
Front Tyre	
Front Insert	

Diff Type	
Front	Ball <input type="checkbox"/> Gear <input type="checkbox"/>
Rear	Ball <input type="checkbox"/> Gear <input type="checkbox"/>

Additional Settings	
Car Weight	
Weights Added	
Chassis	Alloy <input type="checkbox"/> Option <input type="checkbox"/>

NOTES

Electrics and Gearing	
E.S.C	
Servo	
Receiver	
Batteries	
Motor	
Spur Gear	
Pinion	
LH Cell Position	Forward <input type="checkbox"/> Backward <input type="checkbox"/>

Rear Shocks	
Oil	Spring
Shock Cap Sealed <input type="checkbox"/>	Vented <input type="checkbox"/> Emulsion <input type="checkbox"/>
Piston	
Drilled <input type="checkbox"/>	Hole Size mm
	
Shock Length mm	

Front Shocks	
Oil	Spring
Shock Cap Sealed <input type="checkbox"/>	Vented <input type="checkbox"/> Emulsion <input type="checkbox"/>
Piston	
Drilled <input type="checkbox"/>	Hole Size mm
	
Shock Length mm	

Rear Suspension	
Anti roll bar	No <input type="checkbox"/> 1.00 <input type="checkbox"/> 1.20 <input type="checkbox"/> 1.40 <input type="checkbox"/> 1.60 <input type="checkbox"/>
Wheelbase	Short <input type="checkbox"/> Med <input type="checkbox"/> Long <input type="checkbox"/>

Camber at Ride Height	Deg
Ride Height	mm

Anti-squat Washers	
0.00 Difference = 0.00° Toe-in	<input type="checkbox"/>
0.50 Difference = 0.60° Toe-in	<input type="checkbox"/>
1.00 Difference = 1.30° Toe-in	<input type="checkbox"/>
1.50 Difference = 1.95° Toe-in	<input type="checkbox"/>
2.00 Difference = 2.60° Toe-in	<input type="checkbox"/>
2.50 Difference = 3.25° Toe-in	<input type="checkbox"/>
3.00 Difference = 3.90° Toe-in	<input type="checkbox"/>

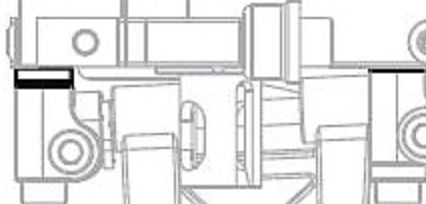
Rear Toe-in & Track Washers	
0.00 Difference = 0.00° Toe-in	<input type="checkbox"/>
0.50 Difference = 0.60° Toe-in	<input type="checkbox"/>
1.00 Difference = 1.30° Toe-in	<input type="checkbox"/>
1.50 Difference = 1.95° Toe-in	<input type="checkbox"/>
2.00 Difference = 2.60° Toe-in	<input type="checkbox"/>
2.50 Difference = 3.25° Toe-in	<input type="checkbox"/>
3.00 Difference = 3.90° Toe-in	<input type="checkbox"/>
Rear	mm
Front	mm
	
Blocks	Moulded <input type="checkbox"/> Alloy <input type="checkbox"/>

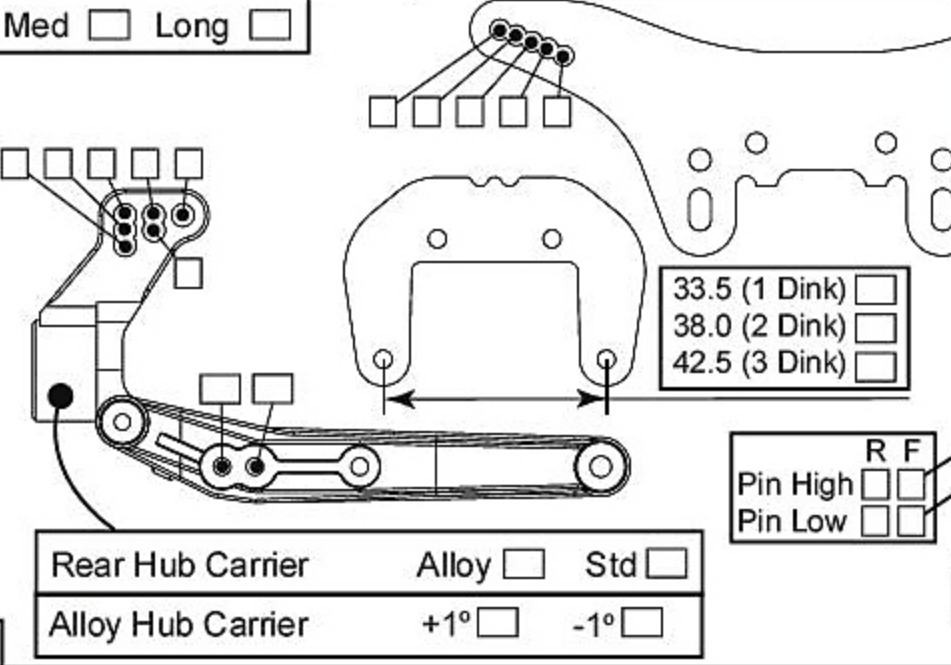

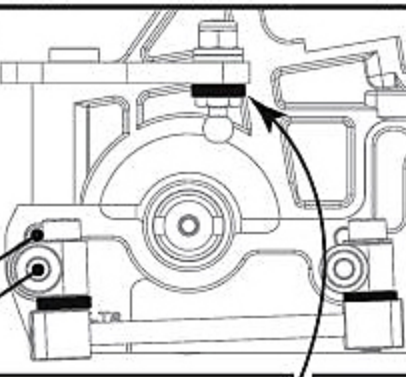
Rear	mm
Front	mm
	
Link Washers mm	

Front Suspension	
Anti roll bar	No <input type="checkbox"/> 1.00 <input type="checkbox"/> 1.20 <input type="checkbox"/> 1.40 <input type="checkbox"/> 1.60 <input type="checkbox"/>

Camber at Ride Height	Deg
Ride Height	mm

Toe-In	Deg
Washers	mm

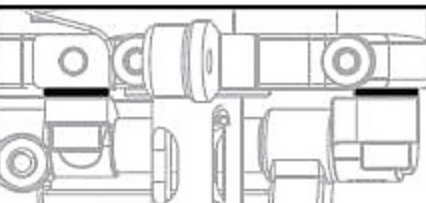
Track Washers	mm
	
Blocks	Moulded <input type="checkbox"/> Alloy <input type="checkbox"/>

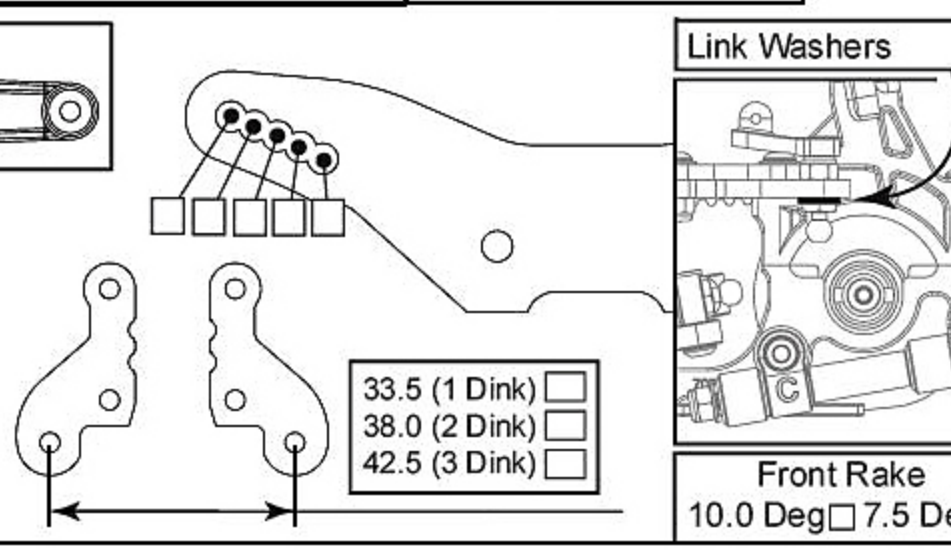

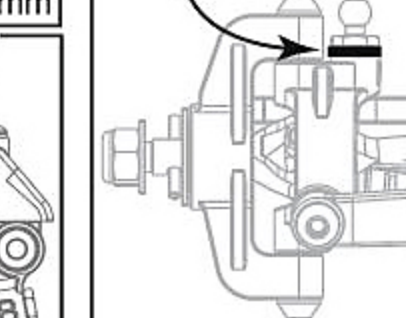
	
Front Yoke (Kit)	
12.5	<input type="checkbox"/>
10.0	<input type="checkbox"/>
7.5	<input type="checkbox"/>