

FRONT

Ride Height:	
Camber:	
Toe:	
Arm Stiffness:	Standard <input type="radio"/> Medium <input type="radio"/> Stiff <input type="radio"/>
Anti Roll Bar Thickness:	
Arm Mount Angle:	-2.5° <input type="radio"/> 0° <input type="radio"/> +2.5° <input type="radio"/>
C-Hub Arm Spacing - Fr:	mm - Rr mm
Axle Trail:	T3 <input type="radio"/> T4 <input type="radio"/>
C-Hub Caster Pill:	Plus <input type="radio"/> Minus <input type="radio"/>
	0 <input type="radio"/> 2 <input type="radio"/> 2.5 <input type="radio"/> 5 <input type="radio"/>
Steering Arms:	Aluminium <input type="radio"/> Plastic <input type="radio"/>

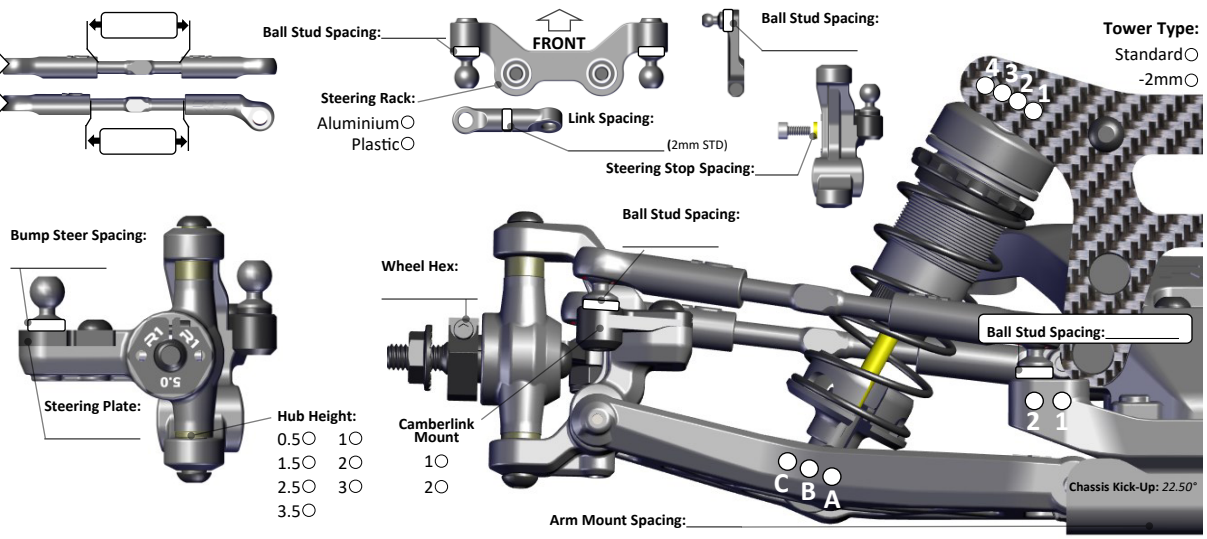

REAR

Ride Height:	
Camber:	
Arm Stiffness:	Standard <input type="radio"/> Medium <input type="radio"/> Stiff <input type="radio"/>
Anti Roll Bar Thickness:	
Arm Spacing:	Forward <input type="radio"/> Middle <input type="radio"/> Back <input type="radio"/>
Hub Spacing - Fr:	mm - Rr mm
Hub Type:	Std <input type="radio"/> HRC <input type="radio"/> Alum. <input type="radio"/> Plastic <input type="radio"/>
Tower Type:	Standard <input type="radio"/> -2mm <input type="radio"/>
Differential:	Ball <input type="radio"/> Gear <input type="radio"/>
Gear Diff Planet Gear Qty:	2Gear <input type="radio"/> 4Gear <input type="radio"/>
Differential Height:	Low <input type="radio"/> High <input type="radio"/>

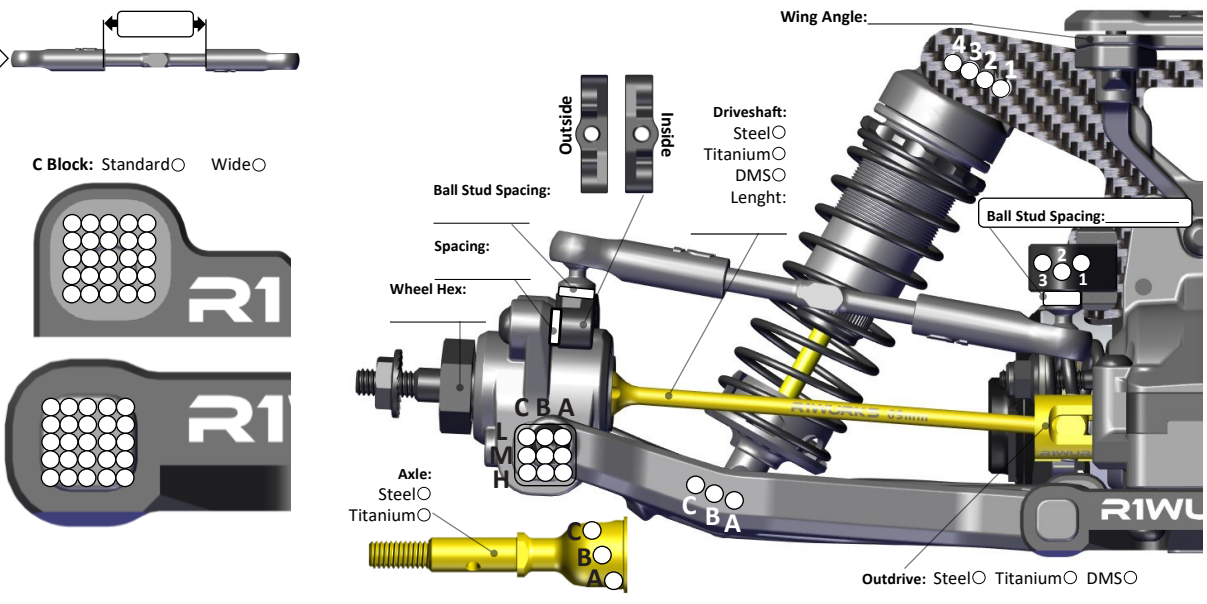

ELECTRONICS

Servo:	
ESC:	
Motor:	
Timing:	
Pinion:	Spur:
Battery:	Wt: g
Battery Position:	Inline <input type="radio"/> Transverse <input type="radio"/>
Inline Battery Position:	Fwd <input type="radio"/> Back <input type="radio"/>
Front [Transverse Battery Position] Rear	
Front [Inline Battery Position] Rear	
Fan:	Alum. <input type="radio"/> Plastic <input type="radio"/> Side <input type="radio"/> Cent. <input type="radio"/>

CHASSIS STIFFNESS

Rear Brace:	Yes <input type="radio"/> No <input type="radio"/>	Material:	Aluminium <input type="radio"/> Carbon <input type="radio"/>
Waterfall:	Yes <input type="radio"/> No <input type="radio"/>	Stiffness:	Standard <input type="radio"/> Medium <input type="radio"/> Stiff <input type="radio"/>
Waterfall Pivot:		Pivot:	Pivot <input type="radio"/> Solid <input type="radio"/>
Side Rail Stiffness:			Standard <input type="radio"/> Medium <input type="radio"/> Stiff <input type="radio"/>
Gearbox Stiffness:			Standard <input type="radio"/> Medium <input type="radio"/> Stiff <input type="radio"/>
Front Upper Chassis Brace Stiffness:			Standard <input type="radio"/> Medium <input type="radio"/> Stiff <input type="radio"/>
ESC Tray:	Steel <input type="radio"/> Brass <input type="radio"/> CFO <input type="radio"/>	Servo Tray:	Steel <input type="radio"/> Brass <input type="radio"/> CFO <input type="radio"/>
Rear Brace Screws			

SHOCKS

	FRONT		REAR	
Piston				
Thickness				
Oil Brand				
Oil				
Spring				
Limiters:	In:	Out:	In:	Out:
Stoke				
Eyelet				
Spring Cup				

GEAR TRAIN

Top Shaft:	Slipper <input type="radio"/> Lock-out <input type="radio"/>
Pad Material:	

TRACK

Name:	
Composition:	
Size:	
Traction:	
Surface:	
Weather:	

TIRES & WHEELS

Front- Tyre:	Rr:
Rear - Tyre:	Rr:
Compound - Fr:	Rr:
Foam - Fr:	Rr:
Tire Sauce:	
Front Sidewall Glue:	Inside <input type="radio"/> Outside <input type="radio"/>

BODY, WING & WEIGHT

Body:	
Rear Wing:	
Body Weight:	
Total Weight:	
Front-Rear Weight Bias - Fr	% - Rr: %

NOTES