

PR SB401

1/10 ELECTRIC 4WD OFF ROAD BUGGY

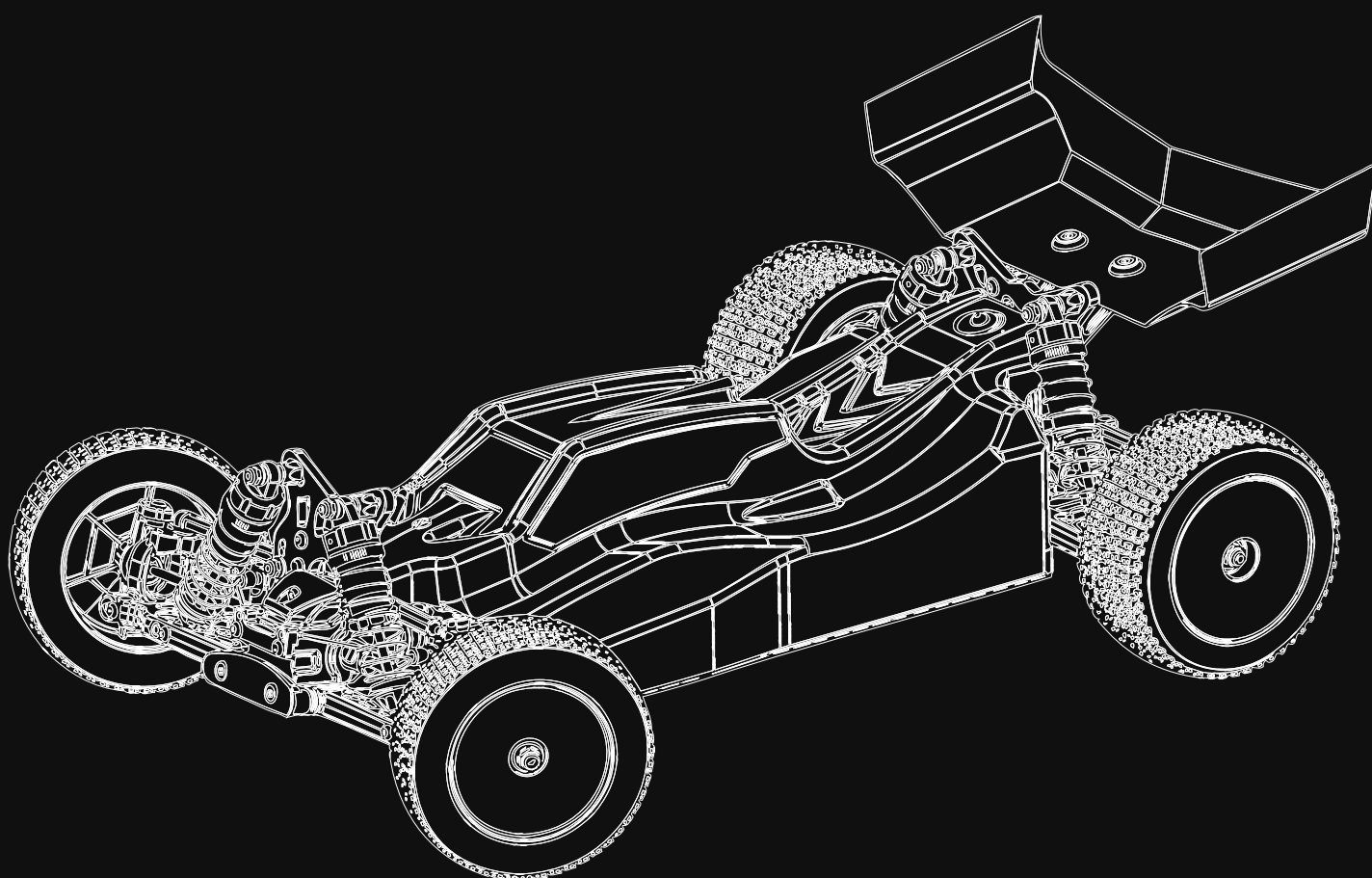

WARNING!

Thank you for purchasing this PR product. This kit is not a toy! It will require periodic maintenance & effort to keep it in top running condition. There are many extremely dangerous moving parts, such as the metal gears, motors and etc. Coming in contact with these during operation of the car may cause serious injury! Always check your radio operation system before running the car. Always switch off the car first before turning off the radio to avoid losing control. Safe operation will ensure great fun and enjoyment.

PR Racing SB401 1/10 Electric 4WD Off Road Buggy

PR Racing introduces the SB401 10th scale Competition off road Buggy Pro Kit. Front suspension is equipped advanced steering block and upright to improve steering reaction and fluency, carbon fiber front and rear shock tower plate provide durability and suspension rigidity. Kit contains strengthened parts and various allocation to achieve the biggest track applicability.

This all new off road Buggy comes with Weight bias changeable design, by using either the front motor configuration with a saddle pack or the rear motor configuration with a shorty pack(All parts in one Kit). This allows the SB401 extremely adaptable to any track condition.

PR Racing' s shock absorber always comes with quality and good design. With a bore of 12.75mm the PR Racing Shocks is the biggest competition level shocks in the market at this time.

Rear shock can be set to two location(in front of rear sus-arm or at rear).

With different setting, rear shock will provide enhanced driving sense and stability. This function also allows the vehicle to soak up a wide variety for terrains and track surfaces without losing speed. PR Racing offers a wide range (4 variations) of shock pistons, these allow drivers to fine tune the damping of the vehicle according track condition.

SB401 is equipped CNC bevel & drive pinion gear(39T/15T) both in front and rear differential, those CNC gears are durable, heavy duty and works well. Differential Gear Case whether in front or rear end, can be disassembled quickly and easy to maintain or change.

Quality can be found throughout in the SB401 kit. All parts in the kits is made from composites or aluminum materials. The SB401 Chassis is produced with high grade CNC Hard anodized aluminum.

If you' re looking for a competitive and very versatile 10th scale 4wd off road Buggy, then look no further than the PR Racing SB401 4wd off road Buggy.



Deploy

在馬達擺設方式,可以選擇前置與後置兩種。

The way of Motor furnishings, you can choose in two ways(Front&Rear).

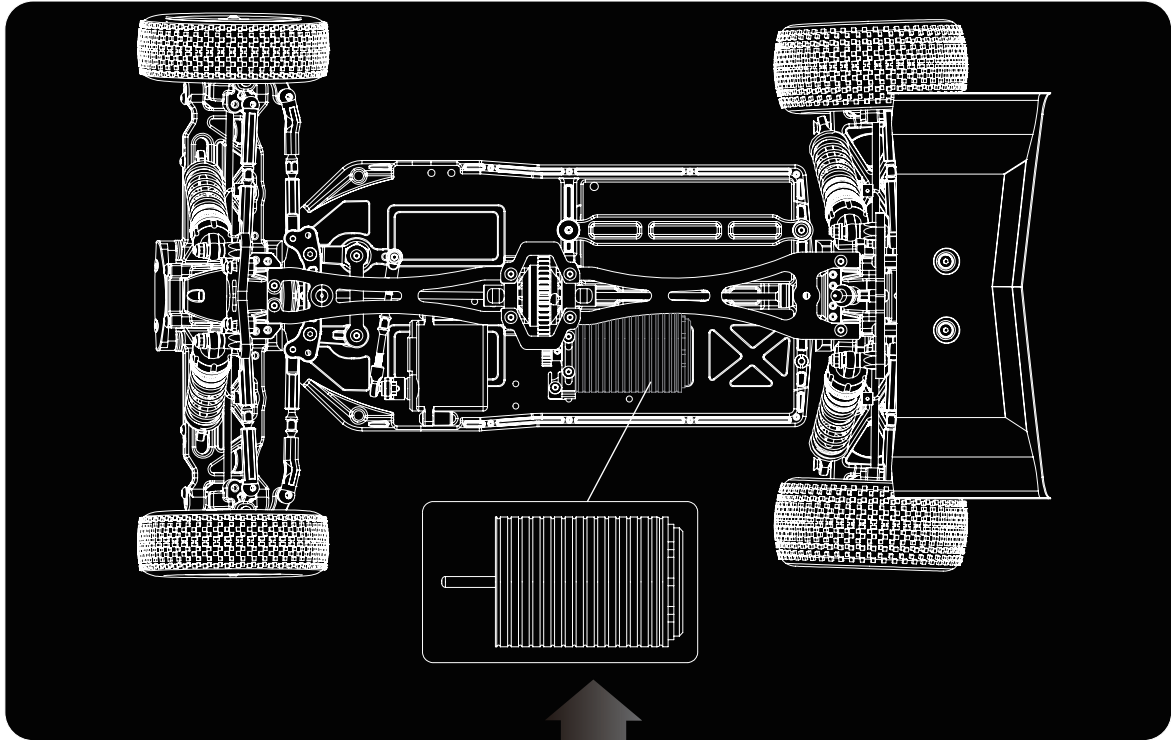

OR

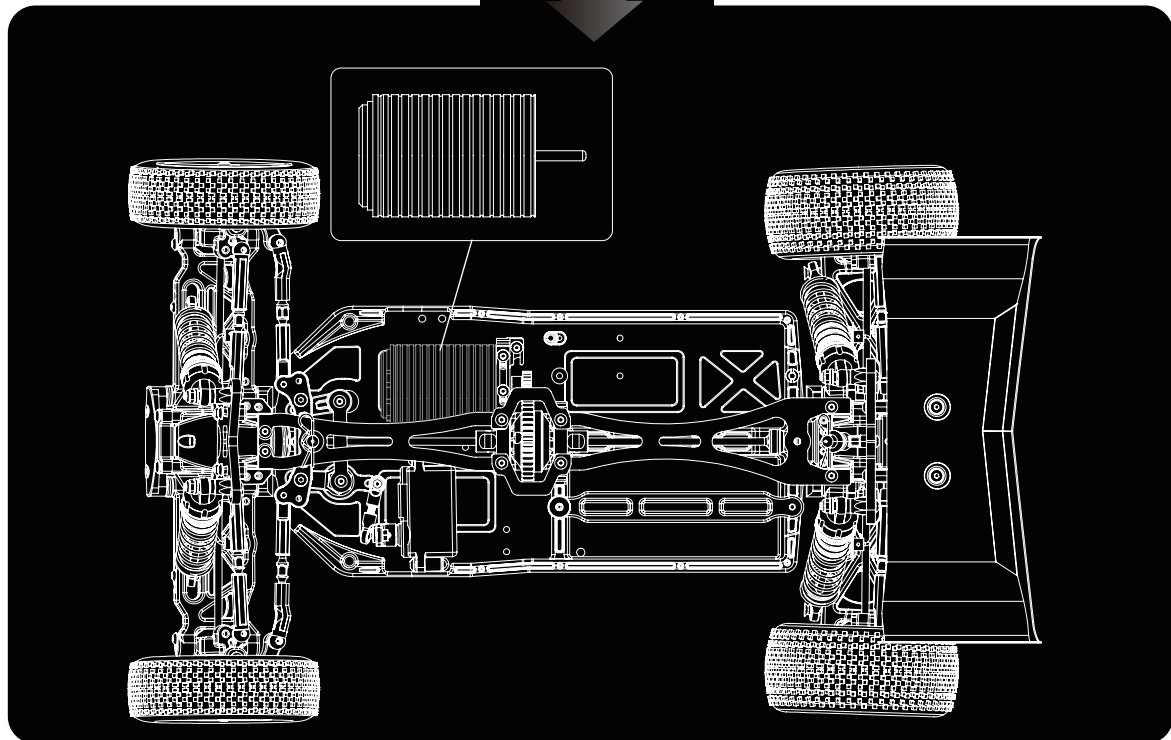



Deploy

在中置傳動系統可選擇紐線與齒輪差速兩種
(選擇紐線傳動要另外購買)

In Mid Drivetrain system can choose Differential and Gear Diff two ways.
(It will cost extra if ones choose differential drivetrain.)

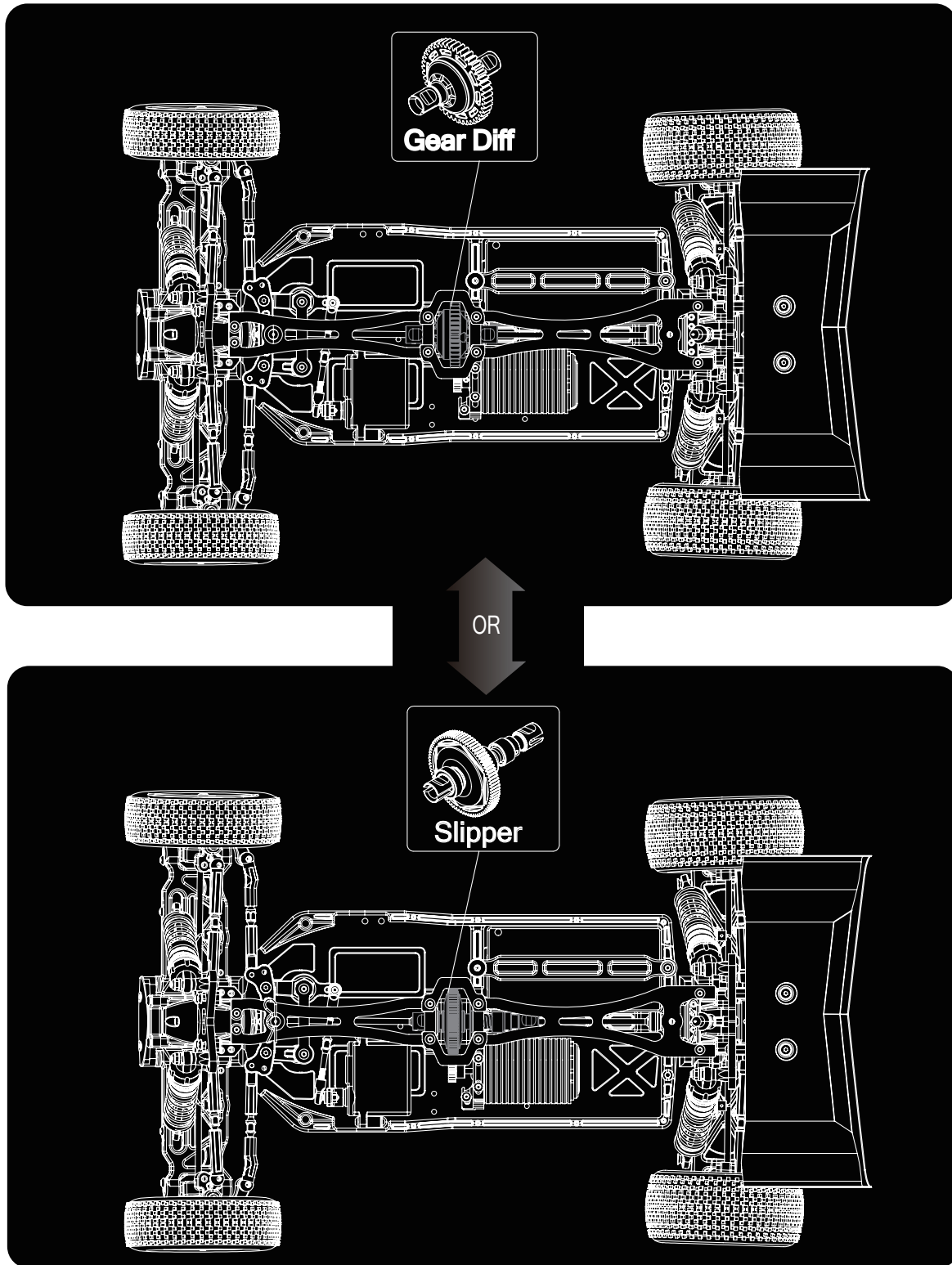



Deploy

在伺服機擺設方式,可選擇左邊與右邊。

The way of Servo furnishings, you can choose left & right.

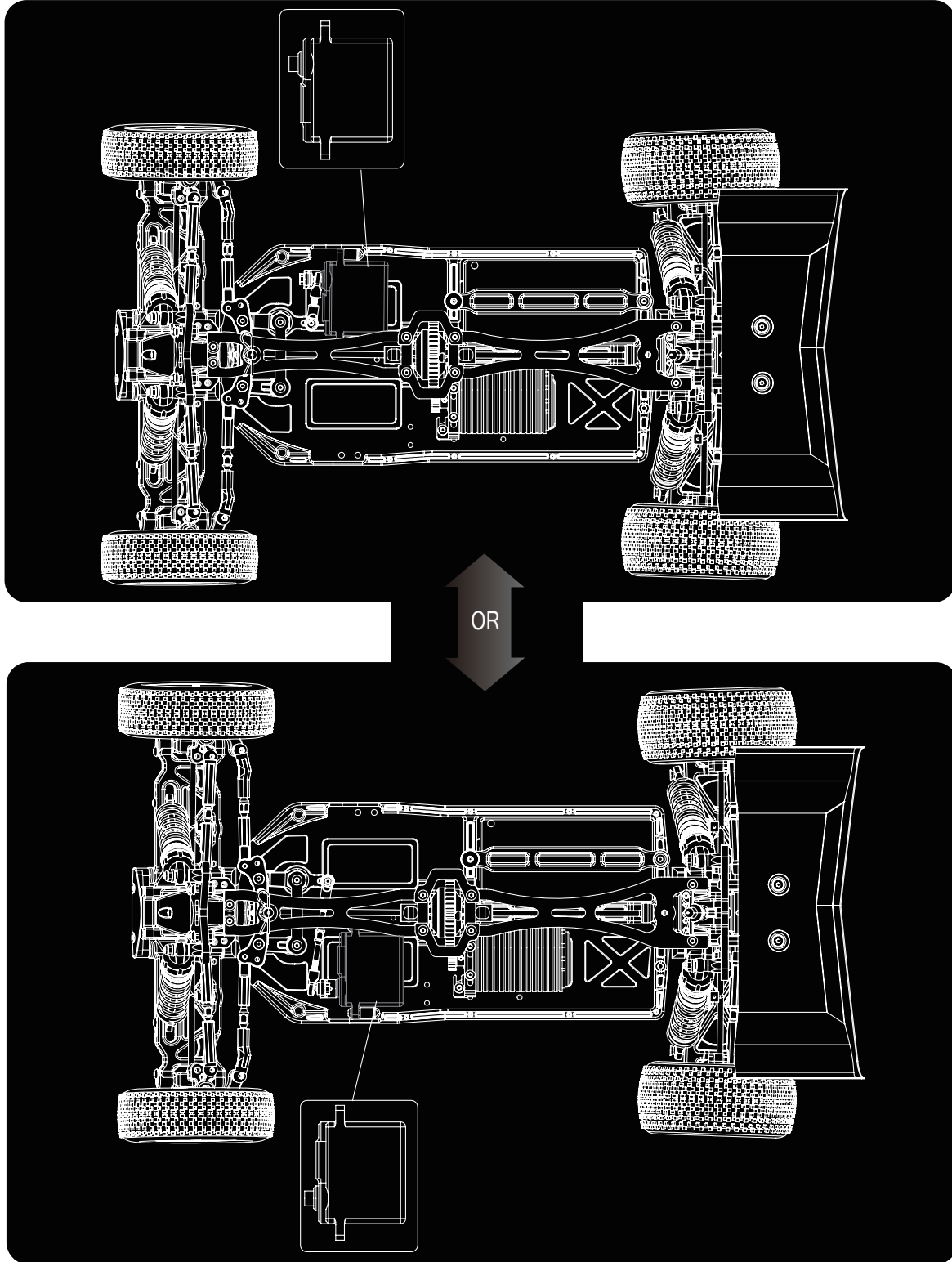



Deploy

在後避震器的擺設位置,因應不同場地特性,可選擇擺設置前方與後方。
(如選擇後方,尾翼必須裁剪)

The Rear suspension's furnishings place, with different features of place,
can choose to put Front & Rear. (If you choose Rear, wings have to be cut.)

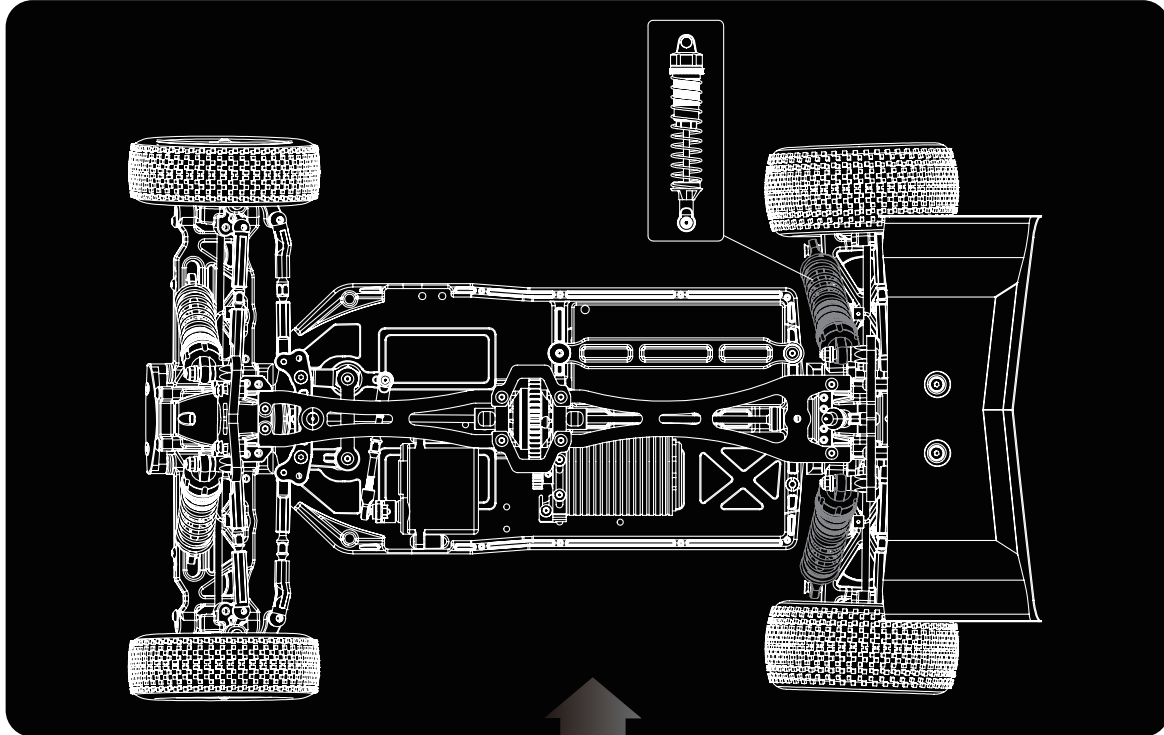

OR

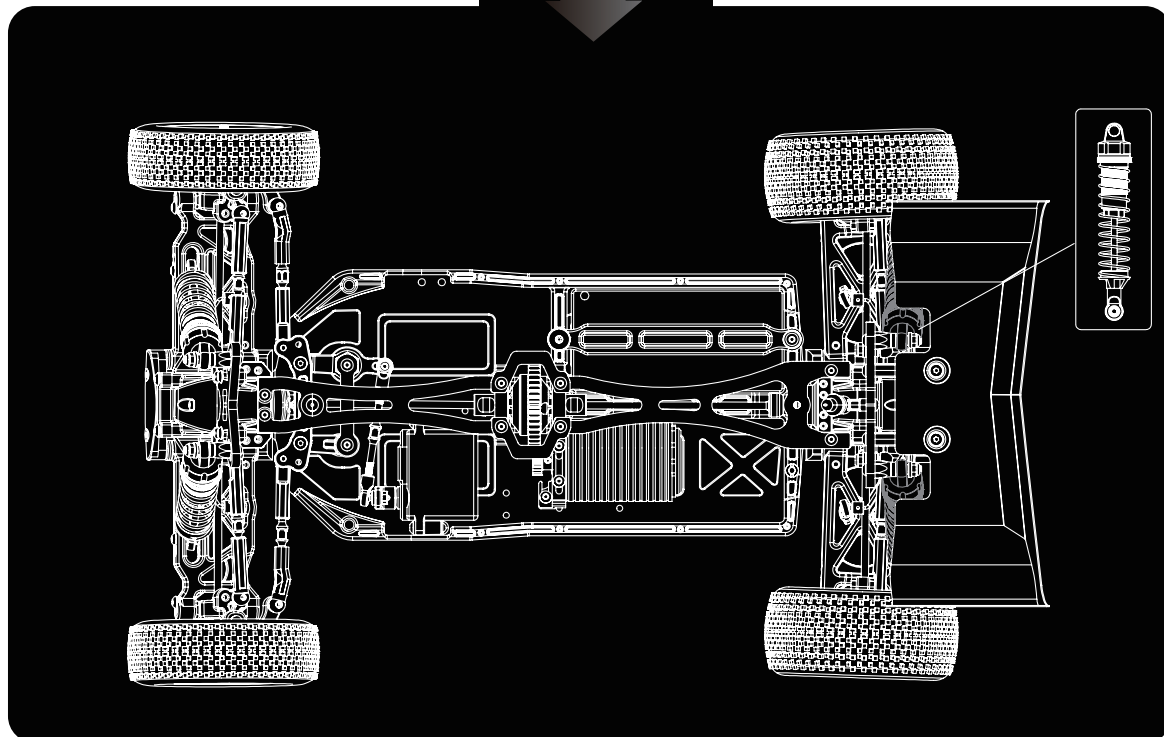



Deploy

在六角輪座可選擇12mm或14mm。

In Hexagonal Wheel Stand, can choose 12mm or 14mm.

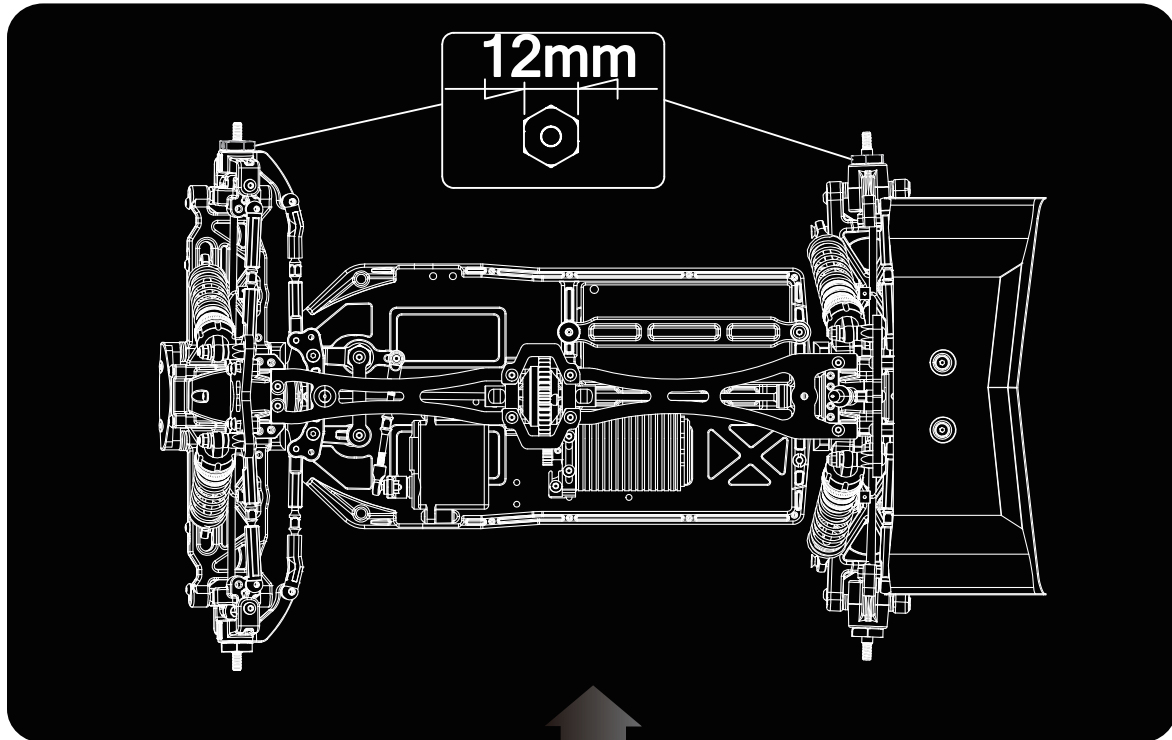

OR

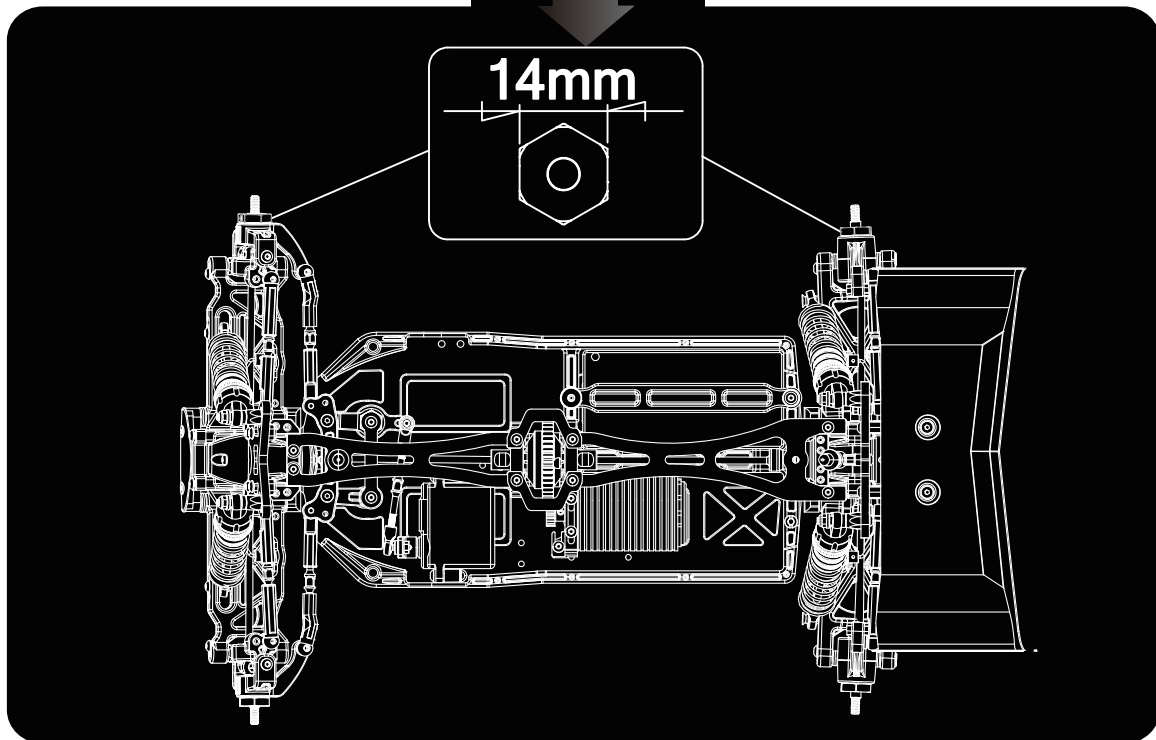

● BEFORE INSTALLATION -----	01
● BAG A -----	04-10
Chassis Guard Installation	
Front&Rear Differential	
Center Diff	
Front Central Transmission	
Rear Central Transmission	
● BAG B -----	11-14
Front Assembly	
Front Spindle(Left Side)	
Front Spindle(Right Side)	
Front Suspension	
● BAG C -----	15-17
Rear Assembly	
RearSuspension	
● BAG D -----	18-23
Steering	
Steering Servo	
Body Mounts	
Gear Piff Assembly	
Top Deck Buid	
● BAG E -----	24-30
Shock Assembly	
Shock Spring	
Front Suspension	
Rear Suspension	
Motor	
Battery Cradle	
Wheels	
Body Mounting	
Body Shell	
● SETUP SHEET -----	31
● EXPLOSION PICTURE -----	32
● SPARE PARTS &OPTIONAL PARTS -----	33-36

BEFORE INSTALLATION

- 1 Read through the instruction manual before installation in order to have an overview of what to do.
- 2 Check if there is any missing bags or defective parts, if there is, please contact our local dealer or our PR Distributor.
- 3 Symbols used throughout the instruction manual, comprises of:



Part bags used.



Assemble as many times as specified (here: twice).



Tighten securely.



Note the direction.



True-to-scale diagram.



Do not over tighten.



Must be purchased separately.



Apply threadlocker (screw cement)



Ensure smooth non-binding movement while assembling.



Assemble in the specified order.



Apply grease.



Cut off shaded portion.



Assemble left and right sides the same way.



Apply oil.

- 4 This kit contains screws and hardware in different metric sizes and shapes. Before using them, check the screws on the true-to-scale diagrams on the left side in each assembly step. Some screw are extras.

TOOLS REQUIRED

CAUTION: Handle tools carefully!

- Needle Nose Pliers

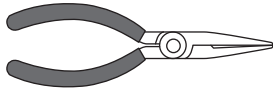

- Awl

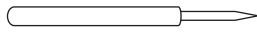

- Grease



- Screw Cement



- Round Cutter & Sander

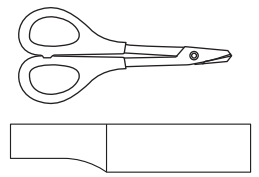

- Sharp Hobby Knife

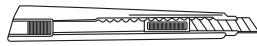

- Wire Cutters



For trimming bodies Cutting along curved lines was never so easy!

- Hex Wrench

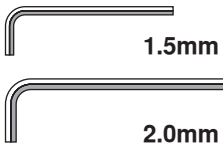

- Ball Differential Grease



- SP Knife Edge Reamer

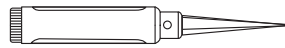

- Cross Wrench

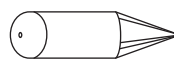
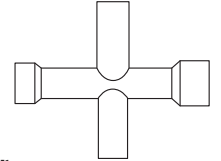

Do not pre-drill as precise drilling of 1mm to 15mm holes can be performed after body shell painted.

RADIO PREPARATION

- A new battery must be charged before it is used. Refer to the charger instruction manual for charging.
- Set up the radio control system as indicated below.

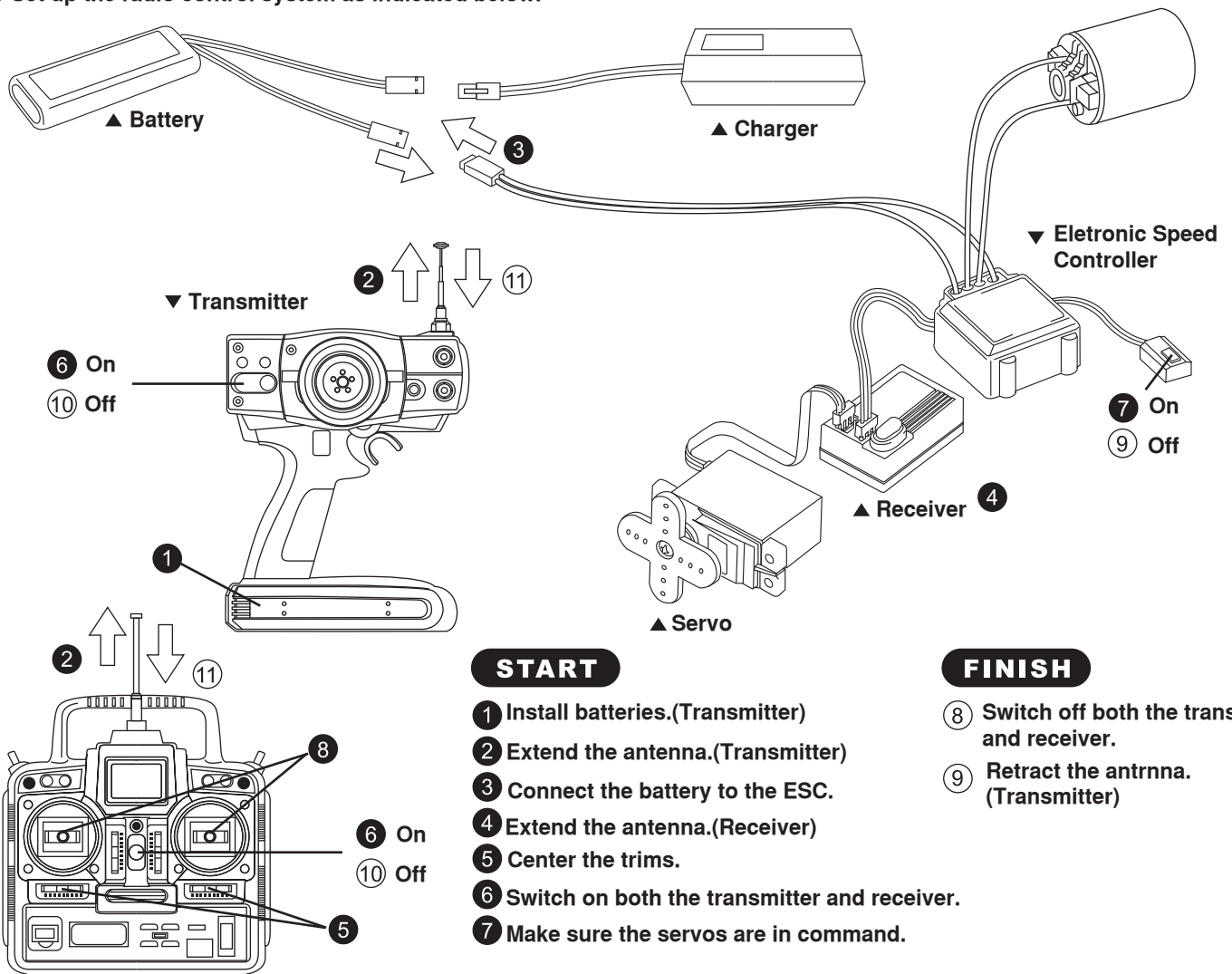



Deploy

在組裝前,請先選擇好電池種類(短版電池/分置電池),將會影響組裝方式。

Before assembling, please choose the battery type(Shorty battery/Saddle battery), it will impact the assemble way!!

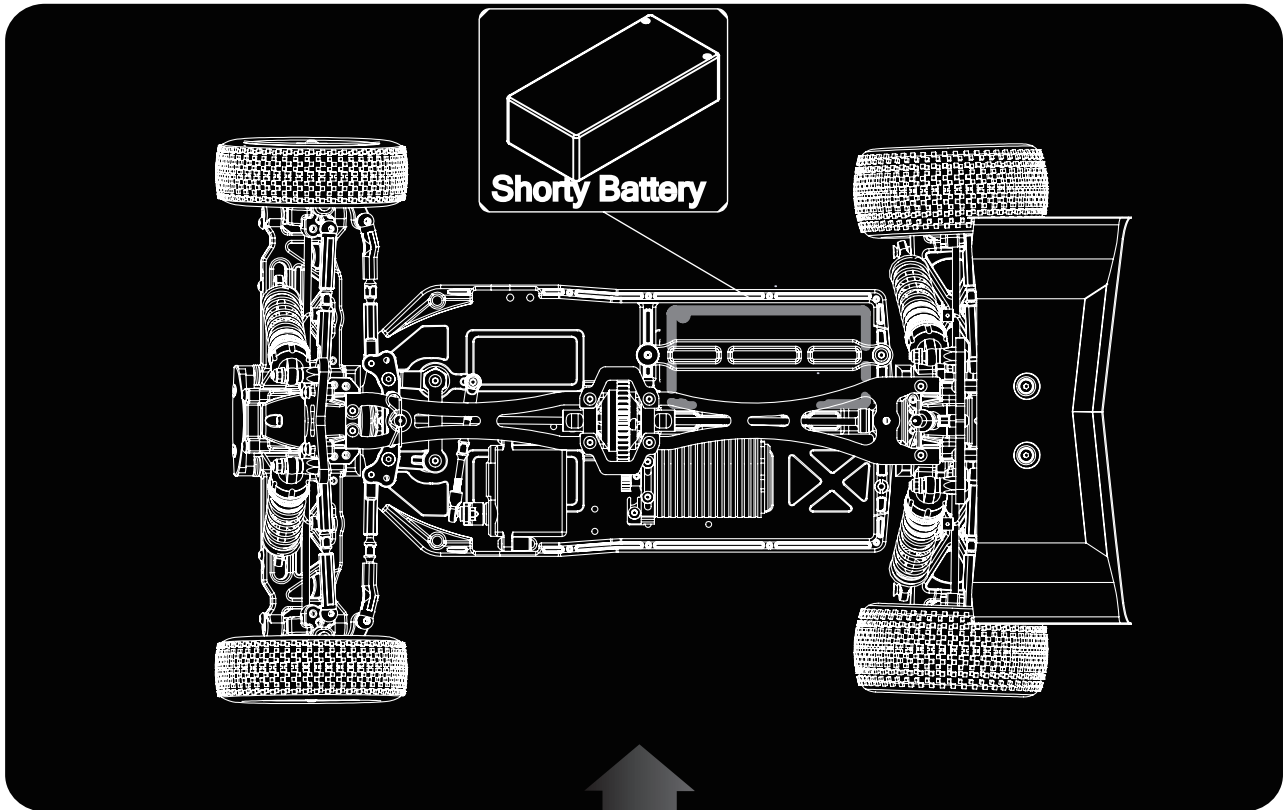

OR

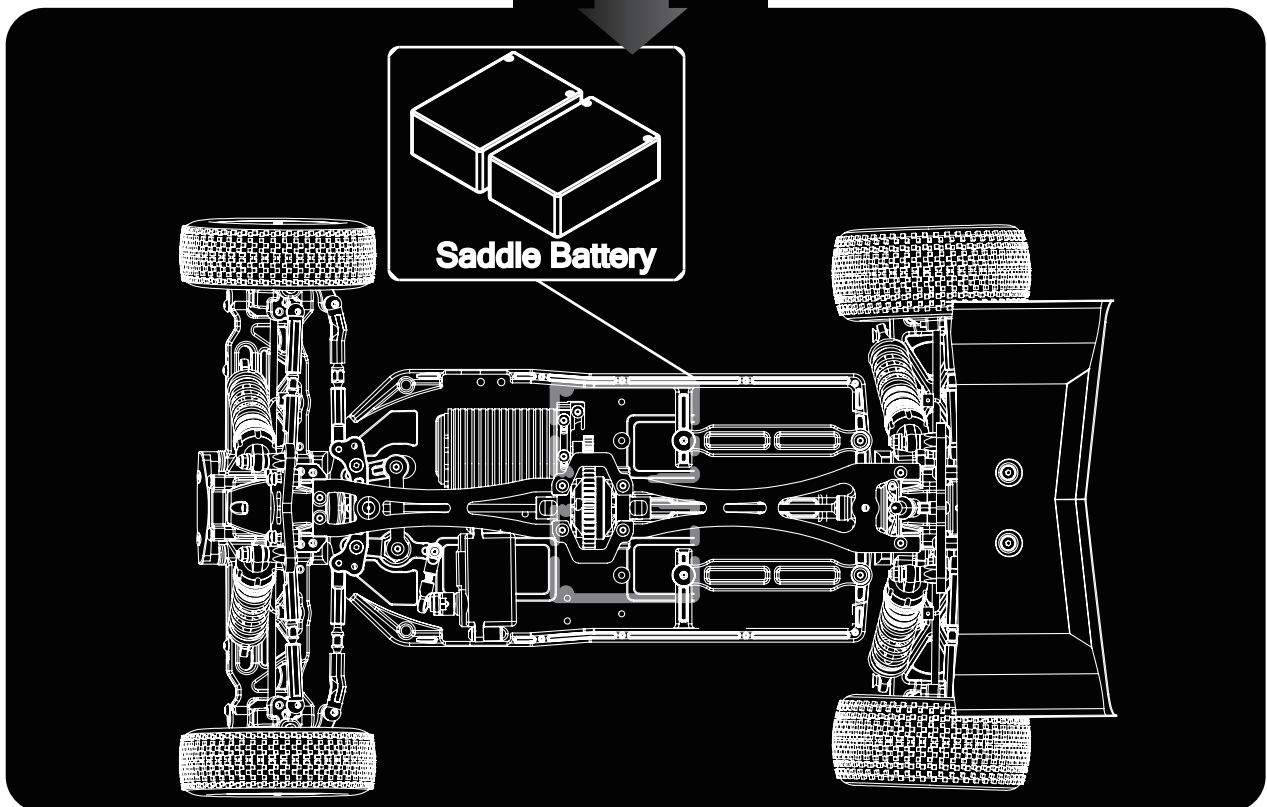



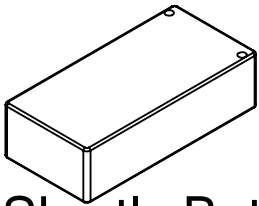

BAG
A

A1 Side Plate



Shortly Battery

-  12
M2.6X6mm Flat Head Hex Screw
-  2
M3X6mm Flat Head Hex Screw

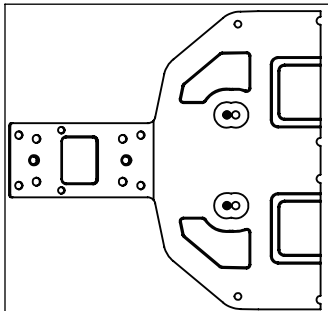

68400056

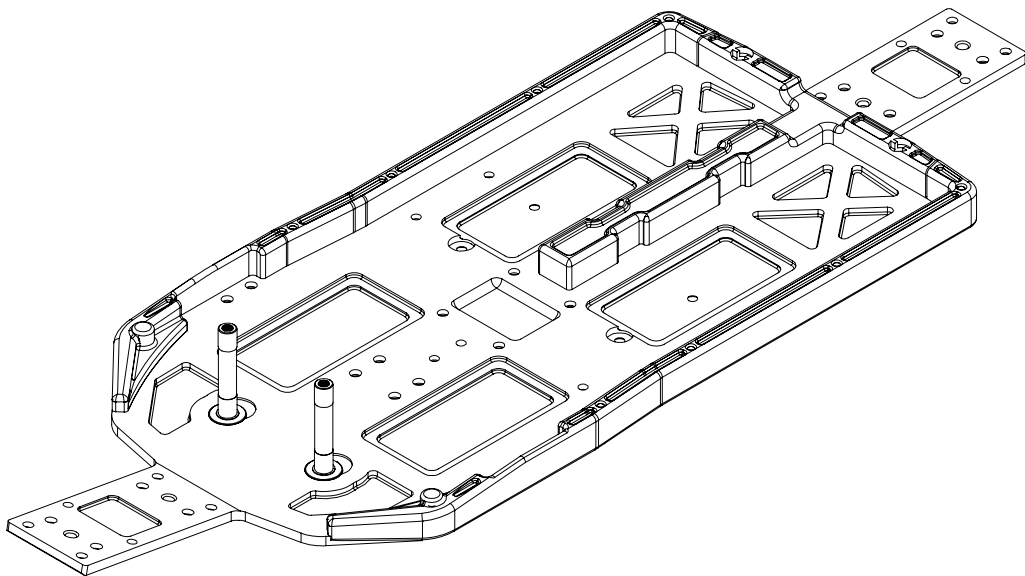
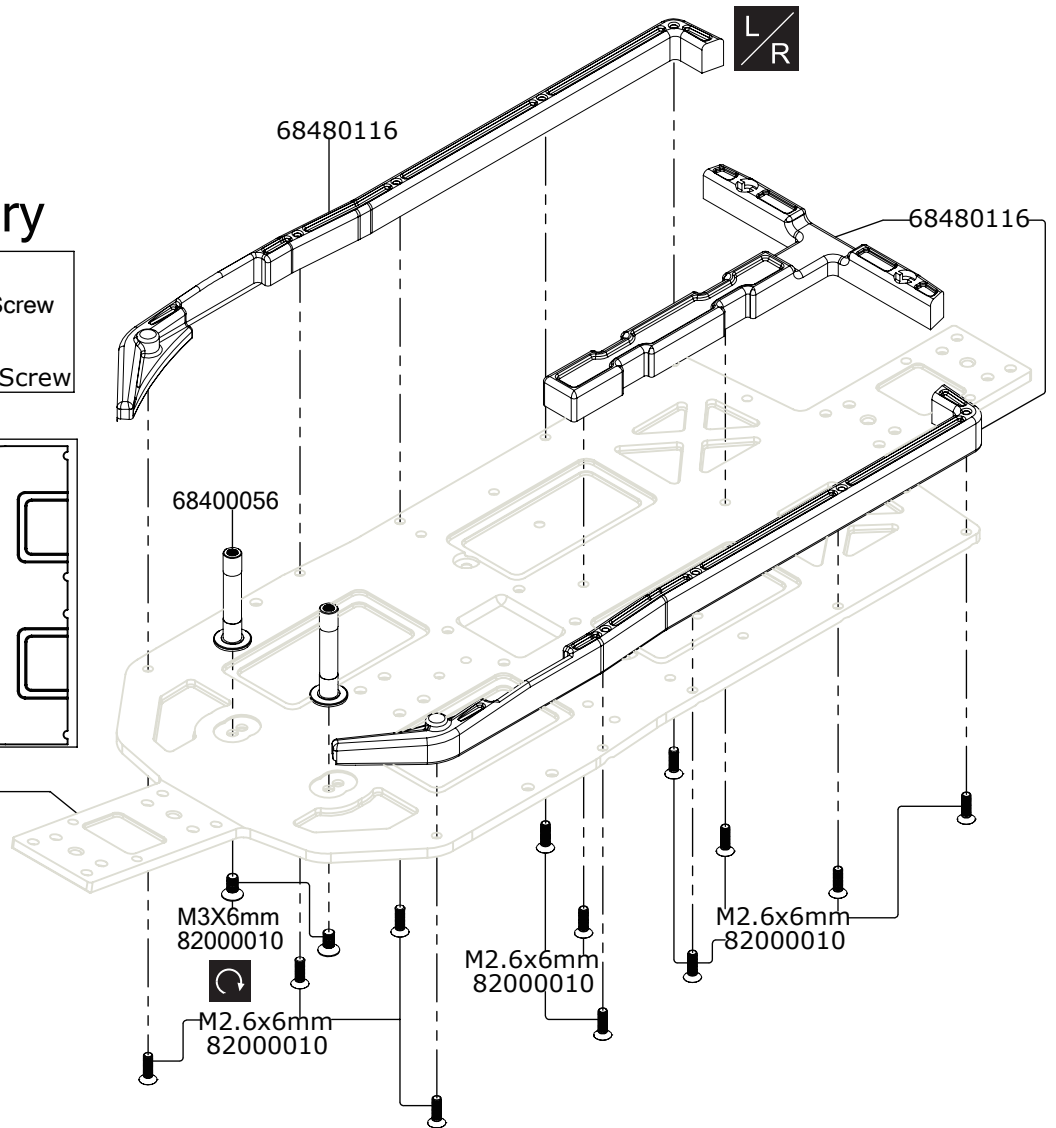

Part Bags used.



Tighten securely.







Assemble left and right sides the same way.



BAG A

A2 Front&Rear Differential

-  4
M2.6X8mm Flat Head Hex Screw
-  4
5X8x0.8mm Washer
-  8
4X10x0.15mm Washer
-  8
4X8x0.25mm Washer

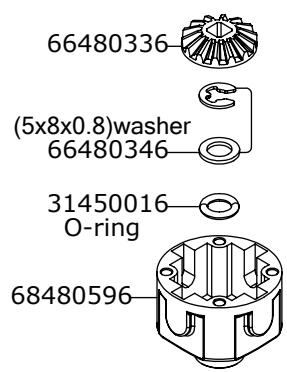
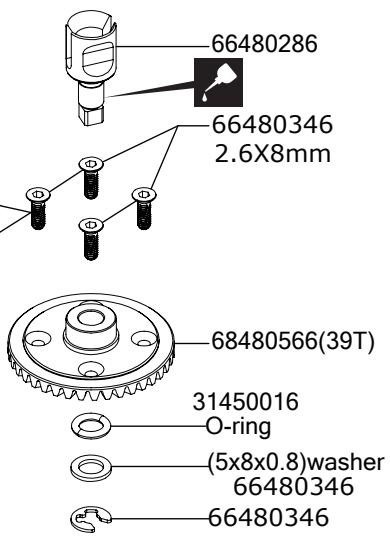
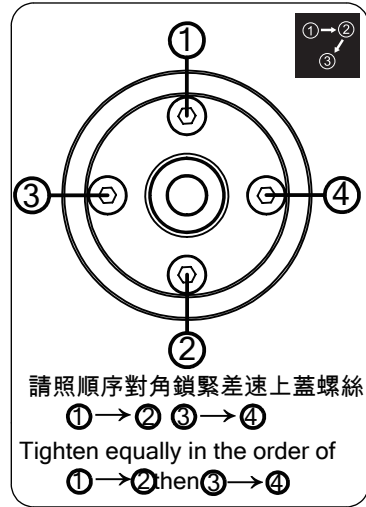

66480336

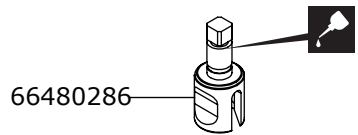
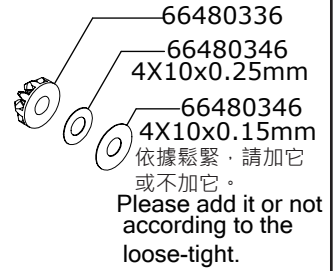
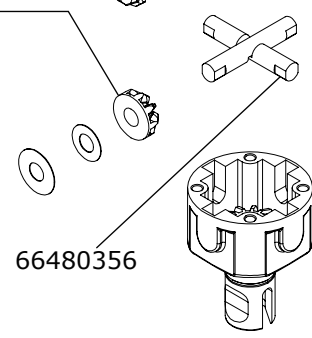

x2







SILICON DIFF OIL # 5000 (Advise)
(建議)

將差速油注入差速殼內至8分滿
Eighty percent full of differential oil into diff cage.

Pour in the oil until the gears are just submerged in oil.

BAG
A

A3 Center Diff

-  --- 4
M2.6X8mm Flat Head Hex Screw
-  --- 2
5X8x0.8mm Washer
-  --- 4
4X10x0.15mm Washer
-  --- 4
4X8x0.25mm Washer

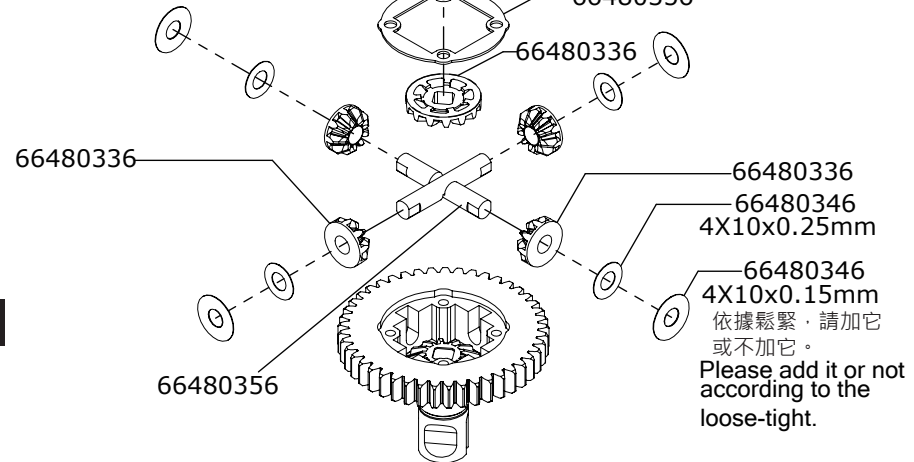
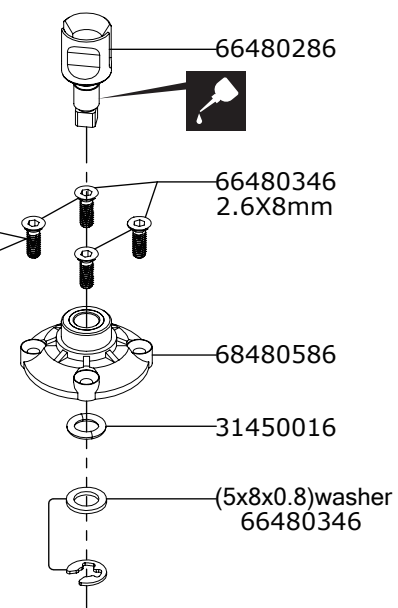
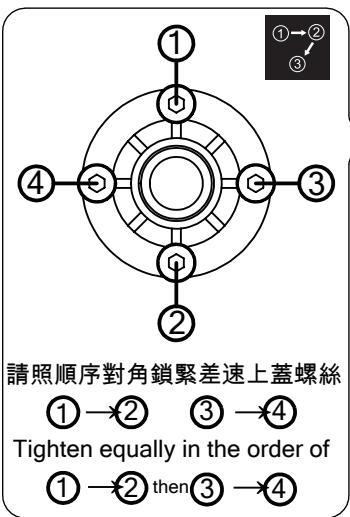
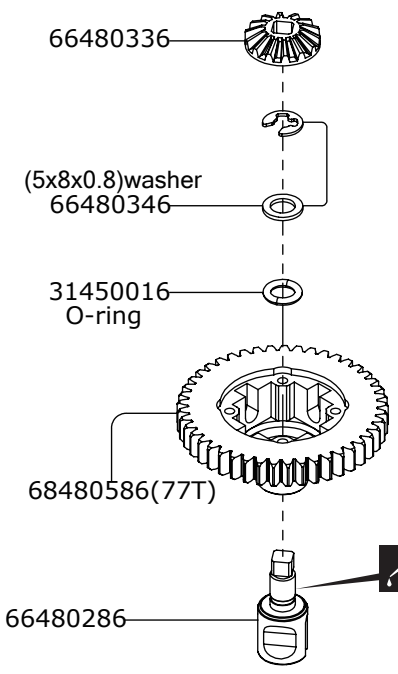



30000

SILICON DIFF OIL # 60000 (Advise) (建議)

將差速油注入差速殼內至8分滿

Eighty percent full of differential oil into diff cage.

Pour in the oil until the gears are just submerged in oil.



BAG A

A4 Front Central Transmission

Front

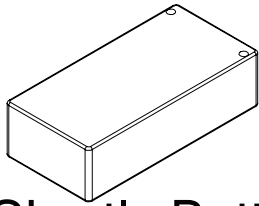

Shortly Battery

- 6
M3X10 Button Head Hex Screw
- 1
M4X3mm Set Screw
- 1
5x11x4mm Ball Bearing
- 1
5x13x4mm Ball Bearing
- 2
10x15x4mm Ball Bearing

!
組裝時請注意齒輪方向
Please notice the
direction of gear.

Front

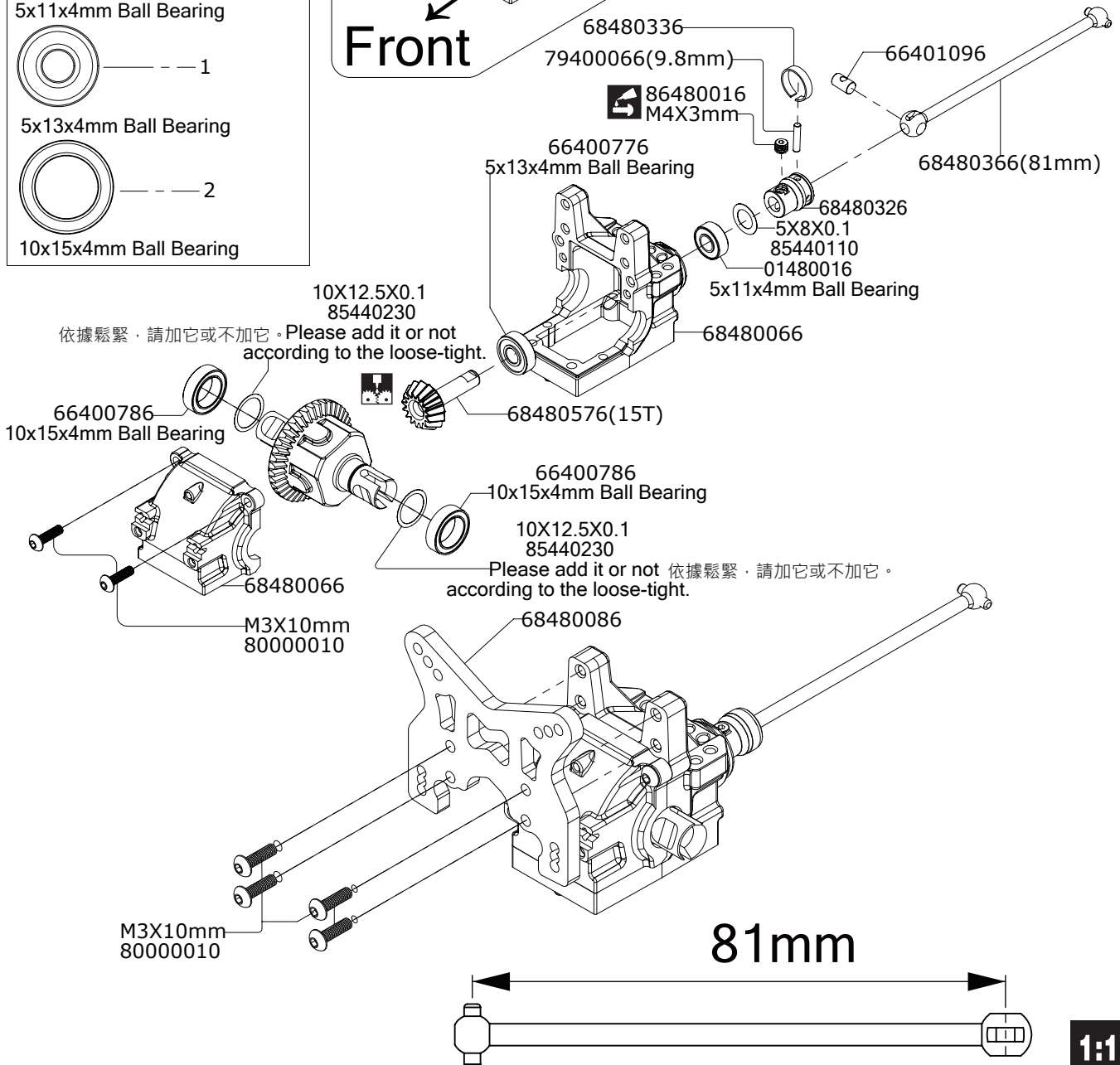

1:1





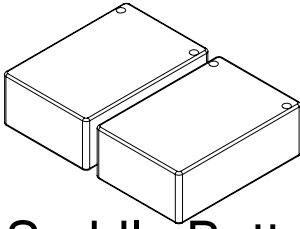

A4 Front Central Transmission

Front



Saddle Battery

-  6
M3X10 Button Head Hex Screw
-  1
M4X3mm Set Screw
-  1
5x11x4mm Ball Bearing
-  1
5x13x4mm Ball Bearing
-  2
10x15x4mm Ball Bearing

!
組裝時請注意齒輪方向
Please notice the
direction of gear.

Front

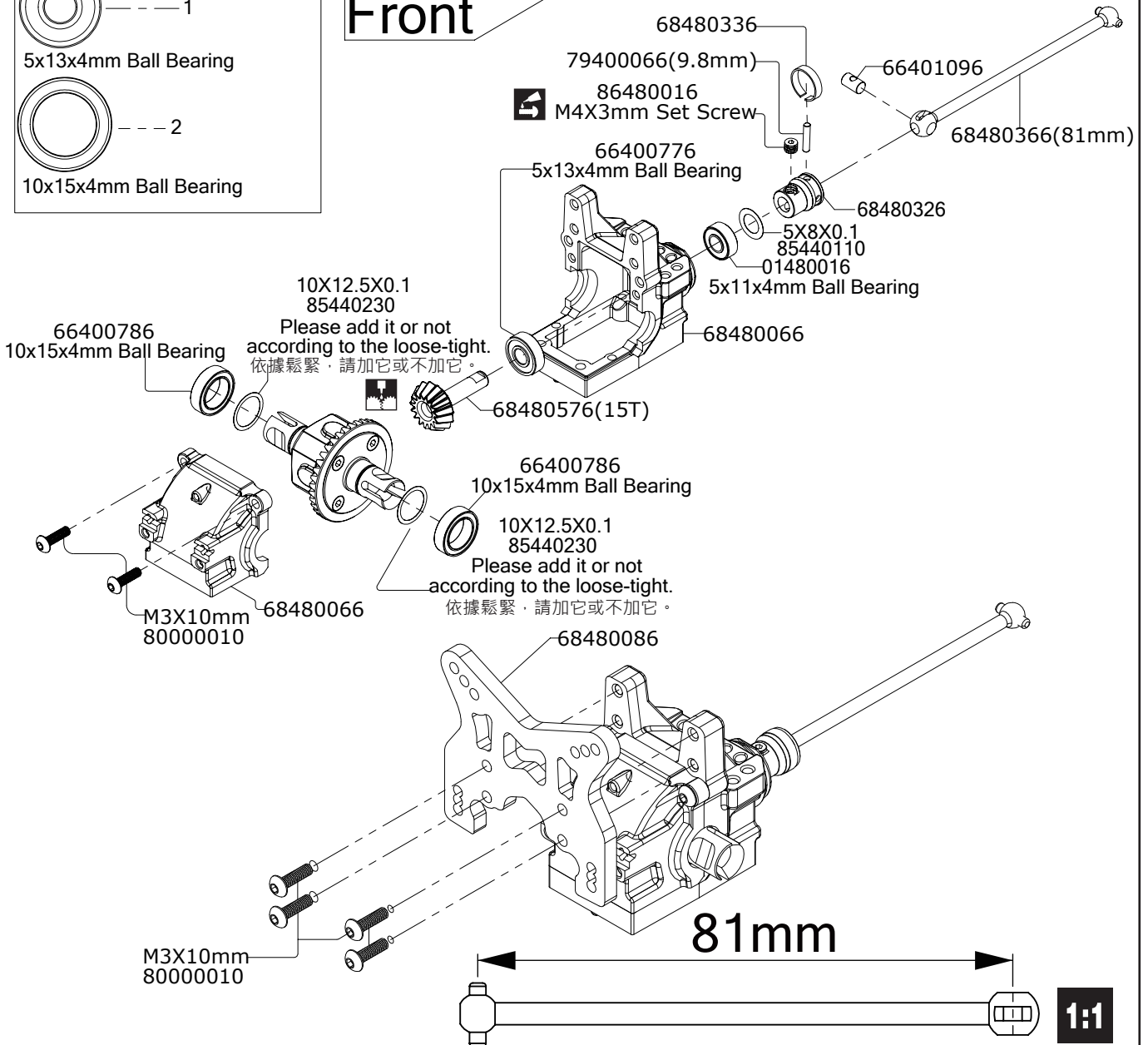

1:1



BAG A

A5 Rear Central Transmission

Rear

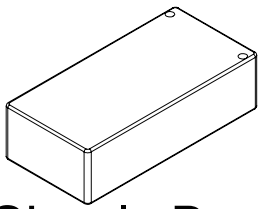

Shortly Battery

- 6
M3X10 Button Head Hex Screw
- 1
M4X3mm Set Screw
- 1
5x11x4mm Ball Bearing
- 1
5x13x4mm Ball Bearing
- 2
10x15x4mm Ball Bearing

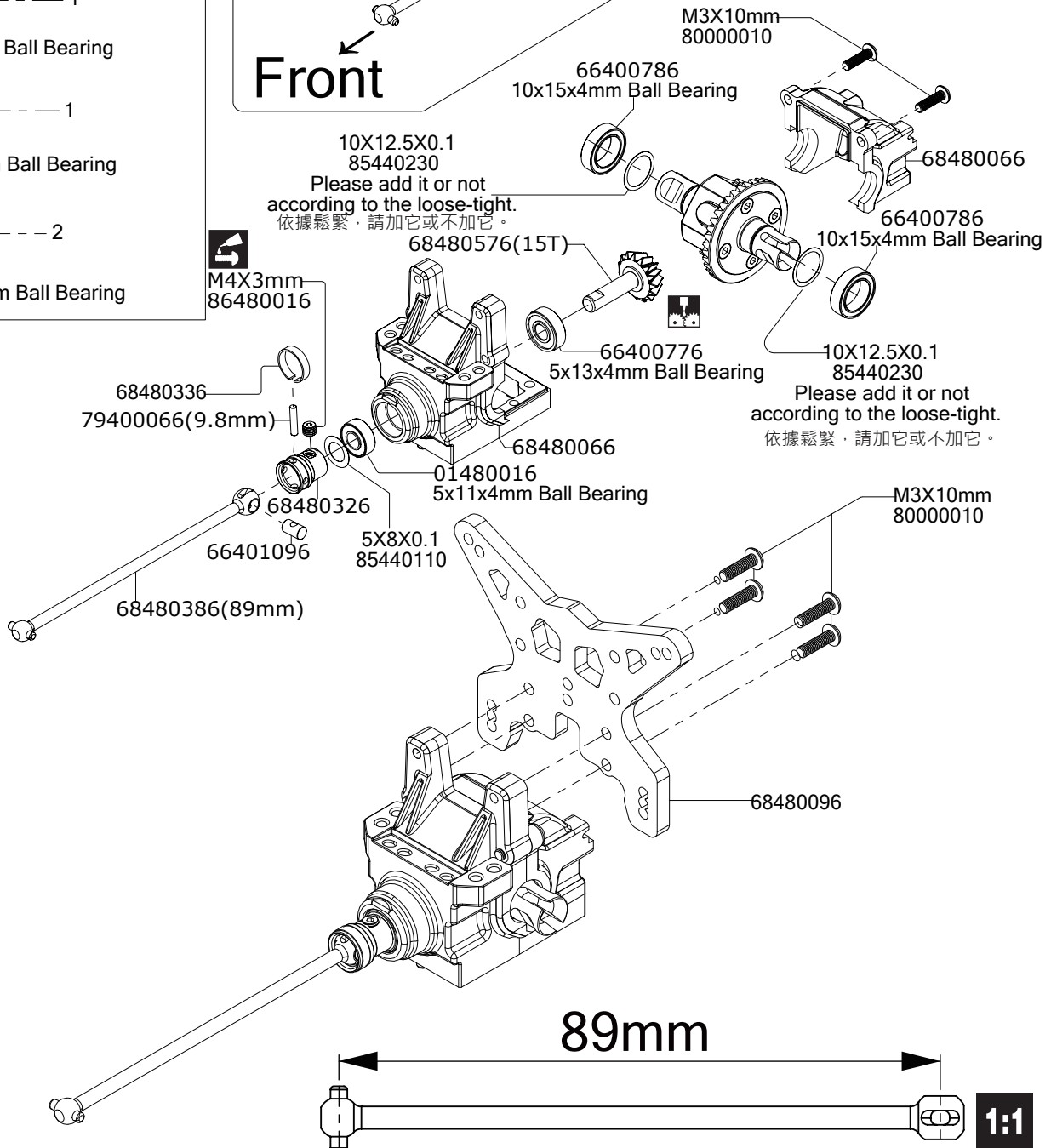
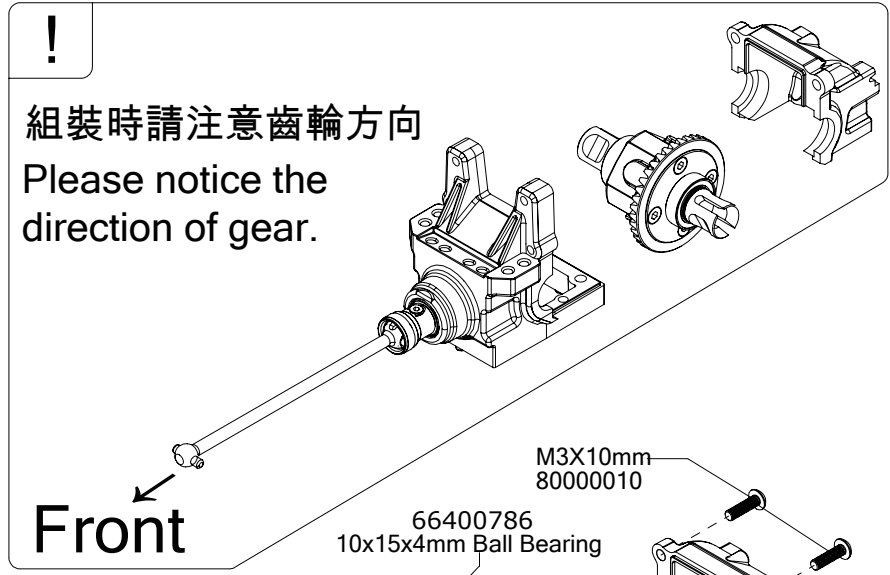





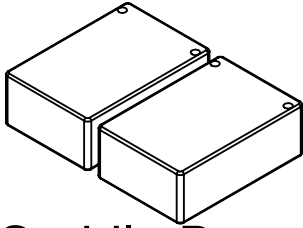

A5 Rear Central Transmission

Rear

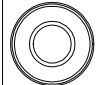

Saddle Battery



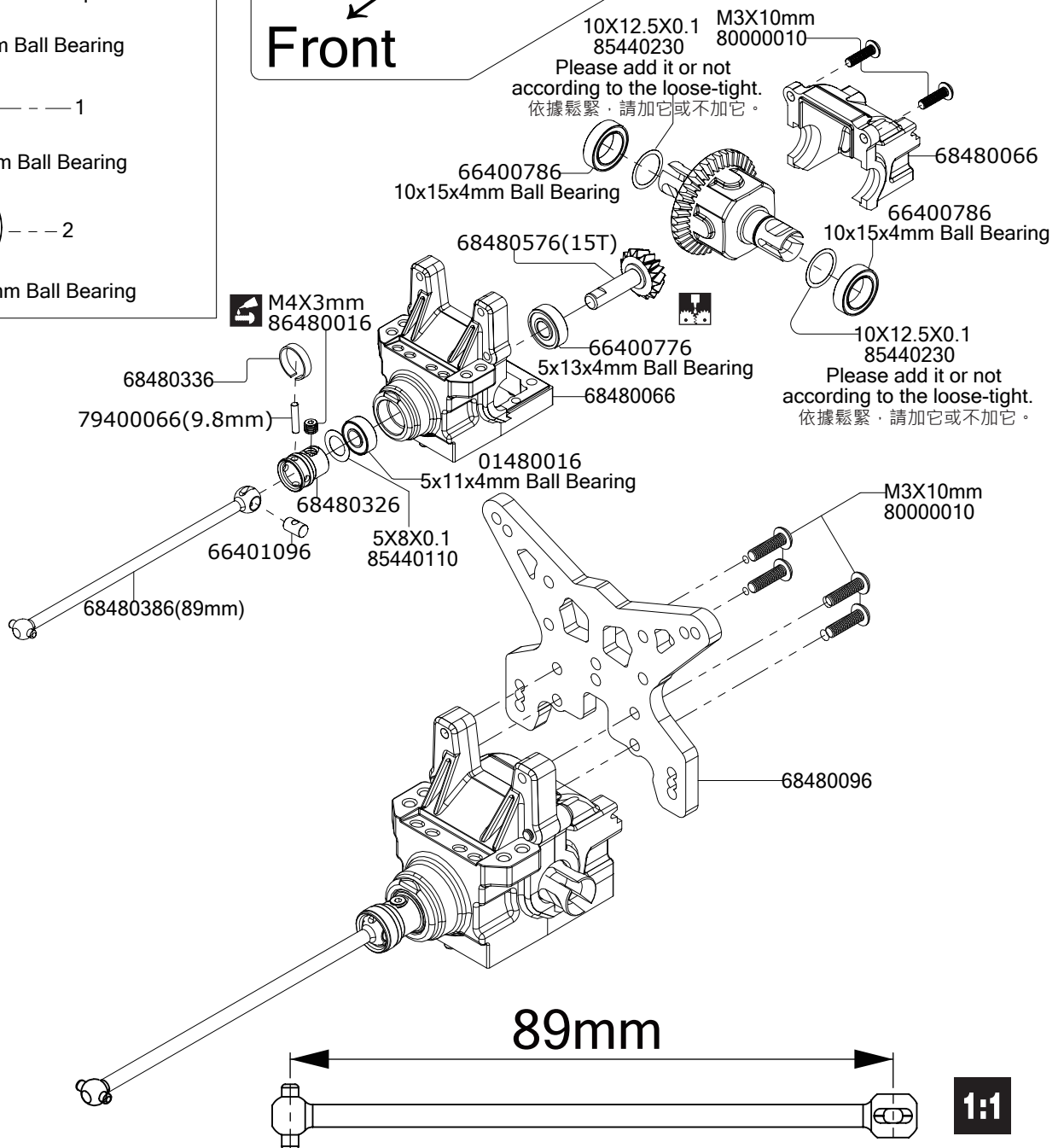
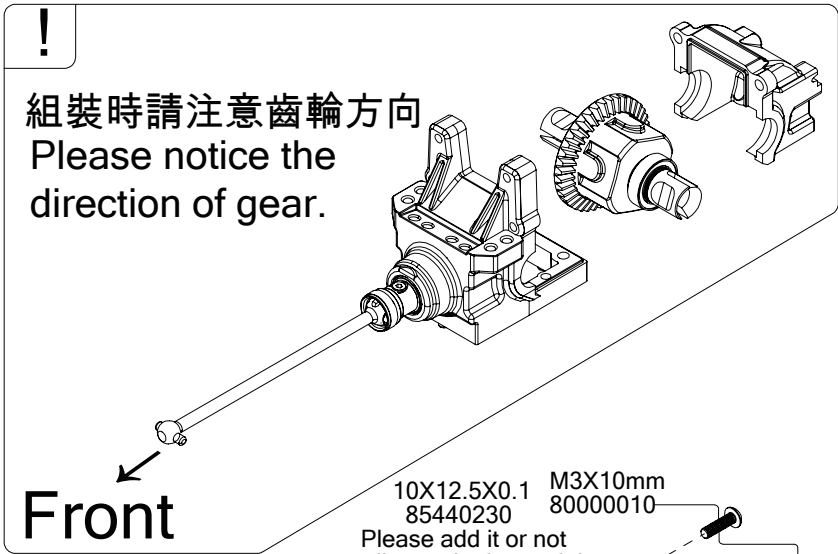

-  6
M3X10 Button Head Hex Screw
-  1
M4X3mm Set Screw
-  1
5x11x4mm Ball Bearing
-  1
5x13x4mm Ball Bearing
-  2
10x15x4mm Ball Bearing





BAG B

B1 Front Assembly

-  --- 2
M2.6X16mm Flat Head Hex Screw
-  --- 2
M3X6mm Flat Head Hex Screw
-  --- 2
M3X10mm Flat Head Hex Screw
-  --- 2
M3X14mm Flat Head Hex Screw

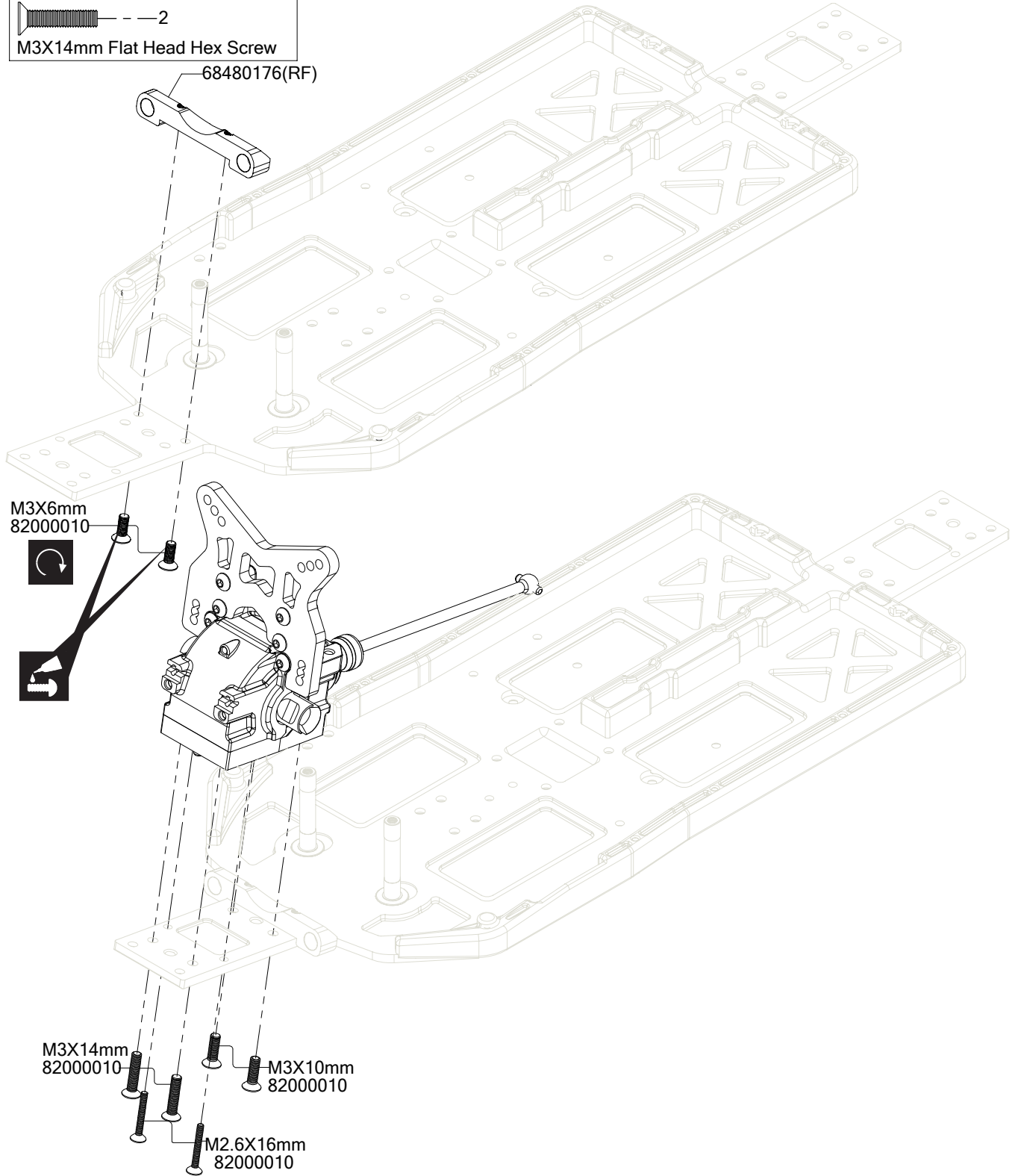

Part Bags used.



Tighten securely.



Apply threadlocker (screw cement)



B2 Front Spindle (Left Side)

Left Side



- 2
M3X12 Button Head Hex Screw
- 2
M4.8X6mm Ball Studs
- 1
5X11X4mm Ball Bearing
- 1
5X13X4mm Ball Bearing
- 1
M3X3mm Set Screw

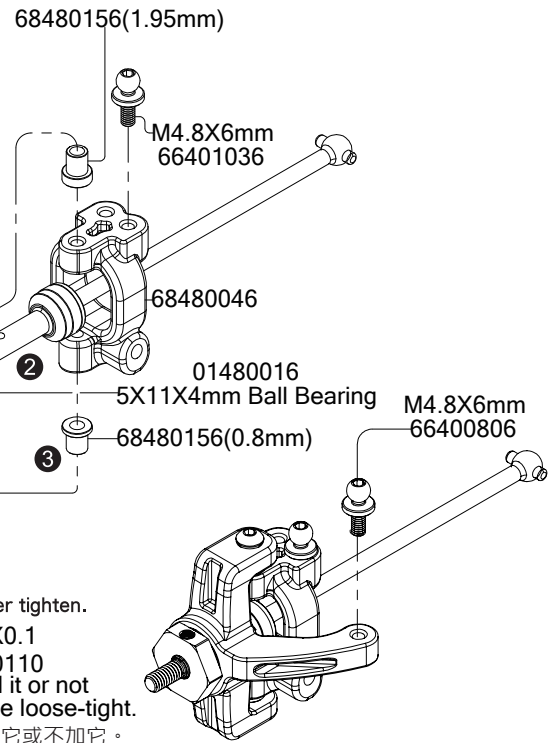
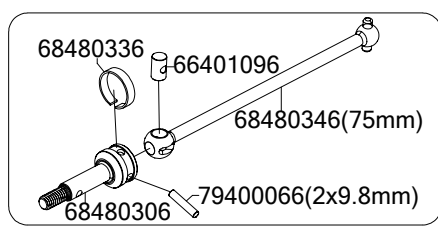

75mm

1:1



B2 Front Spindle (Right Side)

Right Side



- 2
M3X12 Button Head Hex Screw
- 2
M4.8X6mm Ball Studs
- 1
5X11X4mm Ball Bearing
- 1
5X13X4mm Ball Bearing
- 1
M3X3mm Set Screw

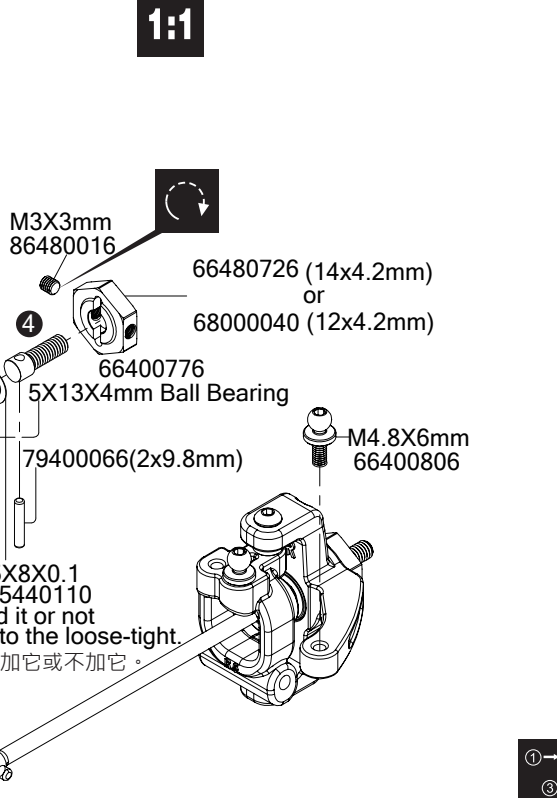
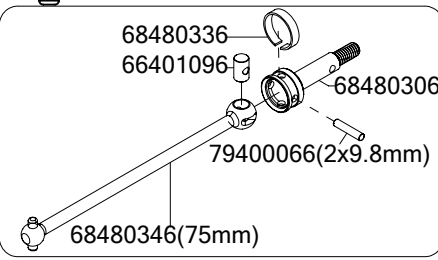

75mm

1:1



Part Bags used.



Tighten securely.



Assemble in the specified order.



Do not over tighten.



B3 Front Suspension

- 2
M3X6mm Flat Head Hex Screw
- 2
M3X8mm Flat Head Hex Screw
- 2
M2.6X4mm Button Head Hex Screw
- 2
M3X3mm Set Screw
- 2
M3X10mm Set Screw

- M3X3mm
86480016
- 68480476
- M3X10mm
86480016
- 66400066

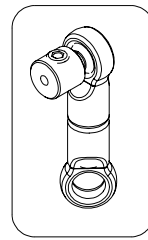

1:1

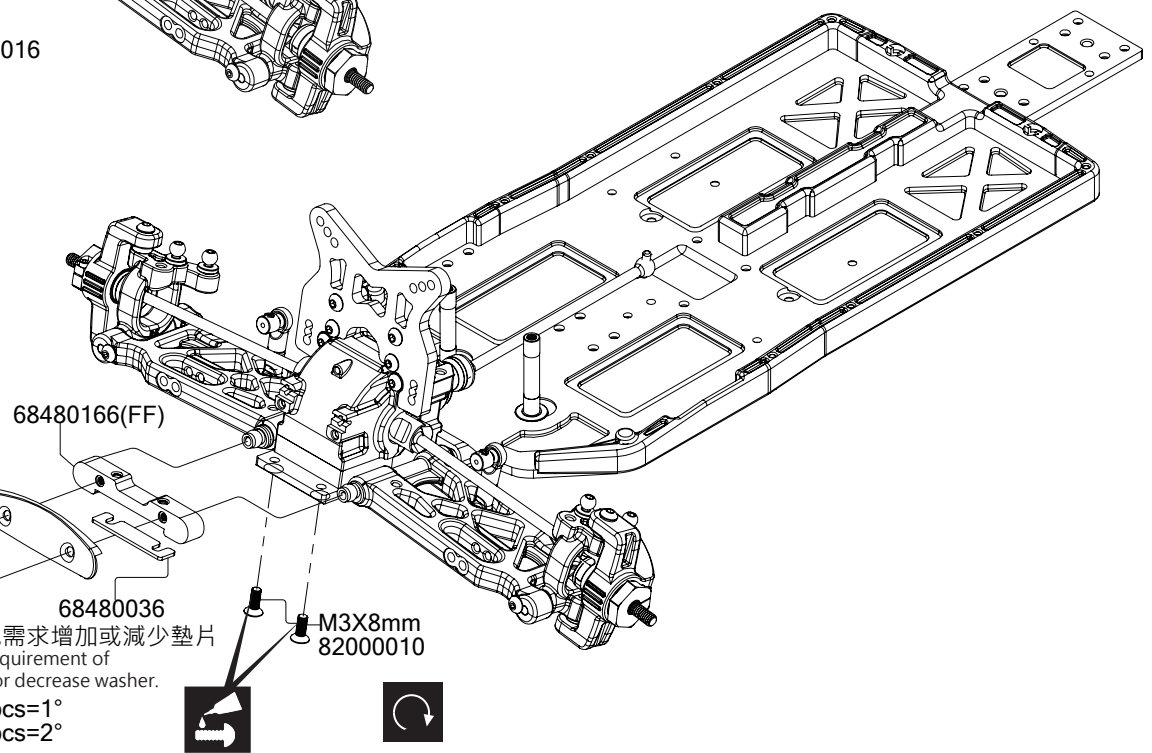
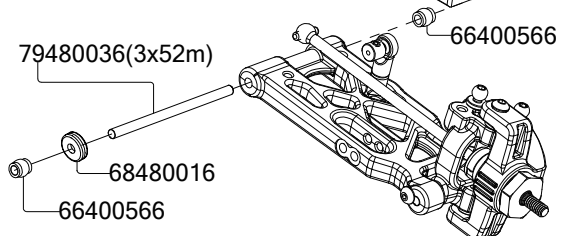
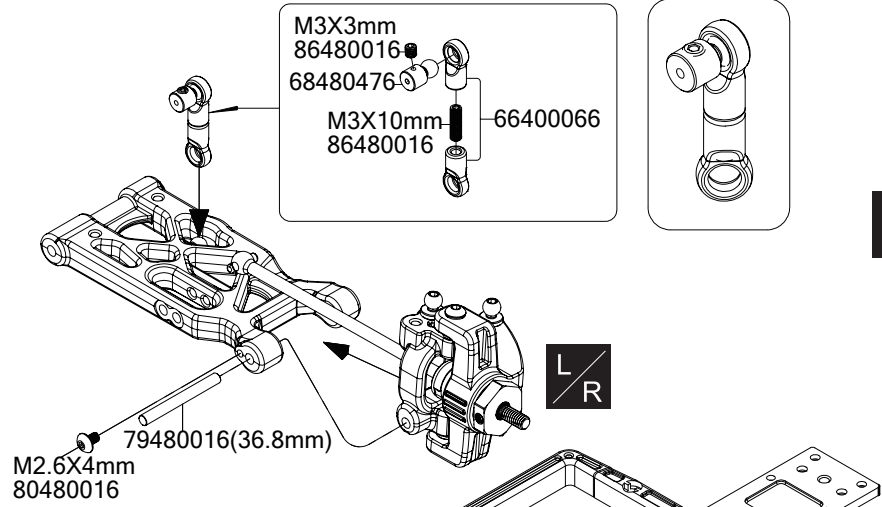



因應不同場地需求增加或減少墊片
With different requirement of
places, increase or decrease washer.
1pcs=1°
2pcs=2°



B4 Front Suspension



-  2
M4.8X8mm Ball Studs
-  2
M3 Lock Nut

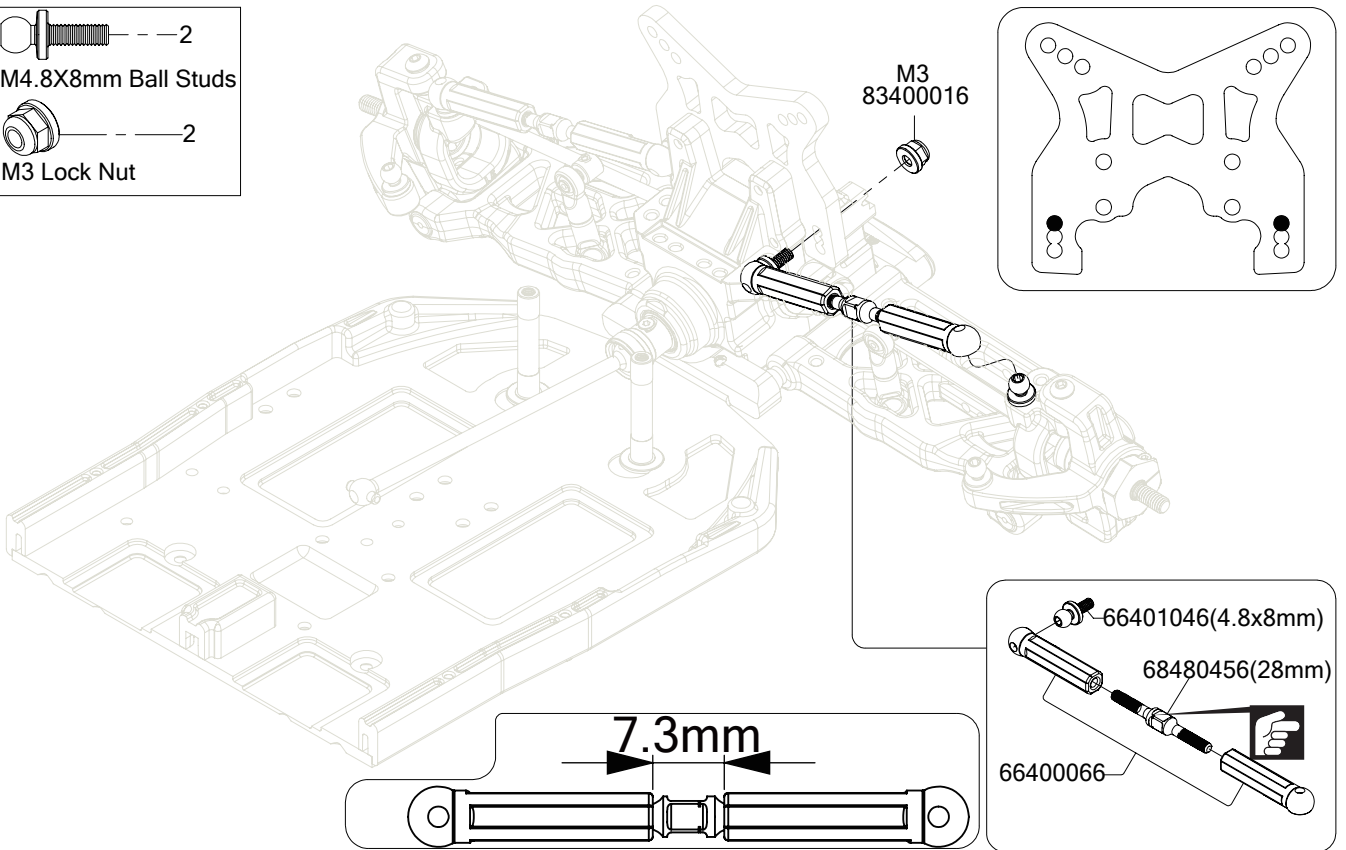

B5 Front Suspension

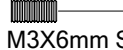

-  2
M3X8mm Button Head Hex Screw
-  2
M3X6mm Set Screw

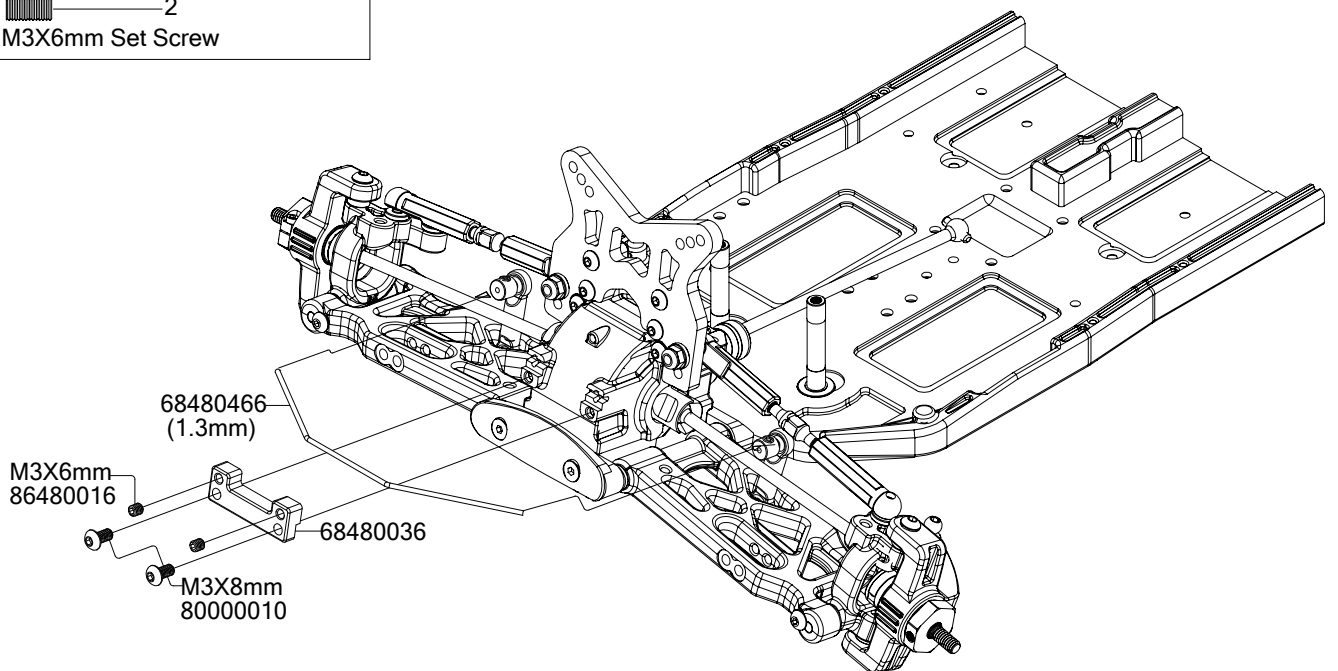





Part Bags used.



Note the direction.

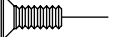

C1 Rear Assembly

-  --- 2
M2.6X16mm Flat Head Hex Screw
-  --- 2
M3X8mm Flat Head Hex Screw
-  --- 2
M3X10mm Flat Head Hex Screw
-  --- 2
M3X14mm Flat Head Hex Screw
-  --- 4
M3X10mm Button Head Hex Screw

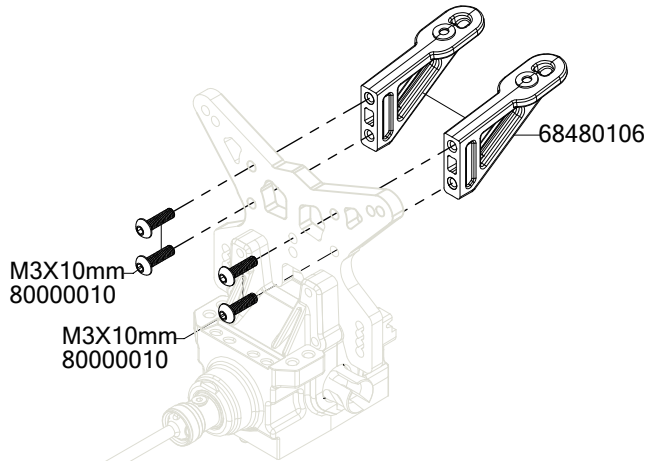

68480036
 因應不同場地需求增加或減少墊片
 With different requirement of
 places, increase or decrease washer.
 1pcs=1°
 2pcs=2°

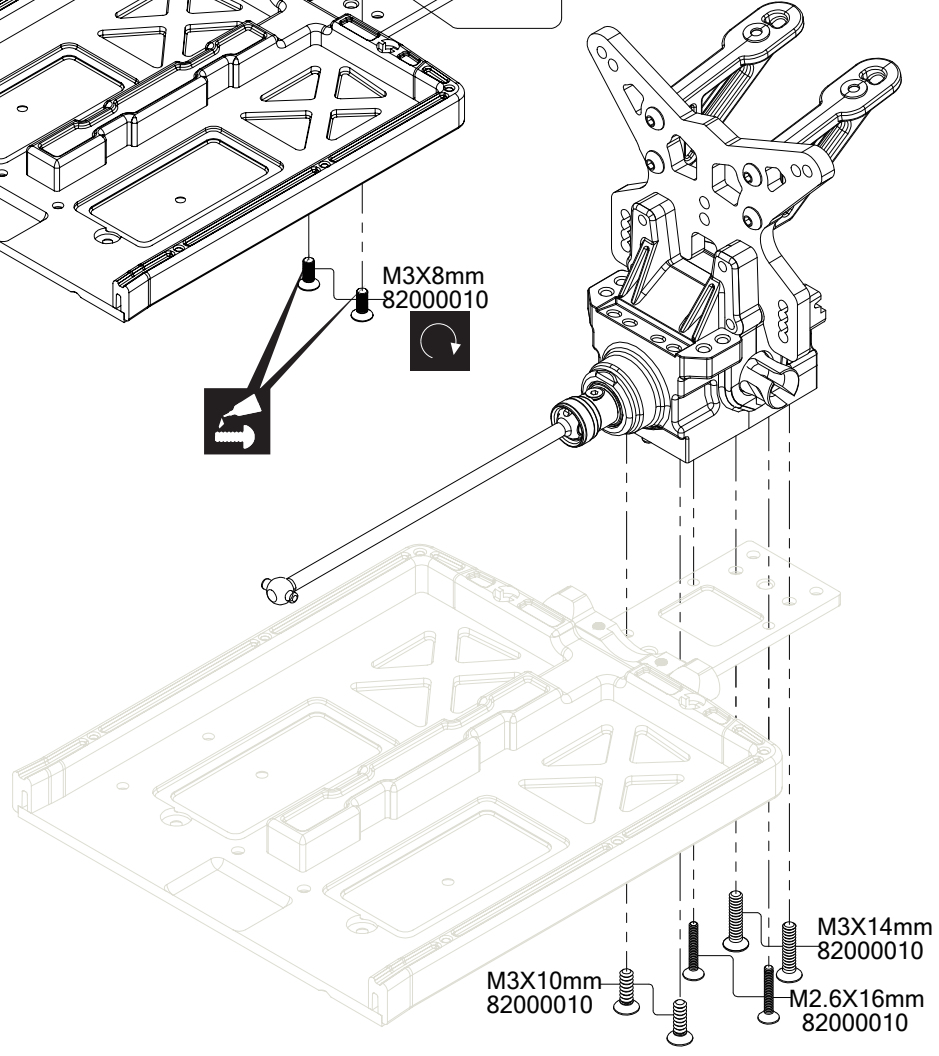
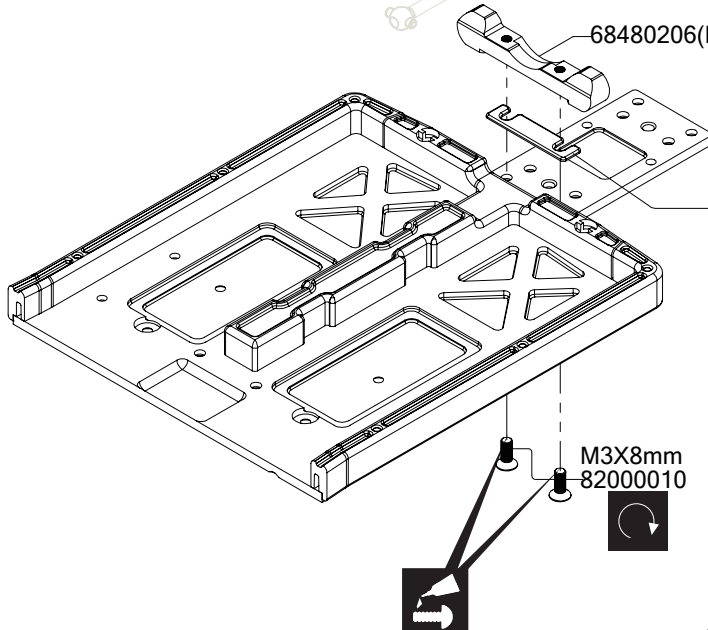



C2 Rear Suspension



- 2
M3X6mm Flat Head Hex Screw
- 2
M2.6X4mm Button Head Hex Screw
- 2
M3x3mm Set Screw
- 2
M3x10mm Set Screw
- 2
5x13x4mm Ball Bearing
- 2
10x15x4mm Ball Bearing

- M3X3mm 86480016
- 68480476
- 66400066
- M3X10mm 86480016

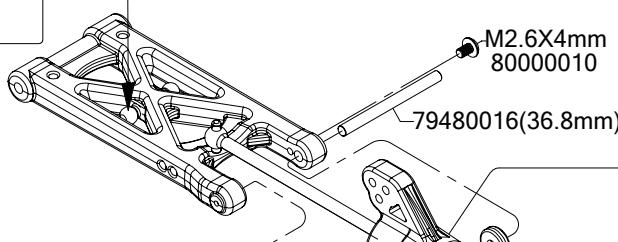
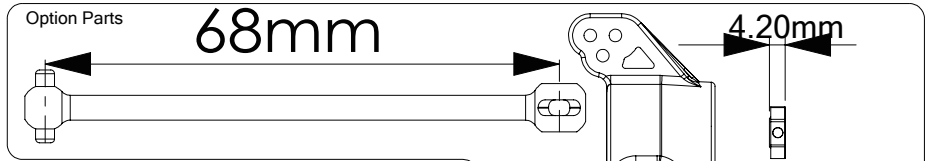
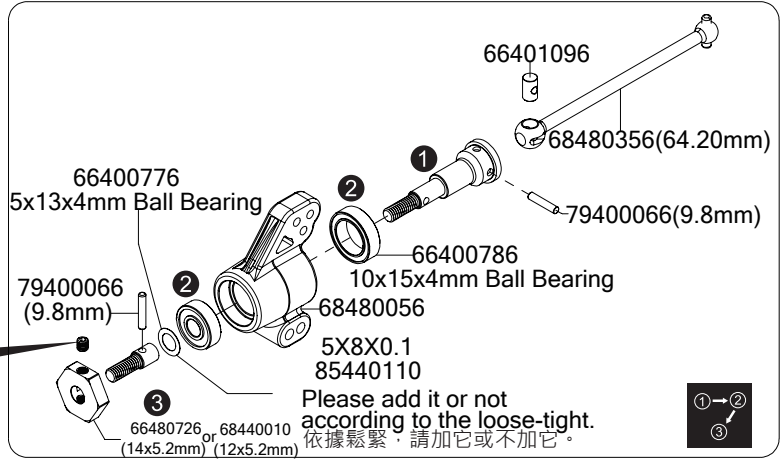

如需要調整至內孔需要更換狗骨長度為68mm(68480376)
(狗骨需額外加購)六角輪座12X4.2mm(68000040)or
14X4.2mm(66480726)
If you need to adjust to bore, you have to change the bone
length 68mm(NO.68480376 bone need to additionally purchase.)
Hexagonal Wheel Stand(68000040)or14x4.2mm(66480726)

1:1

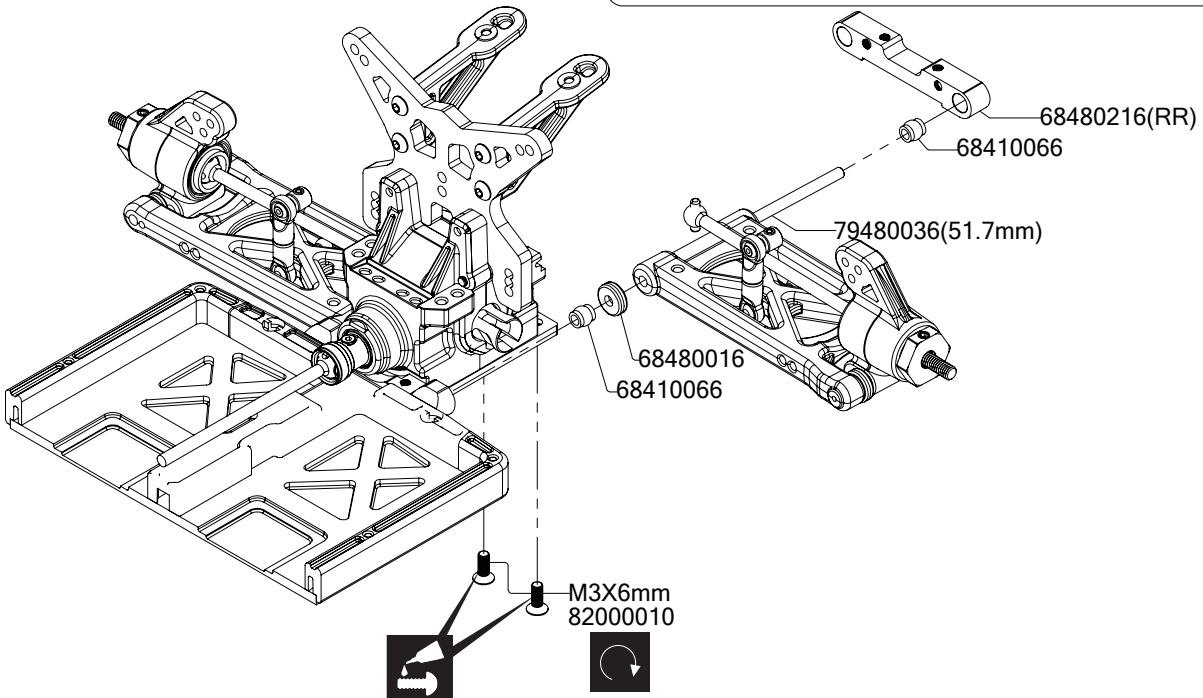
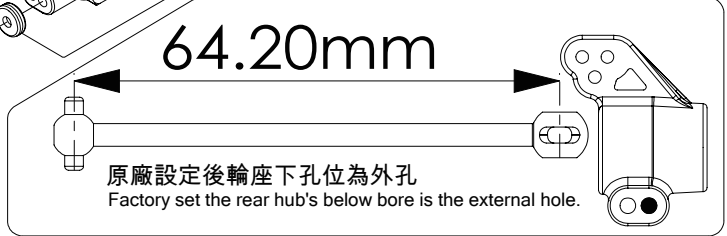

Part Bags used.

Do not over tighten.

Assemble left and right sides the same way.

True-to-scale diagram. Tighten securely.



C3 Front Suspension



- 2
4.8X6 Ball Studs
- 2
4.8X8 Ball Studs
- 2
M3 Lock Nut

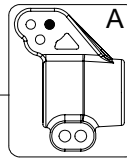
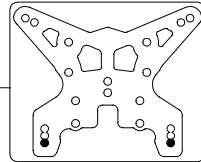
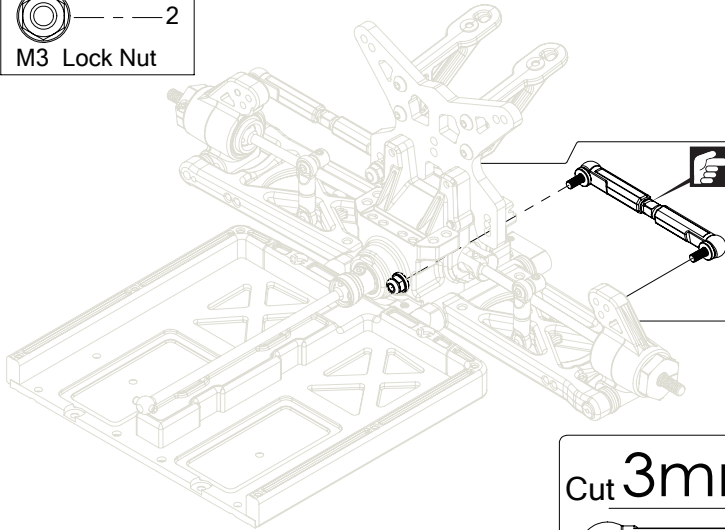
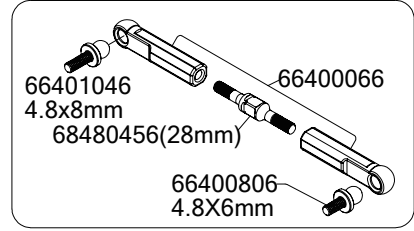
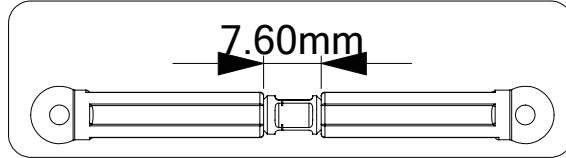

or

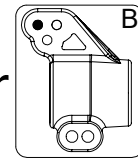

注意!!如使用B孔位
請自行裁切塑膠球頭3mm
Notice!!If you use B hole,
please cut the plastic ball
3mm by yourself!

Cut 3mm

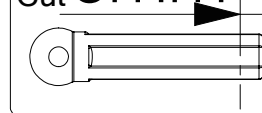

8.50mm

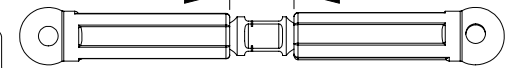

C4 Front Suspension



- 2
M3X8mm Button Head Hex Screw
- 2
M3X6mm Set Screw

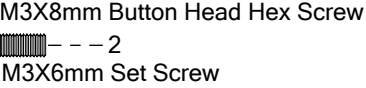

M3X6mm
86480016

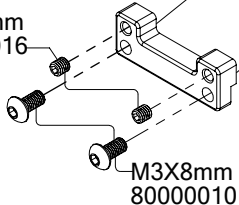



1.3mm
68480466

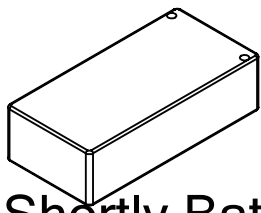

D1 Steering



Shortly Battery

-  2
-  3
-  2

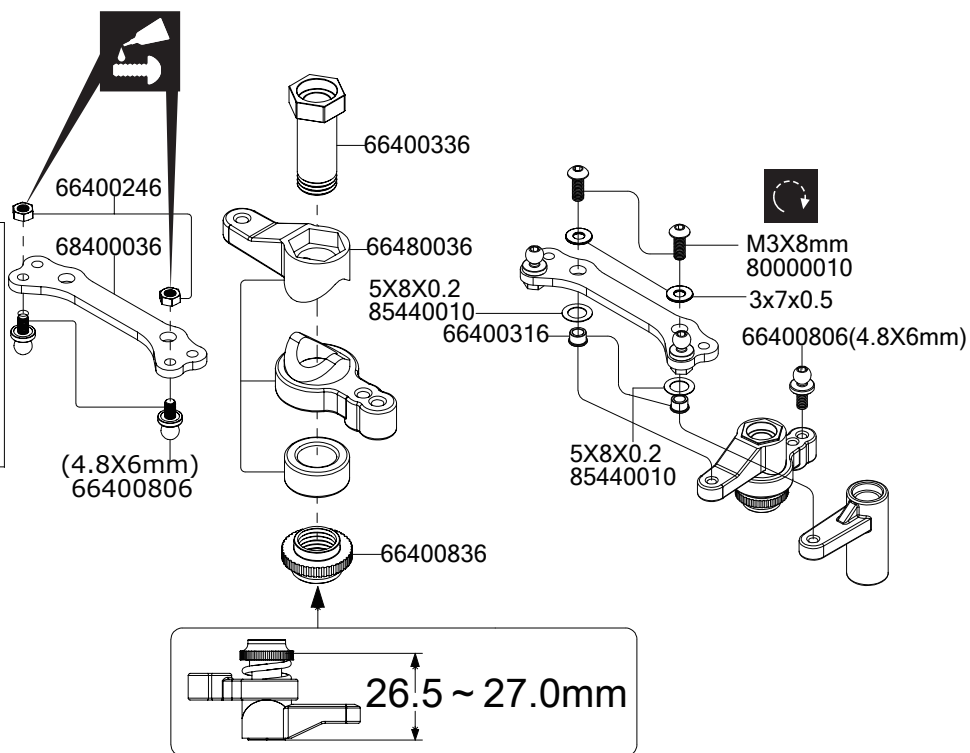

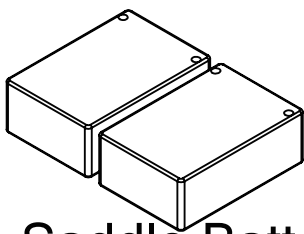

D1 Steering

OR



Saddle Battery

-  2
-  1
-  2

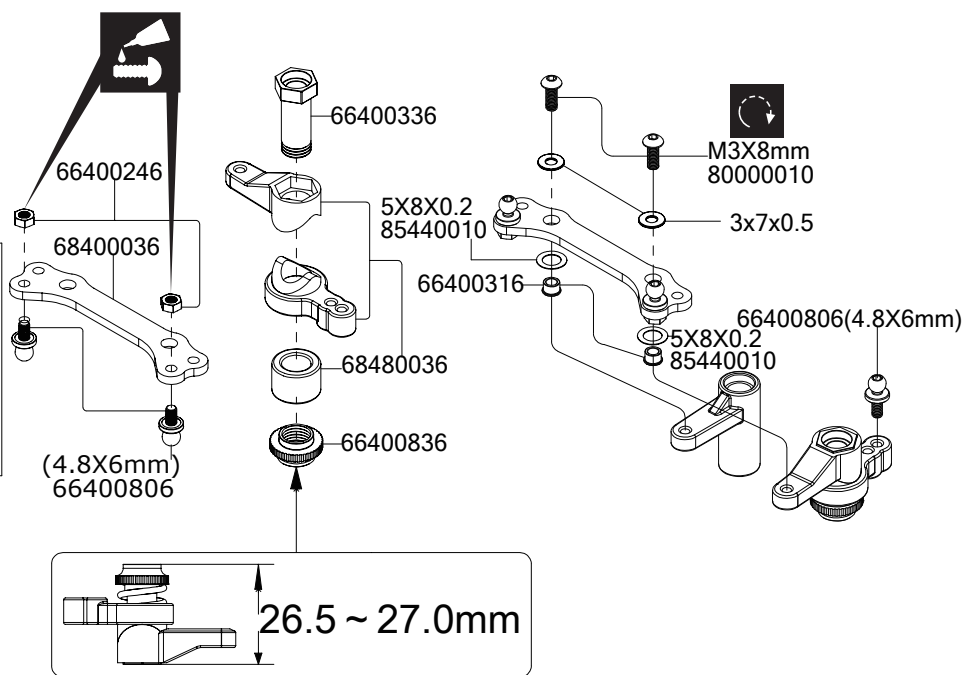

Part Bags used.



Do not over tighten.



Apply threadlocker (screw cement)



D2 Steering

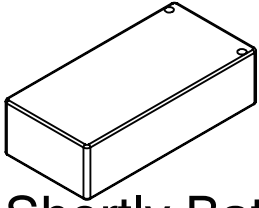

Shortly Battery

- 2
- M3X6mm Button Head Hex Screw
- 4
- 5X8X2.5mm Ball Bearing

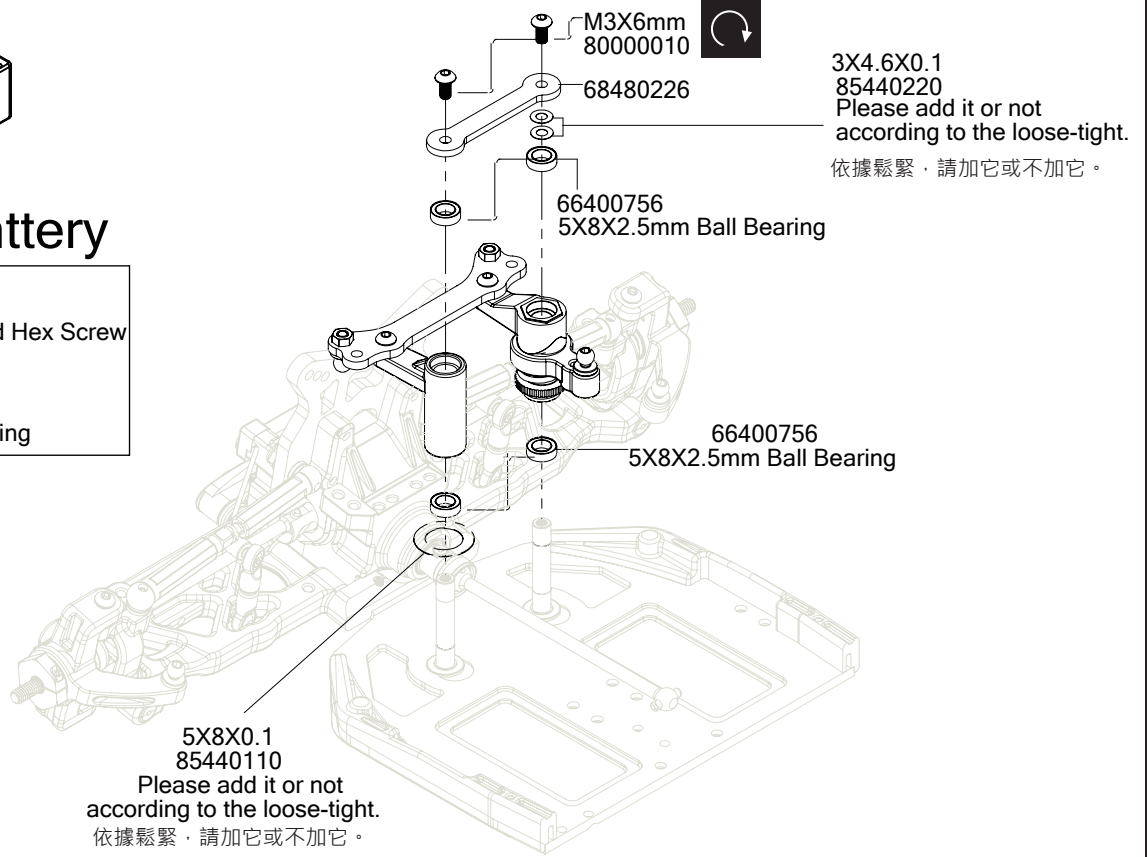

D2 Steering

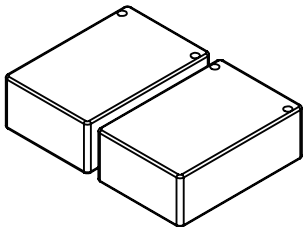

Saddle Battery

- 2
- M3X6mm Button Head Hex Screw
- 4
- 5X8X2.5mm Ball Bearing

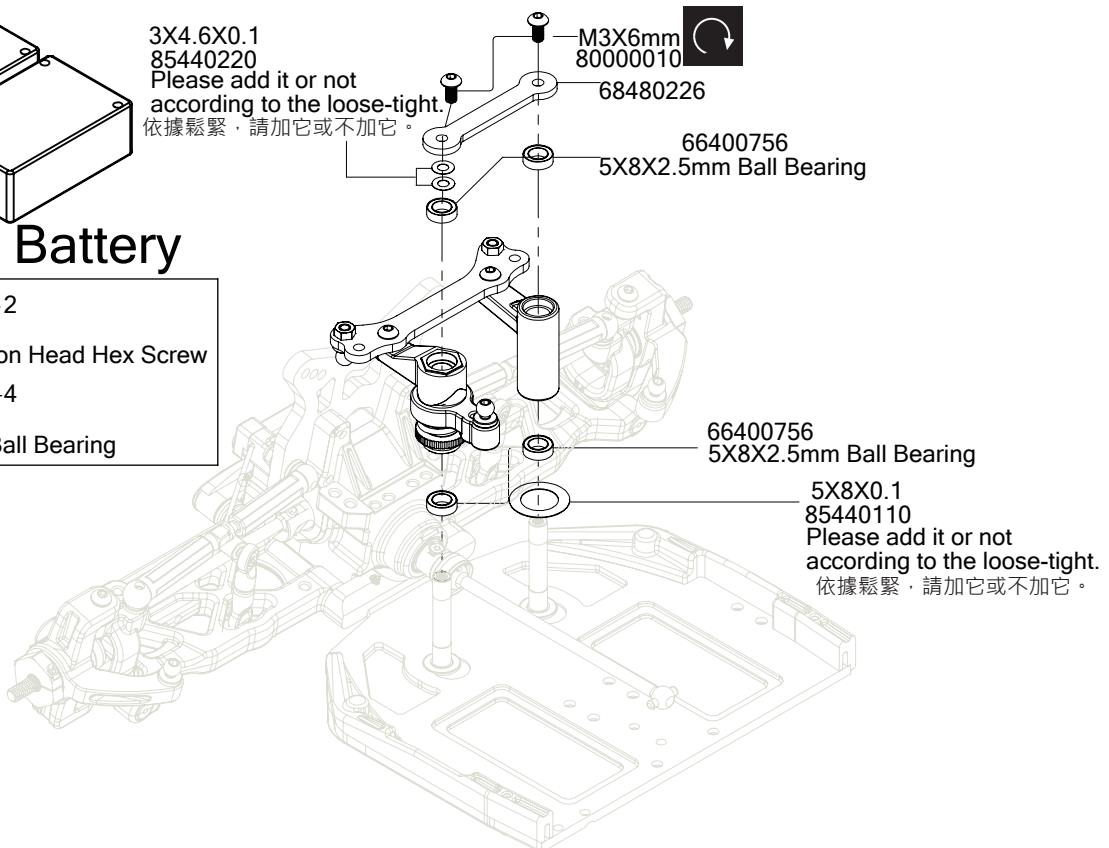





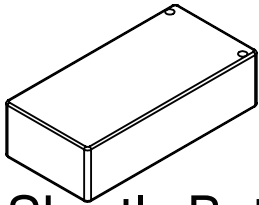

D3 Steering Servo



Shortly Battery

-  4
M3X8mm Button Head Hex Screw
-  3
M3X8mm Flat Head Hex Screw
-  1
4.8X6mm Ball Studs
-  4
3X6.6X0.9 Washer (Al Red)

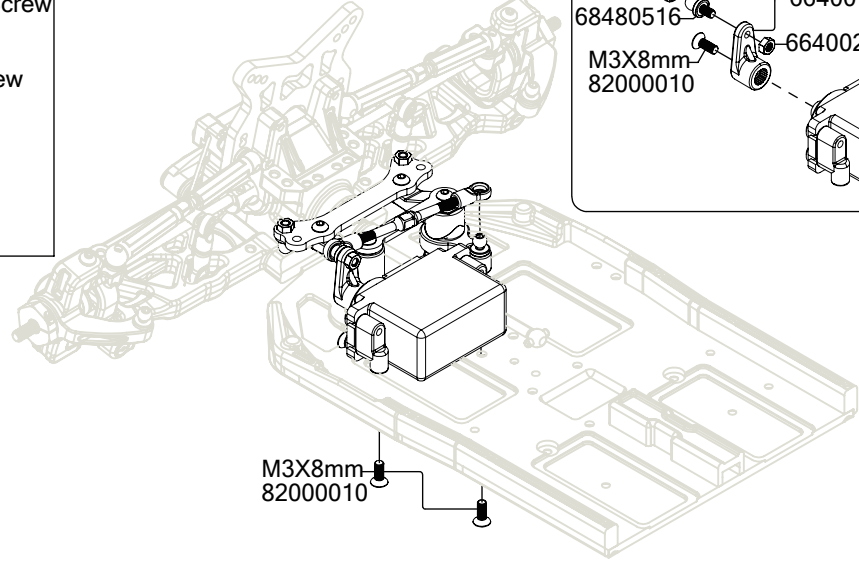
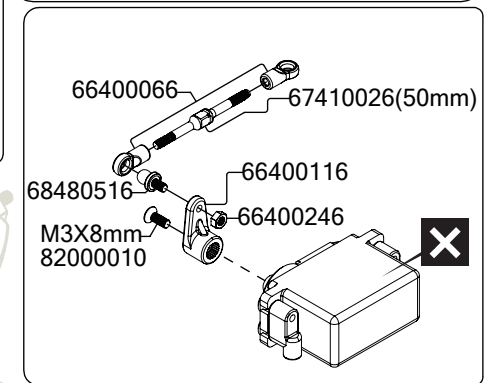
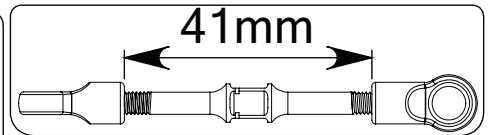
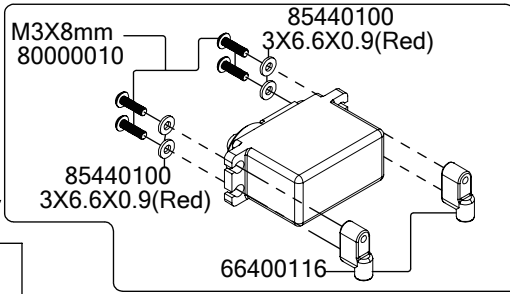





M3X8mm 82000010

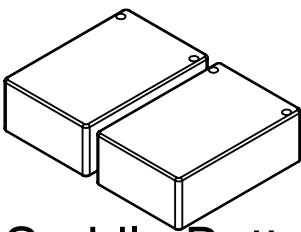

D3 Steering Servo



Saddle Battery

-  3
M3X8mm Flat Head Hex Screw
-  4
M3X8mm Button Head Hex Screw
-  1
M3X12mm Set Screw
-  1
4.8X6mm Ball Studs
-  4
3X6.6X0.9 Washer (Al Red)

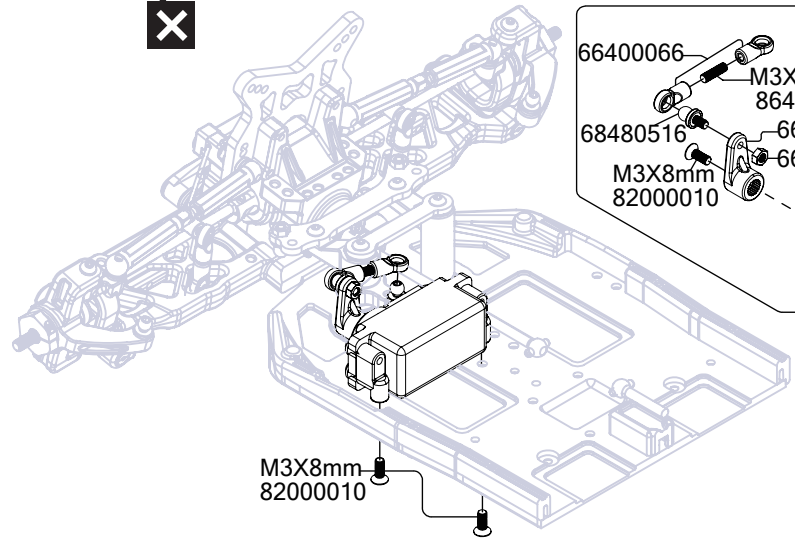
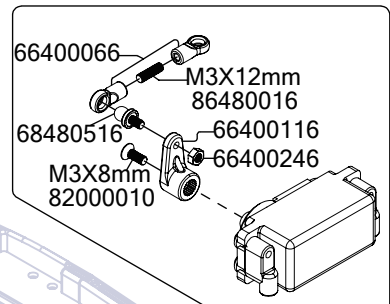
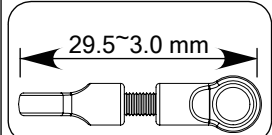
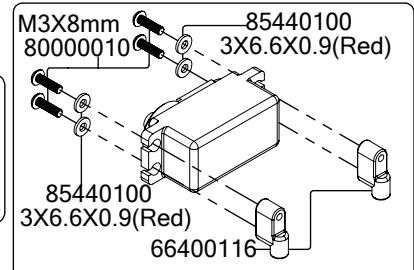
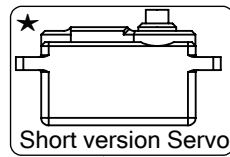

M3X8mm 82000010



Part Bags used.



Must be purchased separately.



BAG
D

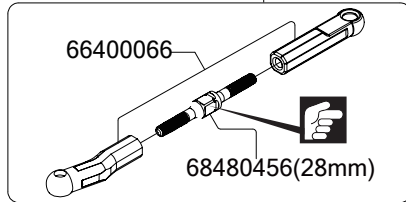
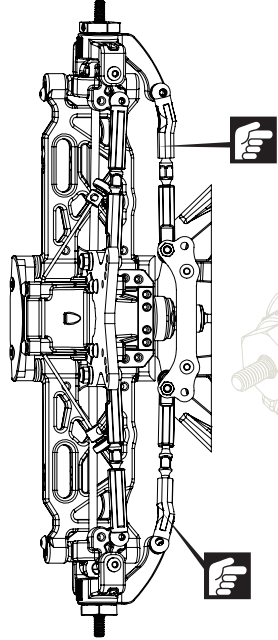
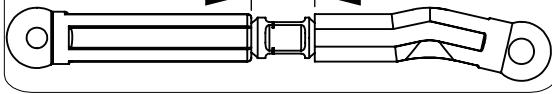

D4 Steering

6.2~6.3mm



D5 Body Mounts

BAG
D

-  --- 1
M3X8mm Button Head Hex Screw
-  --- 3
M2.6X6mm Flat Head Hex Screw

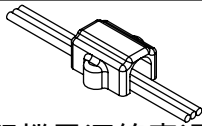

將伺服機電源線穿過整線夾，
避免伺服機電源線被中央傳動系統夾斷
Servo power cord through the cable clips.
To avoid servo power cord pinched off mid drivetrain system.

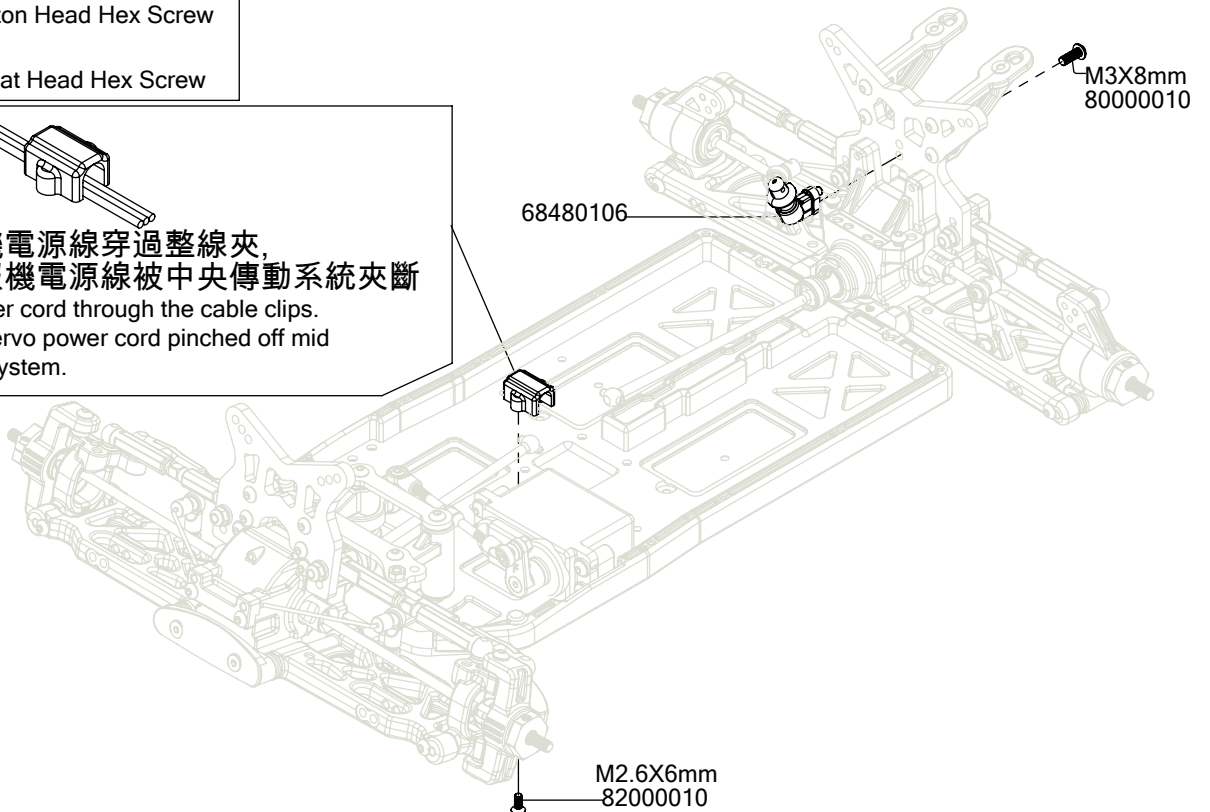



D6 Gear Piff Assembly

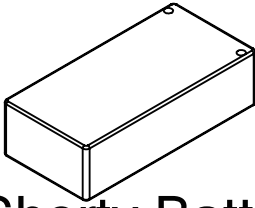

Shorty Battery

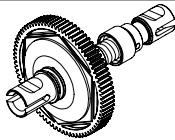
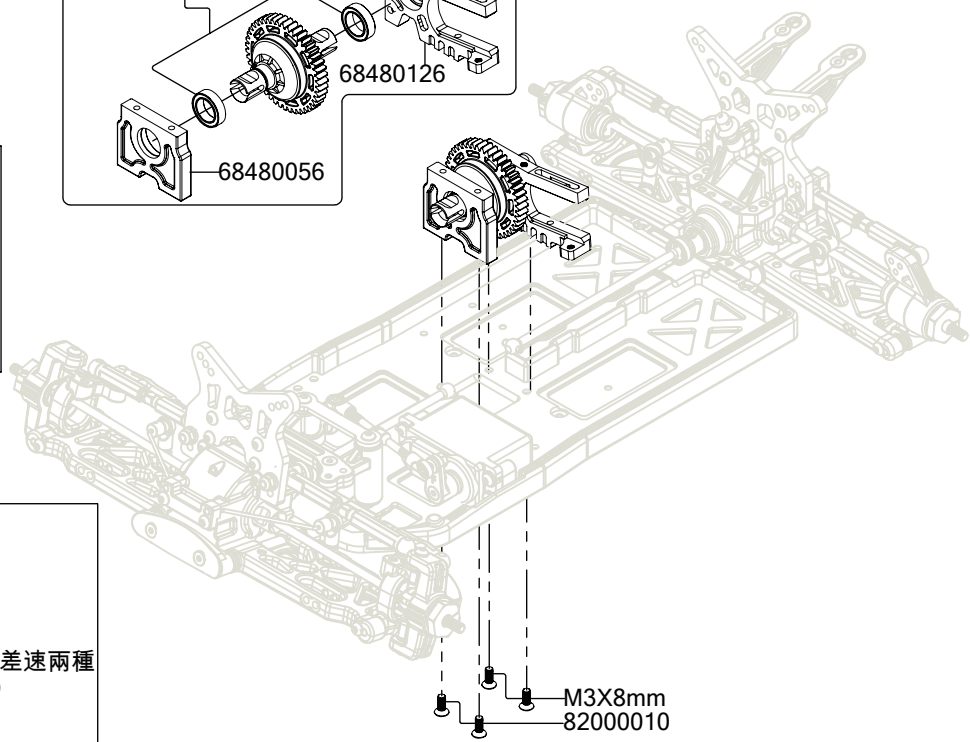
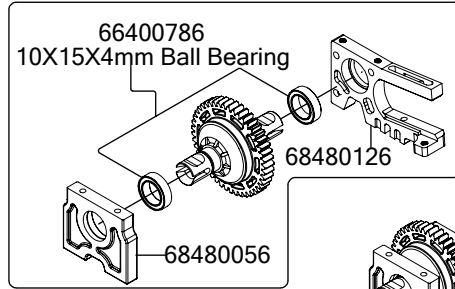
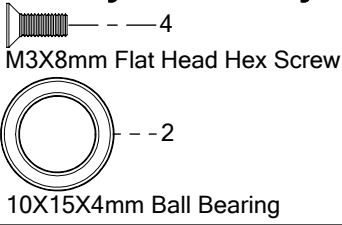

在中置傳動系統可選擇紐線與齒輪差速兩種
(選擇扭限傳動要另外購買)

In mid-drivetrain system can choose in two ways(Differential&gear diff)
(It will cost extra if one choose differential drivetrain.)



D6 Gear Piff Assembly

OR

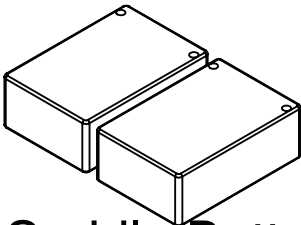

Saddle Battery

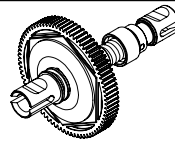
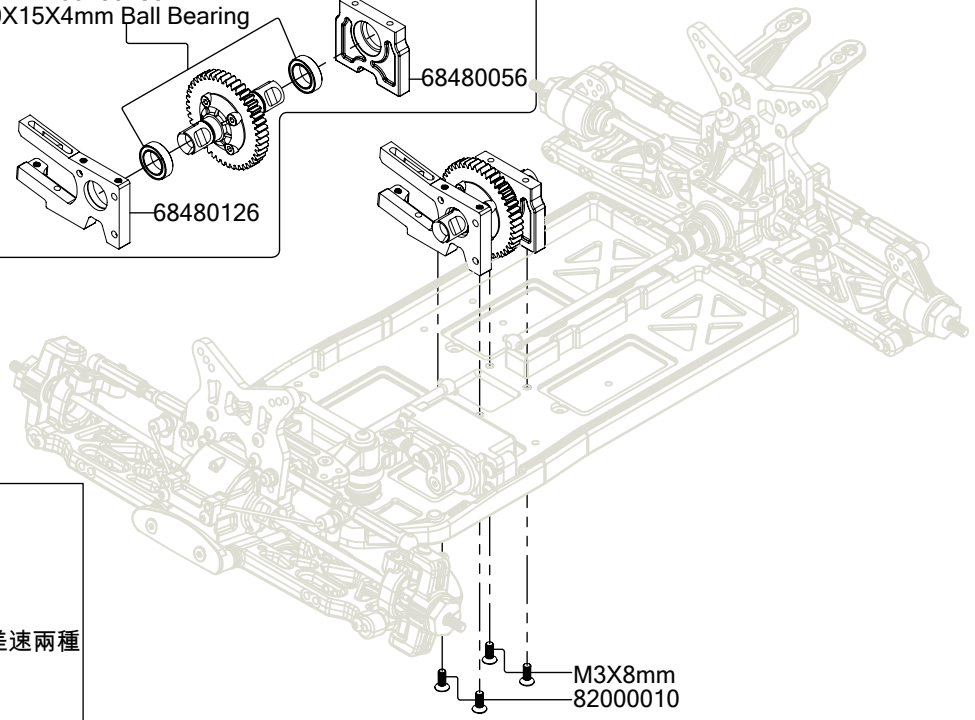
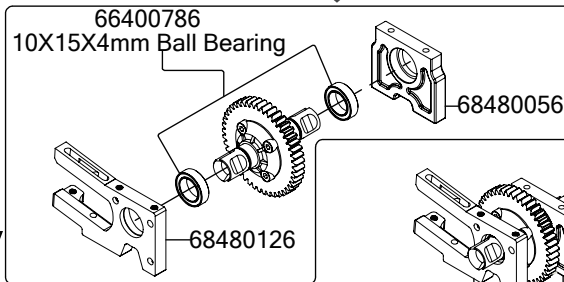
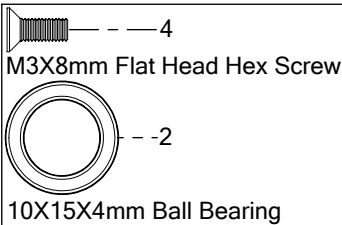



在中置傳動系統可選擇紐線與齒輪差速兩種
(選擇扭限傳動要另外購買)

In mid-drivetrain system can choose in two ways(Differential&gear diff)
(It will cost extra if one choose differential drivetrain.)



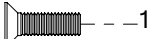



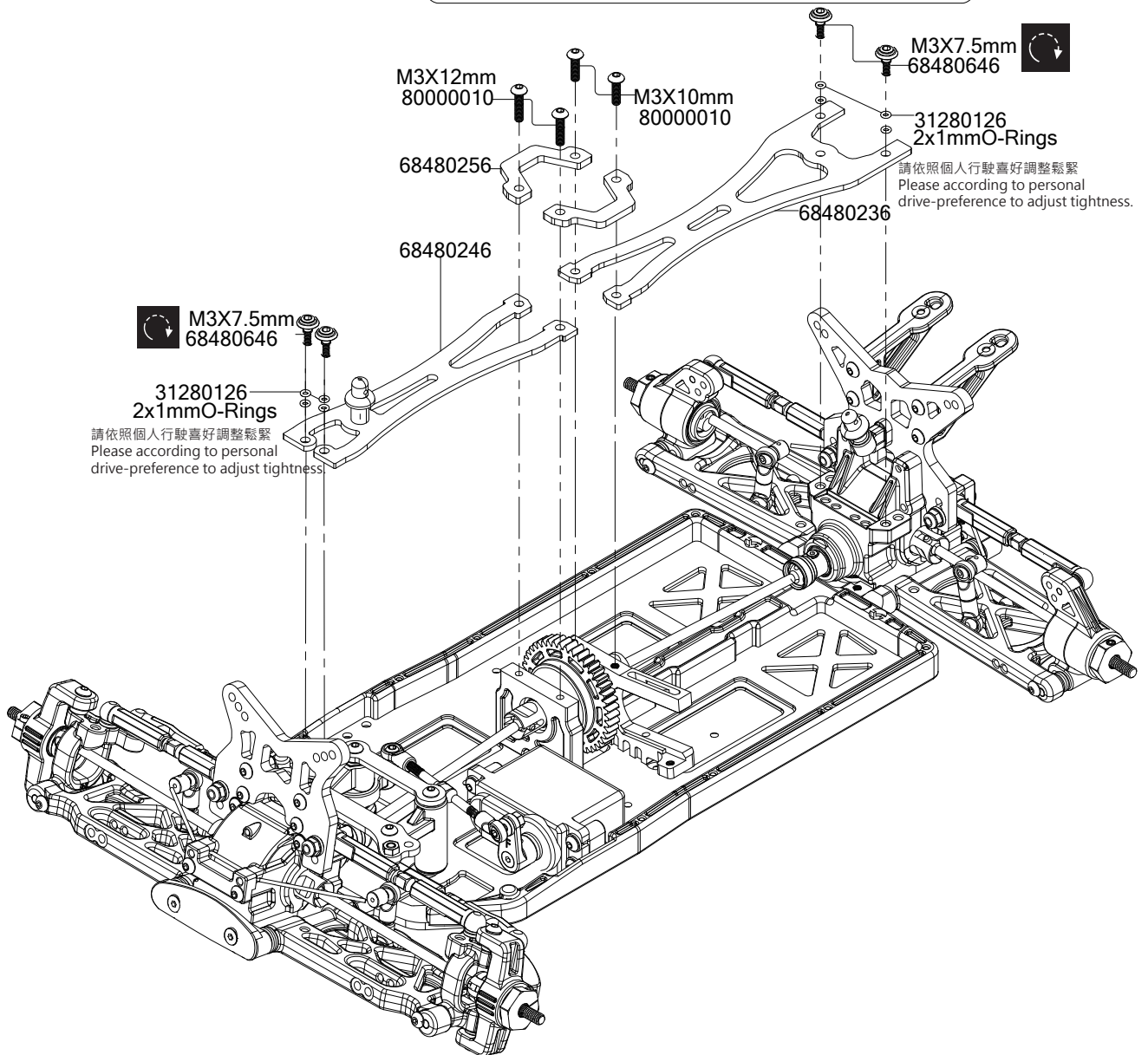
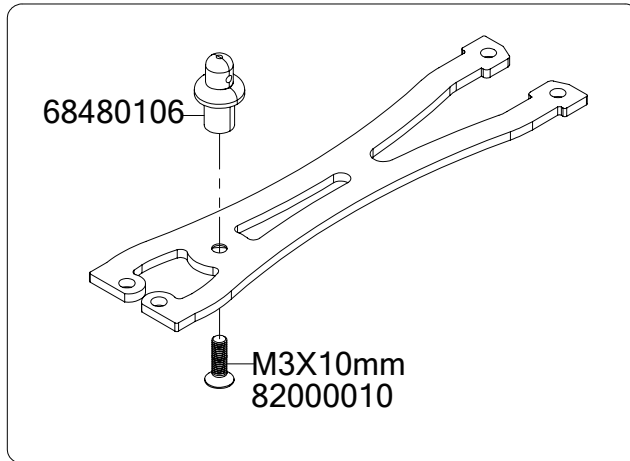

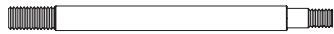

D7 Top Deck Buid

-  ---1
M3X10mm Flat Head Hex Screw
-  ---2
M3X10mm Button Head Hex Screw
-  ---2
M3X12mm Button Head Hex Screw



E1 Shock Assembly

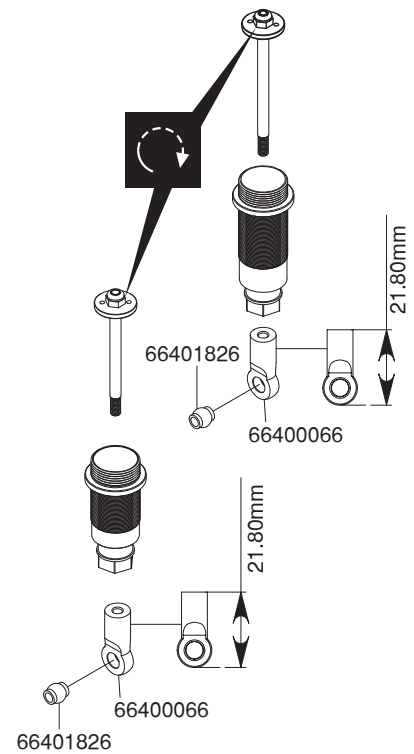
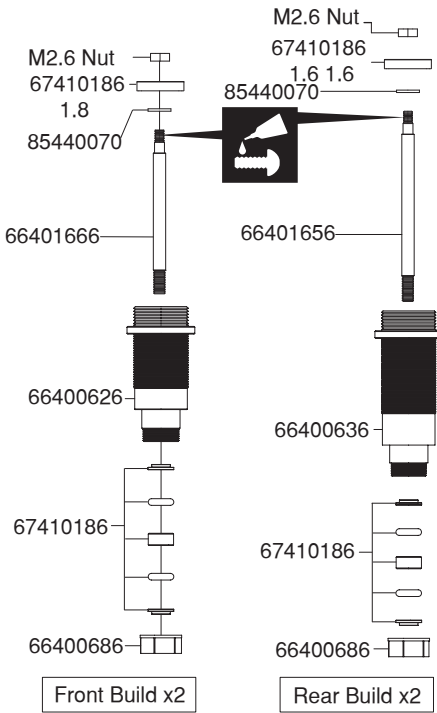

BAG E

-  ----- 2
Front Shock Shaft 66401666
-  ----- 2
Rear Shock Shaft 66401656
-  ----- 8
Threaded Shock Coller
-  ----- 8  ----- 4
Threaded Shock Coller O-Rings (Need to soak silicone oil before)
-  ----- 4  ----- 4
Shock Cartridge Shock Ball---4pcs
-  ----- 2  ----- 2
Shock Piston 1.6 1.6 Shock Piston 1.8



E2 Shock Assembly



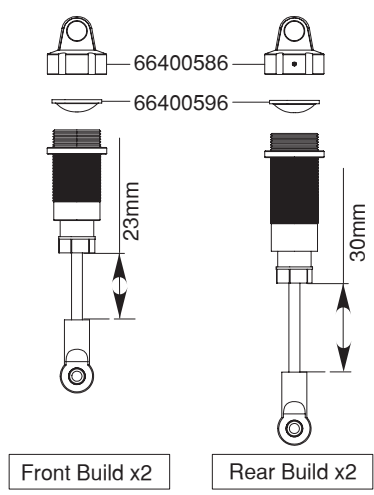
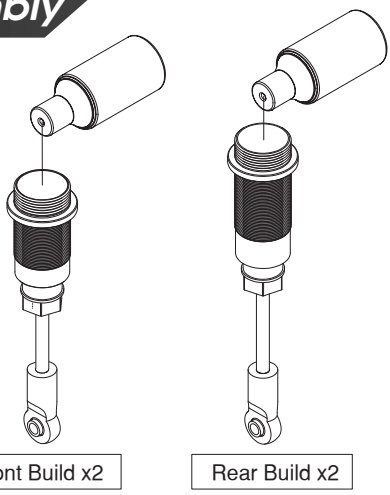

BAG E

-  ----- 4
Shock Bladder Set
-  66401156 300#
Silicone Shock Oil NOT INCLUDED



E3 Shock Spring

BAG E

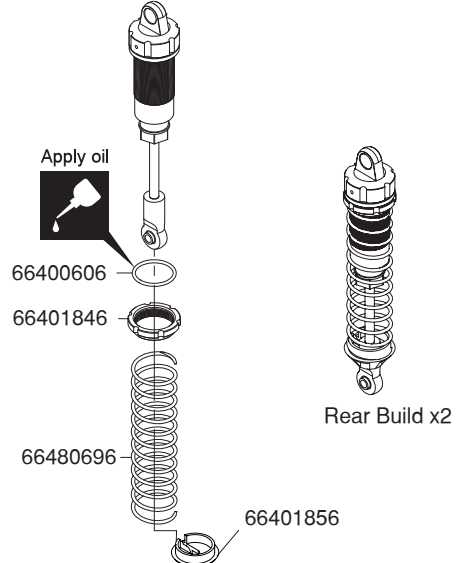
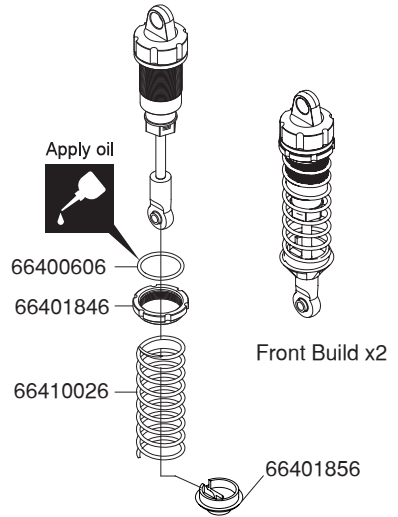

-  ----- 4
Shock Collars O-Rings
-  ----- 2
Front Shock Spring M++
-  ----- 2
Rear Shock Spring M+
-  ----- 4
Shock End & Spring Cup Set & Rod End





E4 Front Suspension



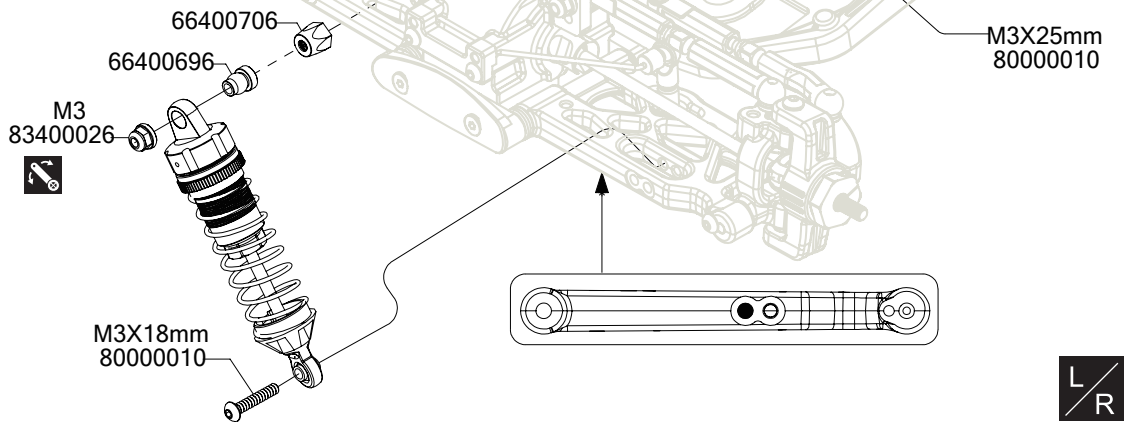
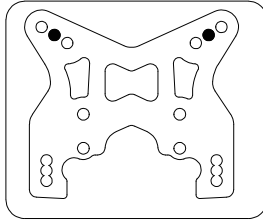

-  --- 2
M3X18mm Button Head Hex Screw
-  --- 2
M3X25mm Button Head Hex Screw
-  --- 2
M3 Lock Nut



E5 Rear Suspension



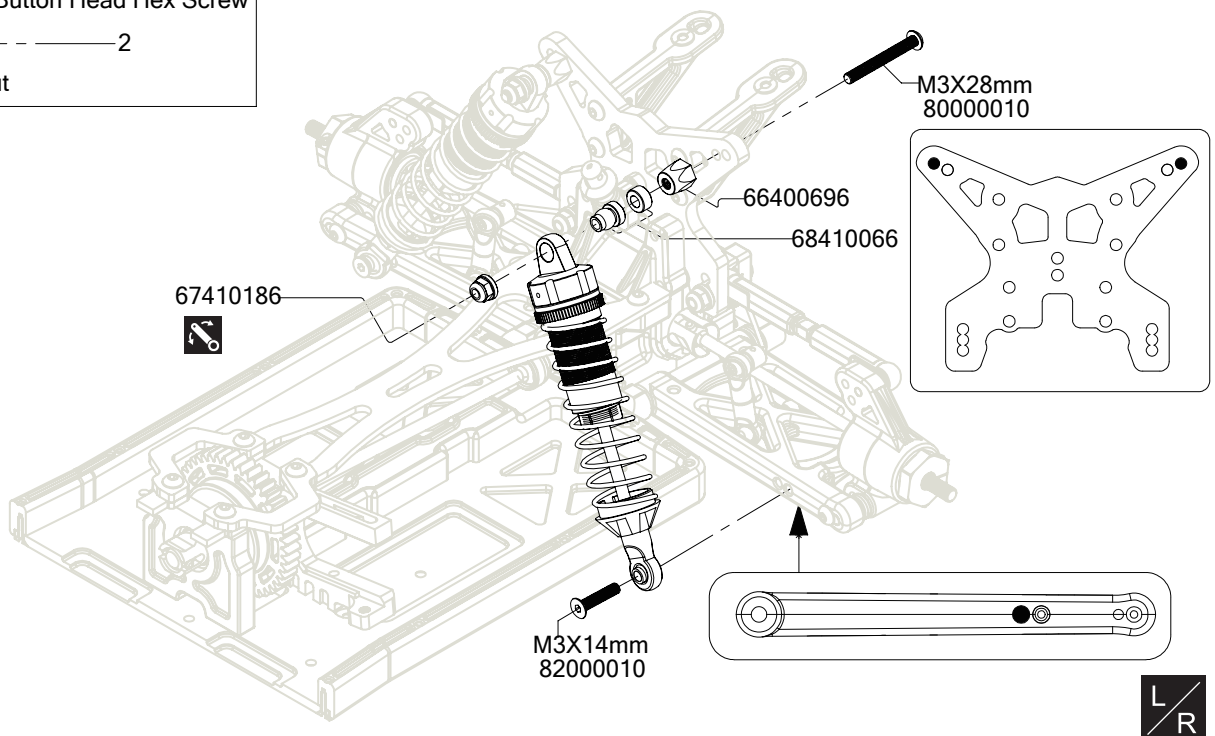

-  --- 2
M3X14mm Flat Head Hex Screw
-  --- 2
M3X28mm Button Head Hex Screw
-  --- 2
M3 Lock Nut





E5 Breech-loading shock combination

-  --- 2
M3X14mm Flat Head Hex Screw
-  --- 2
M3X28mm Button Head Hex Screw
-  --- 2
M3 Lock Nut

因應不同場地,可選擇第二種模式,
將避震器擺在後方。
With different place, you can
choose the second mode,
put the shock behind.

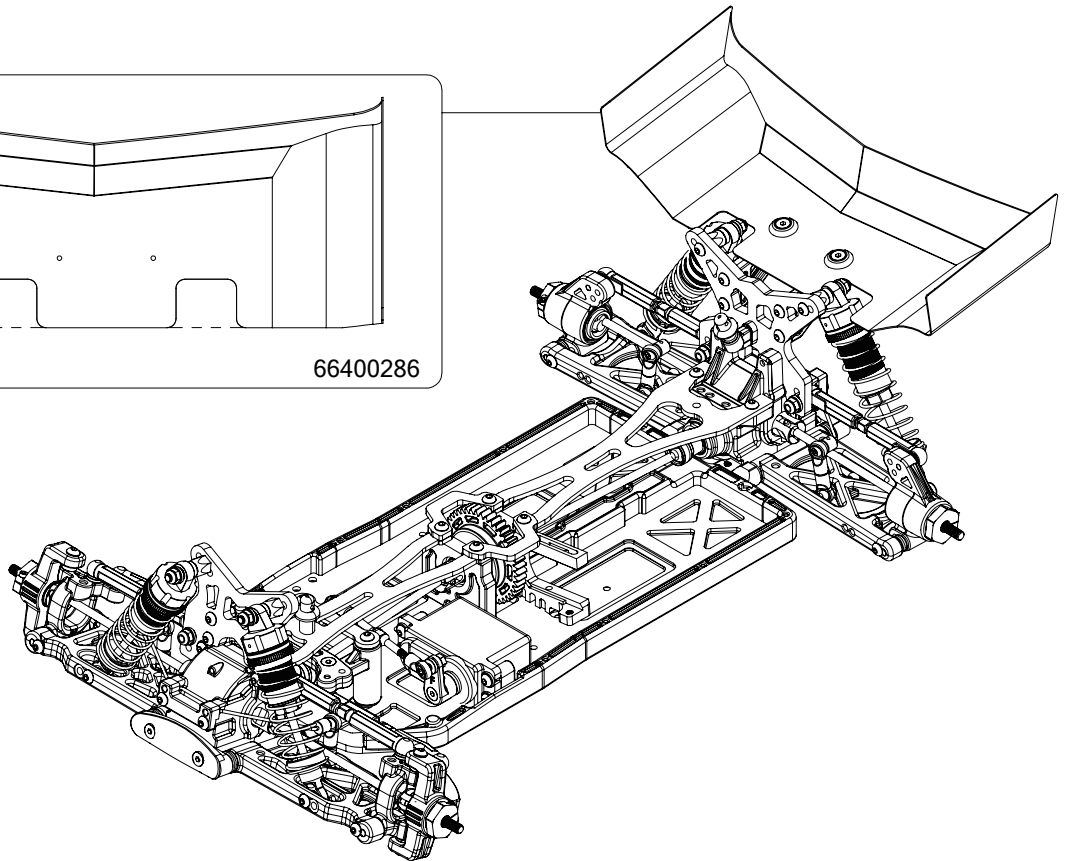
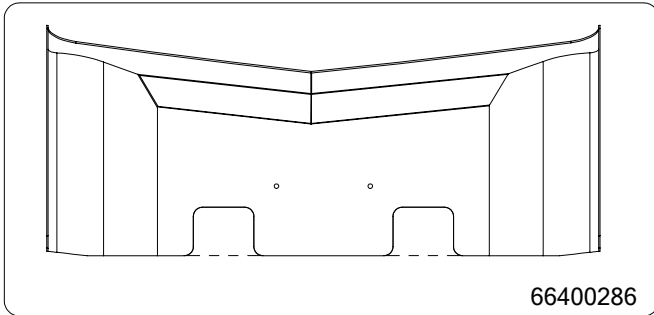
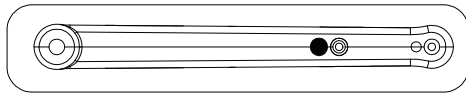
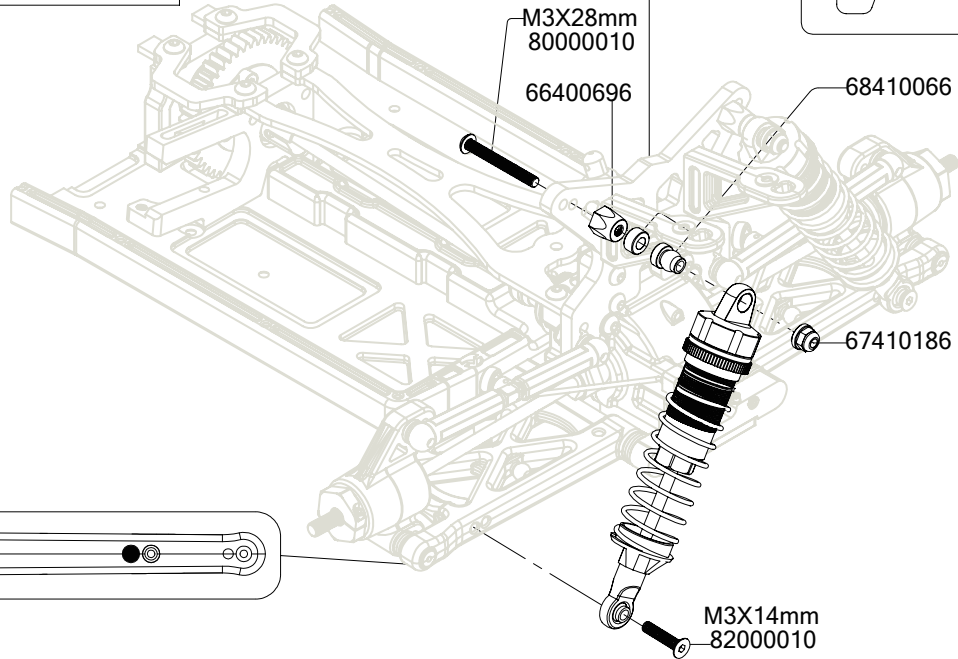
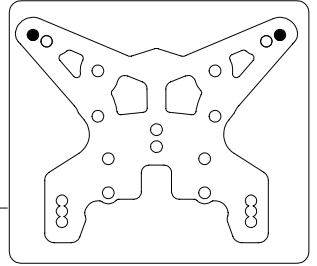

Part Bags used.



Ensure smooth non-binding movement while assembling.



Cut off shaded portion.



Assemble left and right sides the same way.



BAG E

E6 Motor

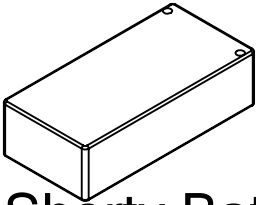

Shorty Battery

- 2
M3X10mm Flat Head Hex Screw
- 1
M3X8mm Button Head Hex Screw
- 2
M3X10mm Flat Head Hex Screw
- M3X10mm 8000010

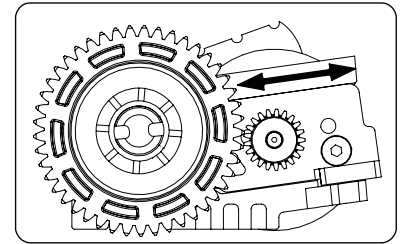

Front

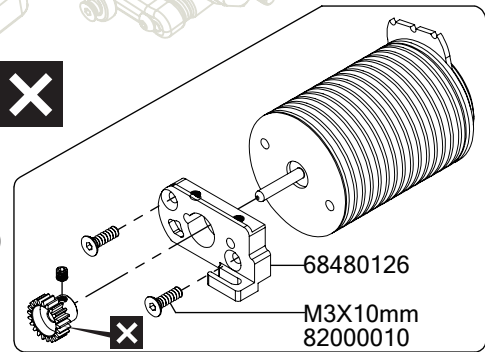

BAG E

E7 Motor

OR

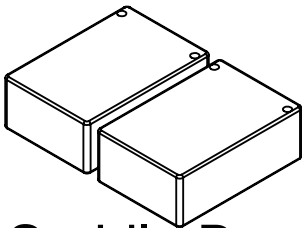

Saddle Battery

- 2
M3X10mm Flat Head Hex Screw
- 1
M3X8mm Button Head Hex Screw
- 2
M3X10mm Flat Head Hex Screw

M3X10mm 8000010

Front

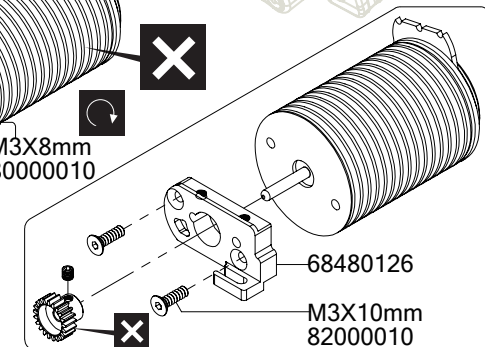
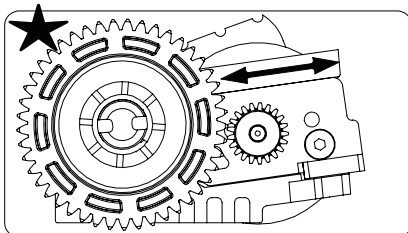



E8 Battery Cradle

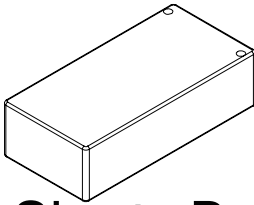

Shorty Battery

- 2
M2.6X6mm Flat Head Hex Screw
- 1
M2.6X16mm Flat Head Hex Screw
- 1
M3X14mm ButtonHead HexScrew
- 1
M3X16mm Set Screw

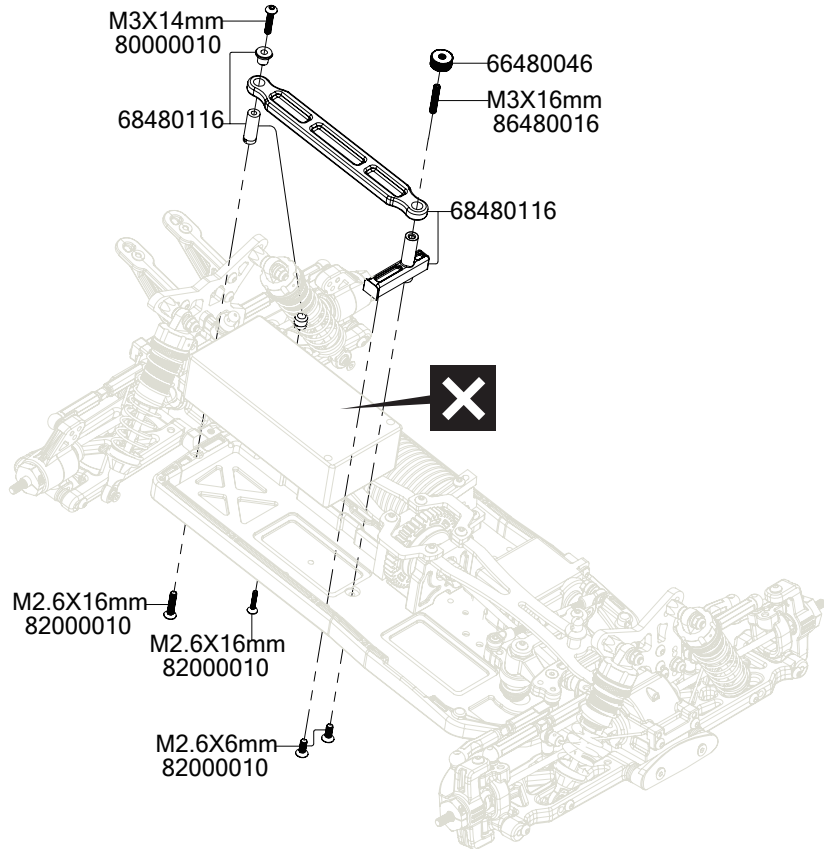

E9 Battery Cradle

OR

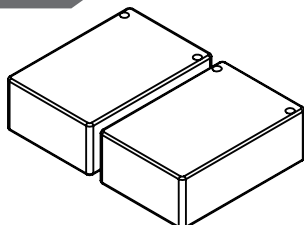

Saddle Battery

- 4
M2.6X6mm Flat Head Hex Screw
- 2
M2.6X16mm Flat Head Hex Screw
- 2
M3X14mm Button Head Hex Screw
- 2
M3X16mm Set Screw

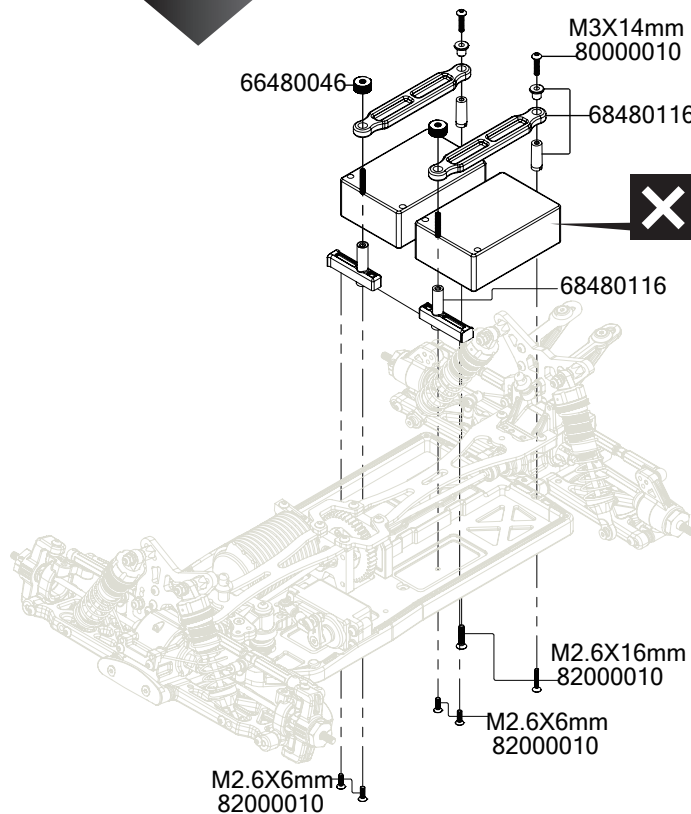

Part Bags used.



Must be purchased separately.



E10 Wheels

--- 2
M3X8mm Flat Head Hex Screw

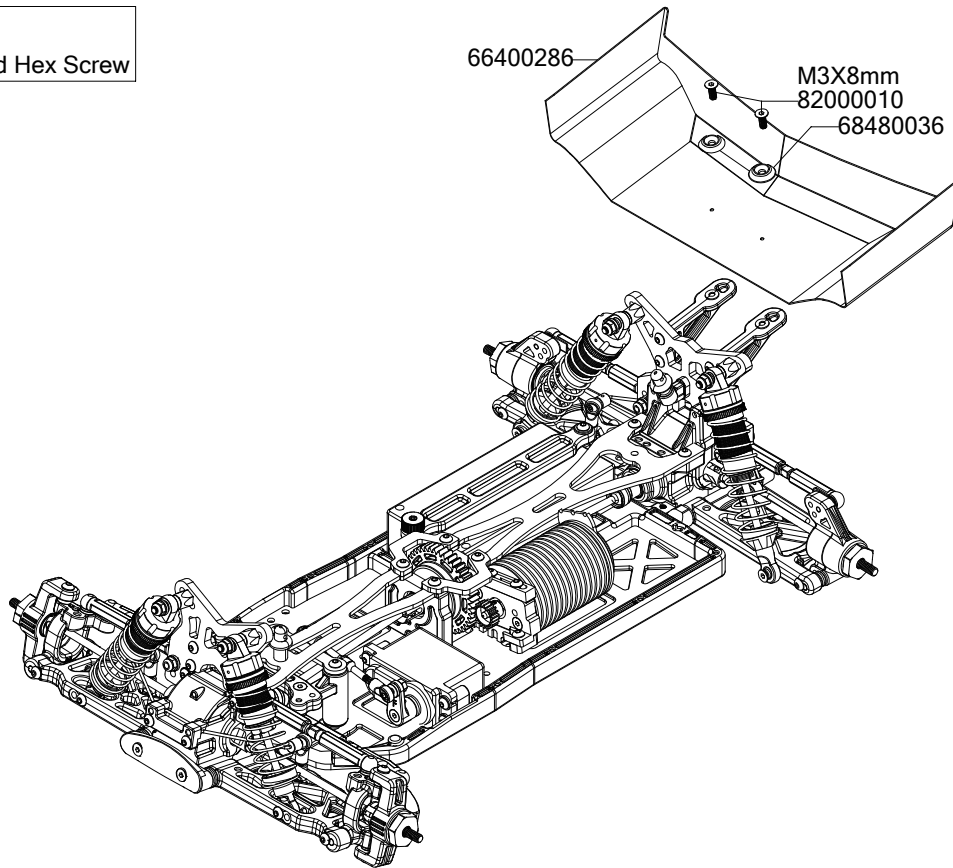

E11 Tires

--- 4
M4 Lock Nut

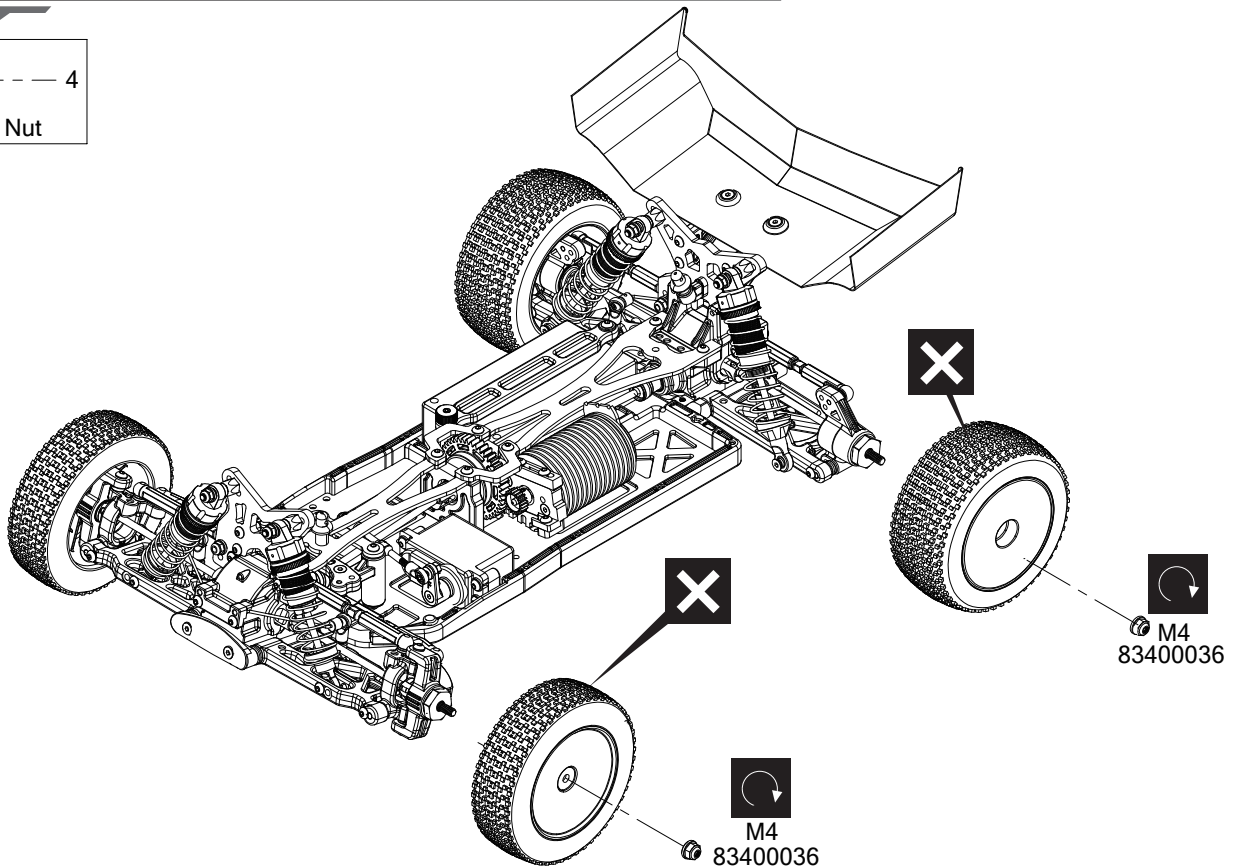



E12 Body Shell



BAG
E

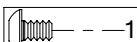

M2.6X4 Button Head Hex Scrw

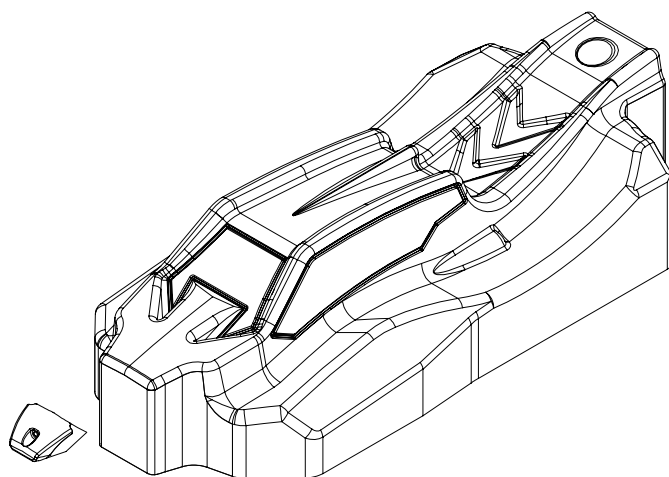

66400946

68000010

66400946

M2.6*4mm
80000010

68000010

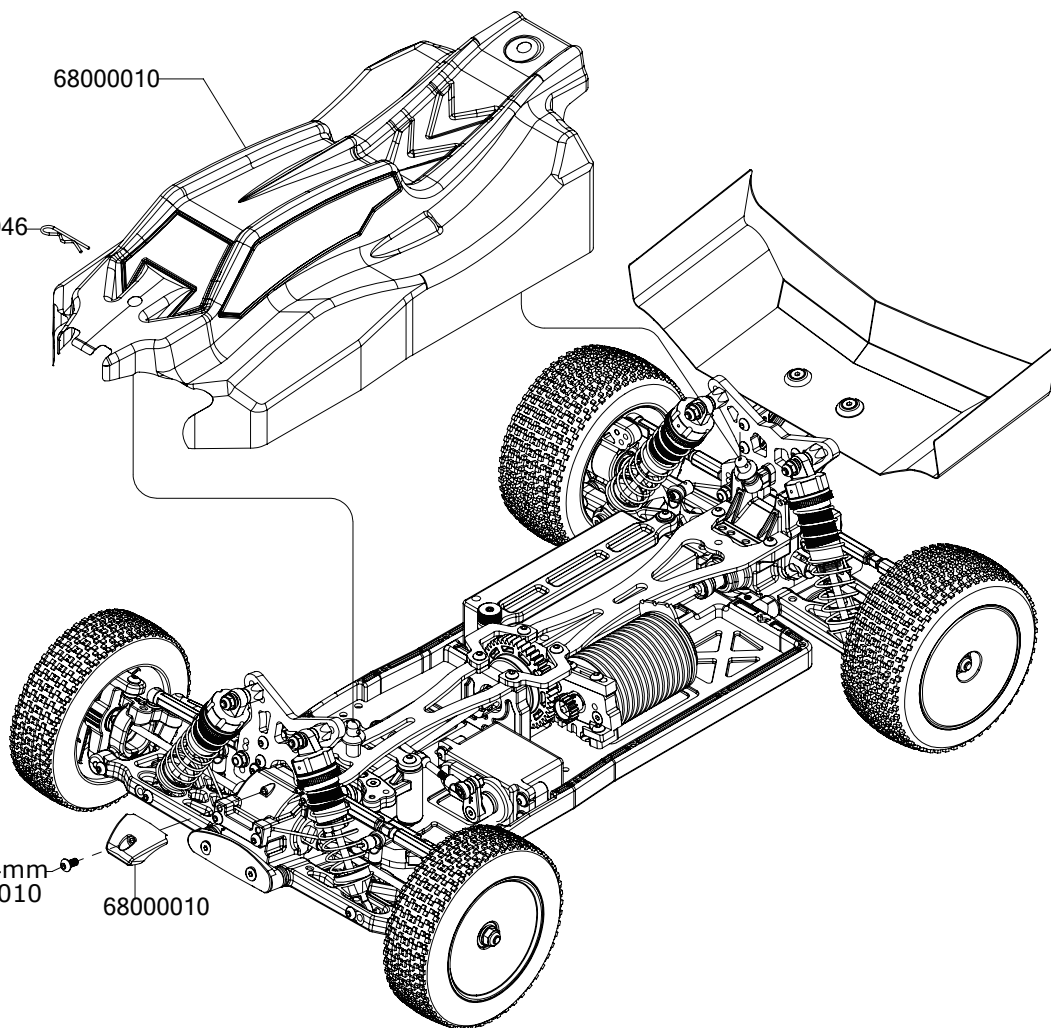

Part Bags used.



Cut off shaded portion.

SETUP SHEET

SETUP SHEET for Name
the PR SB401 姓名

Date 日期

Track/City
跑道/城市

Event 活動

Front Suspension 前

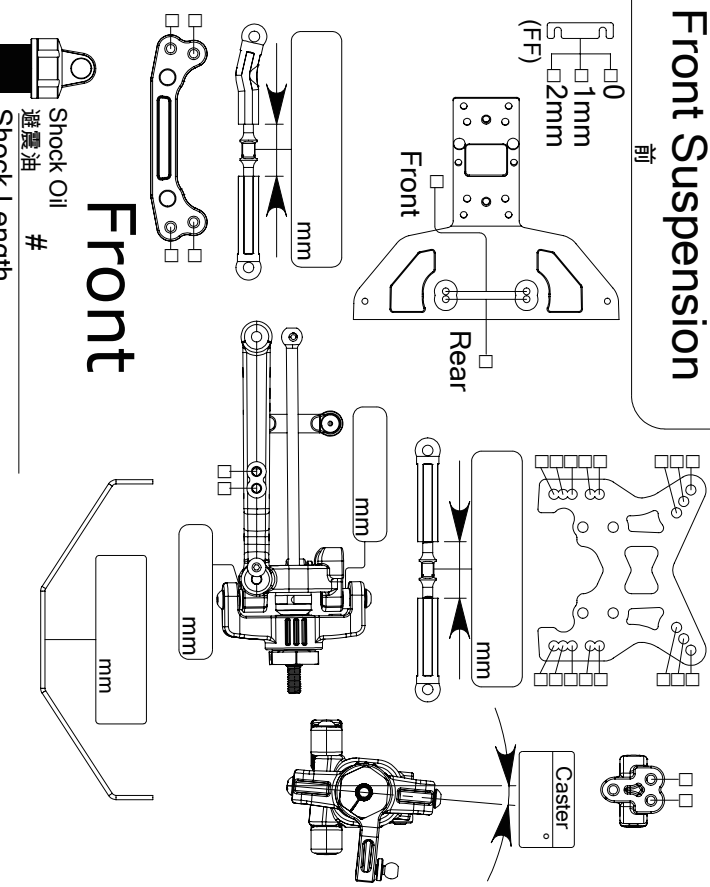

Rear Suspension 後

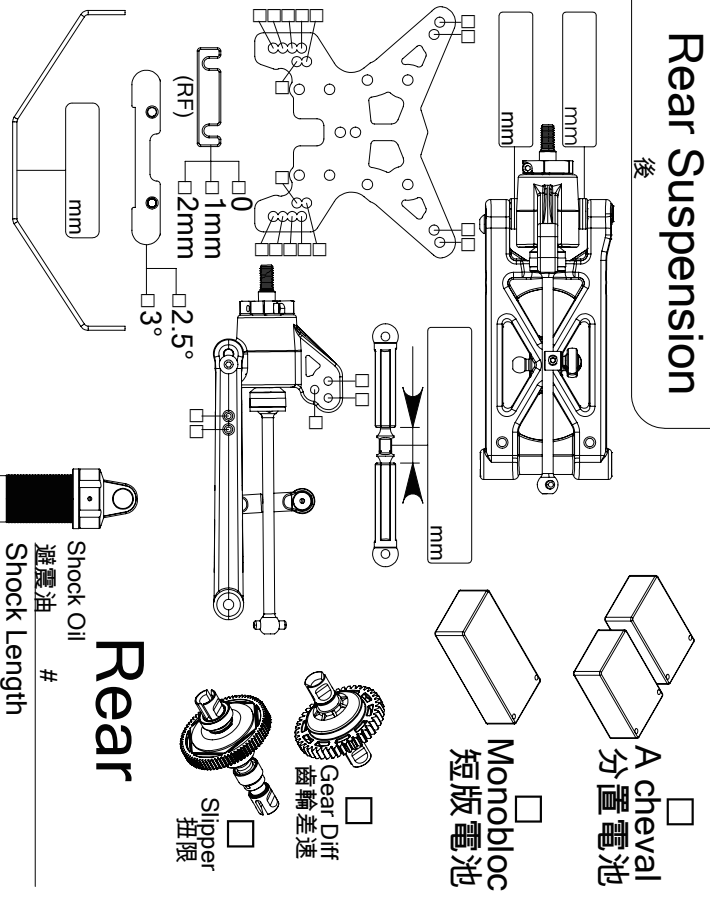

Front

Shock Oil # _____
避震油
Shock Length _____ mm
避震長度
Shock Piston _____ mm
避震活塞
Taper Down _____ mm
向下高度
Spring 彈簧

Rear

Shock Oil # _____
避震油
Shock Length _____ mm
避震長度
Shock Piston _____ mm
避震活塞
Taper Down _____ mm
向下高度
Spring 彈簧

Front Rear

Tire 輪胎
Wheel 輪框
Inlets 內海綿

Diff Oils		
Oil wt	Front	Rear

Weather

氣候 Temperature 溫度
Humidity 溼度

Track Conditions 跑道情況

Size: Open Med Tight
尺寸 開放 中 小
Traction: High Med Low
抓地力 高 中 低
Surface: Smooth Med Bumpy
表面 滑 中 顛坡









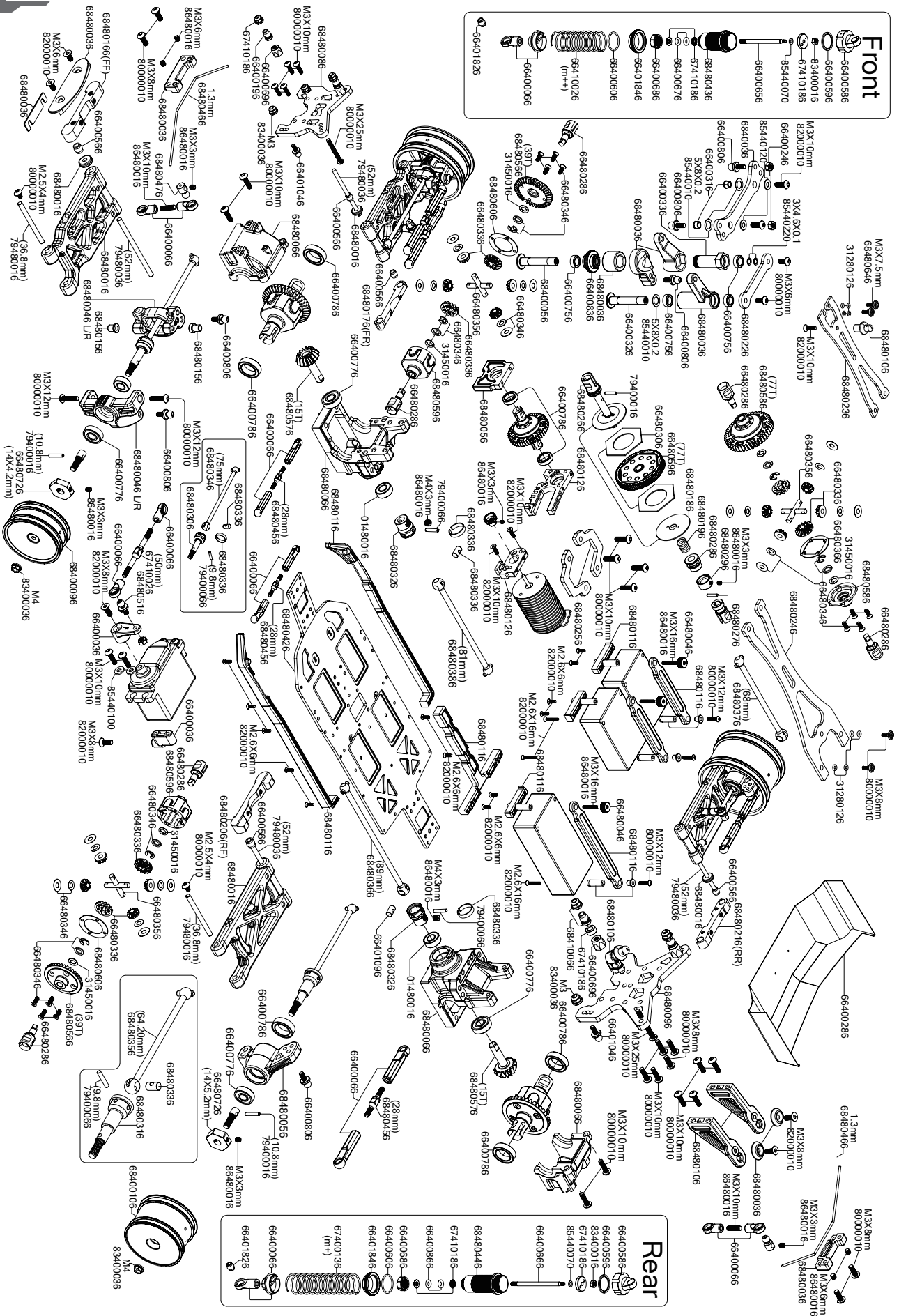

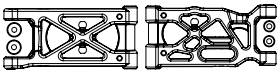

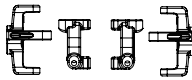
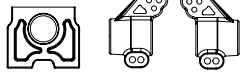
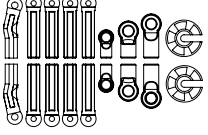
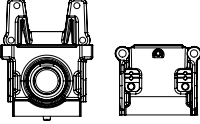
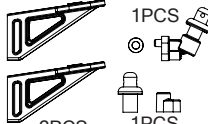
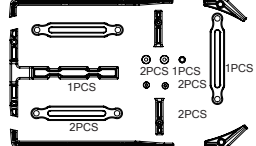
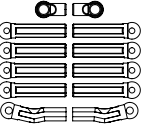
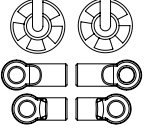
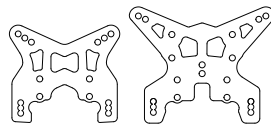
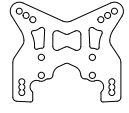
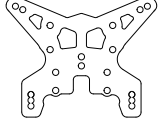
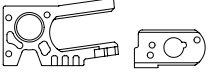

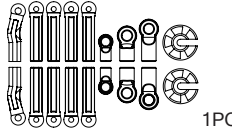
Others 其他



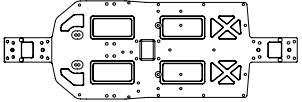
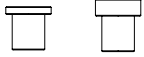
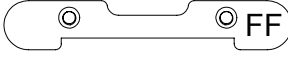
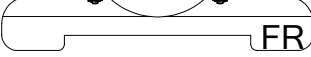
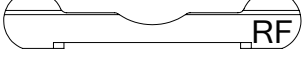
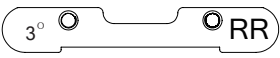
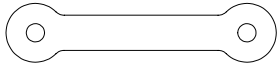

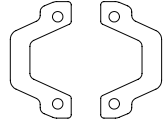
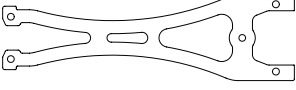
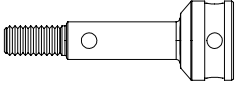



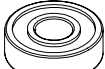
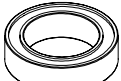



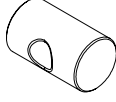

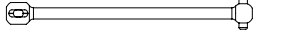
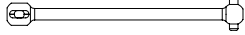
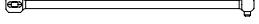

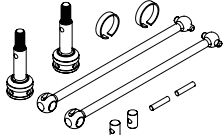
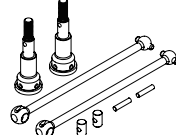
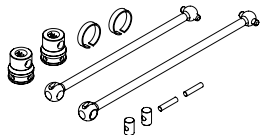
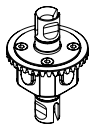
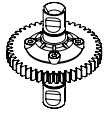
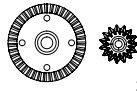
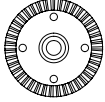
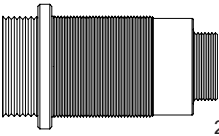
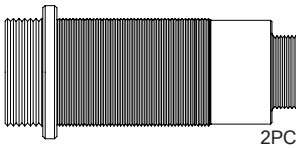
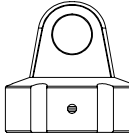
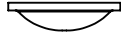

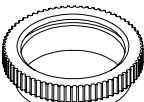

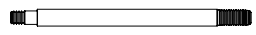
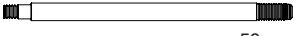



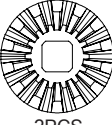
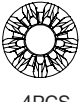

Ride Height 車子高度
ESC/Motor ESC/馬達
Battery 電池
Pinion/Spur 馬達齒/齒輪









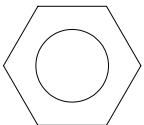





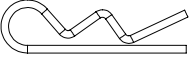
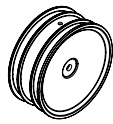
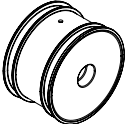

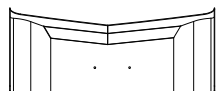



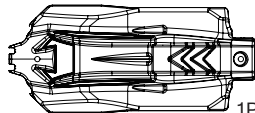

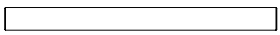
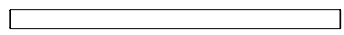

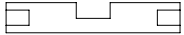
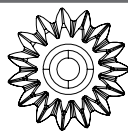
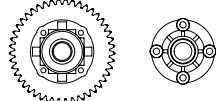
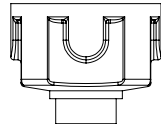
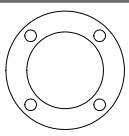
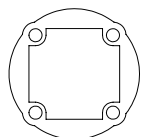
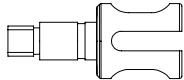
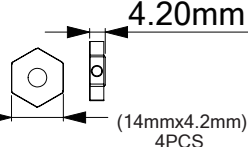
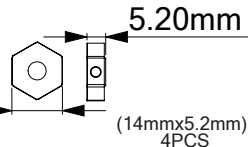
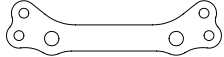
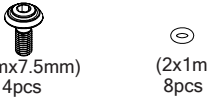



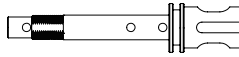
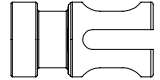

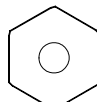
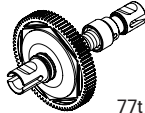
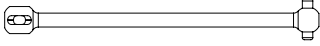
SETUP SHEET

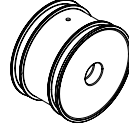



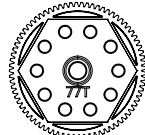

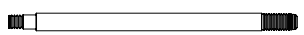
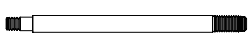
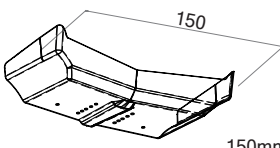

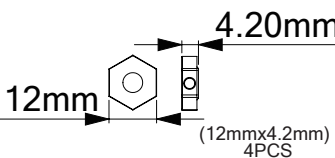
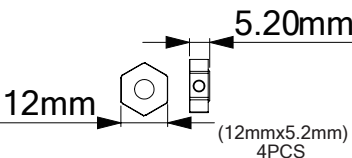
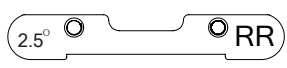







<p>68480016</p>  <p>1PCS</p>	<p>68480036</p>  <p>1PCS 2PCS 2PCS 1PCS 1PCS 3PCS 1PCS 1PCS 2PCS</p>	<p>68480046</p>  <p>1PCS</p>	<p>68480056</p>  <p>1PCS 2PCS</p>
<p>66400066</p>  <p>2PCS</p>	<p>68480066</p>  <p>1PCS</p>	<p>68480106</p>  <p>1PCS 2PCS 1PCS</p>	<p>68480116</p>  <p>1PCS 2PCS 1PCS 2PCS 2PCS</p>
<p>66400176</p>  <p>2PCS</p>	<p>66400186</p>  <p>2PCS</p>	<p>68480076</p>  <p>1PCS</p>	<p>68480086</p>  <p>1PCS</p>
<p>68480096</p>  <p>1PCS</p>	<p>68480126</p>  <p>1PCS</p>	<p>66400316</p>  <p>2PCS</p>	<p>66400956</p>  <p>1PCS</p>
<p>66400326</p>  <p>2PCS</p>	<p>66400336</p>  <p>1PCS</p>	<p>68480456</p>  <p>2PCS 28mm</p>	<p>68480426</p>  <p>1PCS</p>
<p>68480156</p>  <p>2PCS 2PCS</p>	<p>68480166</p>  <p>1PCS</p>	<p>68480176</p>  <p>1PCS</p>	<p>68480206</p>  <p>1PCS</p>
<p>68480216</p>  <p>1PCS</p>	<p>68480226</p>  <p>1PCS</p>	<p>68480236</p>  <p>1PCS</p>	<p>68480256</p>  <p>2PCS</p>
<p>68480246</p>  <p>1PCS</p>	<p>68480306</p>  <p>2PCS</p>	<p>66410026</p>  <p>2PCS M++</p>	<p>66480696</p>  <p>2PCS M+</p>
<p>66400756</p>  <p>5x8x2.5mm Ball Bearing 6PCS</p>	<p>01480016</p>  <p>5x11x4mm Ball Bearing 4PCS</p>	<p>66400776</p>  <p>5x13x4mm Ball Bearing 6PCS</p>	<p>66400786</p>  <p>10x5x4mm Ball Bearing 4PCS</p>

66401086  2PCS	68480326  2PCS	66401096  2PCS	68480336  2PCS
68480346  2PCS 75mm	68480356  2PCS 64.2mm	68480366  1PCS 89mm	68480376  1PCS 68mm
68480386  1PCS 81mm	68480396  SB401 FRONT CVD SET*2PCS	68480406  SB401 REAR CVD SET*2PCS	68480416  SB401 COUPLER CVD SET*2PCS
68480536  SB401 FRONT /REAR DIFF*1PCS	68480546  SB401 CENTER DIFF*1PCS	68480556  1PCS 39t/15t	68480566  1PCS 39t
68480436  2PCS	68480446  2PCS	66400586  4PCS	66400596  4PCS
66400606  4PCS	66401846  4PCS	67410186  2PCS	66401666  2PCS 46mm
66401656  2PCS 53mm	66400676  8PCS	66400866  8PCS	66400686  4PCS
66400696  4PCS	66400706  4PCS	66480336  2PCS  4PCS	66480596  1PCS
83400036  M4 4pcs	67410186  1.6 1.6 2pcs  1.8 2pcs  M3 2PCS  4PCS  2PCS	68410066  4PCS  4PCS	66480306  2PCS

<p>68480466</p>  <p>1PCS 1.3mm</p>	<p>68480476</p>  <p>2PCS</p>	<p>66401046</p>  <p>2PCS 4.8x8mm</p>	<p>66400806</p>  <p>13PCS 4.8x6mm</p>
<p>66400836</p>  <p>1PCS</p>	<p>66400946</p>  <p>2PCS</p>	<p>68400096</p>  <p>White 14mm 2PCS</p>	<p>68400106</p>  <p>White 14mm 2PCS</p>
<p>67410026</p>  <p>2PCS 50mm</p>	<p>68480496</p>  <p>8PCS</p>	<p>66400286</p>  <p>1.2mm</p>	<p>68400116</p>  <p>#300 1PCS</p>
<p>66401216</p>  <p>SB401 FRONT SUSPENSION SET*2PCS</p>	<p>66401226</p>  <p>SB401 REAR SUSPENSION SET*2PCS</p>	<p>68000010</p>  <p>1PCS</p>	<p>31450016</p>  <p>4PCS</p>
<p>79480016</p>  <p>4PCS 3x36.8mm</p>	<p>79480036</p>  <p>4PCS 3x52mm</p>	<p>79400066</p>  <p>2PCS 2x9.9 mm</p>	<p>66480356</p>  <p>2PCS</p>
<p>68480576</p>  <p>1PCS 15t</p>	<p>68480586</p>  <p>1PCS</p>	<p>68480596</p>  <p>2PCS</p>	<p>66480356</p>  <p>2PCS</p>
<p>66480366</p>  <p>2PCS</p>	<p>66480286</p>  <p>2PCS</p>	<p>80000010</p> <p>M2.6x4mm 5pcs M3x6mm 2pcs M3x8mm 16pcs M3x10mm 20pcs M3x12mm 6pcs M3x14mm 2pcs M3x18mm 2pcs M3x25mm 2pcs M3x28mm 2pcs</p>	<p>82000010</p> <p>M2.6x6mm 19pcs M2.6x16mm 6pcs M3x6mm 12pcs M3x8mm 11pcs M3x10mm 5pcs M3x14mm 6pcs</p>
<p>86480016</p> <p>M3x3mm 8pcs M3x6mm 8pcs M3x10mm 4pcs M3x16mm 2pcs M4x3mm 2pcs</p>	<p>66480726</p>  <p>4.20mm 14mm (14mmx4.2mm) 4PCS</p>	<p>68440020</p>  <p>5.20mm 14mm (14mmx5.2mm) 4PCS</p>	<p>68400036</p>  <p>1PCS</p>
<p>68480646</p>  <p>(3mmx7.5mm) 4pcs (2x1mm) 8pcs</p>			

68480186  2PCS	68480196  1PCS	68480266  1PCS	68480276  1PCS
68480286  1PCS	68480296  1PCS	68000020  4pcs 12mmx4mm	68400086  1PCS 77t
68410026  68mm	68400066  White 12mm 2PCS	68400076  White 12mm 2PCS	68000030  1PCS carbon
66480576  73t	66480586  76t	66480596  77t	68480526  1.6mm
66480636  2PCS Ti 53mm	66480626  2PCS Ti 46mm	66401626  150mm	68480486  1PCS 1.4mm
68000040  12mm 4.20mm (12mmx4.2mm) 4PCS	68440010  12mm 5.20mm (12mmx5.2mm) 4PCS	68480636  2.5° RR 1PCS	

DESCRIPTION		PR 2014 S1v2 2WD	PR S1M 2WD	PR SB401 4WD
Front ALUMINUM Hexagonal Wheel Stand (12mmx3.2mm) 66480726		√	√	
Front ALUMINUM Hexagonal Wheel Stand (12mmx4.2mm) 68000040				√
Front ALUMINUM Hexagonal Wheel Stand (14mmx4.2mm) 68400046				√
Rear ALUMINUM Hexagonal Wheel Stand (12mmx4.0mm) 66480216		√	√	
Rear ALUMINUM Hexagonal Wheel Stand (12mmx4.2mm) 68000040				√
Rear ALUMINUM Hexagonal Wheel Stand (14mmx4.2mm) 68400046				√
Rear ALUMINUM Hexagonal Wheel Stand (12mmx5.2mm) 68440010				√
Rear ALUMINUM Hexagonal Wheel Stand (14mmx5.2mm) 68440020				√
2WD 1/10 Buggy Wheel Front (12mm) 66400966		√	√	
4WD 1/10 Buggy Wheel Front (12mm) 68400066				√
4WD 1/10 Buggy Wheel Front (14mm) 68400096				√
2WD 1/10 Buggy Wheel Rear (12mm) 66400976		√	√	√
4WD 1/10 Buggy Wheel Rear (12mm) 68400076		√	√	√
4WD 1/10 Buggy Wheel Rear (14mm) 68400106				√

PR Racing SB401 1/10 Electric 4WD Off Road Buggy Specifications

- Motor: Electric
- Wheelbase: 284mm
- 12 degree chassis Kick up (Adjustment range:20 degree)
- All Metric Hardware
- Full Precision Ball Bearings completion option in the same kit
- Same Front and Rear Wheels (14mm Hex)(12mm Hex)
- 77 tooth(differential) spur gear
- Drivetrain: 4wd
- Motor or Engine: Accepts 540 size
- New motor mount can change motor position easily (front or rear)
- Tooth Gear Pitch: 48 Pitch
- Kit/RTR: Kit
- Shock Type: Oil Filled Aluminum Shocks
- with bladders
- Body: Unpainted clear body with over spray
- CNC aluminum one-piece motor mount
- CVD bones x6
- Width:248mm
- Weight:1785g(weight varies with choice of electronics, tires & body)
- Length:284mm
- Gear Ratio:2.6:1
- 7.4V/4000-6000mAh approx
- Minimum Age Recommendation : 14 years

Items required to complete

- Metric 1.5mm, 2.0mm hex tools
- Metric 5.5mm, 7.0mm Nut Driver
- 2 Channel Surface Radio System (Minimum)
- 1/10 ESC, Motor & Pinion Gear
- High Speed Servo
- 2S LiPo Battery & Compatible Lipo Charger
- Polycarbonate Paint for Bodies
- 1/10 Truck Tires, inserts and CA Glu
- Silicon diff oil
- LOK threadlocker

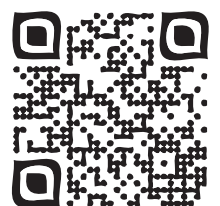

PR SB401

1/10 ELECTRIC 4WD OFF ROAD BUGGY

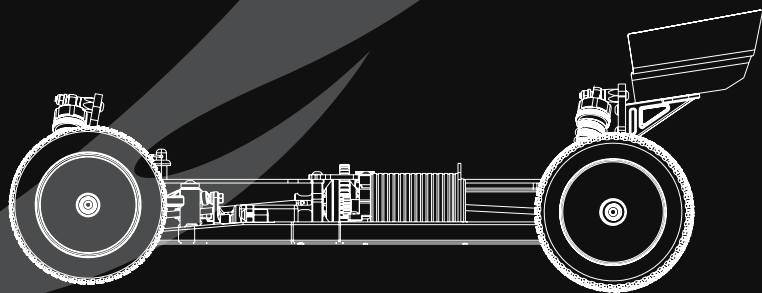

EMAIL / info@prengine.com.tw
10F., No.68, Zhongzheng Rd. Xinzhuang Dist.,
New Taipei City 24243, Taiwan (R.O.C.)