

### FRONT SUSPENSION

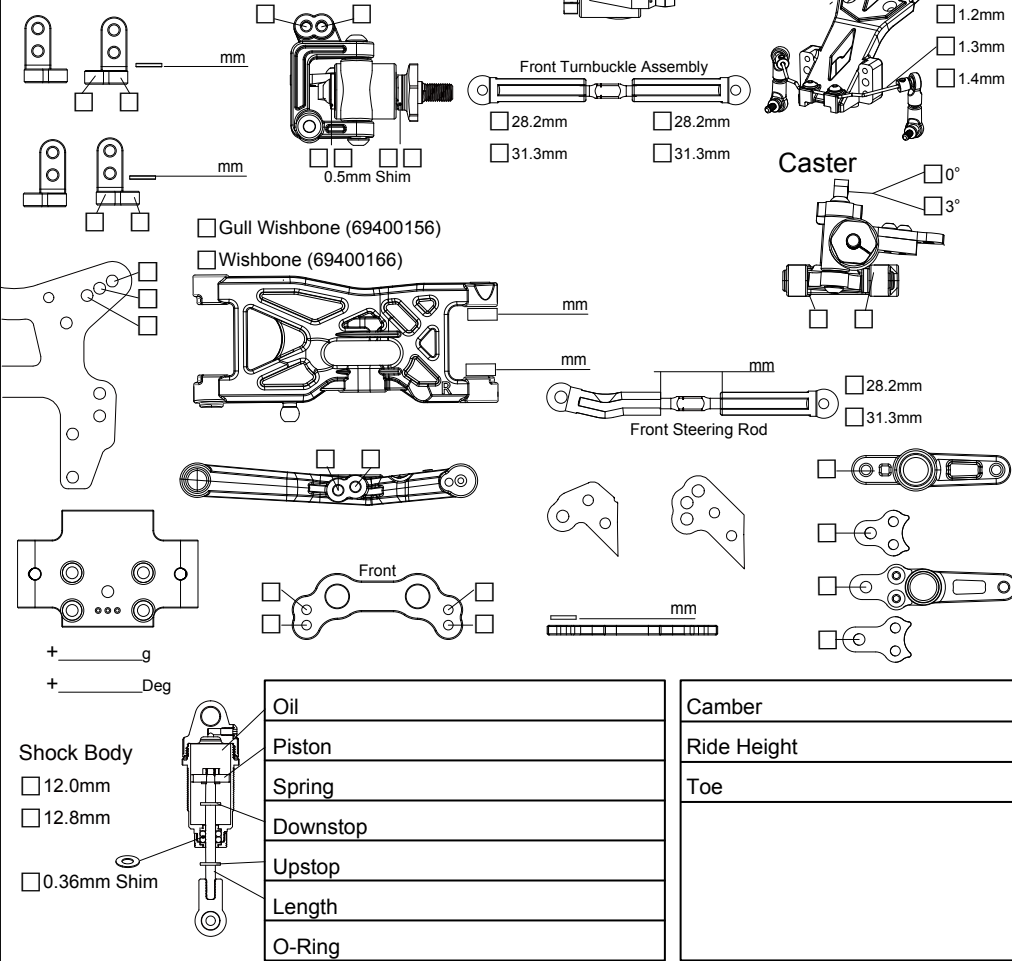

### REAR SUSPENSION

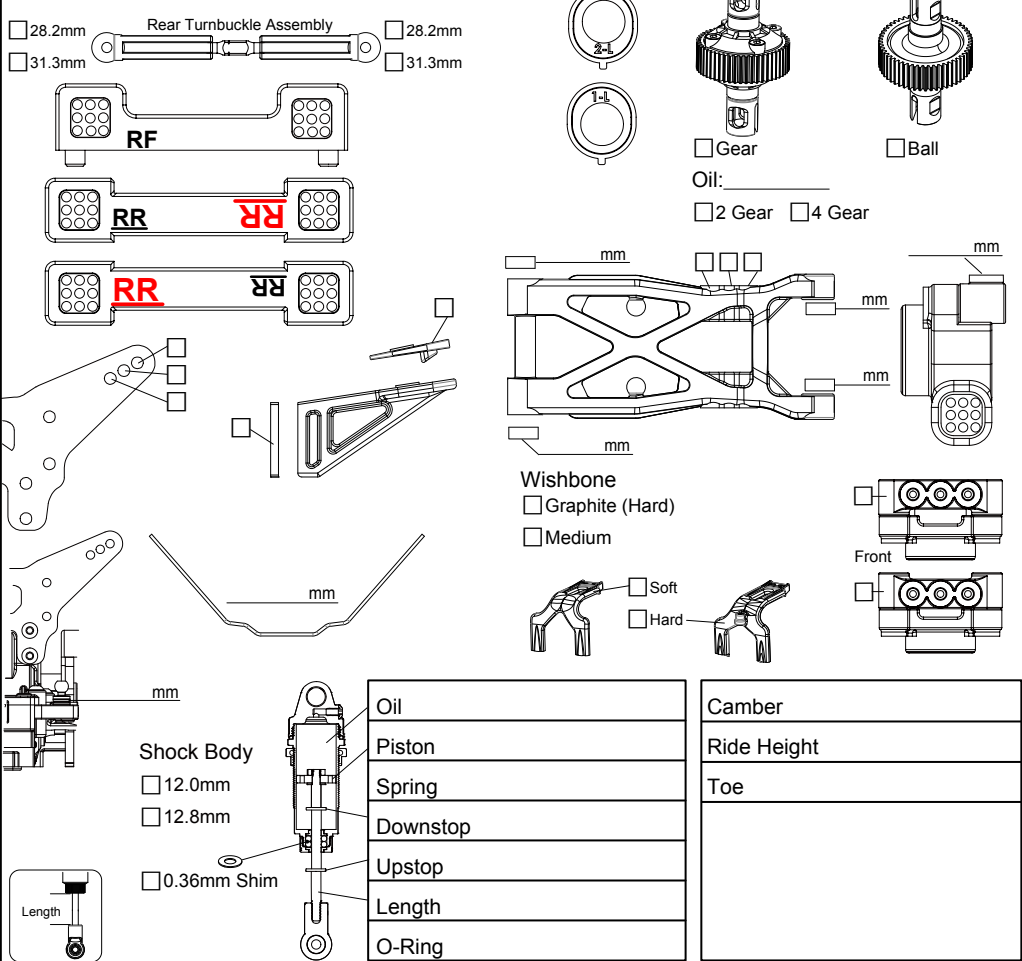

### FRONT

Motor	Pinion
Spur	ESC
Servo	Profile: <input type="checkbox"/> Std. <input type="checkbox"/> Low
Battery	Size: <input type="checkbox"/> Std. <input type="checkbox"/> Low

### TRACK CONDITIONS

Layout	<input type="checkbox"/> Open	<input type="checkbox"/> Mixed	<input type="checkbox"/> Tight
Traction	<input type="checkbox"/> Low	<input type="checkbox"/> Medium	<input type="checkbox"/> High
Surface	<input type="checkbox"/> Bumpy	<input type="checkbox"/> Smooth	
Composition	<input type="checkbox"/> Astroturf	<input type="checkbox"/> Carpet	<input type="checkbox"/> Clay
	<input type="checkbox"/> Dirt	<input type="checkbox"/> Grass	
Condition	<input type="checkbox"/> Blue Groove	<input type="checkbox"/> Hard Packed	<input type="checkbox"/> Loamy
	<input type="checkbox"/> Dusty	<input type="checkbox"/> Dry	<input type="checkbox"/> Wet

### AERODYNAMICS

Body
Wing
Front Wing
<b>WEIGHT</b>
Under Servo
Under ESC
Under Battery

### WEIGHT DISTRIBUTION

