

S1v3 FM Name / 姓名 Mike waugh
 MM

Date / 日期 23/04/17

Track/City / 跑道/城市 Nora

Event / 活動 SORC round 1

Front Suspension

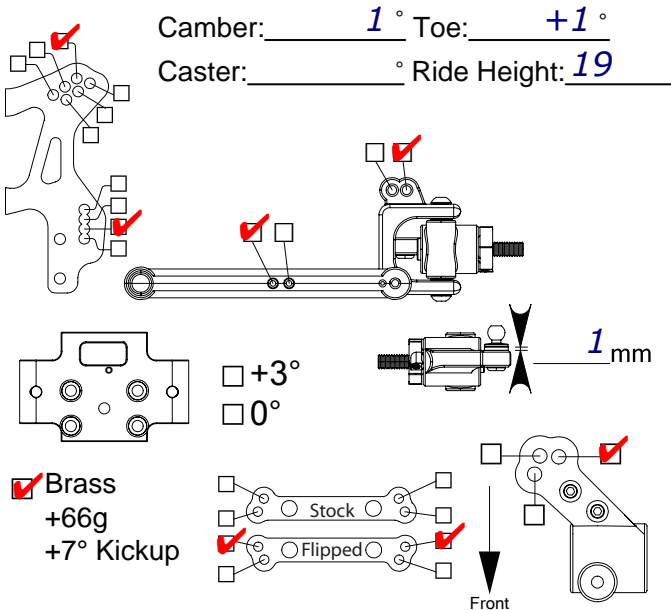

Rear Suspension

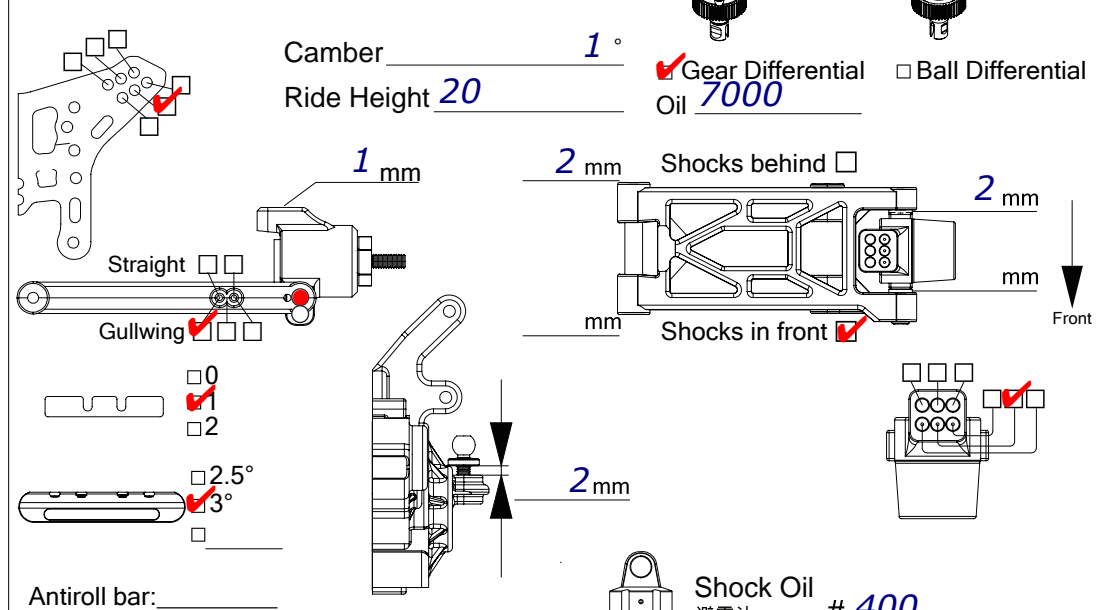

Shock Oil 避震油 # 450
 Shock Piston 避震活塞 1.6 2hole
 Spring 彈簧 Orange AE
 Preload 向下高度 _____ mm
 Limiters 2.5 mm
 Inside _____ mm
 Outside _____ mm

+5+7 degree front bulkhead
Long rod ends on shocks all round
New camber links on front with 1mm spacer under ball stud and on outer hole
Battery in middle
15g under gear box
100g under lipo
***for next time on grass going to put 1.6 3hole pistons in rear*

Tires & Wheels

Front
 Tire 輪胎 Yellow cut staggers
 Wheel 輪框 PR Slim
 Insets 內海綿 None
 Notes

Rear
 Tire 輪胎 Yellow mini spikes
 Wheel 輪框 PR
 Insets 內海綿 Schumacher medium blue
 Notes

Weather

Temperature / 溫度 10
 Humidity / 溼度 _____

Track Conditions

Size: Open 開放 Med 中 Tight 小
 Traction: High 高 Med 中 Low 低
 Surface: Smooth 滑 Med 中 Bumpy 顛坡
 Composition: Astroturf Carpet
 Clay Dirt Grass Wood
 Other: _____

Others

ESC Maclan
 Motor 馬達 Maclean 6.5
 Battery 電池 Orion 4500
 Pinion/Spur 馬達齒/齒輪 Kit/24
 Wing Xray 1.5mm