

Front Suspension

Camber _____ deg

Toe _____ deg

Caster _____ deg

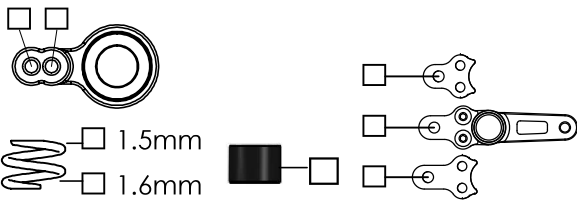
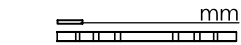
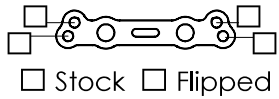
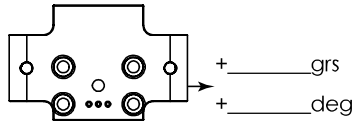
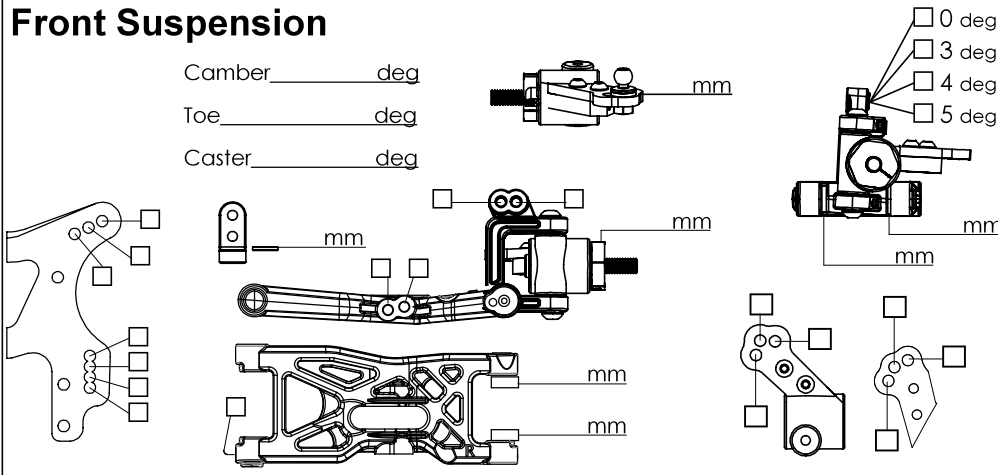

Shock Oil
避震油
Shock Piston
避震活塞
Spring
彈簧
Preload
向下高度 _____ mm
Limiters
Inside _____ mm
Outside _____ mm

Notes

Rear Suspension

Camber _____ deg

Gear Differential Ball Differential

Oil _____

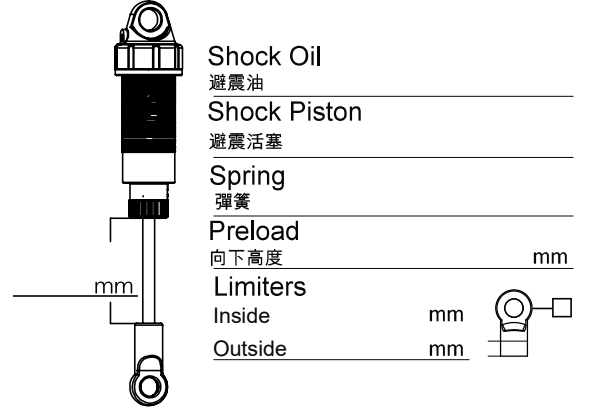
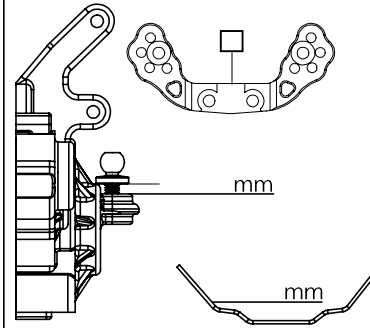
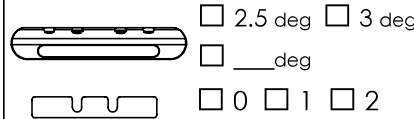
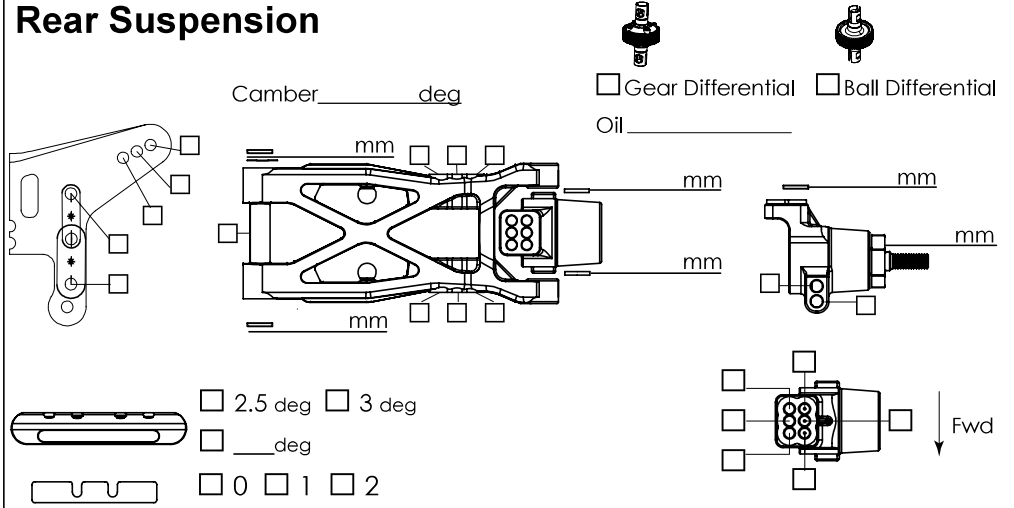

Shock Oil
避震油
Shock Piston
避震活塞
Spring
彈簧
Preload
向下高度 _____ mm
Limiters
Inside _____ mm
Outside _____ mm

Notes

Tires & Wheels

Front

Tire 輪胎 _____

Wheel 輪框 _____

Insets 內海綿 _____

Rear

Tire 輪胎 _____

Wheel 輪框 _____

Insets 內海綿 _____

Notes

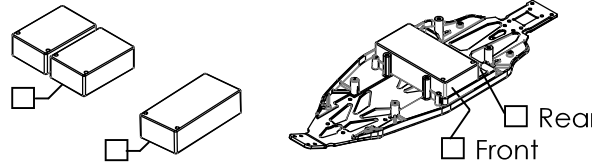

Temp

Track Conditions/跑道情況

Composition: Astro Carpet Clay Dirt Grass

Layout/尺寸: Open/開放 Mixed/中 Tight/小

Traction/抓地力: Low/低 Medium/中 High/高

Surface/表面: Smooth/滑 Bumpy/顛坡

Humidity

Others

ESC _____

Motor 馬達 _____

Battery 電池 _____

Pinion/Spur 馬達齒/齒輪 _____

Wing _____