

Driver : \_\_\_\_\_  
 Date : \_\_\_\_\_  
 Track : \_\_\_\_\_  
 Event : \_\_\_\_\_

Track Condition  
 Size : Open  Mid  Tight   
 Traction : High  Mid  Low   
 Condition : Smooth  Bumpy  Dry  Wet   
 Surface : Carpet  Dirt  AstroTurf

## Front Suspension

Ride Height : \_\_\_\_\_  
 Camber : \_\_\_\_\_  
 Toe : \_\_\_\_\_  
 Anti-roll Bar : \_\_\_\_\_  
 Front Bulkhead Spacer : \_\_\_\_\_  
 Plastic mm / Brass mm  
 Notes : \_\_\_\_\_

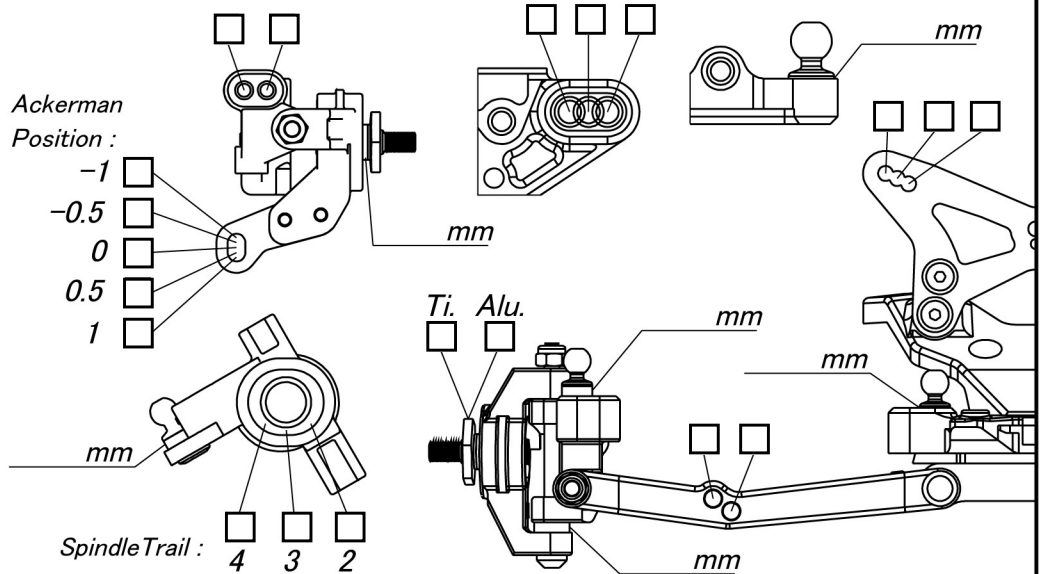

## Rear Suspension

Ride Height : \_\_\_\_\_  
 Camber : \_\_\_\_\_  
 Anti-roll Bar : \_\_\_\_\_  
 Arm Position : Fwd  Back   
 Hub Position : Fwd  Mid  Back   
 Notes : \_\_\_\_\_

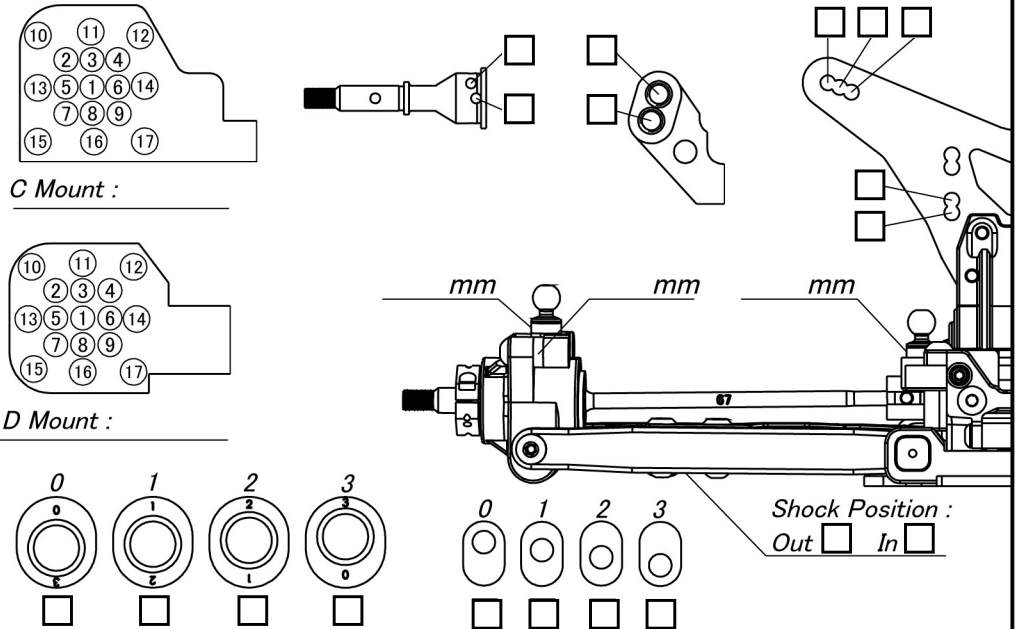

## Shocks

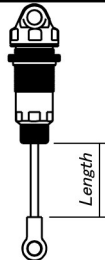

	Front		Rear			
Piston :						
Oil :						
Spring :						
Length :						
Limiters :	Int :	Ext :	Int :	Ext :		
Eyelet Length :	Std <input type="checkbox"/>	+2 <input type="checkbox"/>	Std <input type="checkbox"/>	+2 <input type="checkbox"/>		
Cup Offset :	Low <input type="checkbox"/>	Mid <input type="checkbox"/>	High <input type="checkbox"/>	Low <input type="checkbox"/>	Mid <input type="checkbox"/>	High <input type="checkbox"/>

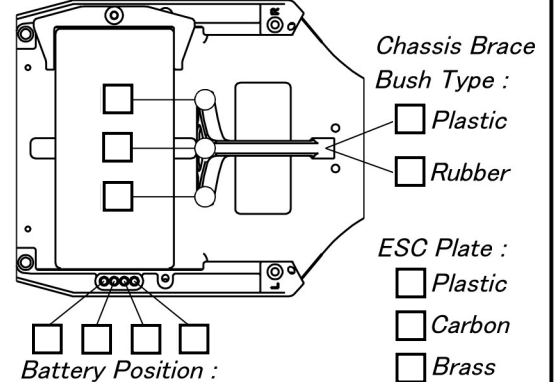

## Electronics

Radio : \_\_\_\_\_  
 Servo : \_\_\_\_\_  
 ESC : \_\_\_\_\_  
 Motor : \_\_\_\_\_  
 Gearing : / \_\_\_\_\_  
 Battery : / \_\_\_\_\_ g

Weight  
 Servo Weight : Yes  No   
 Battery Weight : 19g  37g

## Differential

Gear Diff  2 Gear  Oil : \_\_\_\_\_  
 4 Gear  Friction O-ring : \_\_\_\_\_  
 Ball Diff  Setting : \_\_\_\_\_

Tire  
 Front \_\_\_\_\_ Rear \_\_\_\_\_  
 Type : \_\_\_\_\_  
 Compound : \_\_\_\_\_  
 Inserts : \_\_\_\_\_  
 Wheel : \_\_\_\_\_  
 Additive : \_\_\_\_\_

Total Weight : \_\_\_\_\_ g

## Body & Wing

Body : \_\_\_\_\_  
 Rear Wing : \_\_\_\_\_  
 Wing Angle : 0°  3°  6°   
 Front Wing : \_\_\_\_\_ Low :  High :